

FÅGELFJÄLLET

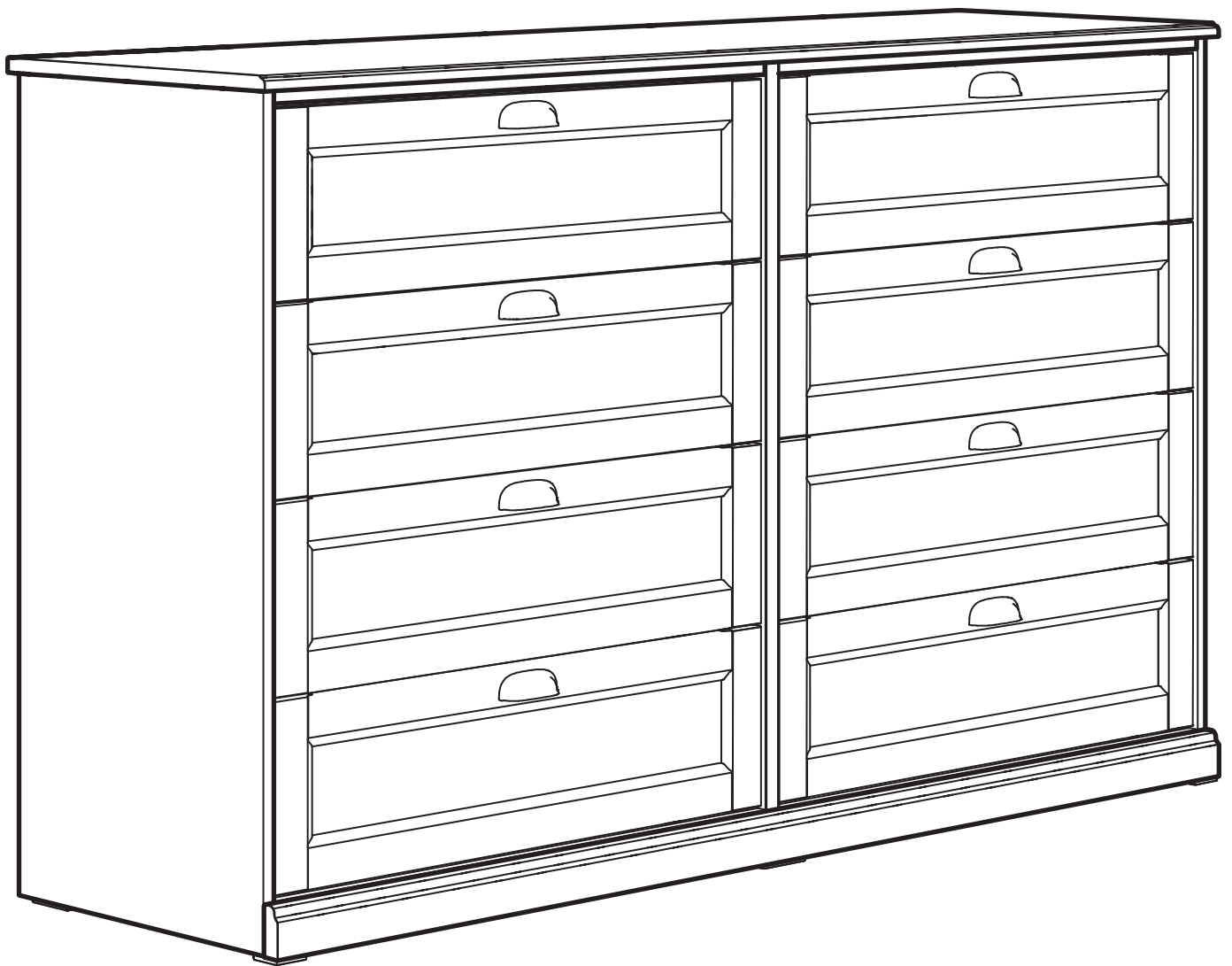

Design and Quality
IKEA of Sweden

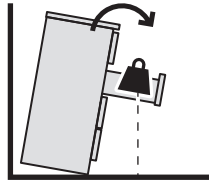
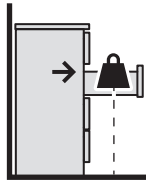

English

WARNING!

Children have died from furniture tipover.

To reduce the risk of furniture tipover:

- ALWAYS install anti-tip device provided.
- NEVER put a TV on this product.
- NEVER allow children to stand, climb, or hang on any drawers, doors, or shelves.
- NEVER open more than one drawer at a time.
- DO NOT defeat or remove the drawer interlock system; it is an important stability and safety system.
- Place heaviest items in the lowest drawers.
- Read and follow each step of the instruction carefully.

Français

AVERTISSEMENT !

Des enfants sont morts suite au basculement d'un meuble.

Afin de limiter le risque de basculement d'un meuble :

- TOUJOURS utiliser le système anti-basculement fourni.
- NE JAMAIS installer de TV sur ce produit.
- NE JAMAIS laisser d'enfants se tenir debout sur quelque tiroir, porte ou étagère que ce soit, y grimper ou s'y suspendre.
- NE JAMAIS ouvrir plus d'un tiroir à la fois.
- NE PAS mettre hors d'état de fonctionnement ou ne pas retirer le système de blocage individuel des tiroirs ; il constitue un important élément de stabilité et de sécurité.
- Placer les choses les plus lourdes dans les tiroirs du bas.
- Lire et suivre attentivement toutes les étapes de la notice de montage.

Español





ADVERTENCIA:

Han muerto niños por el vuelco de muebles

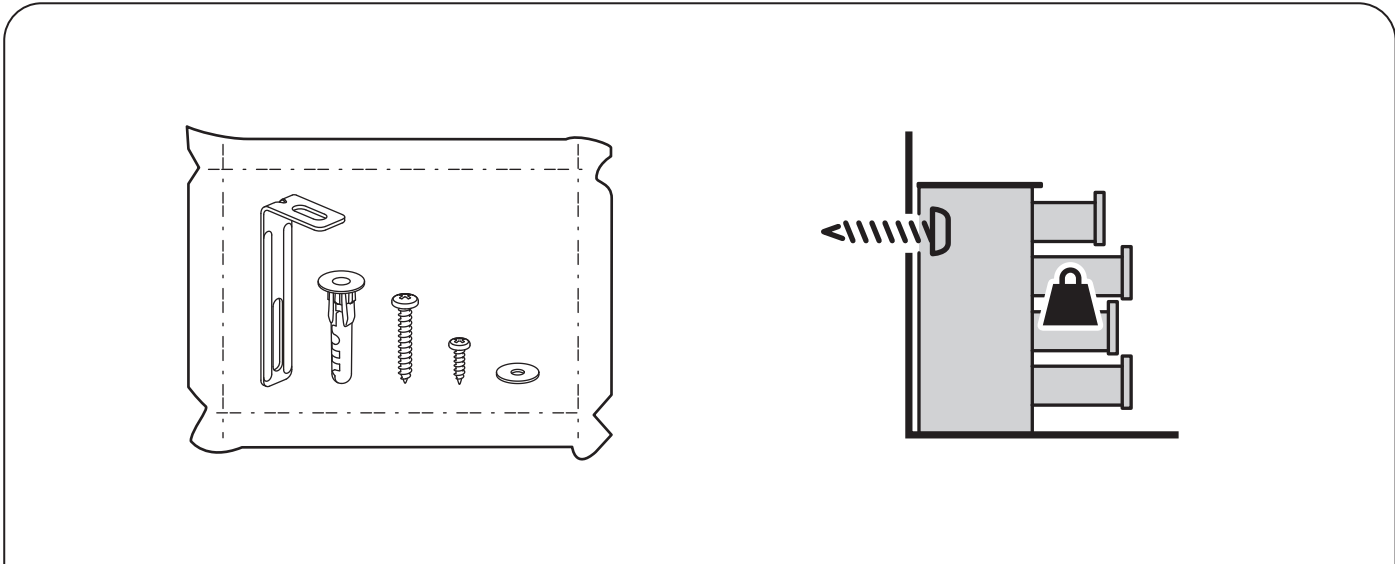
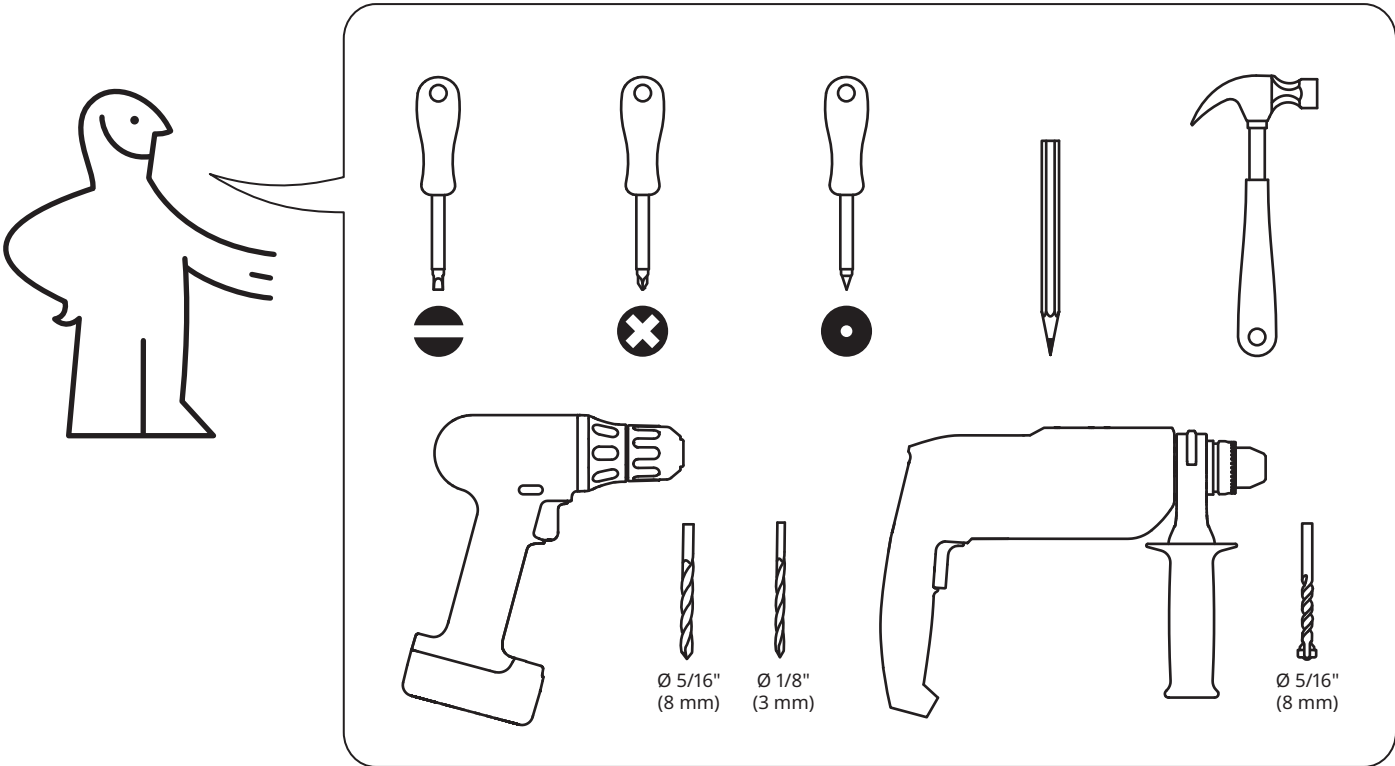
Para limitar el riesgo de vuelco de los muebles:

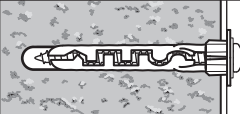
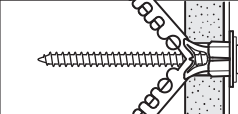
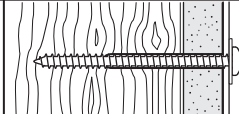
- Instala SIEMPRE el dispositivo antivuelco que se suministra.
- No pongas NUNCA un televisor encima de este producto.
- No permitas NUNCA que los niños se pongan de pie, trepen o se cuelguen de los cajones, puertas o baldas.
- No abras NUNCA más de un cajón a la vez.
- NO desconectes ni quites el sistema de bloqueo de los cajones; se trata de un sistema importante de seguridad y estabilidad.
- Mete los objetos más pesados en los cajones inferiores.
- Lee y sigue cada paso de las instrucciones cuidadosamente.



	A	B	C
 www.IKEA.com/secure-it			
	Ø 5/16" (8 mm) 	Ø 5/16" (8 mm) 	Ø 1/8" (3 mm) 

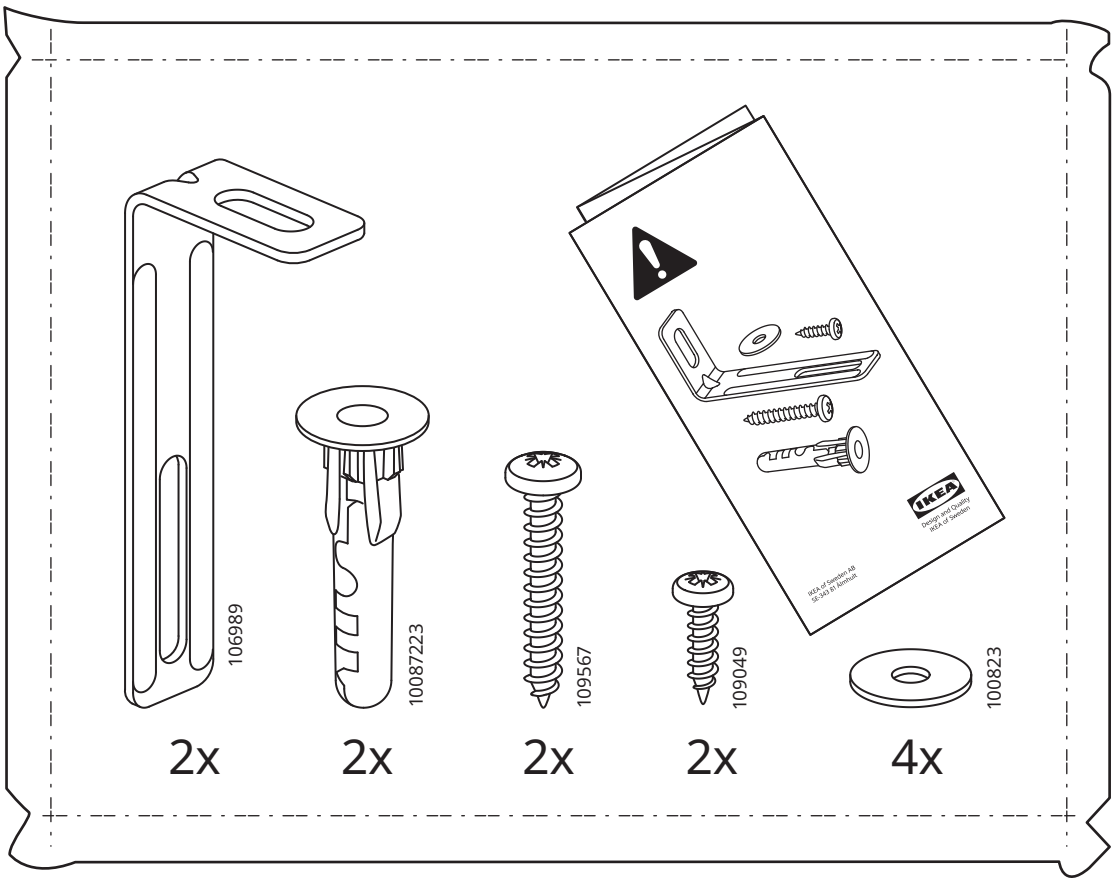
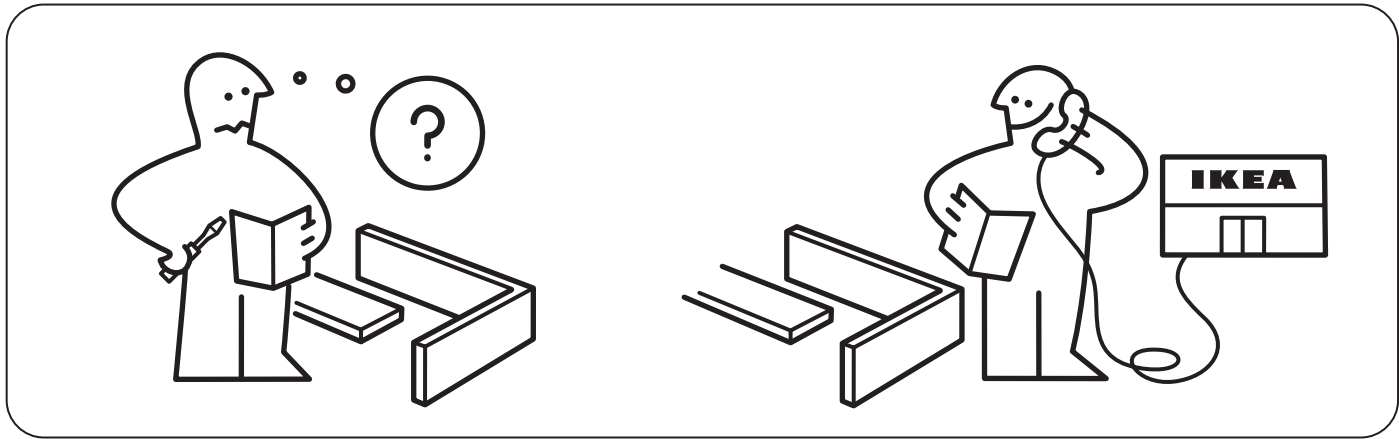
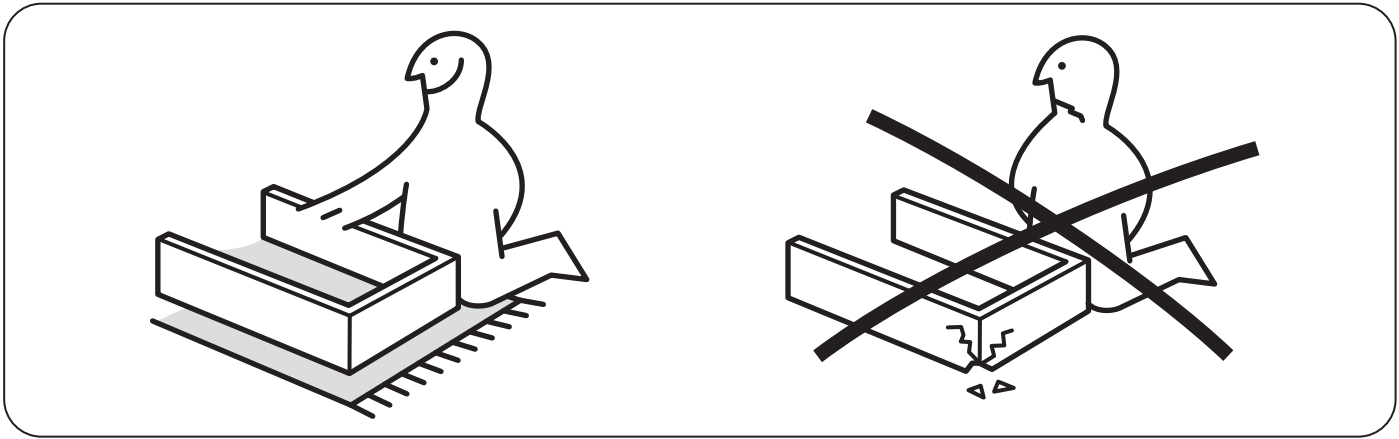

370766

1

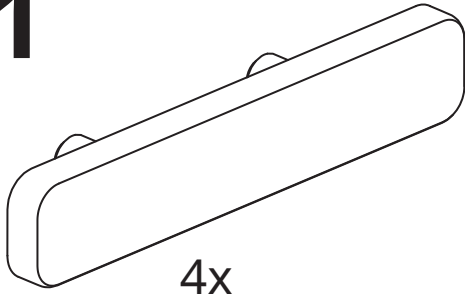

4x

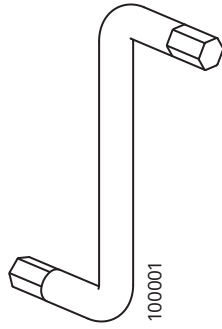

1x

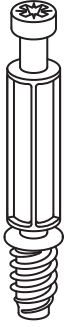
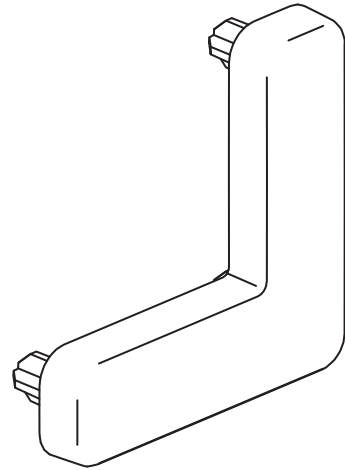

118331

22x

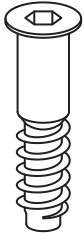

100217

8x



101345

22x

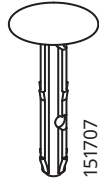

151707

8x

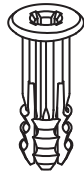

151708

8x

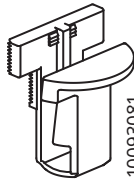

10093081

12x



10093082

28x

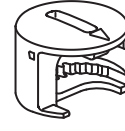

119250

22x

119252



100359

2x



146114

48x

2

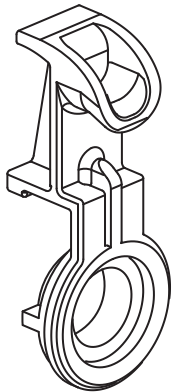

10133139

8x



145718

32x

159553

10120234

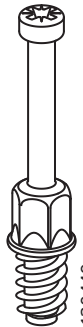

130449

32x

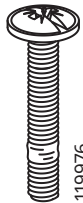

119976

16x

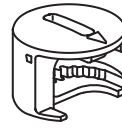

119030

64x

118224

117434

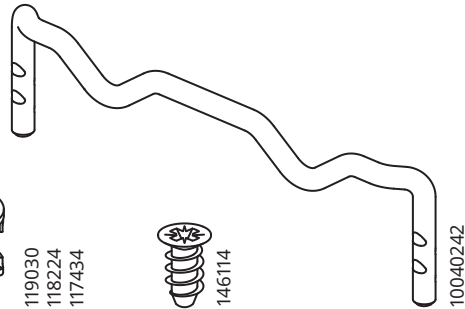

146114

48x

10040242

8x

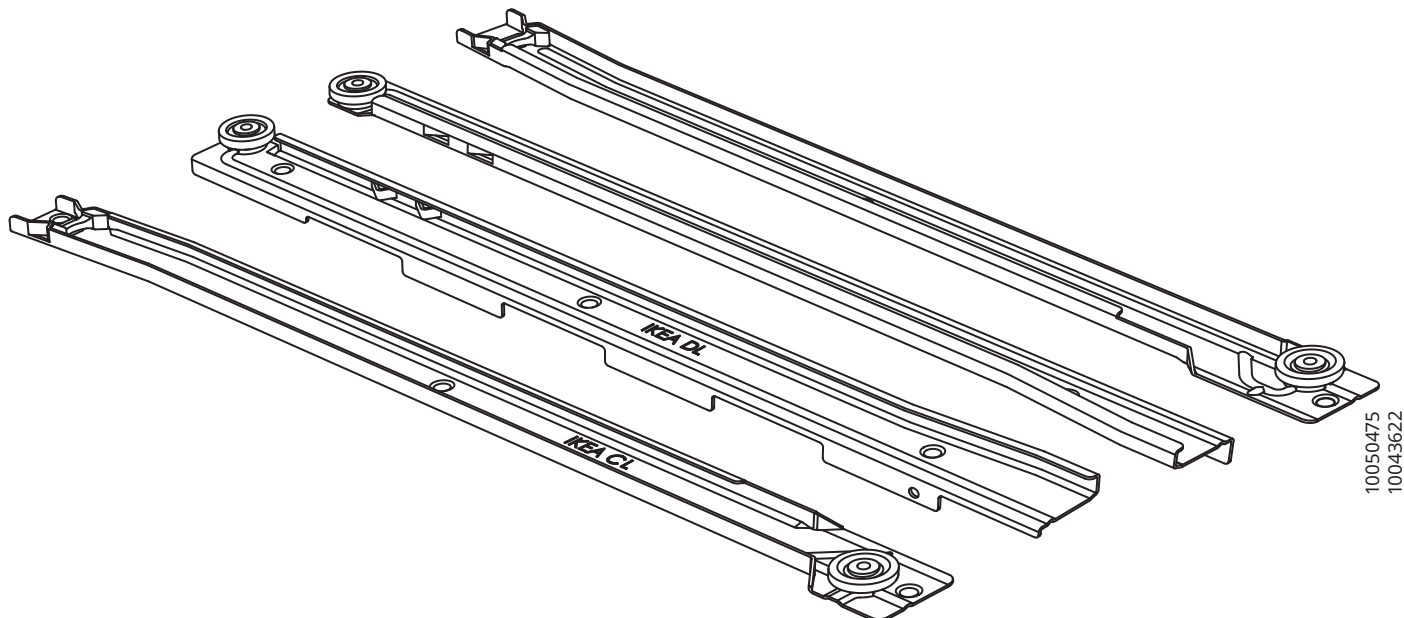

10050475
10043622

8x

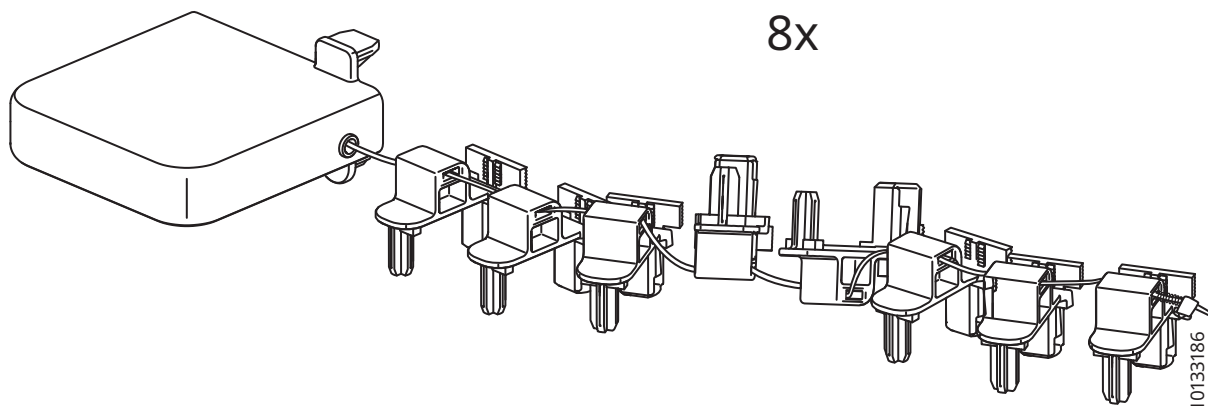

10133186

2x

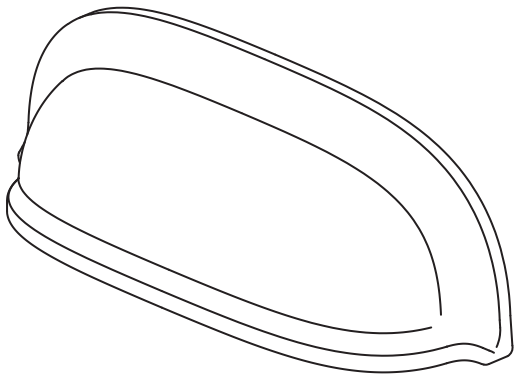

10142618

8x

1

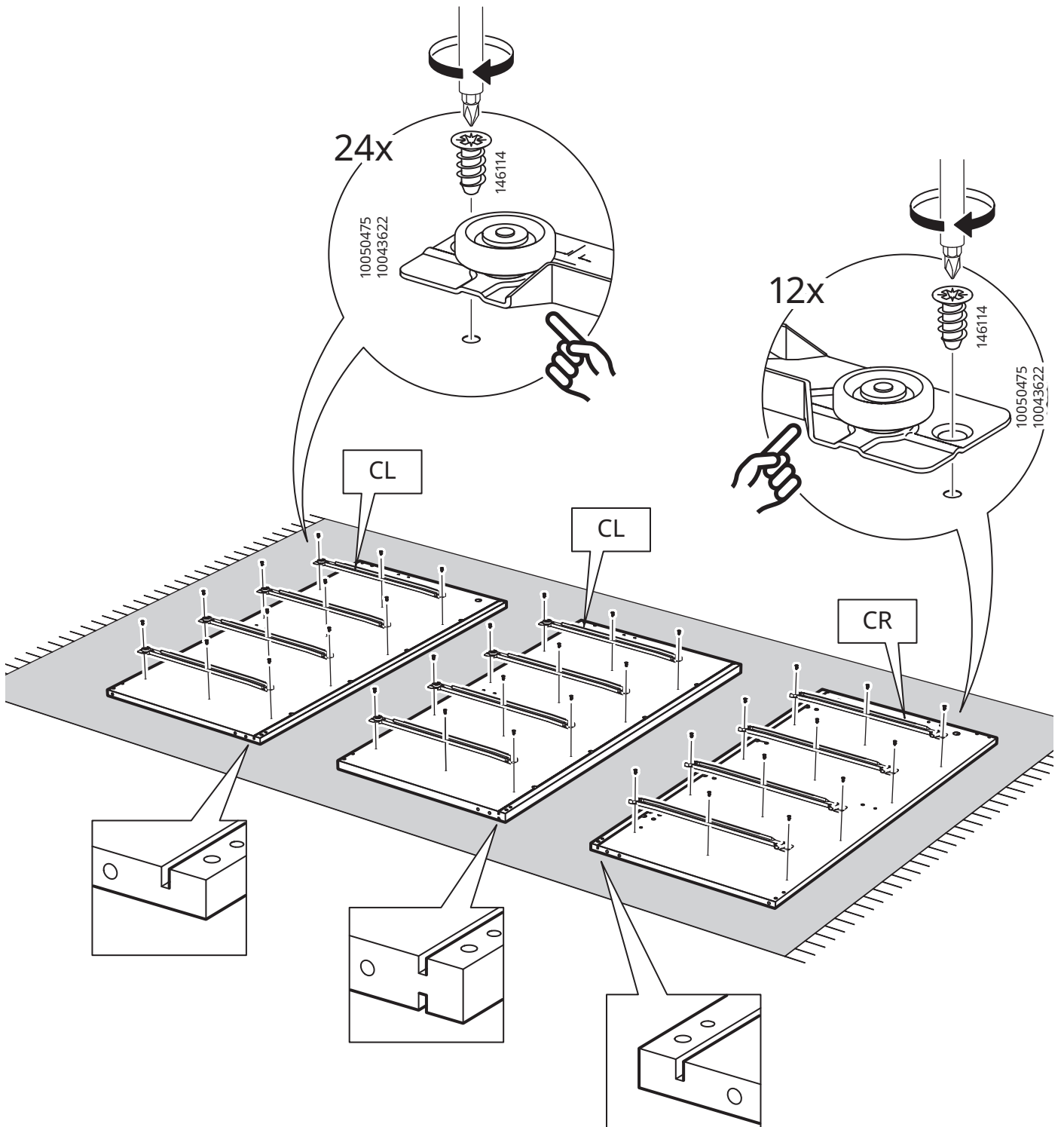

2

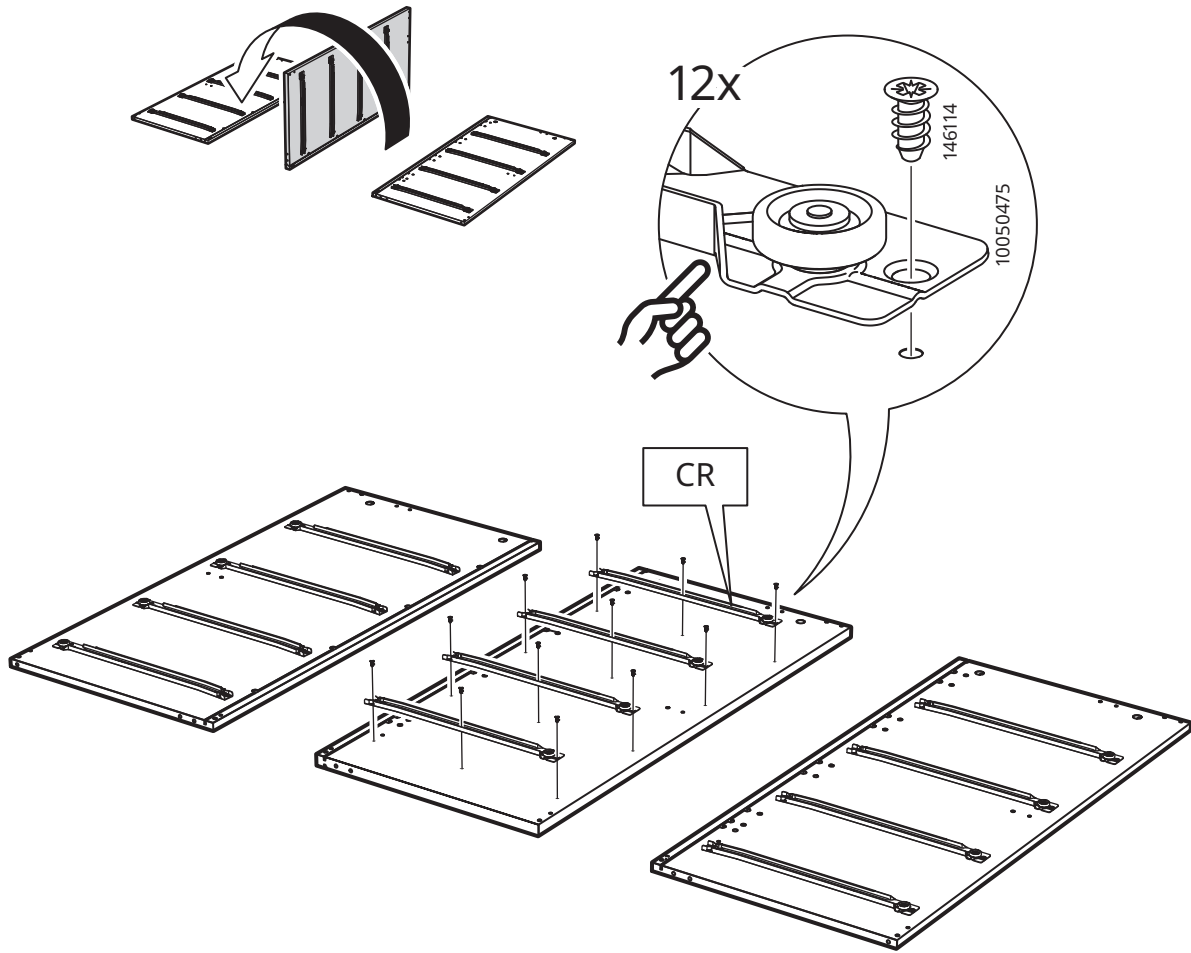

3

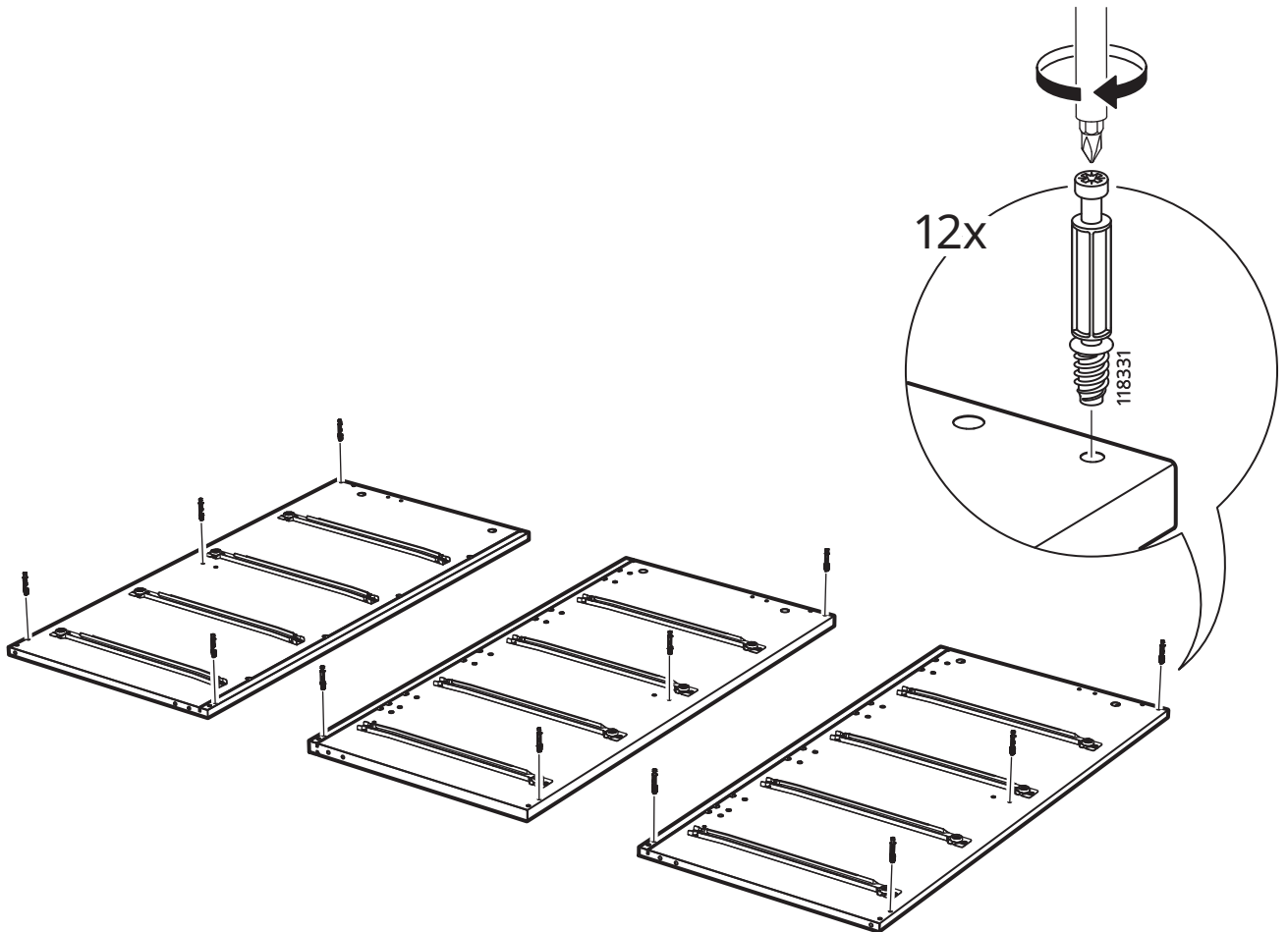

4

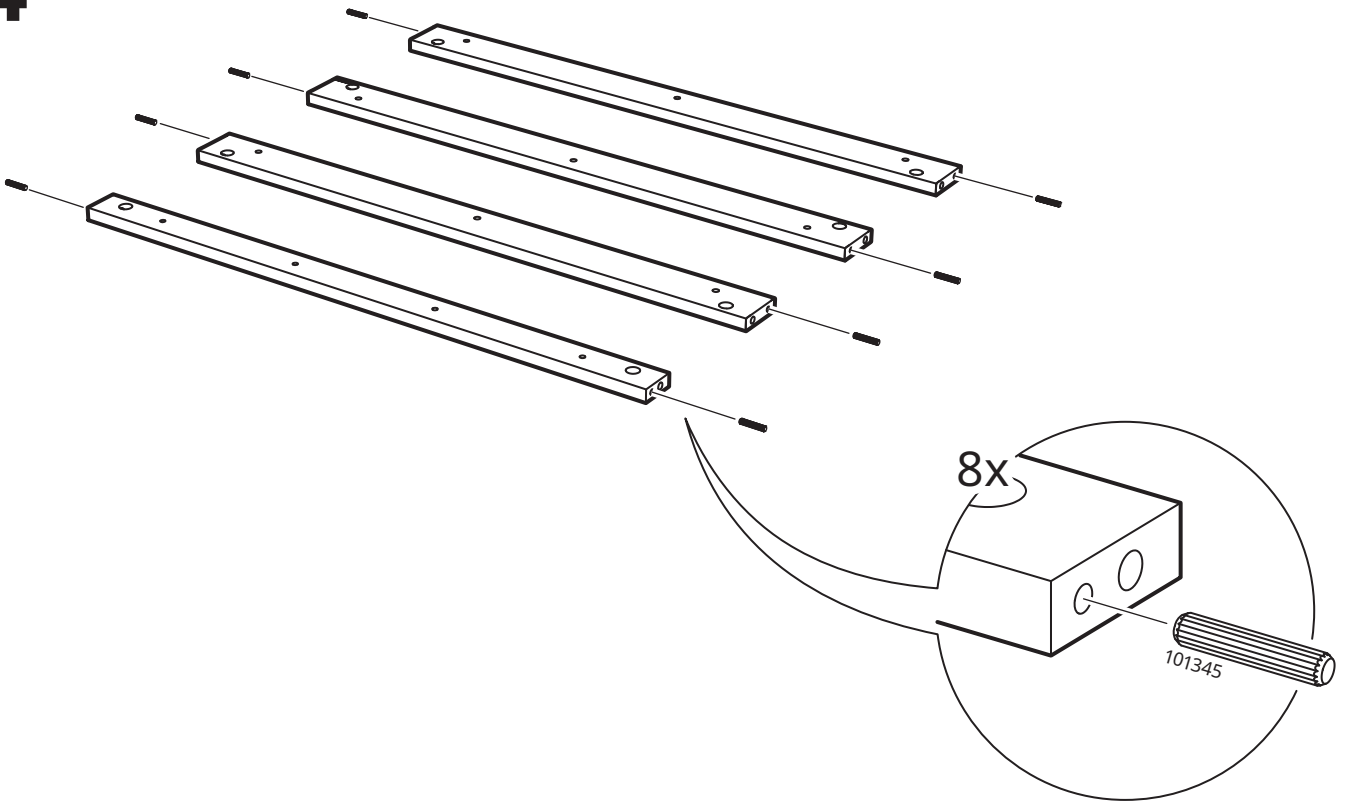

5

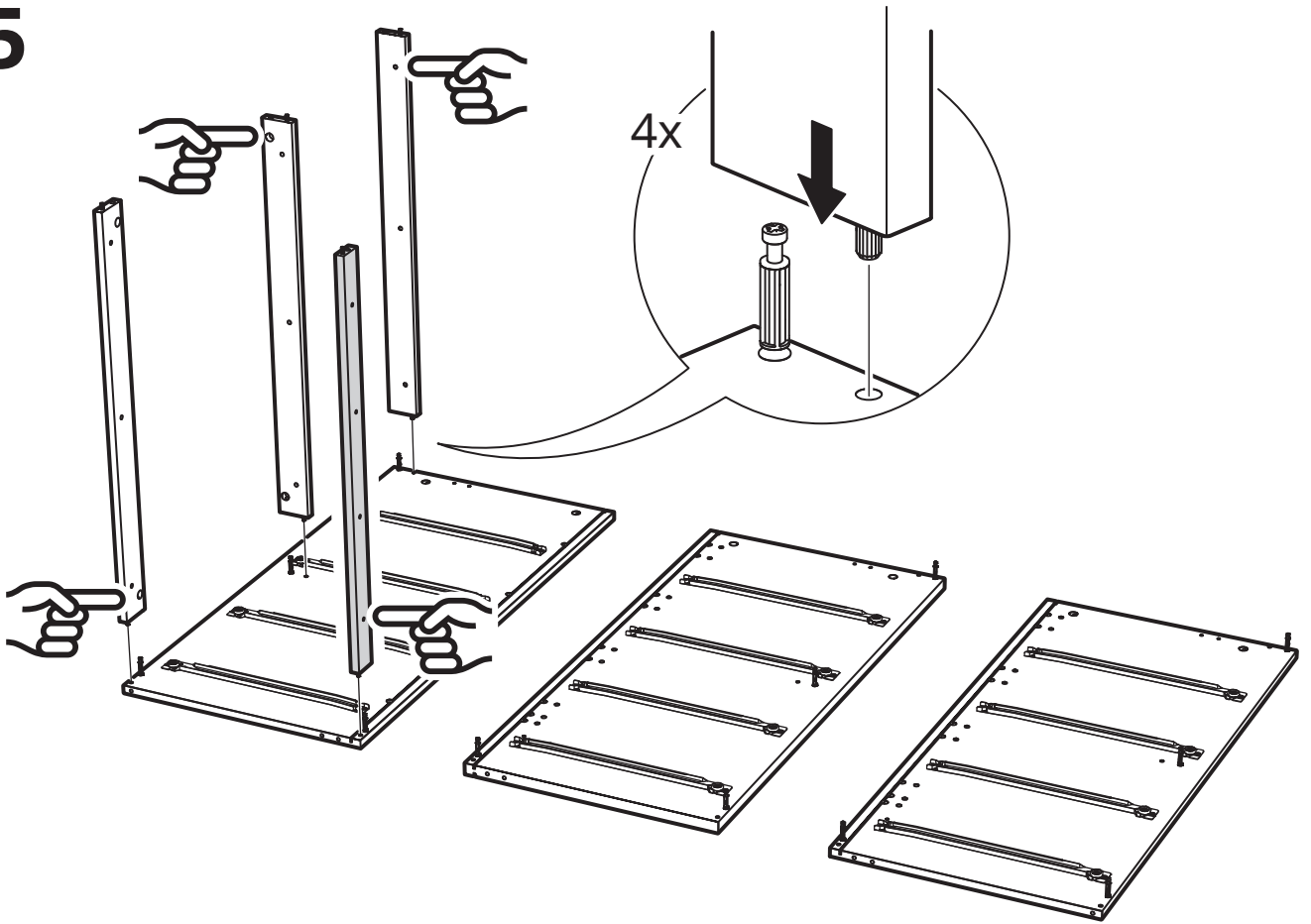

6

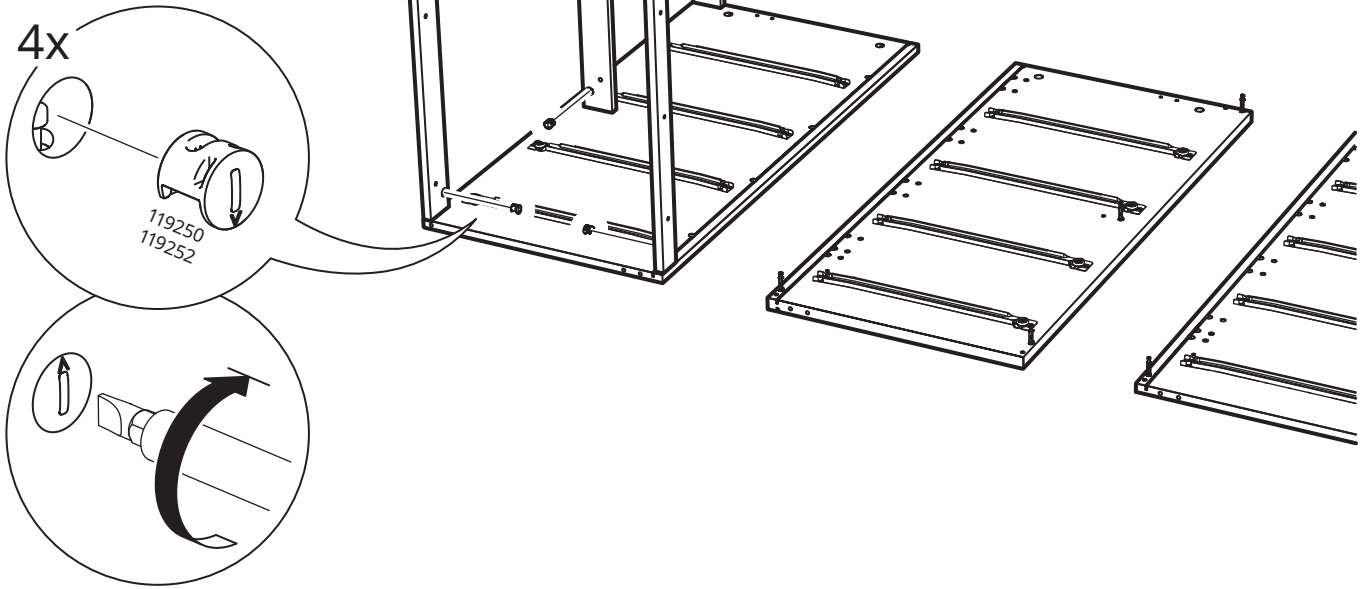

7

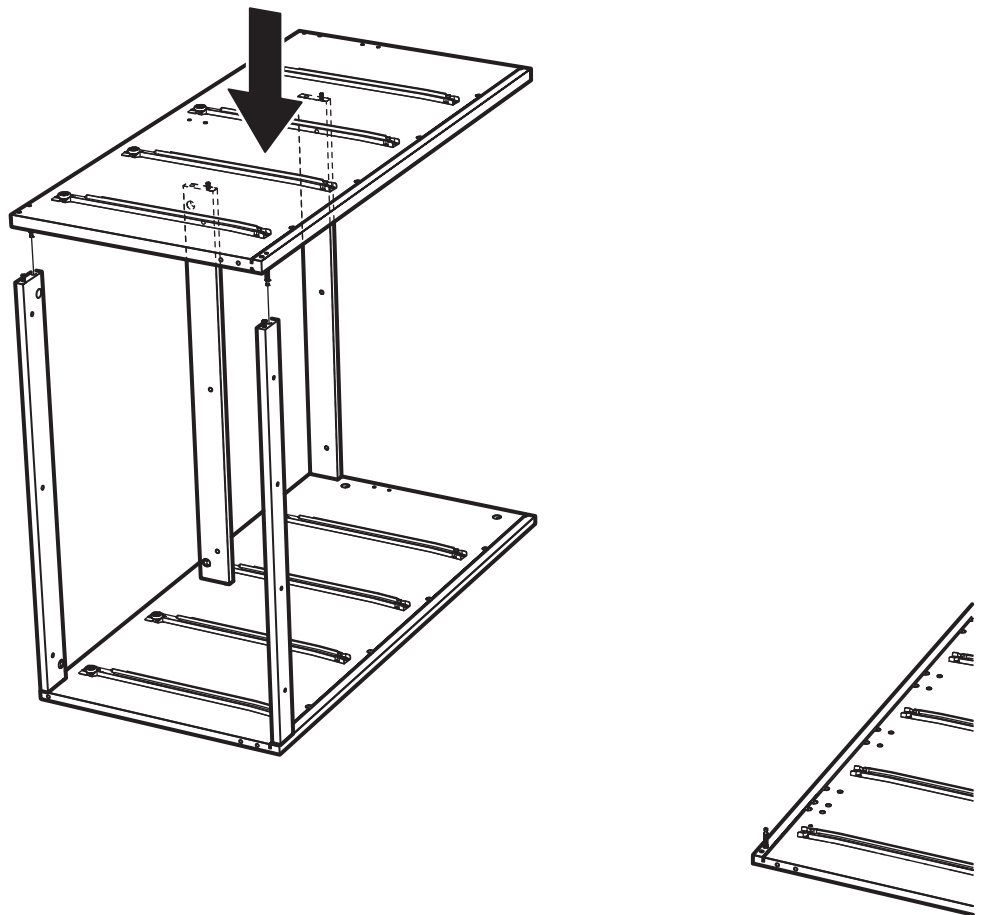

8

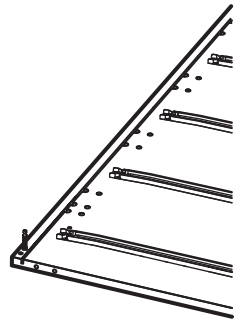
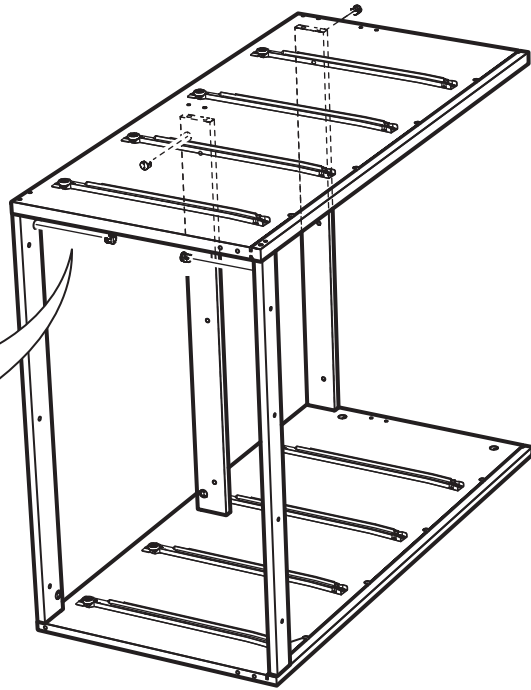
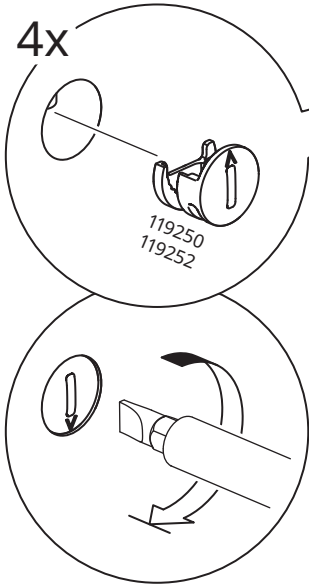

9

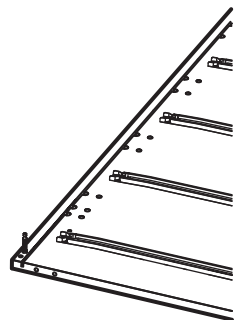
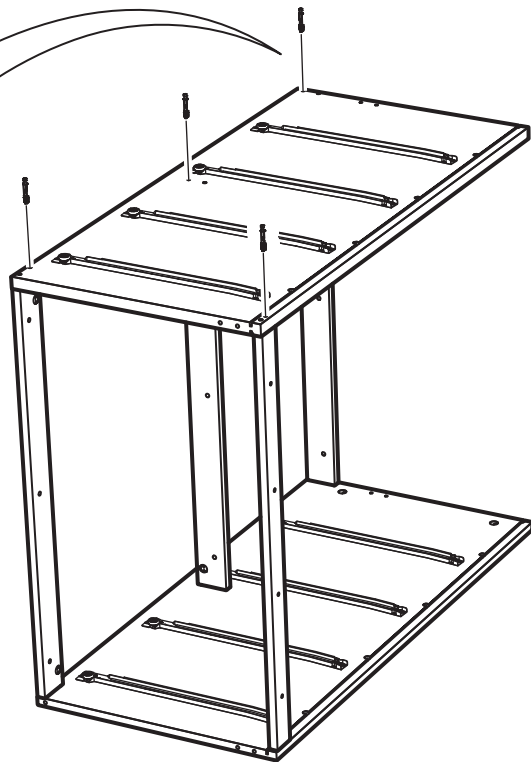
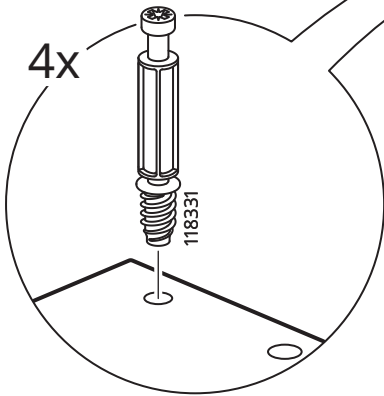

10

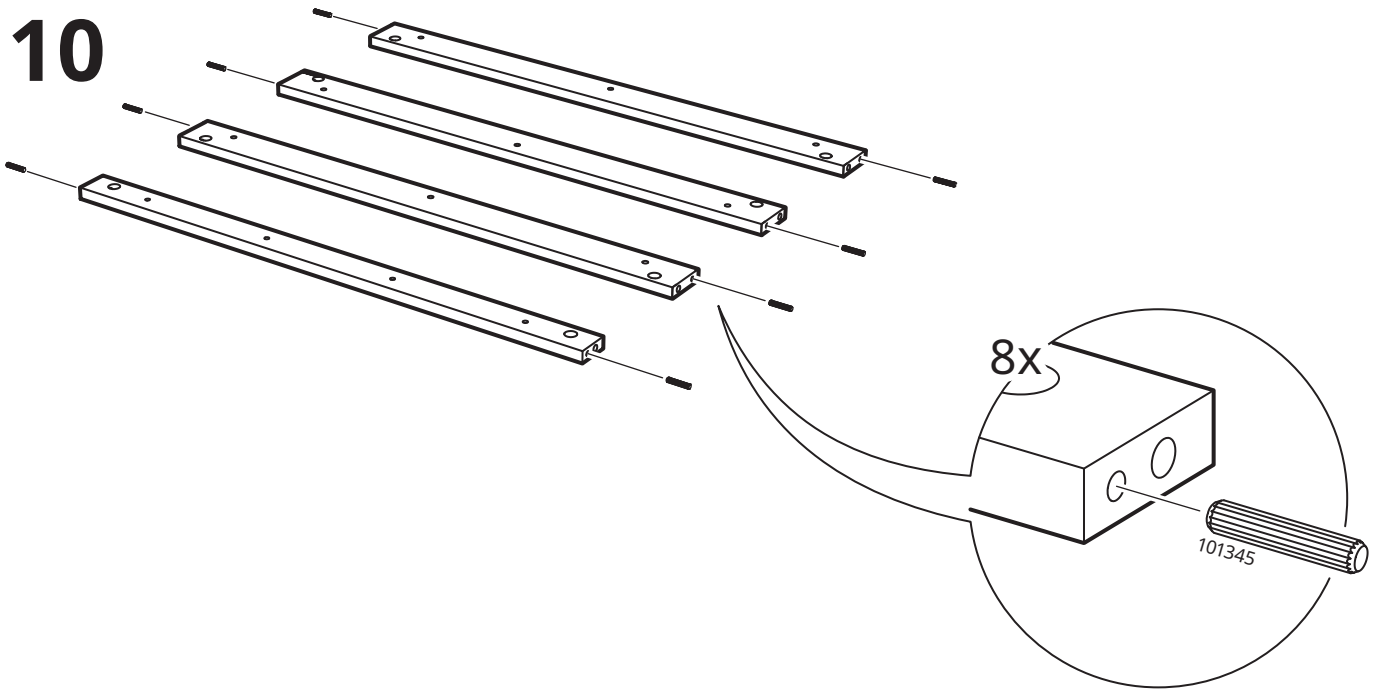

11

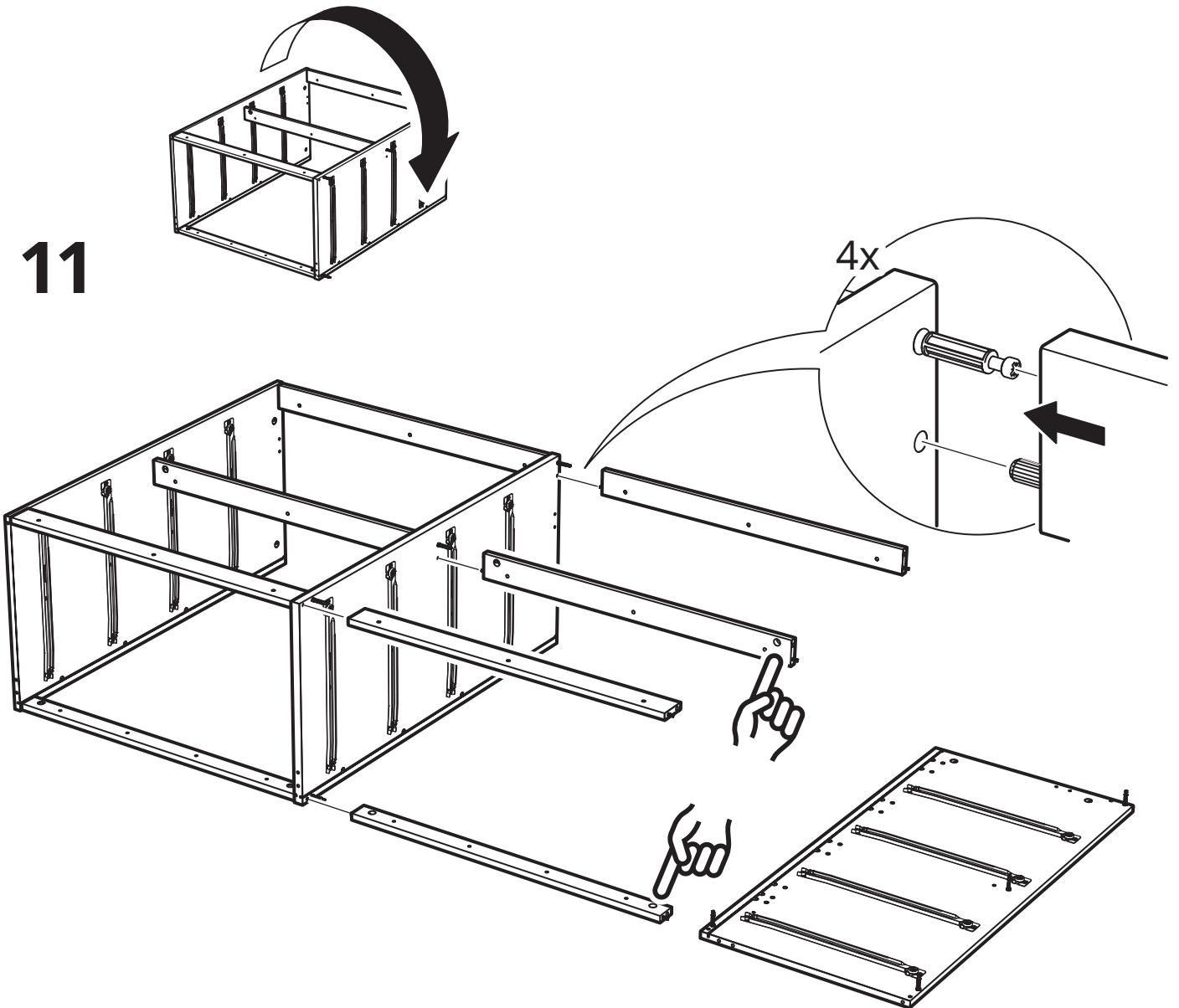

12

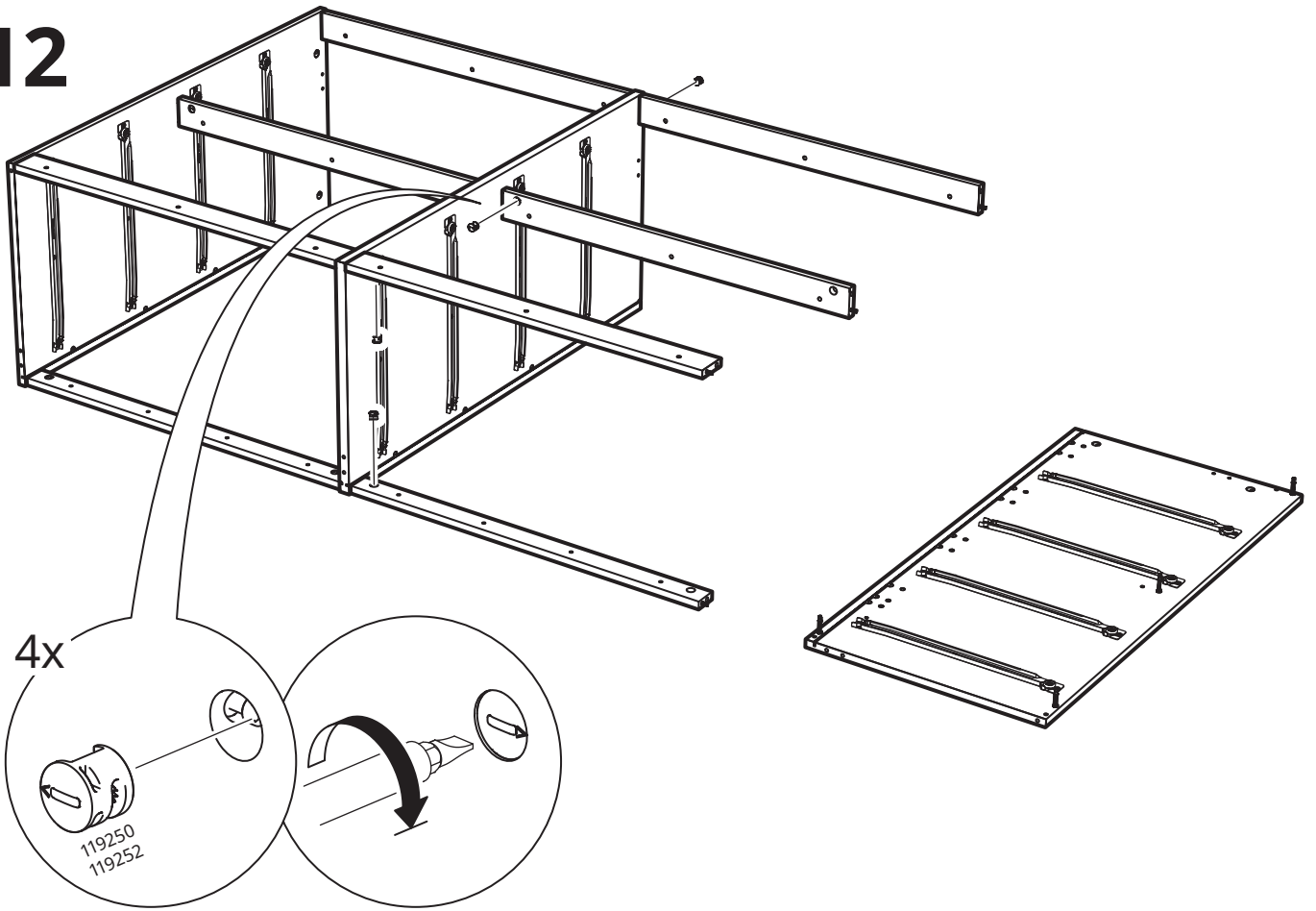

13

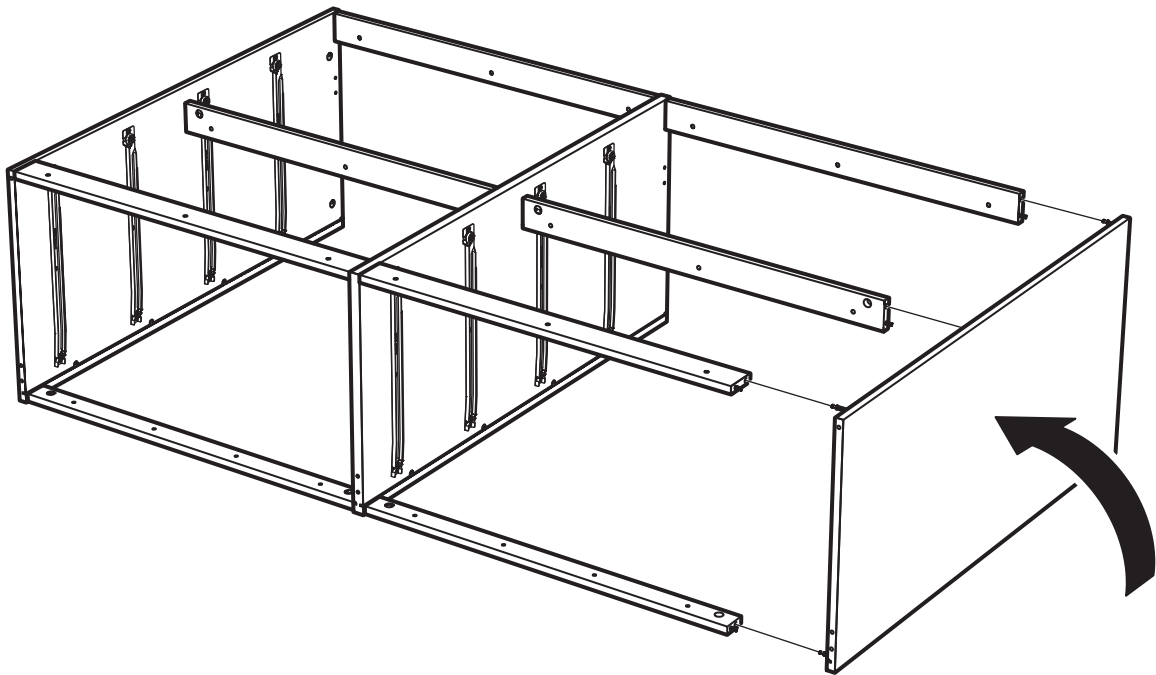

14

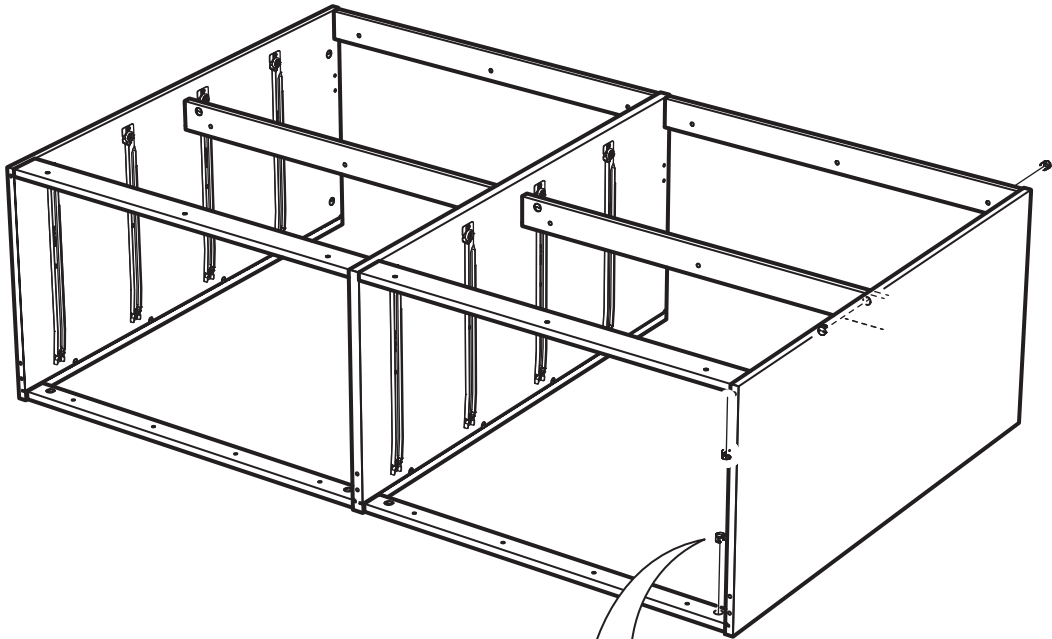

4x

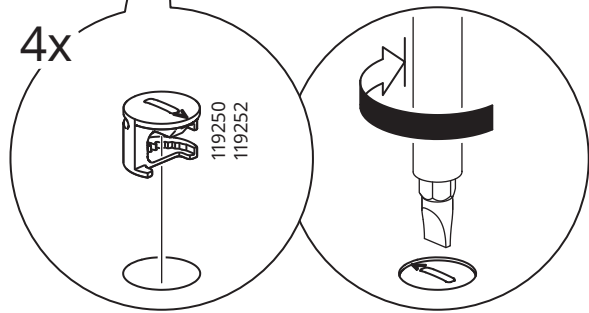

119250
119252

15

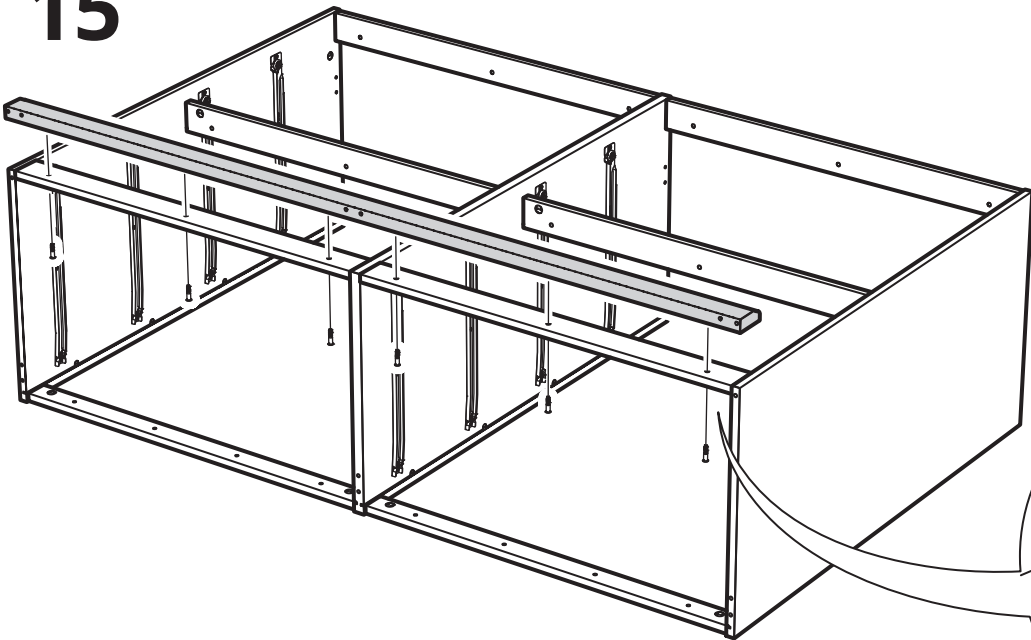

6x

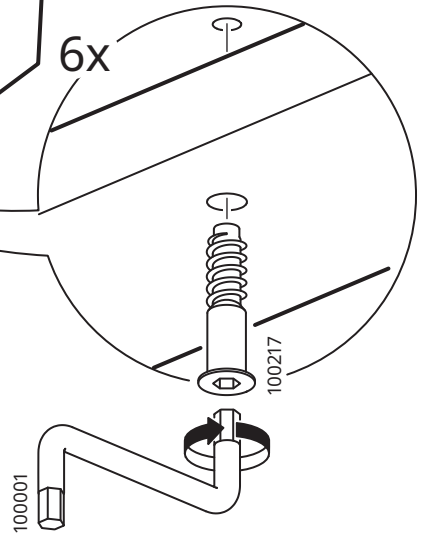

100217

100001

16

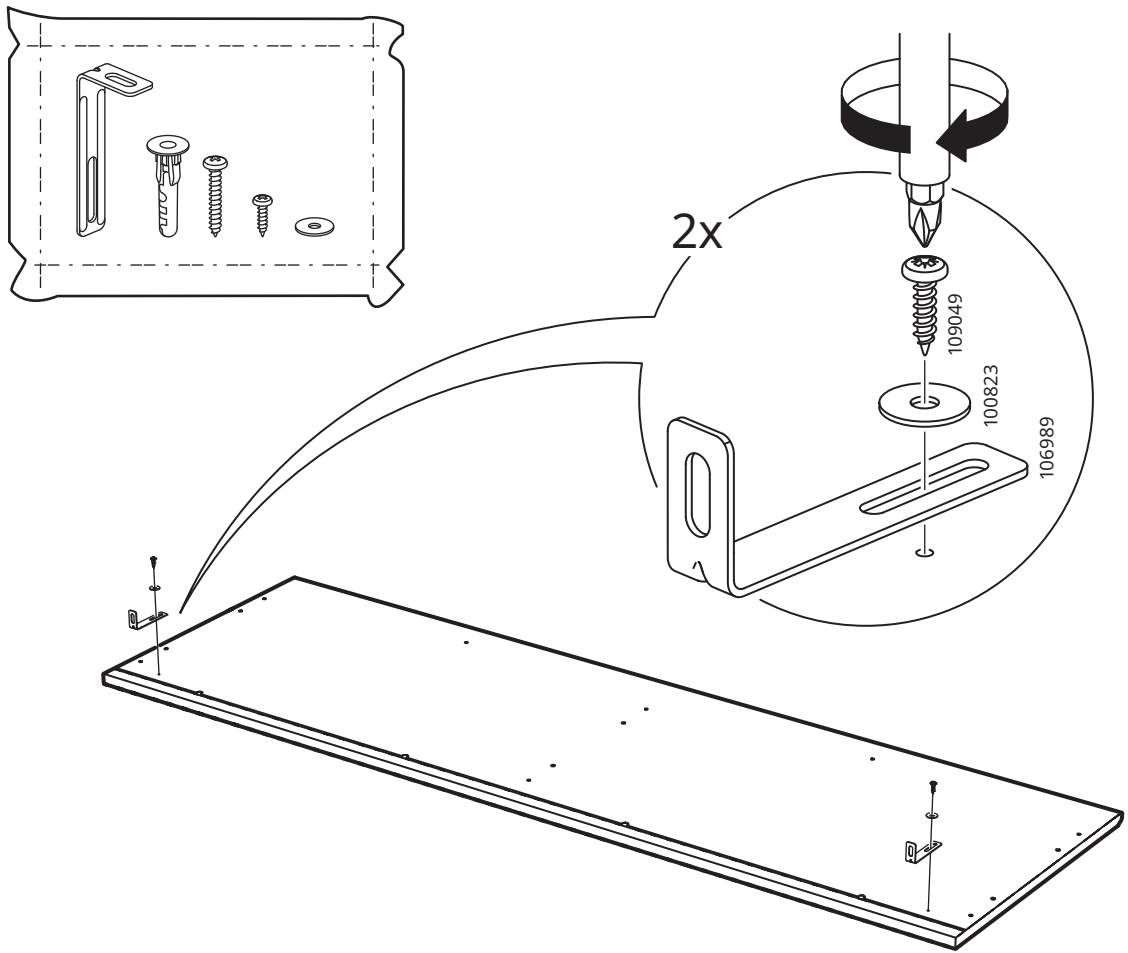

17

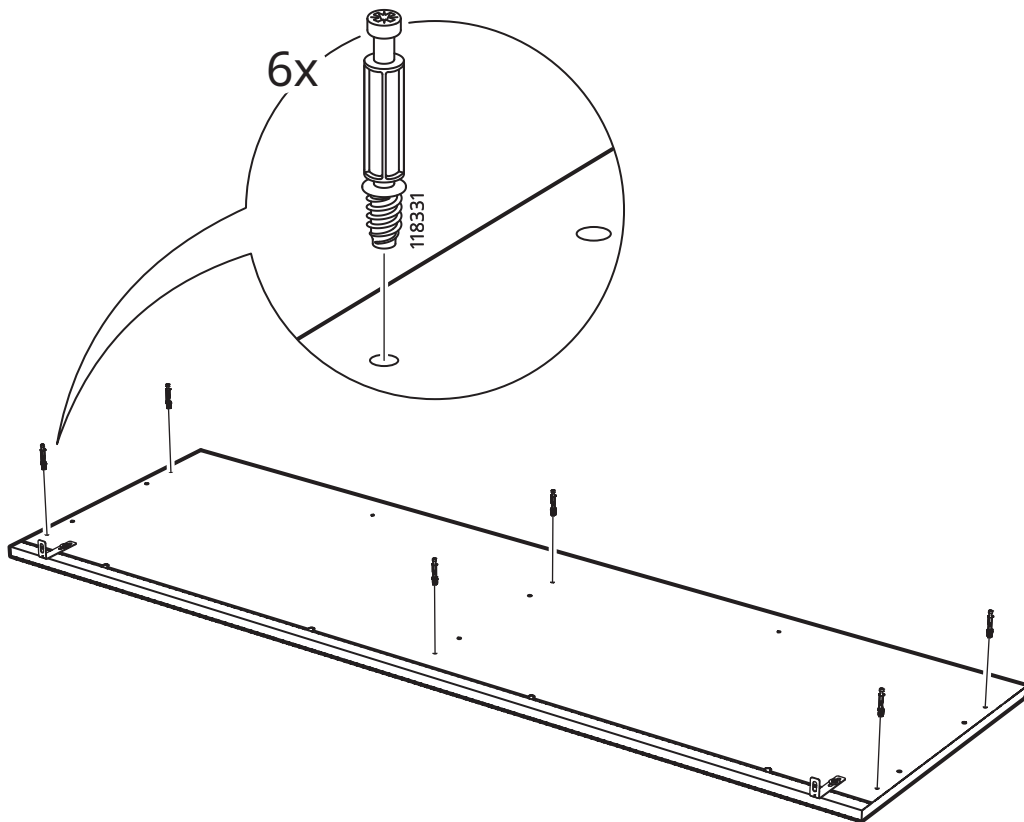

18

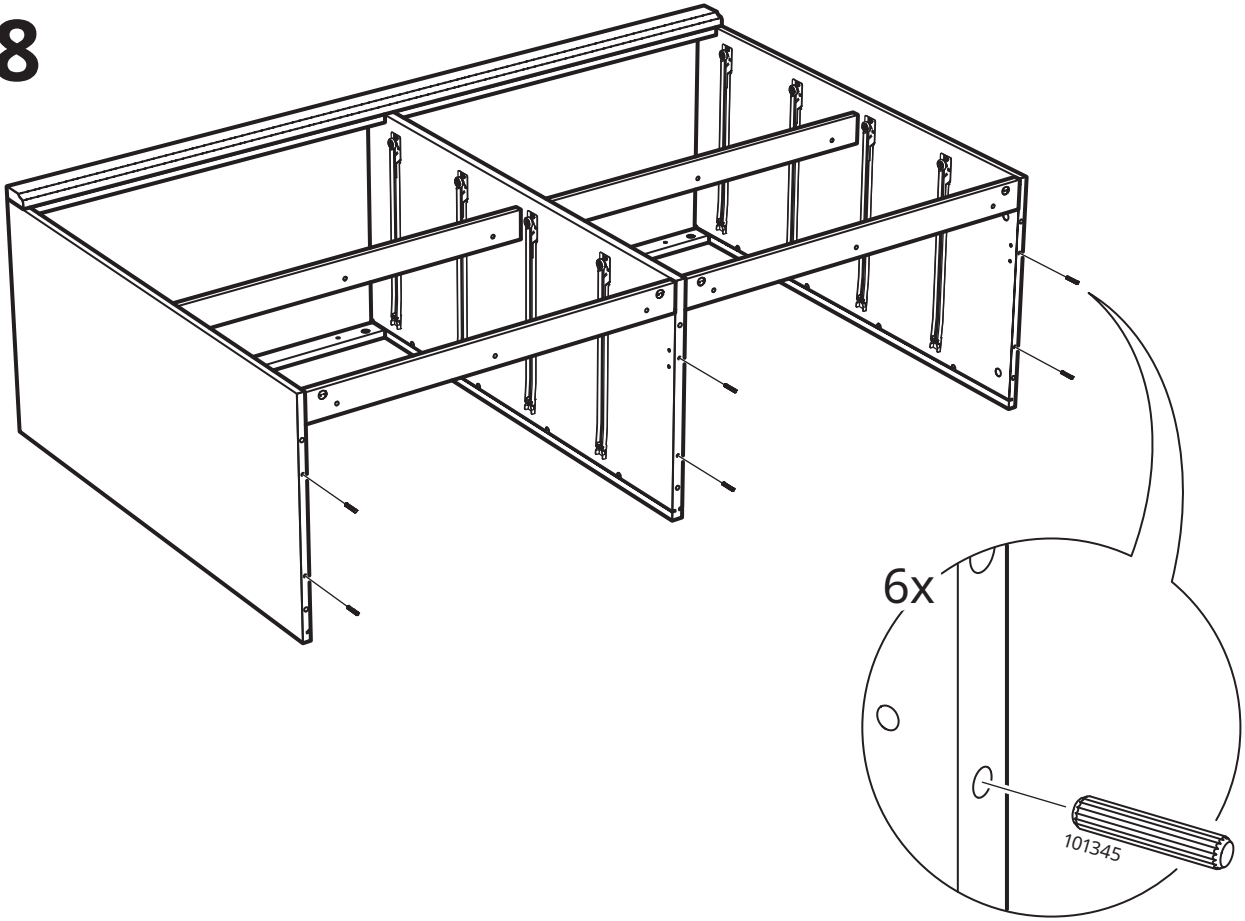

19

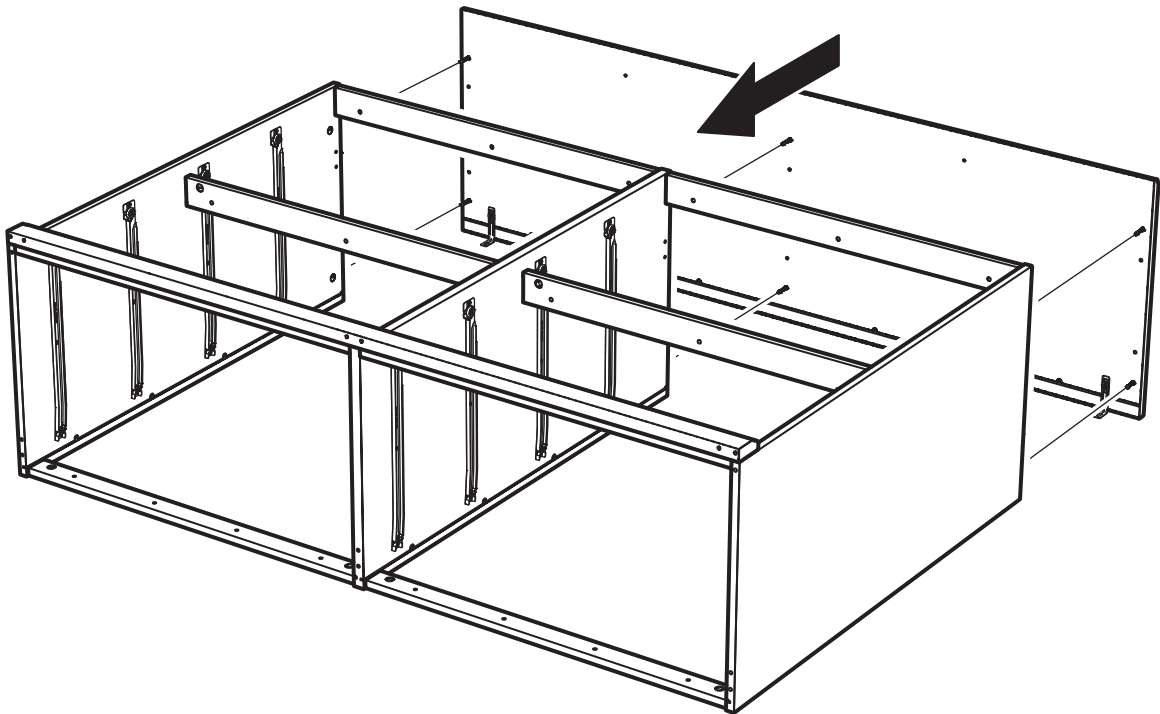

20

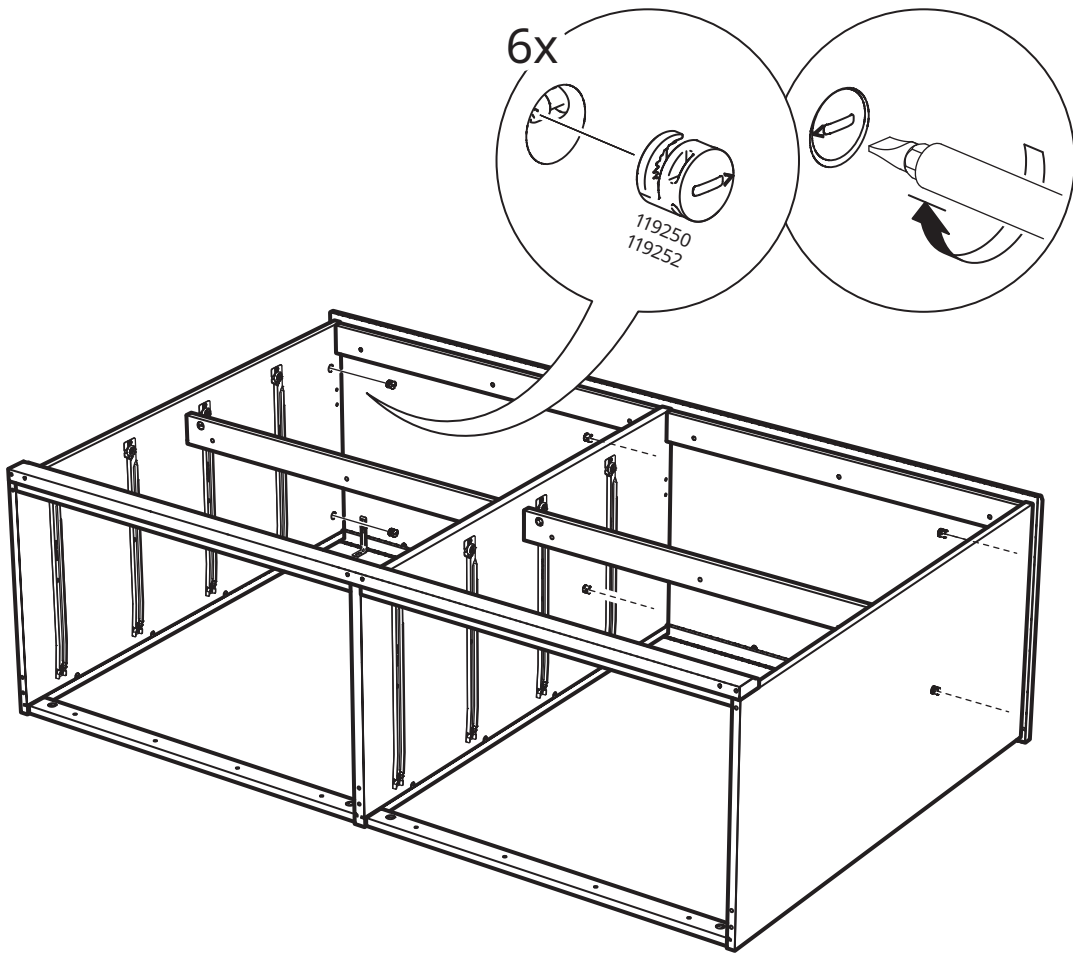

21

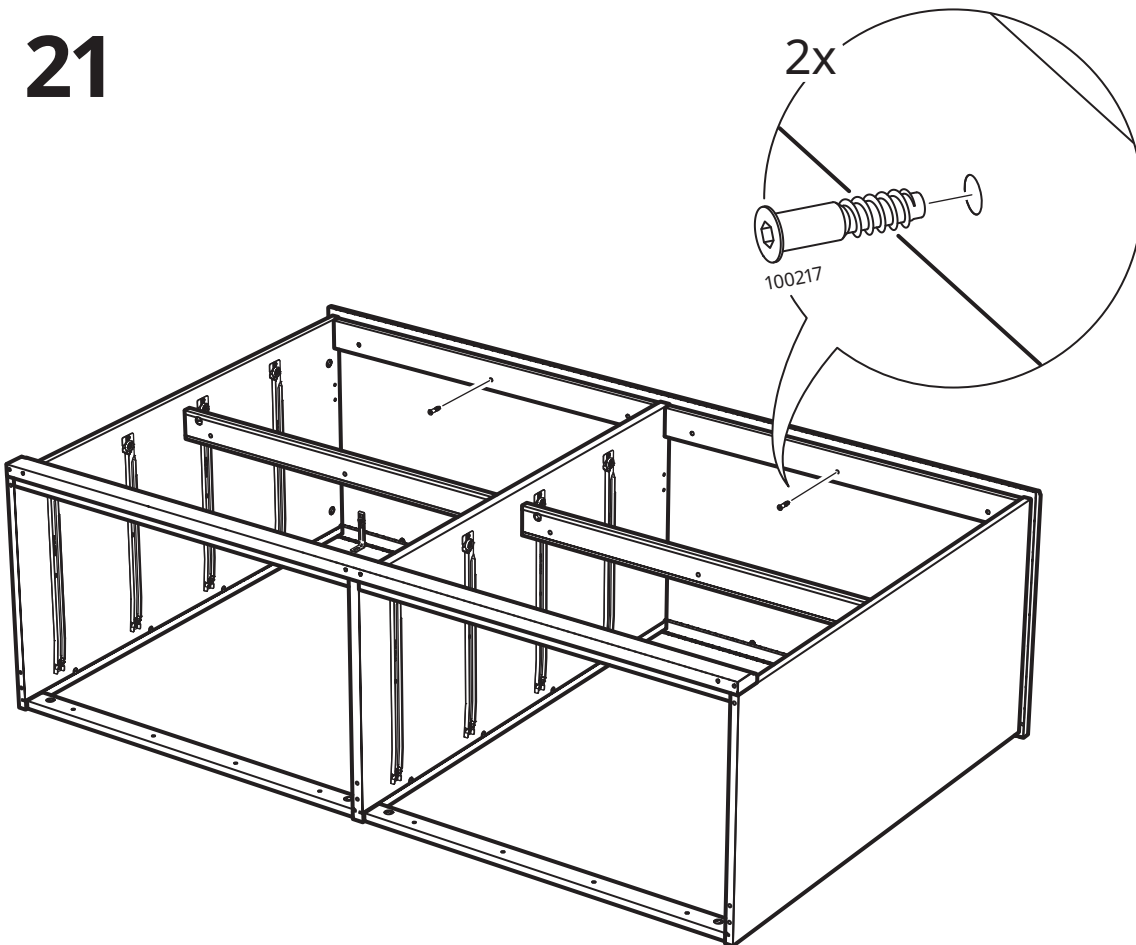

22

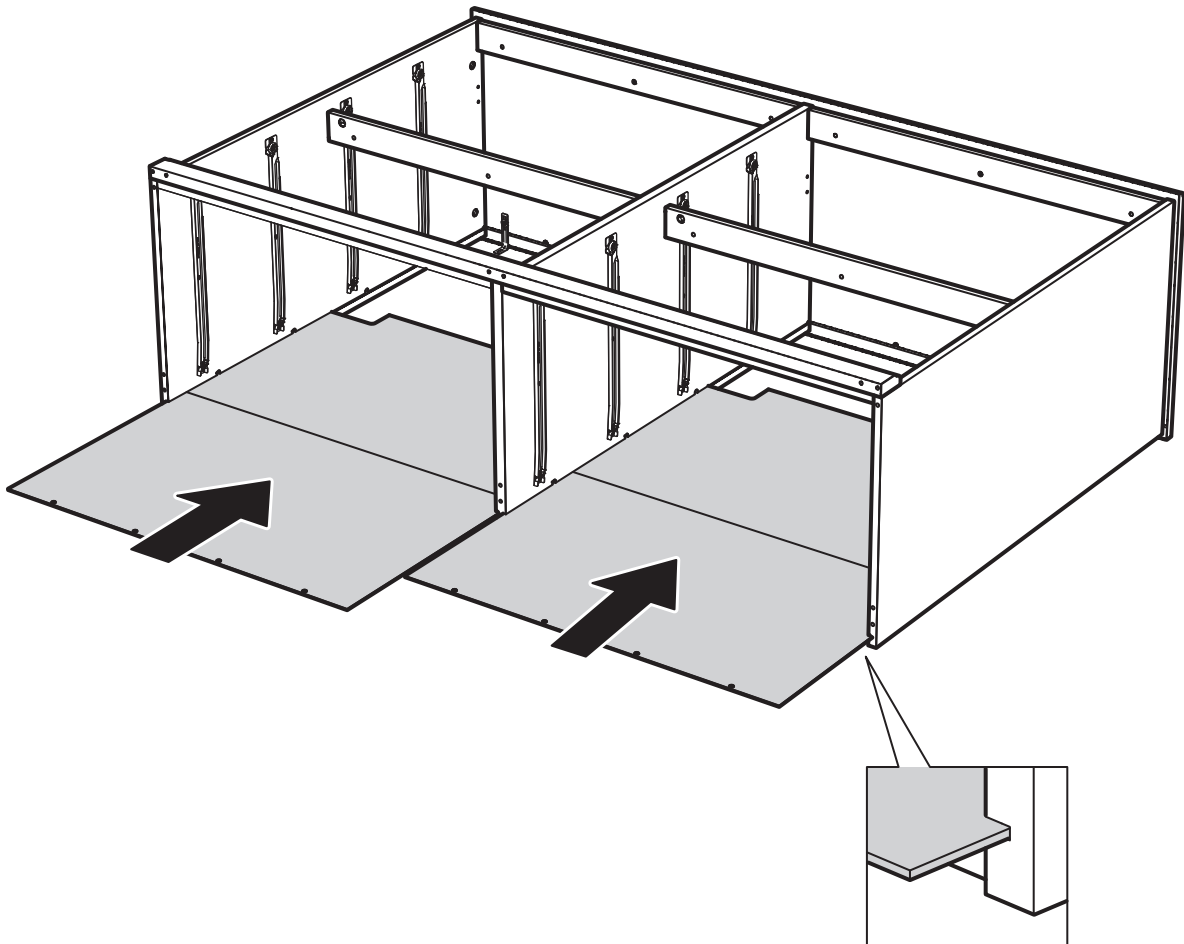
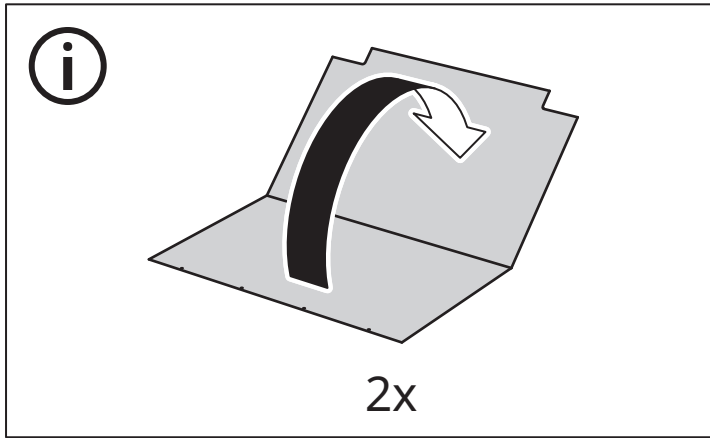

23

8x

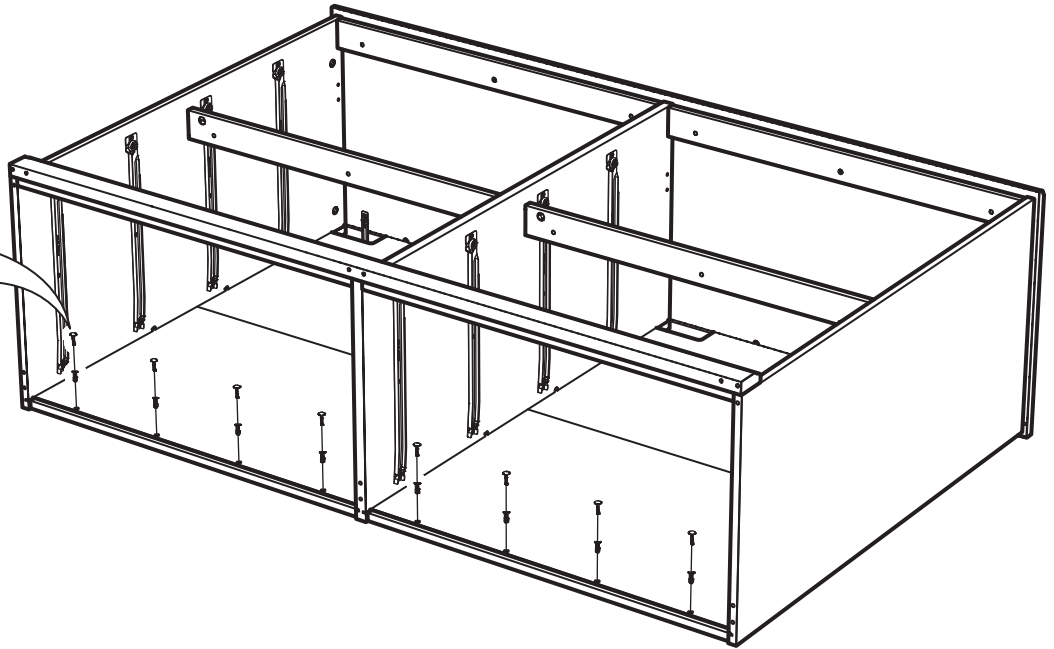

24

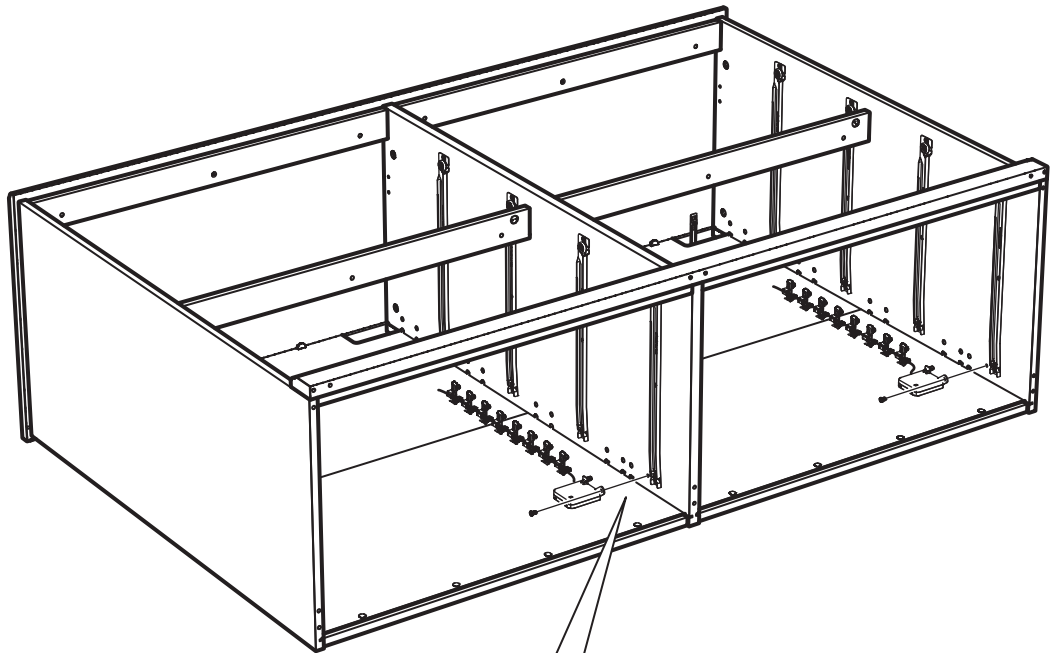

2x

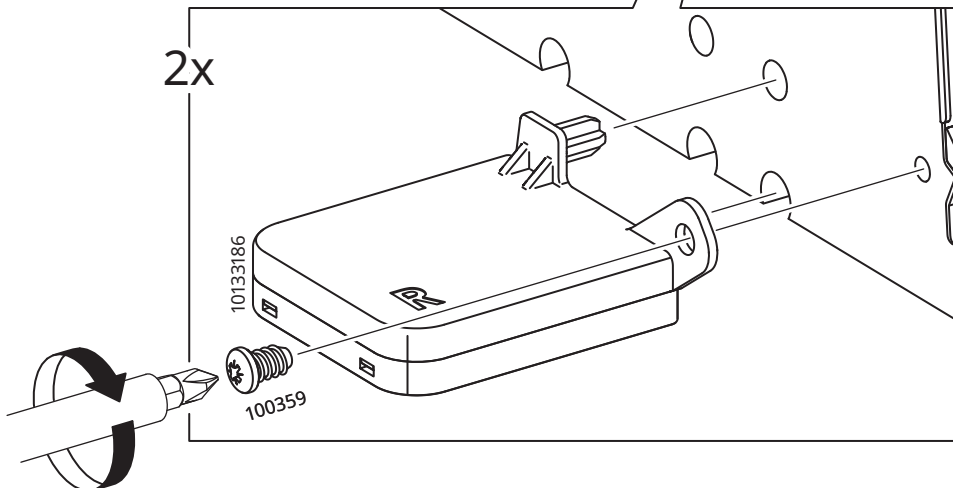

25

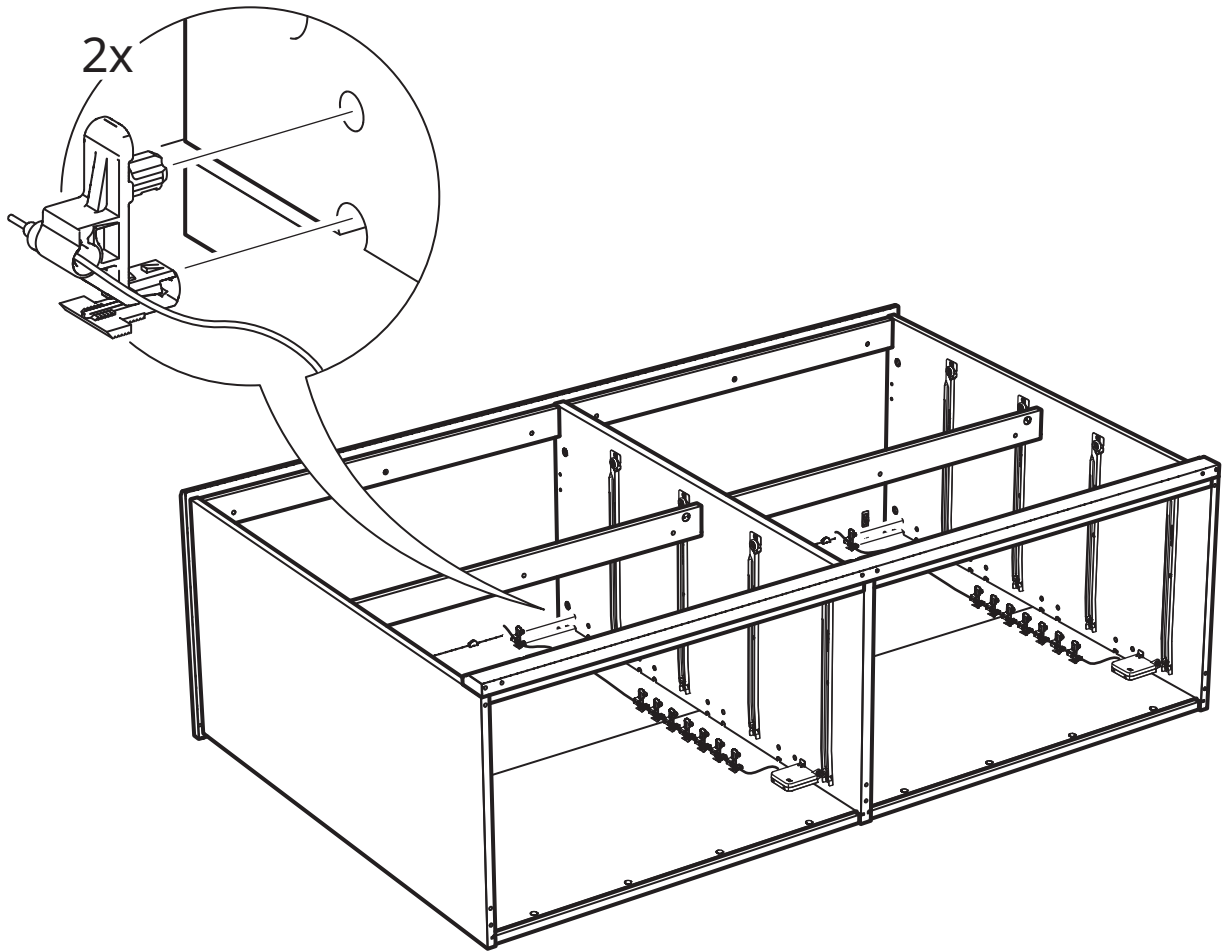

26

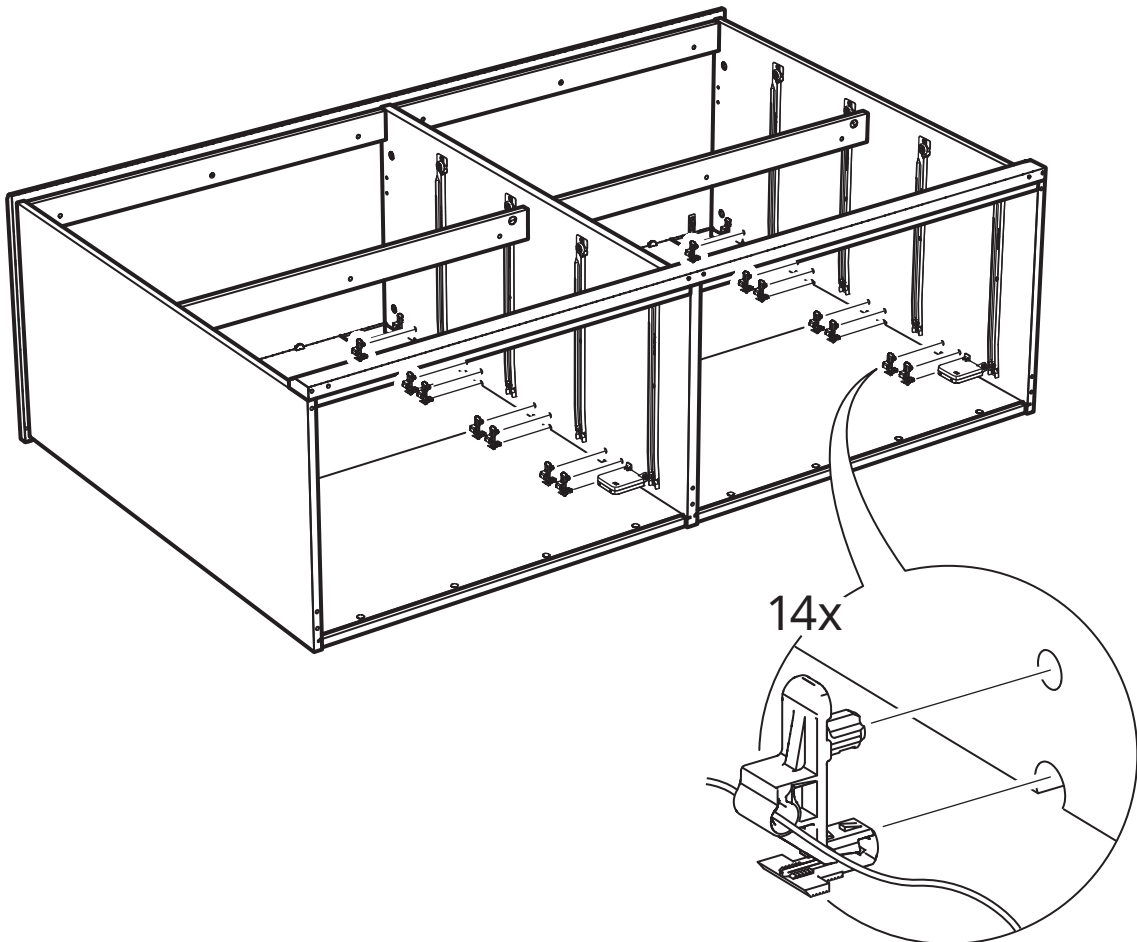

27

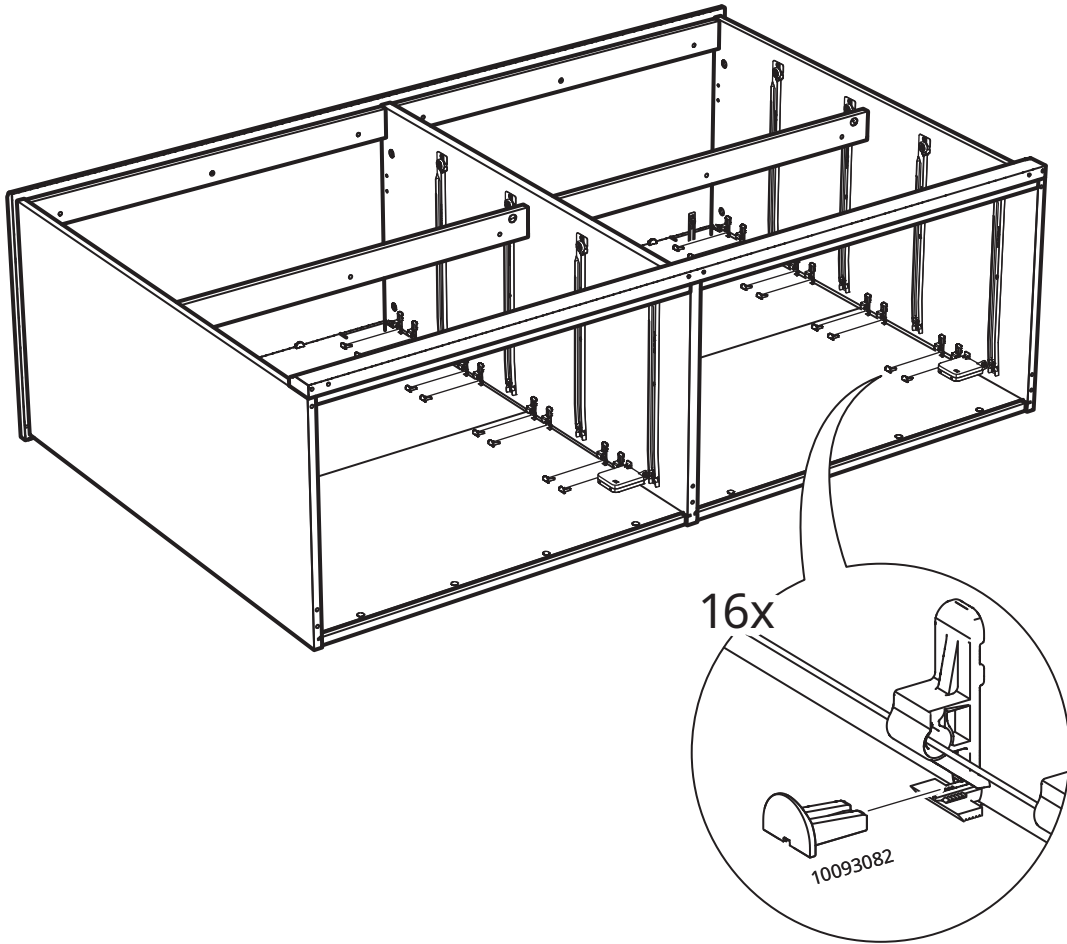

28

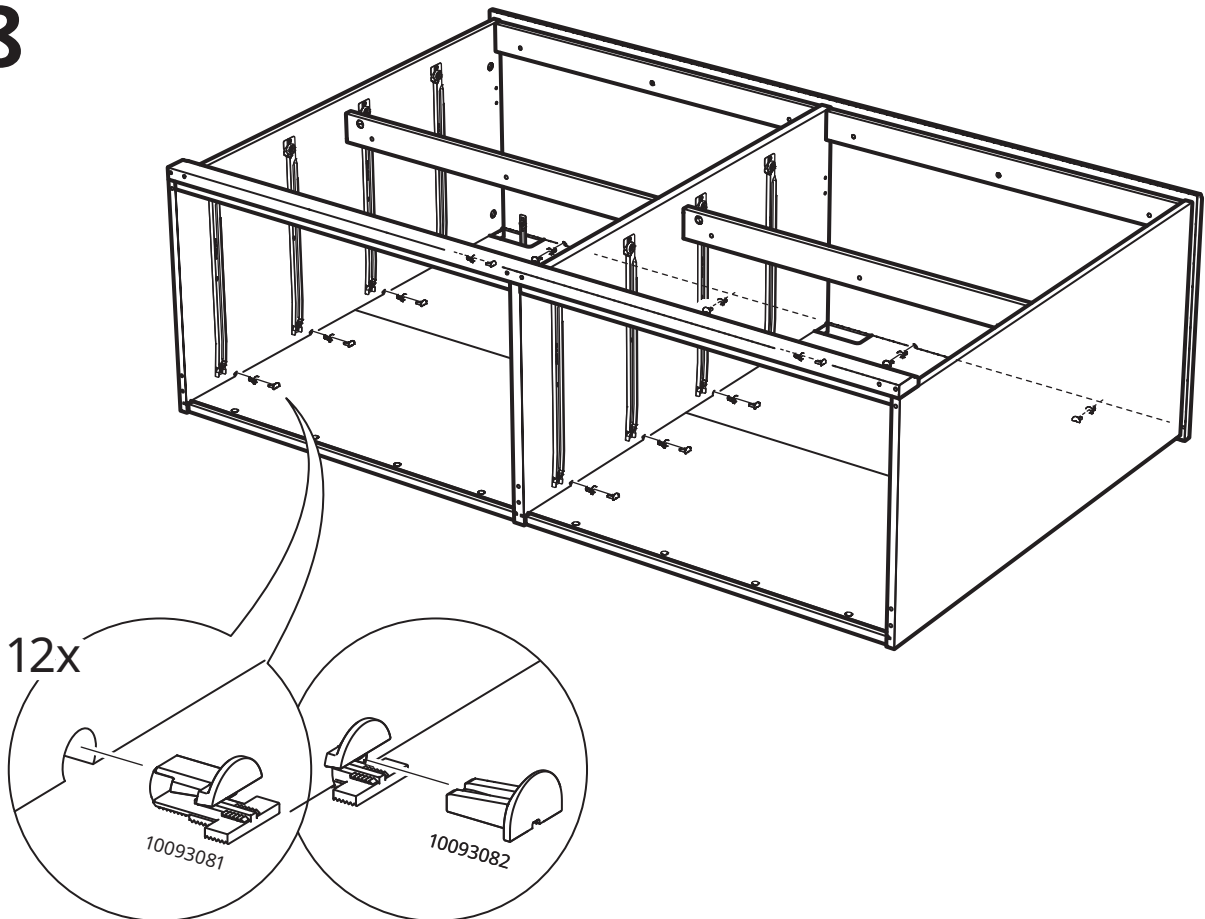

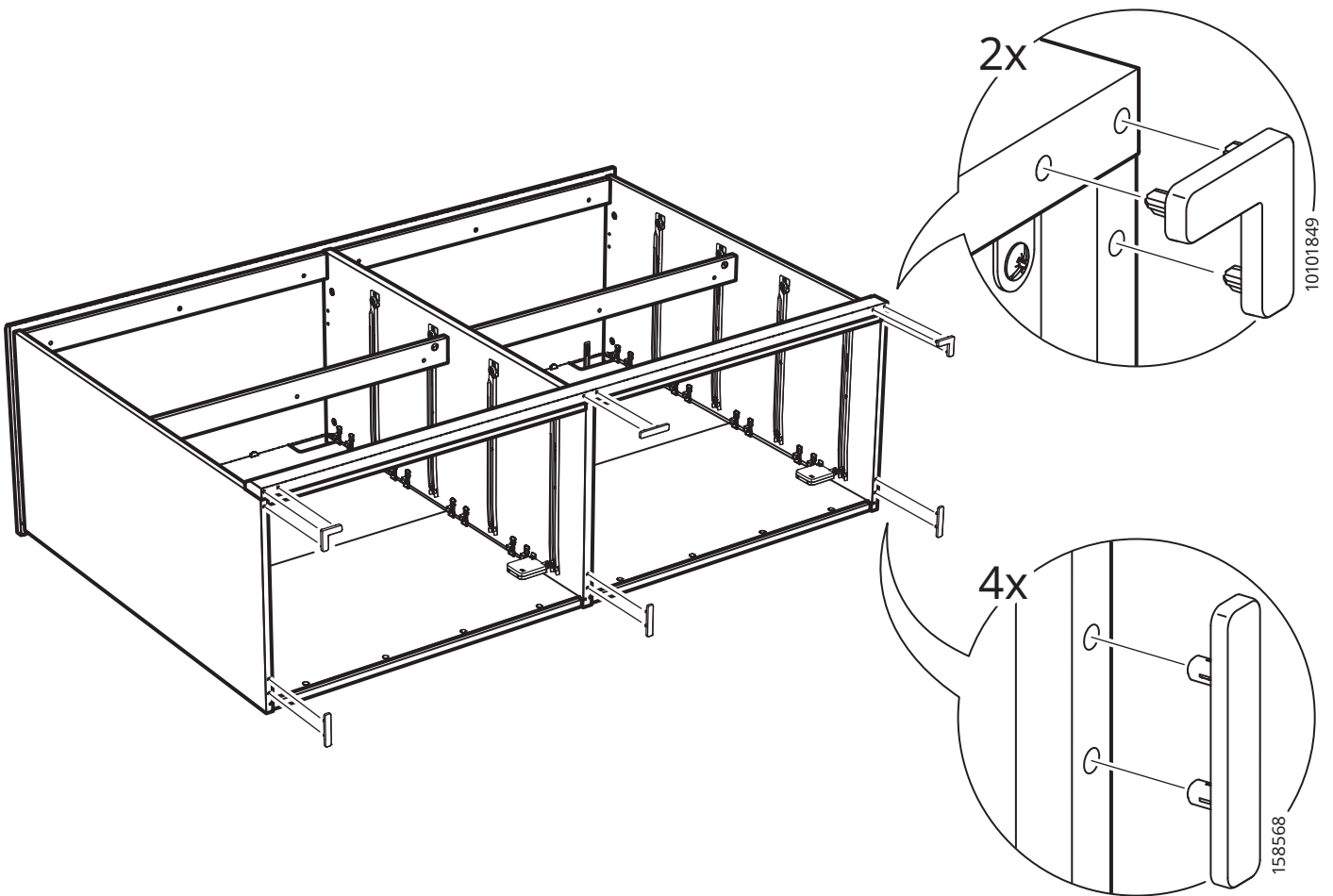

30

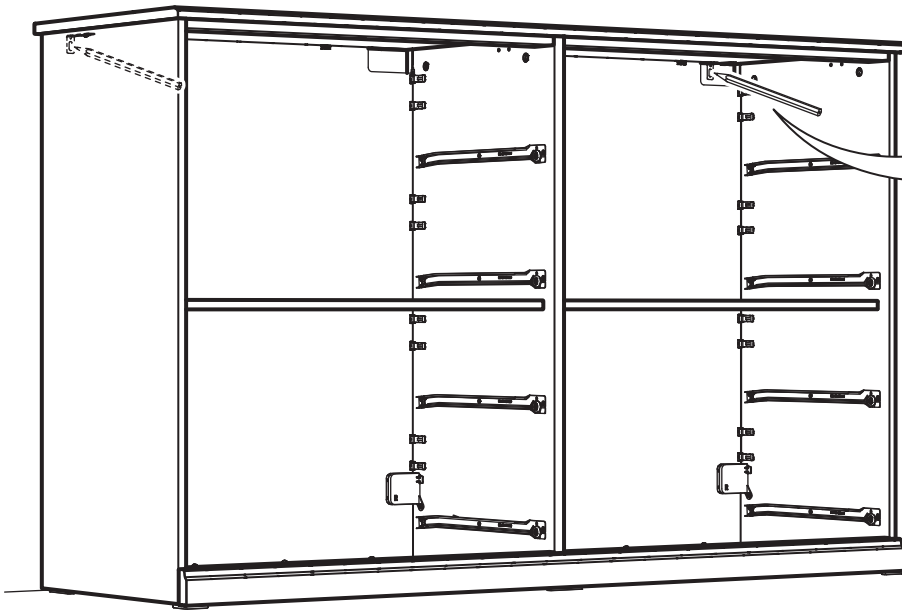

2x

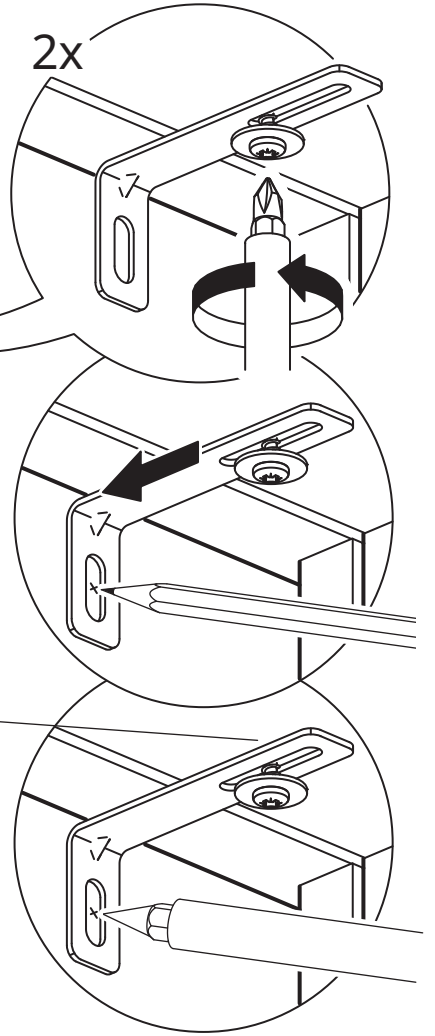

31

x

x

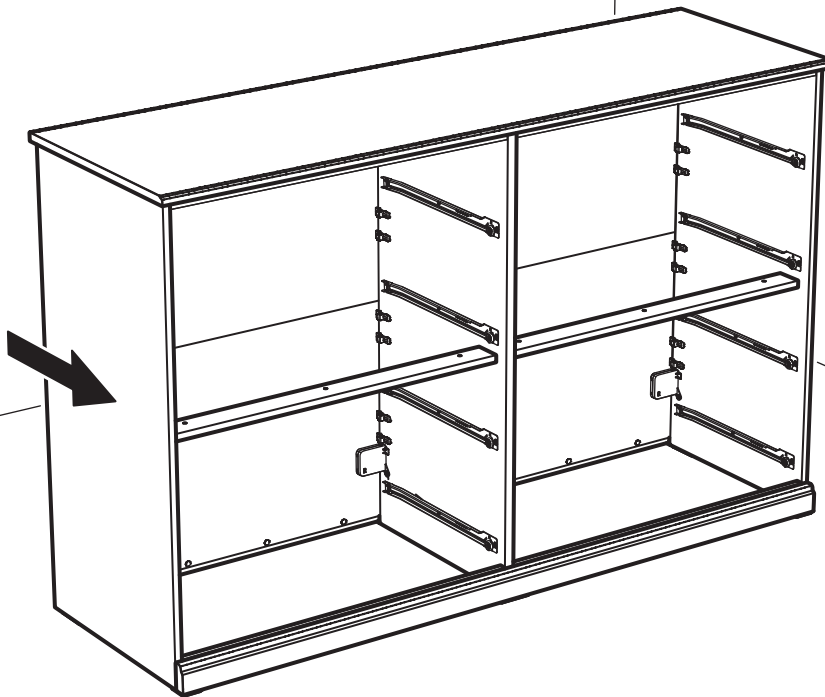



www.IKEA.com/secure-it

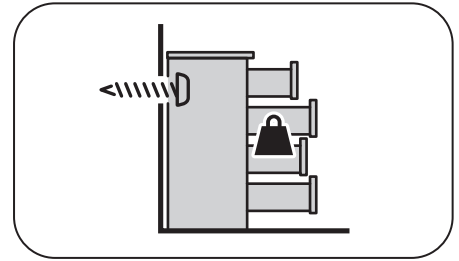

32

English

The screw(s) and plug(s) supplied can be used with most solid (A) and hollow (B) walls. For solid wood (C) use the screw(s) without plug(s). If you are uncertain, seek professional advice.

Français

Les vis et les chevilles fournies peuvent être utilisées avec la plupart des murs pleins (A) ou des murs creux (B). Pour le bois massif (C), utiliser les vis sans les chevilles. En cas de doute, adressez-vous à un professionnel qualifié.

Español

Los tornillos y tacos incluidos se pueden utilizar en la mayor parte de las paredes sólidas (A) o huecas (B). Para la madera maciza (C), usa los tornillos sin tacos. Si tienes dudas, acude a un experto.

A

Ø 5/16" (8 mm)

1

2 3/4" (70 mm)

2

25

B

Ø 5/16" (8 mm)

1

≈ 1 1/4" (≈ 30 mm)

2

26

C

Ø 1/8" (3 mm)

1

≈ 1 1/4" (≈ 30 mm)

29

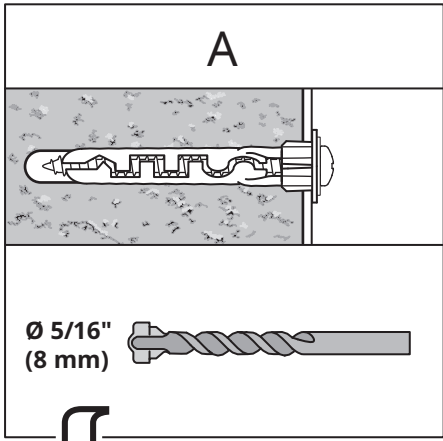

33

x

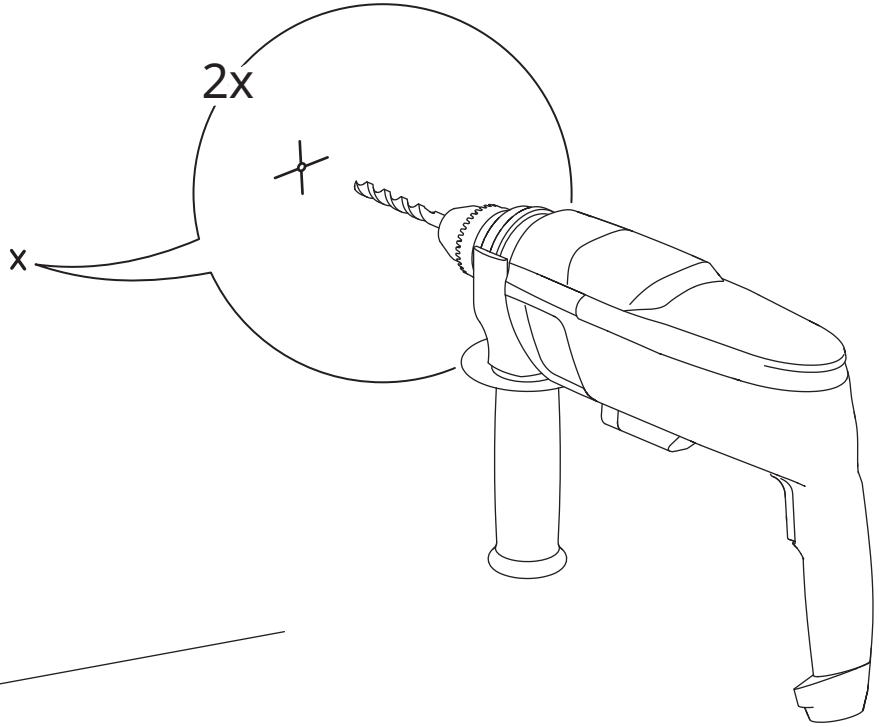

34

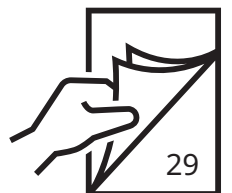
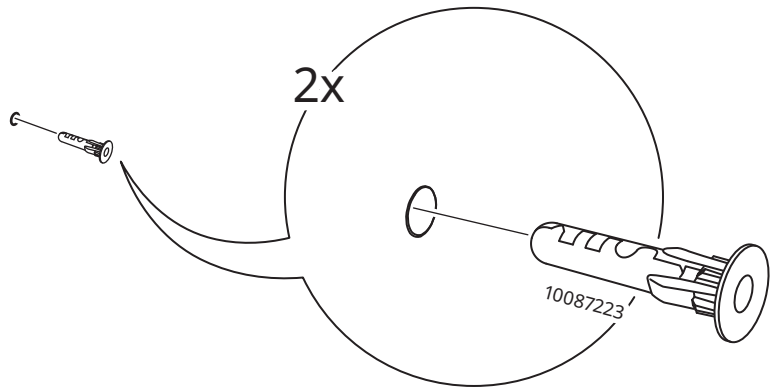

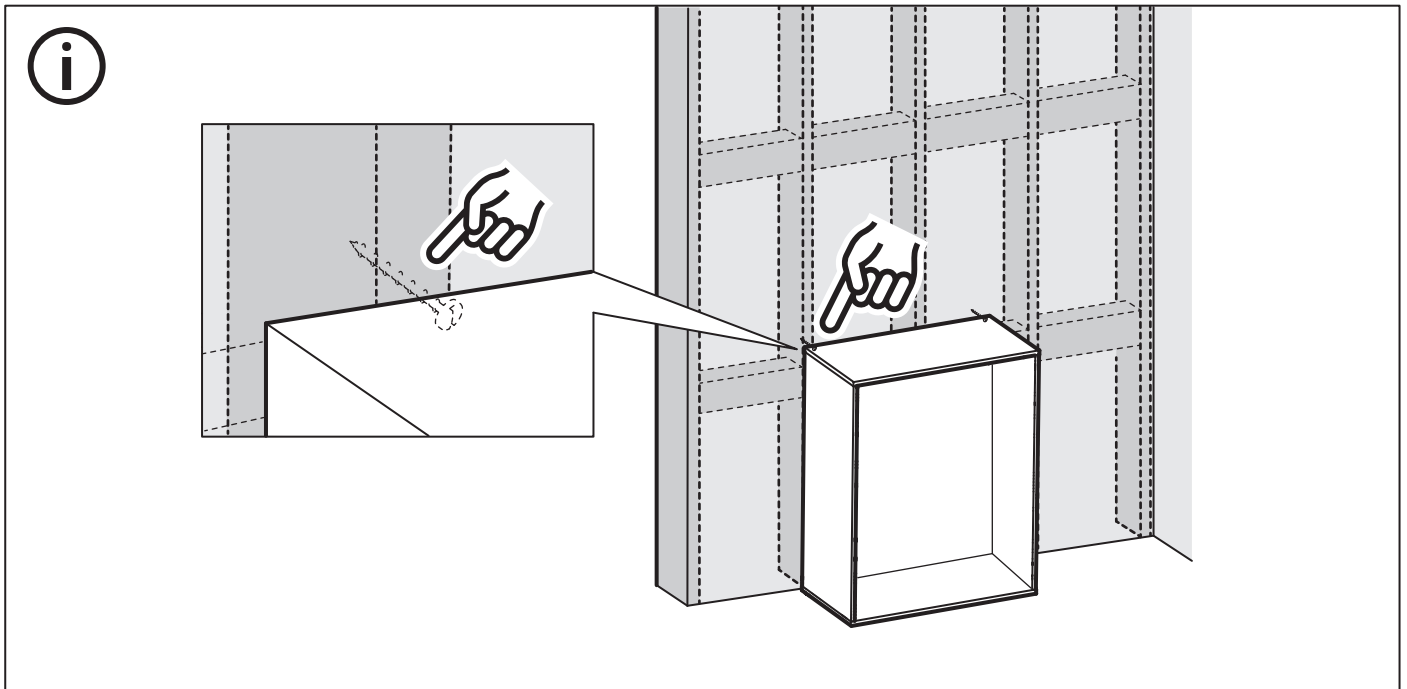
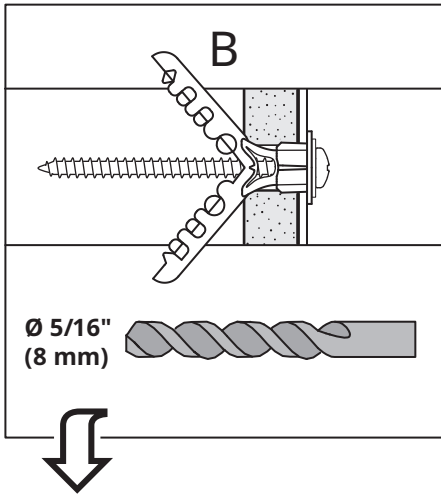

33

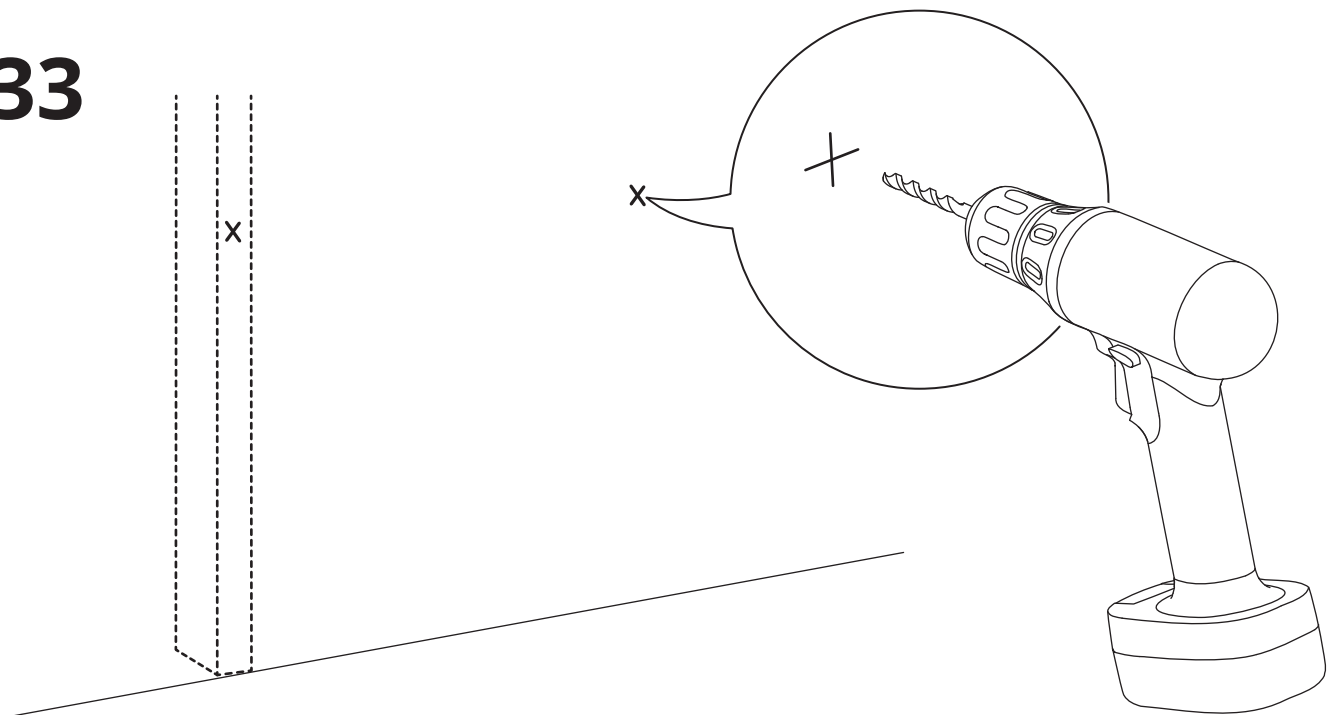

34

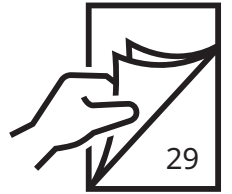
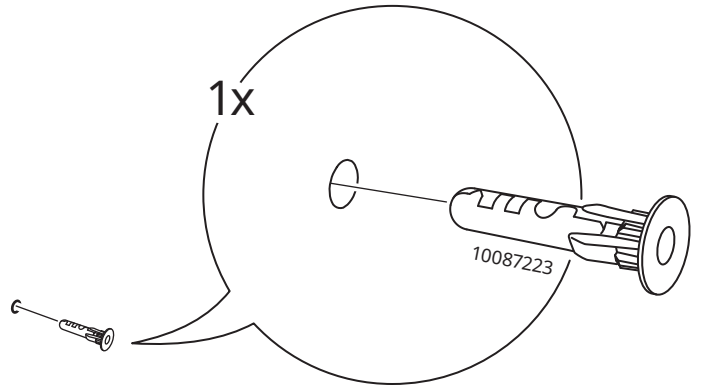
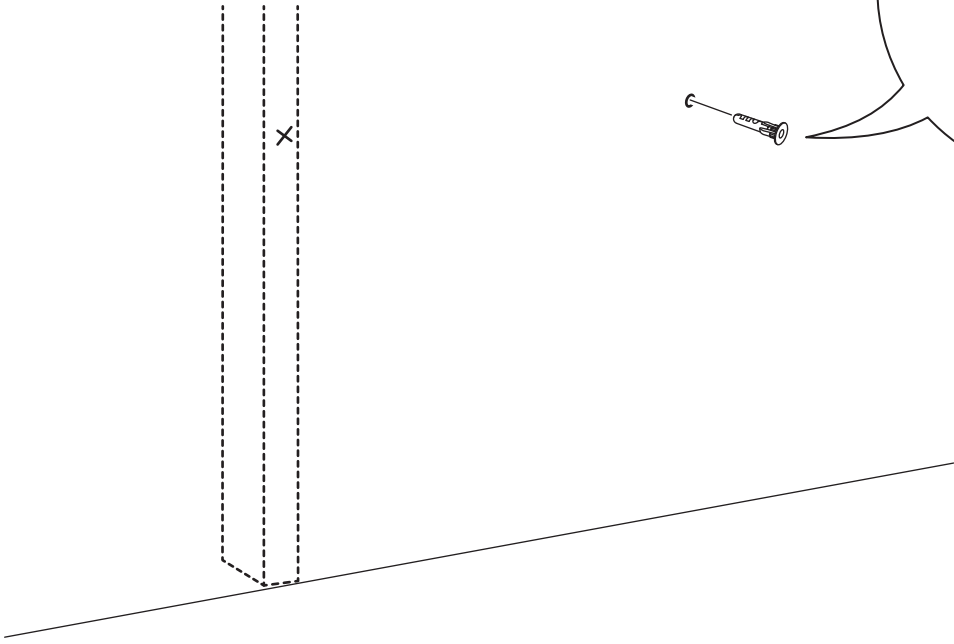

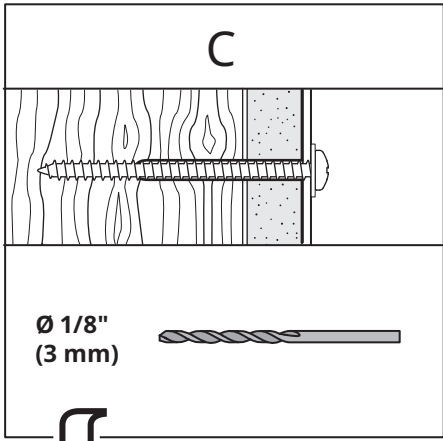

33

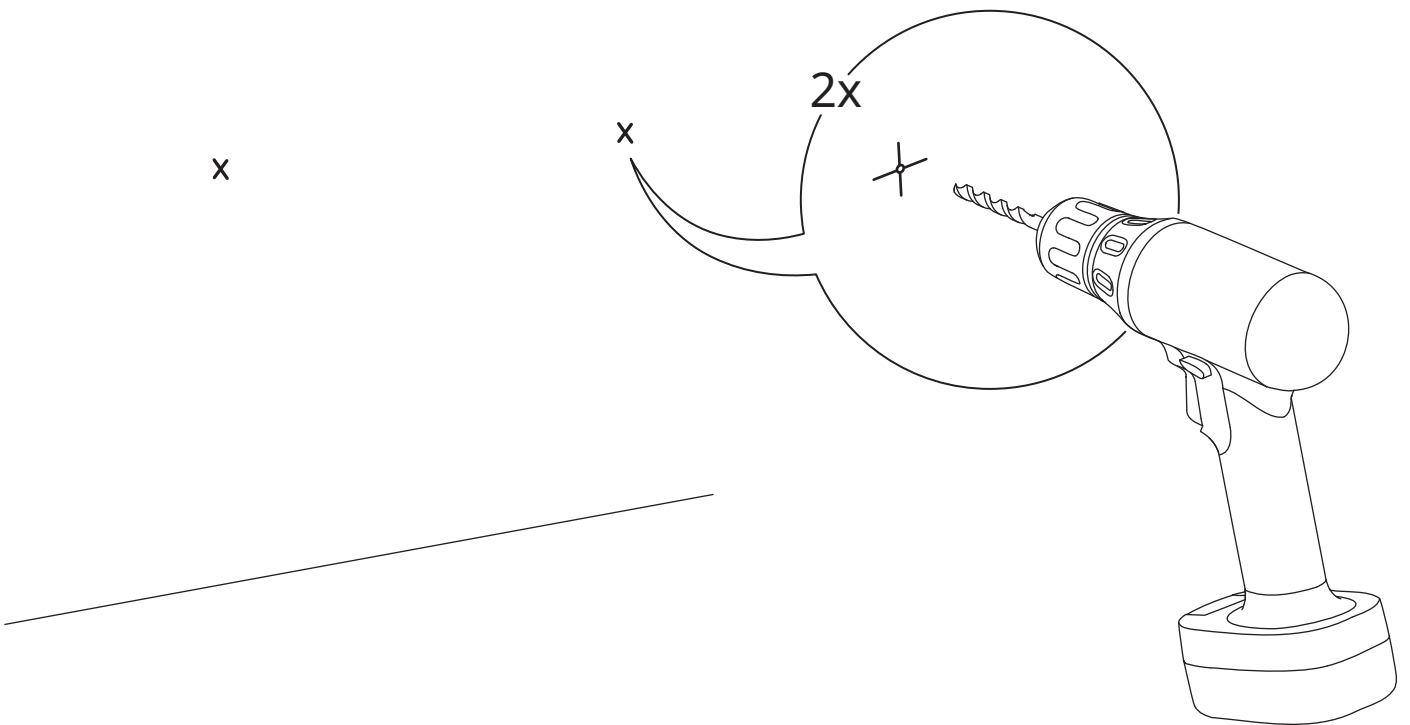

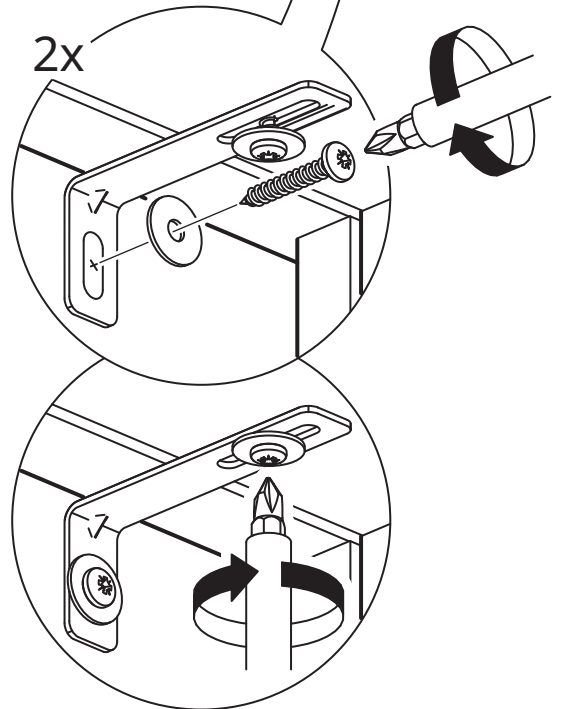
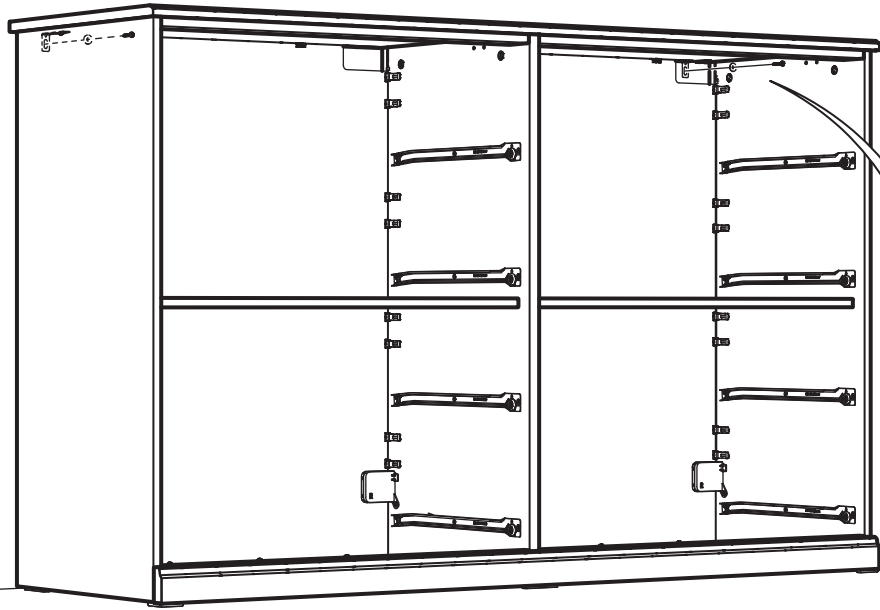

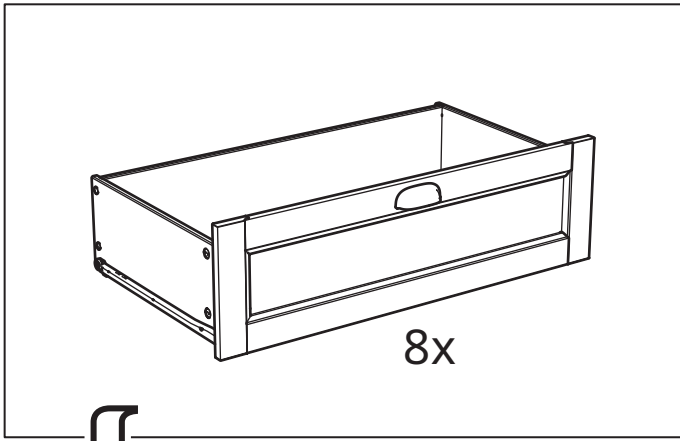

36

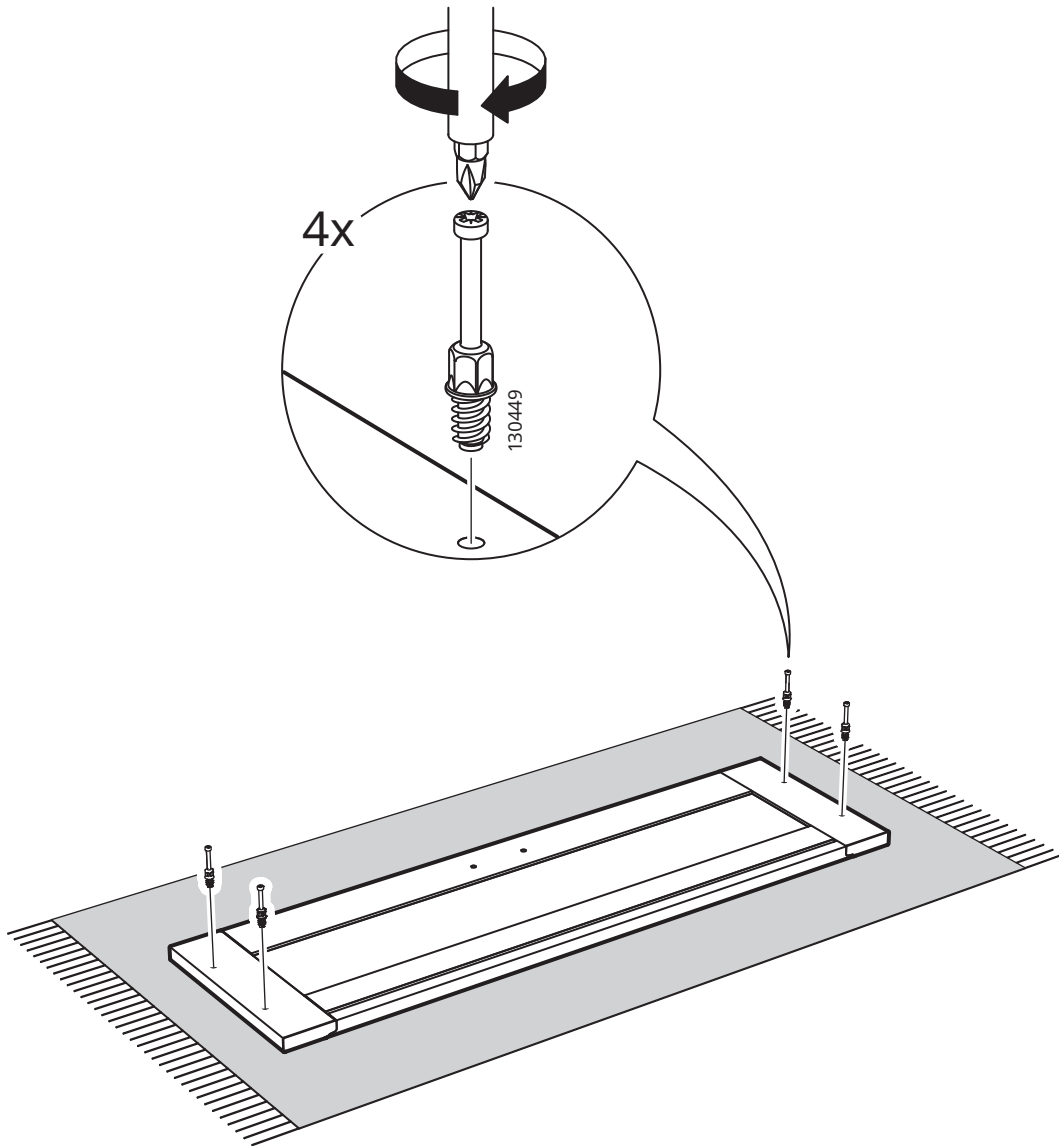

37

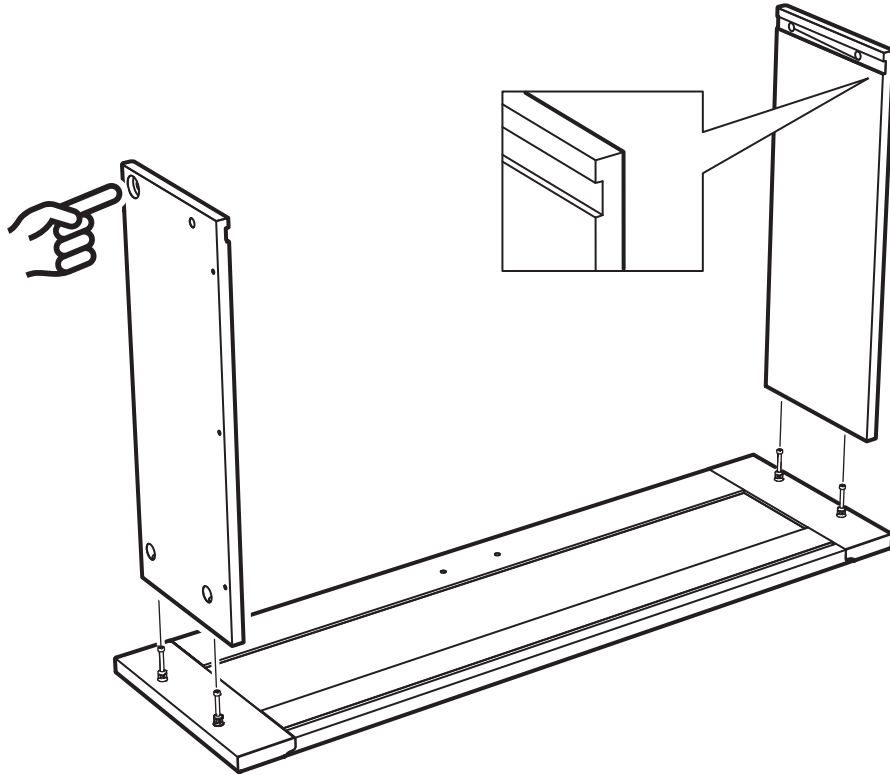

38

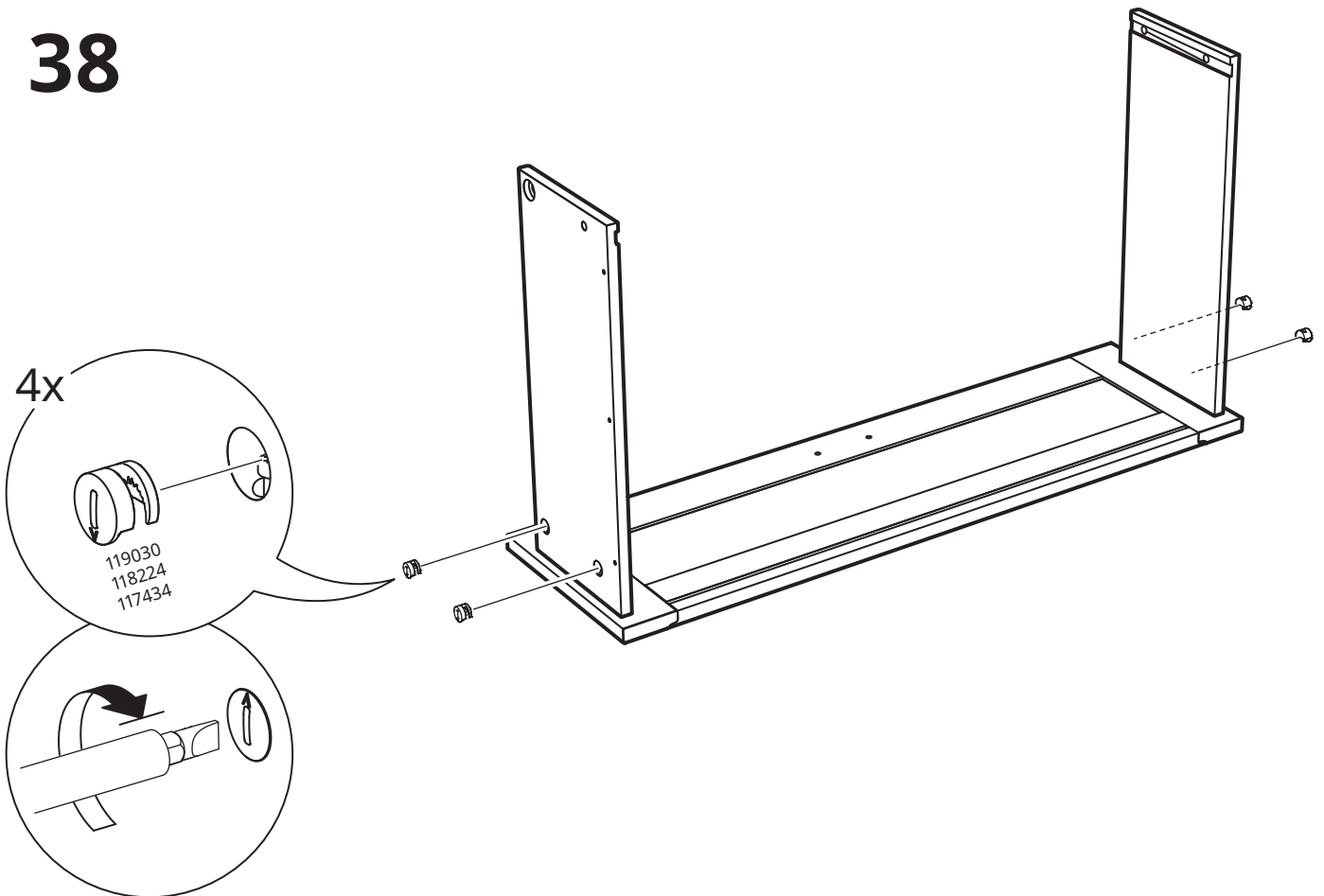

39

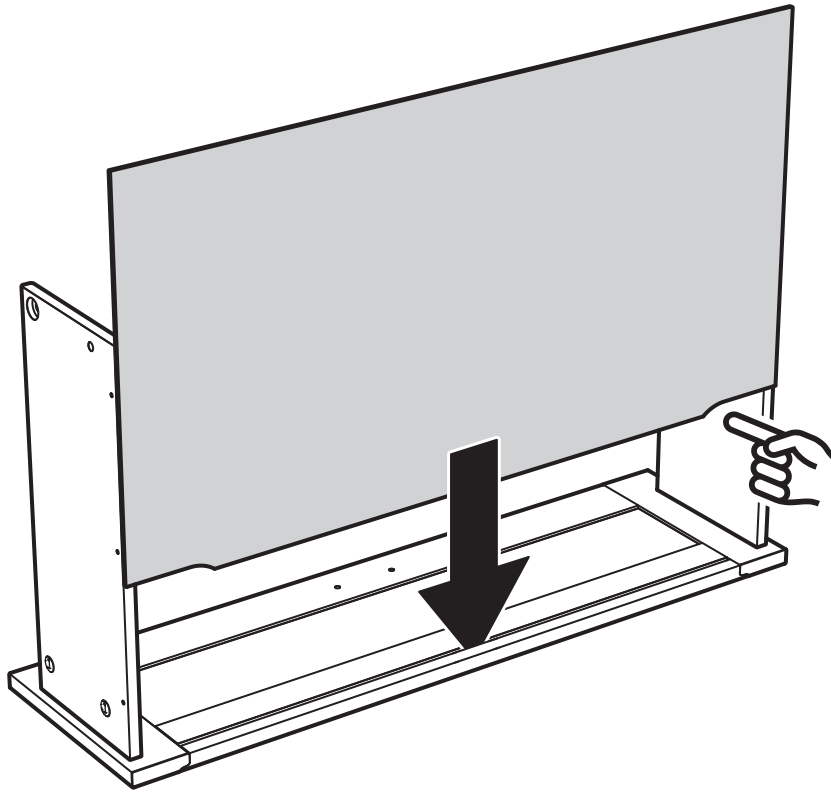

40

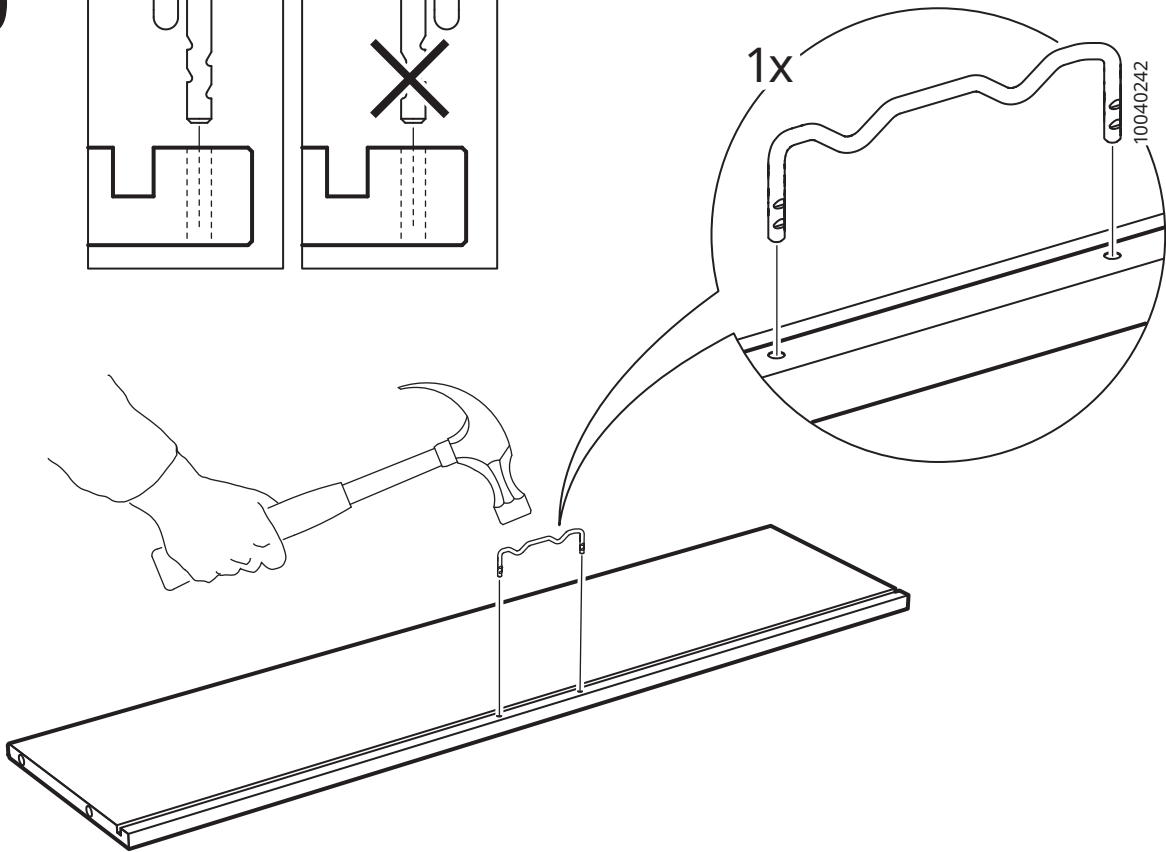
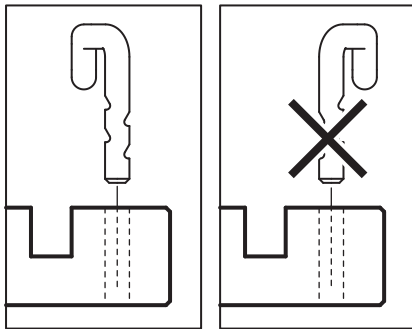

41

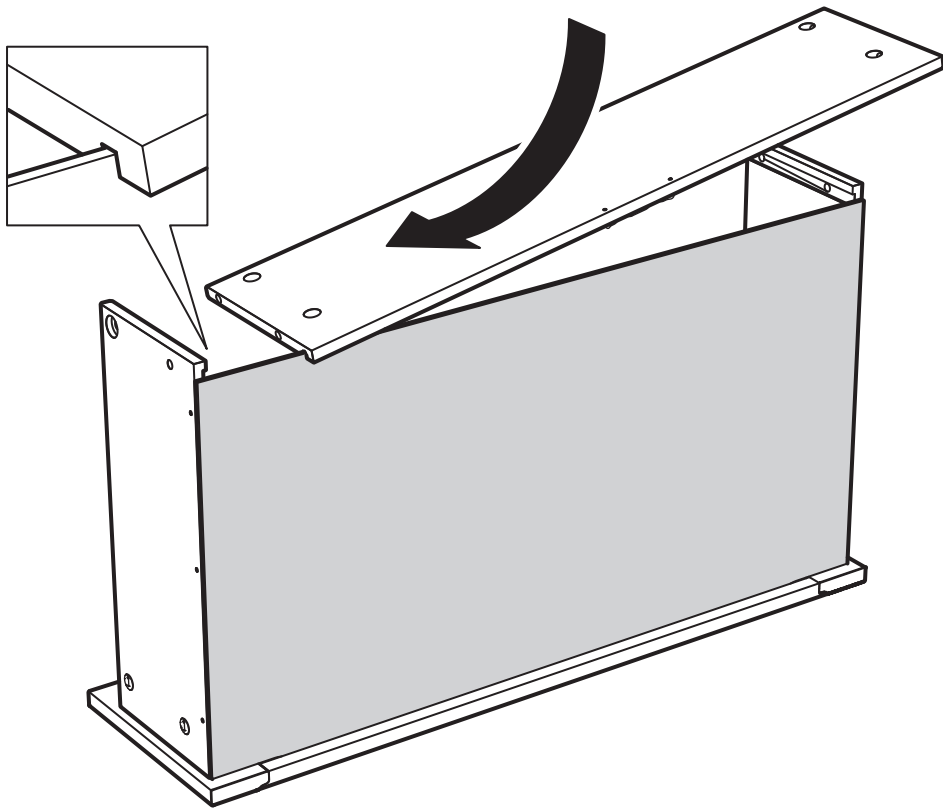

42

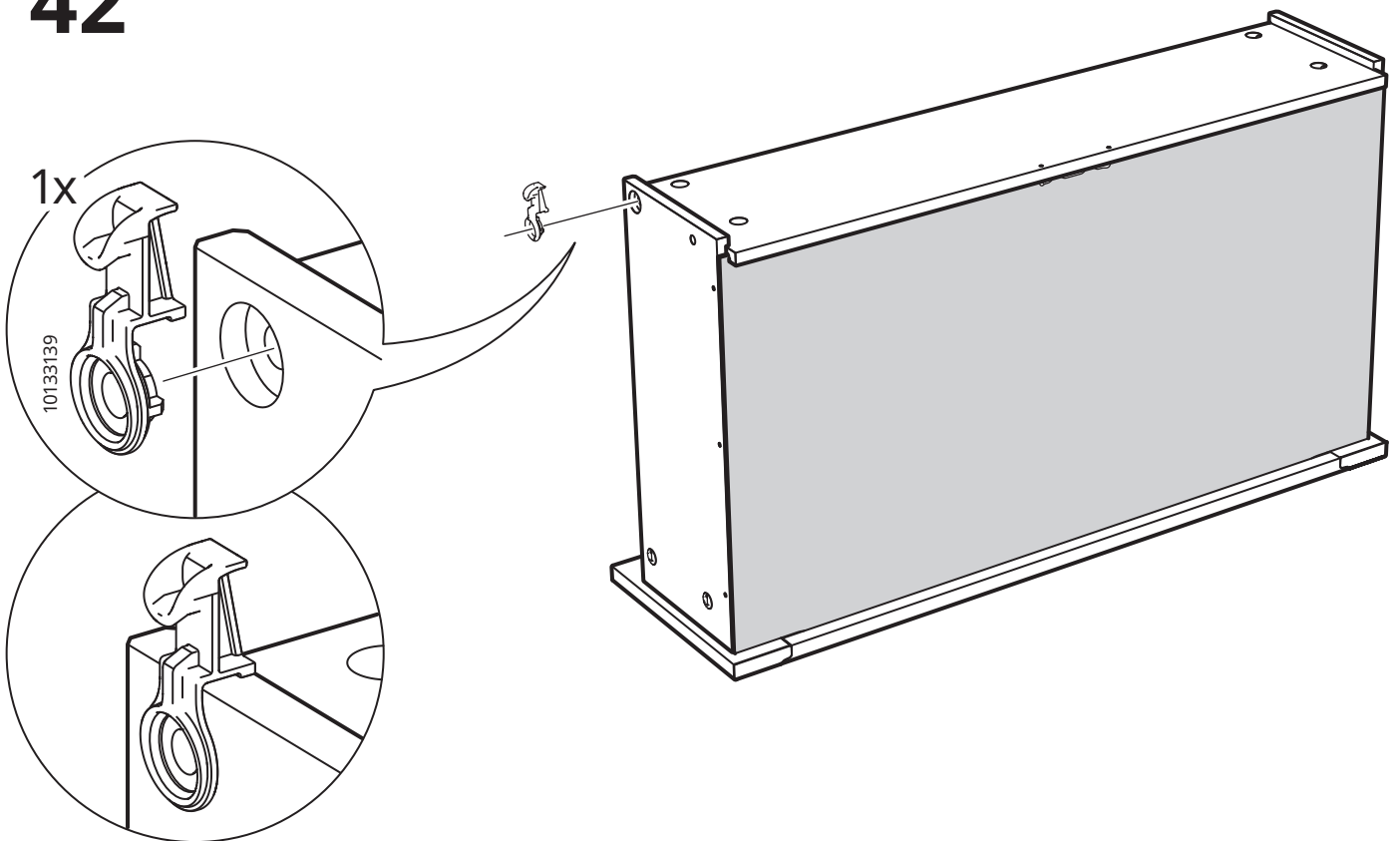

43

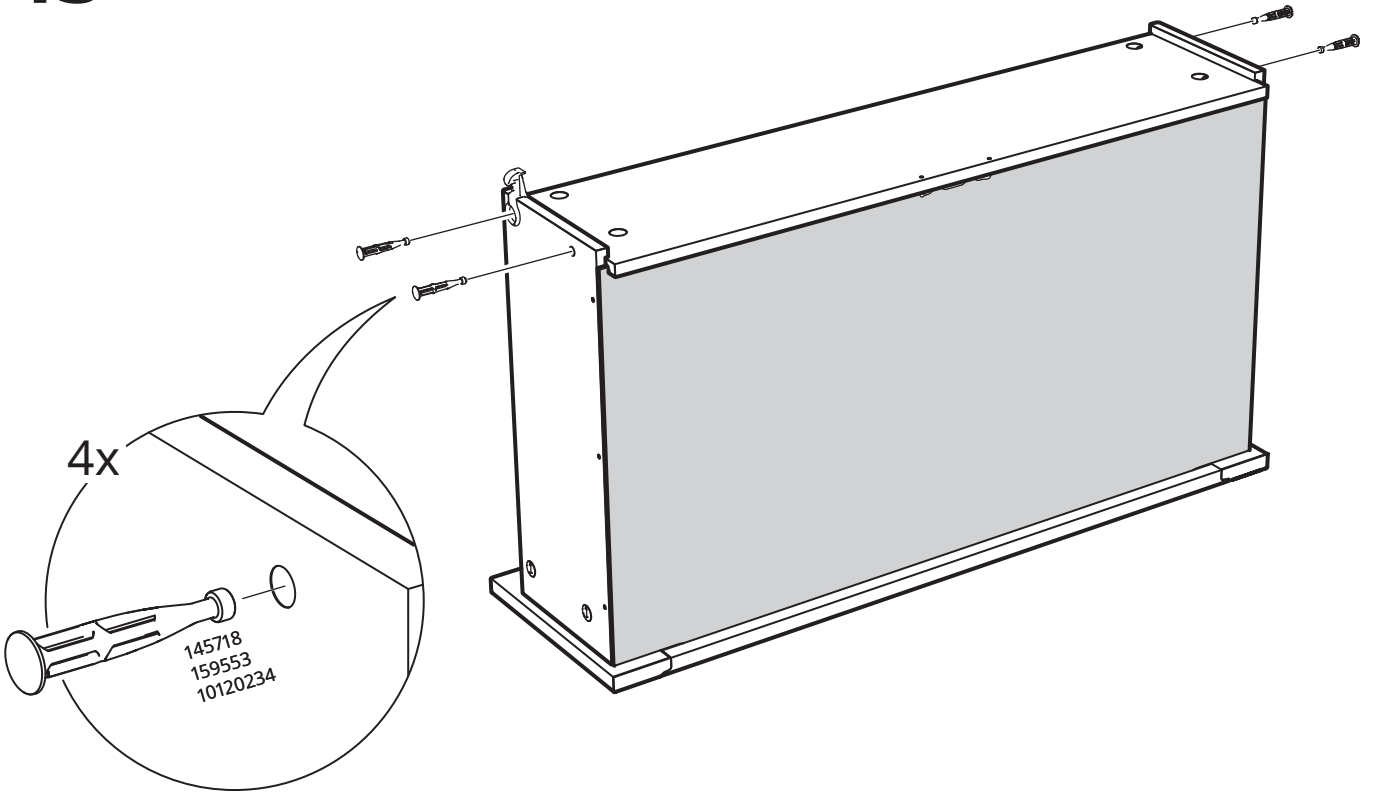

44

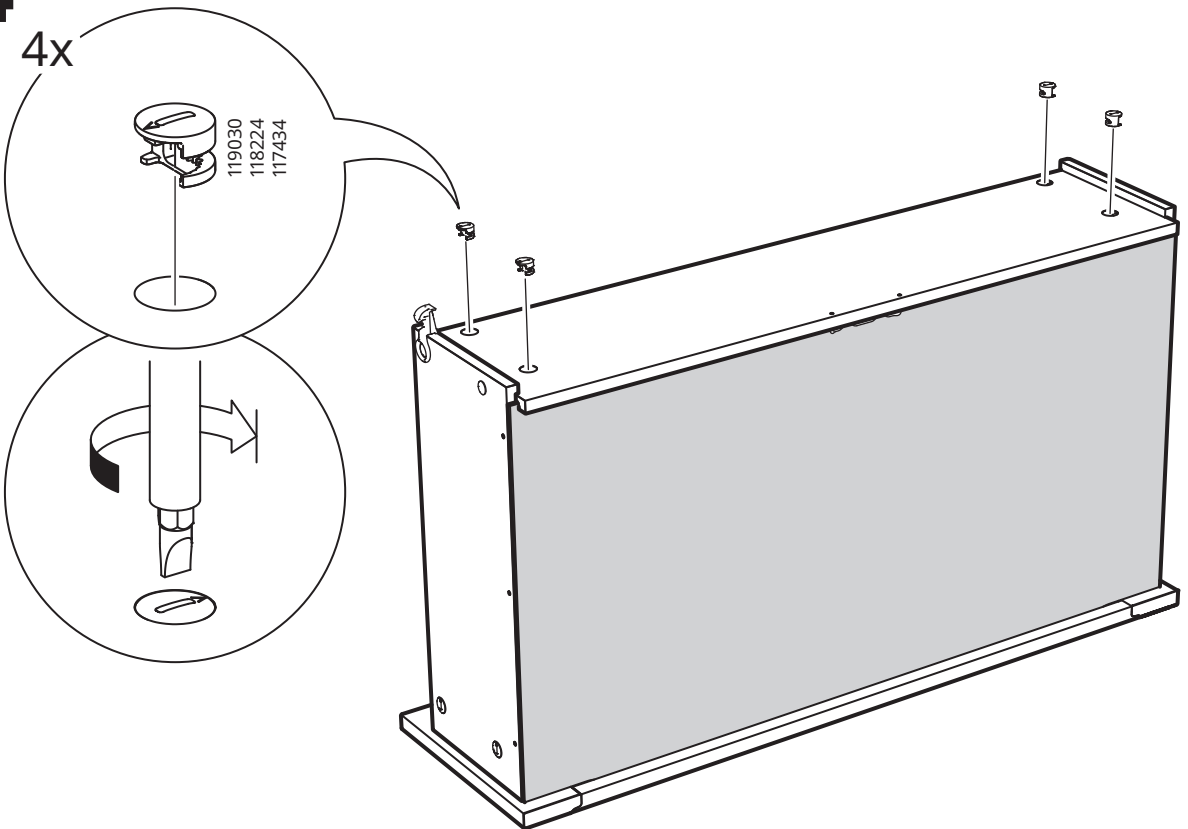

45

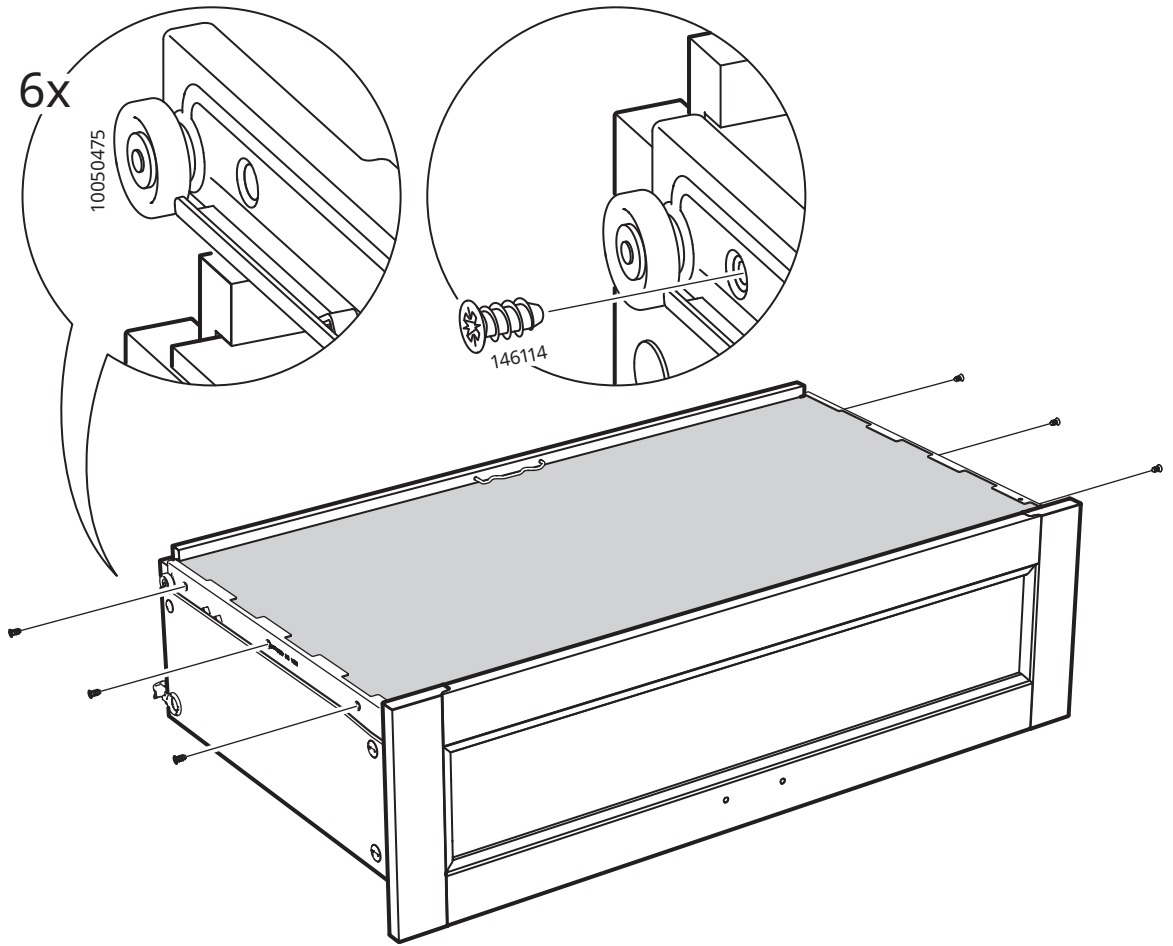

46

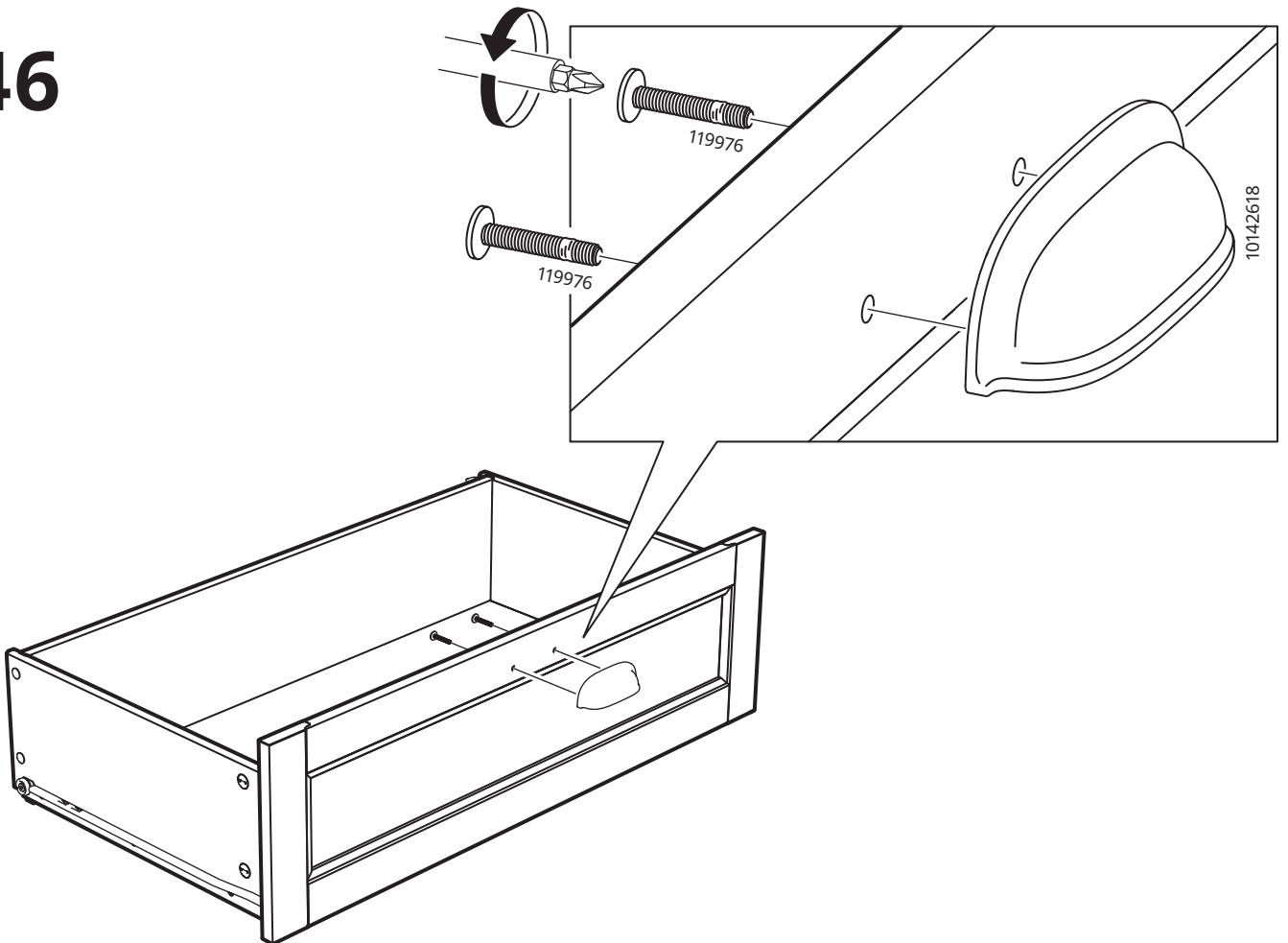

47

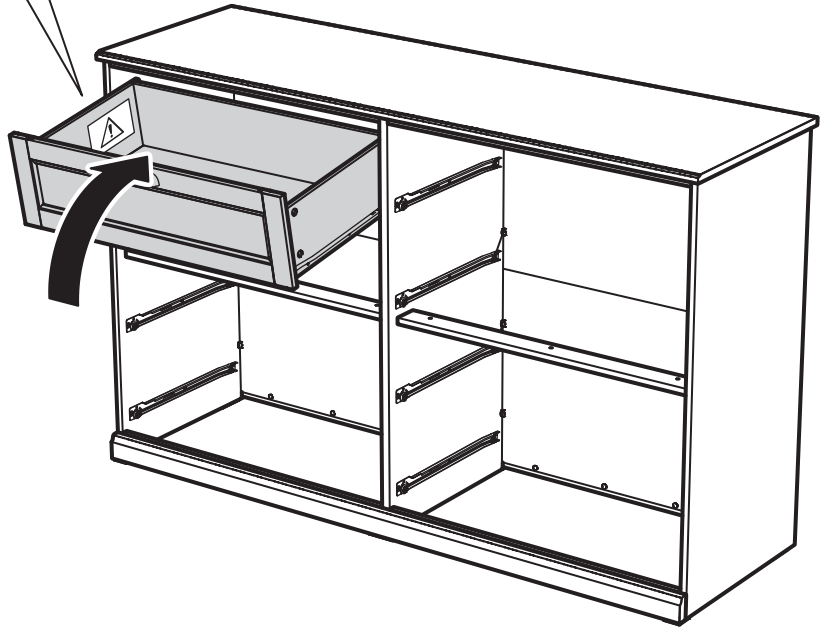
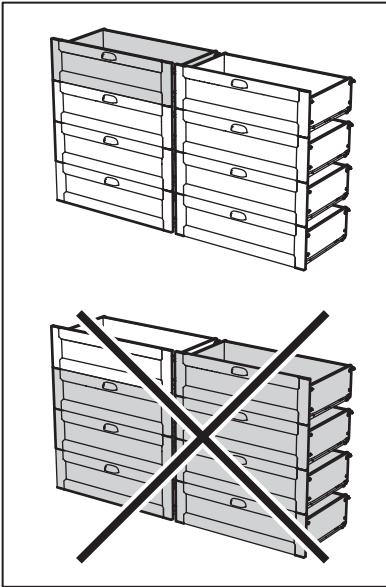

48

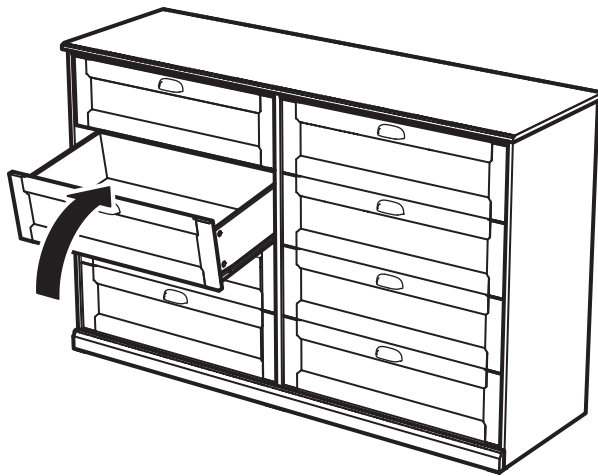

1

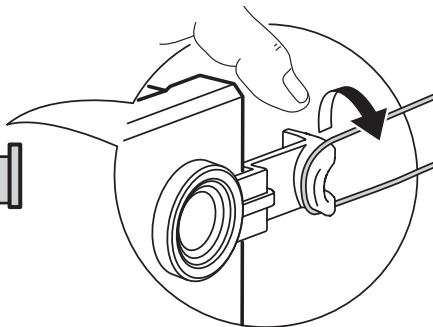
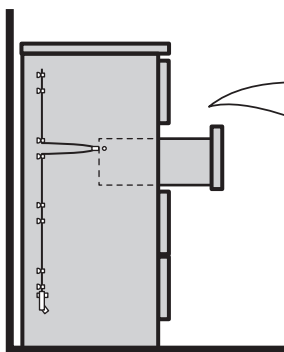

2

