

SALLSJÖN

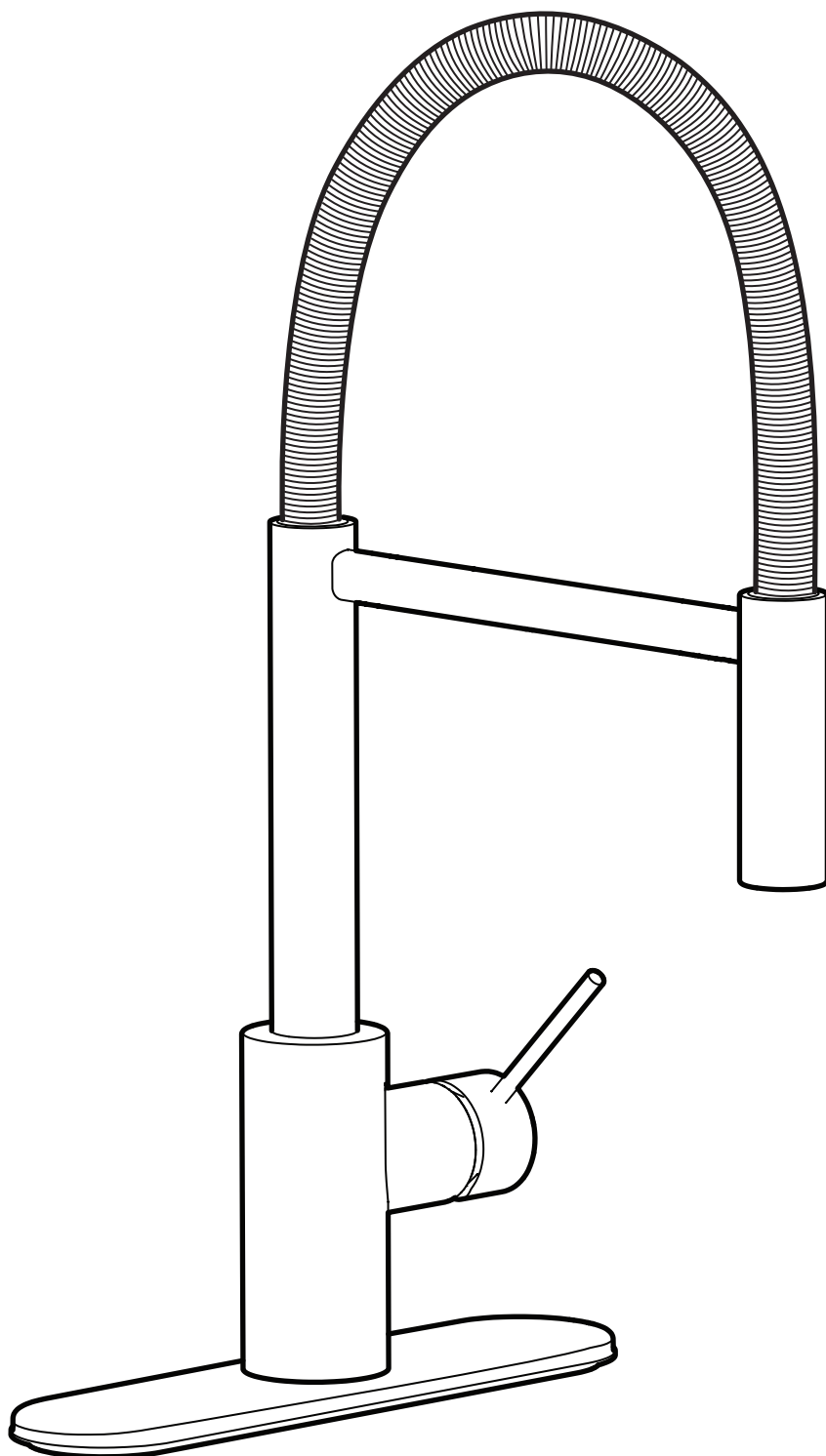

Design and Quality
IKEA of Sweden

**English**

Installation must be performed in compliance with current local construction and plumbing regulations. If in doubt, contact a professional.

Français

L'installation doit être réalisée en conformité avec les normes actuelles relatives à la construction et à la plomberie. En cas de doute, contacter un professionnel.

Español

La instalación debe realizarse siguiendo las normativas actuales sobre construcción y fontanería. En caso de duda, ponte en contacto con un profesional.

**English**

Switch off main shut-off valve before changing mixer tap.

Français

Fermer le robinet central d'eau avant de changer le mitigeur.

Español

Cierra la llave de paso general antes de cambiar el grifo.

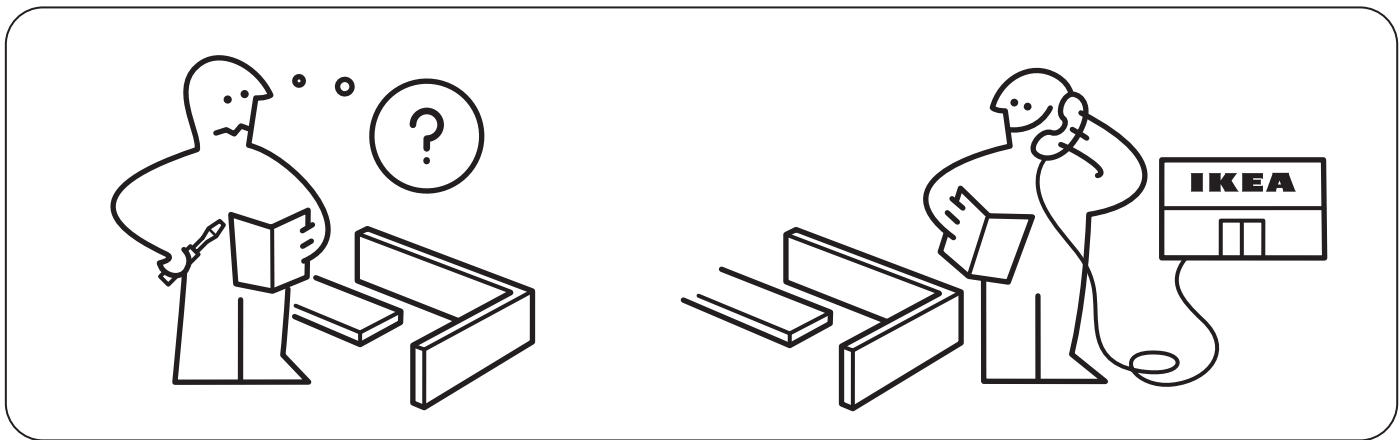
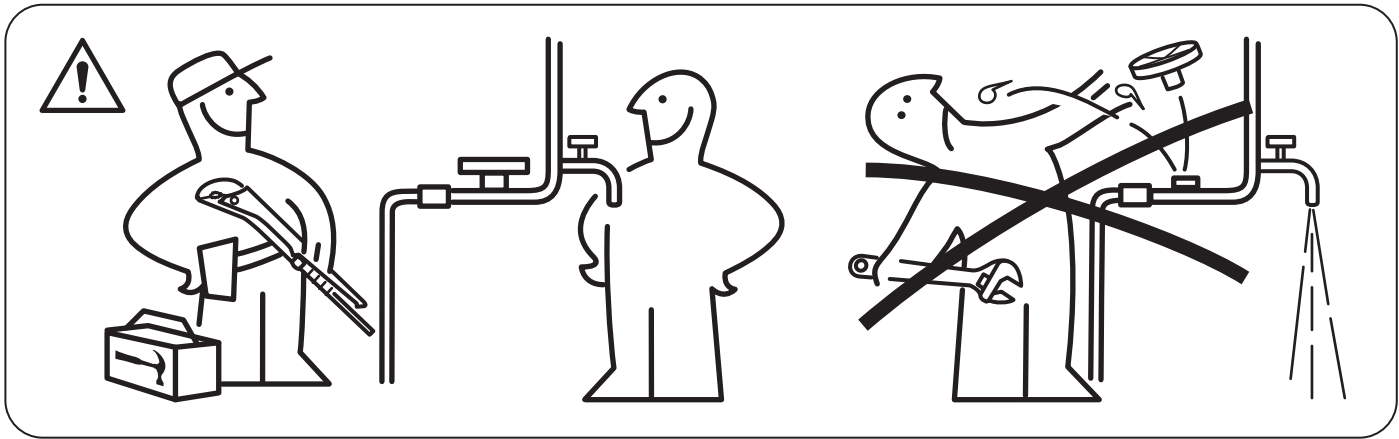
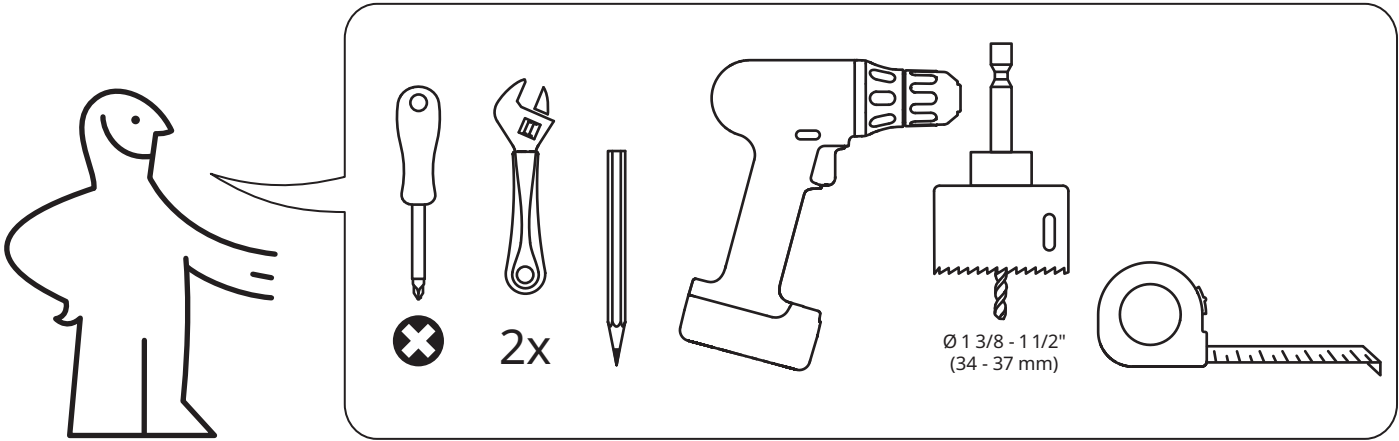

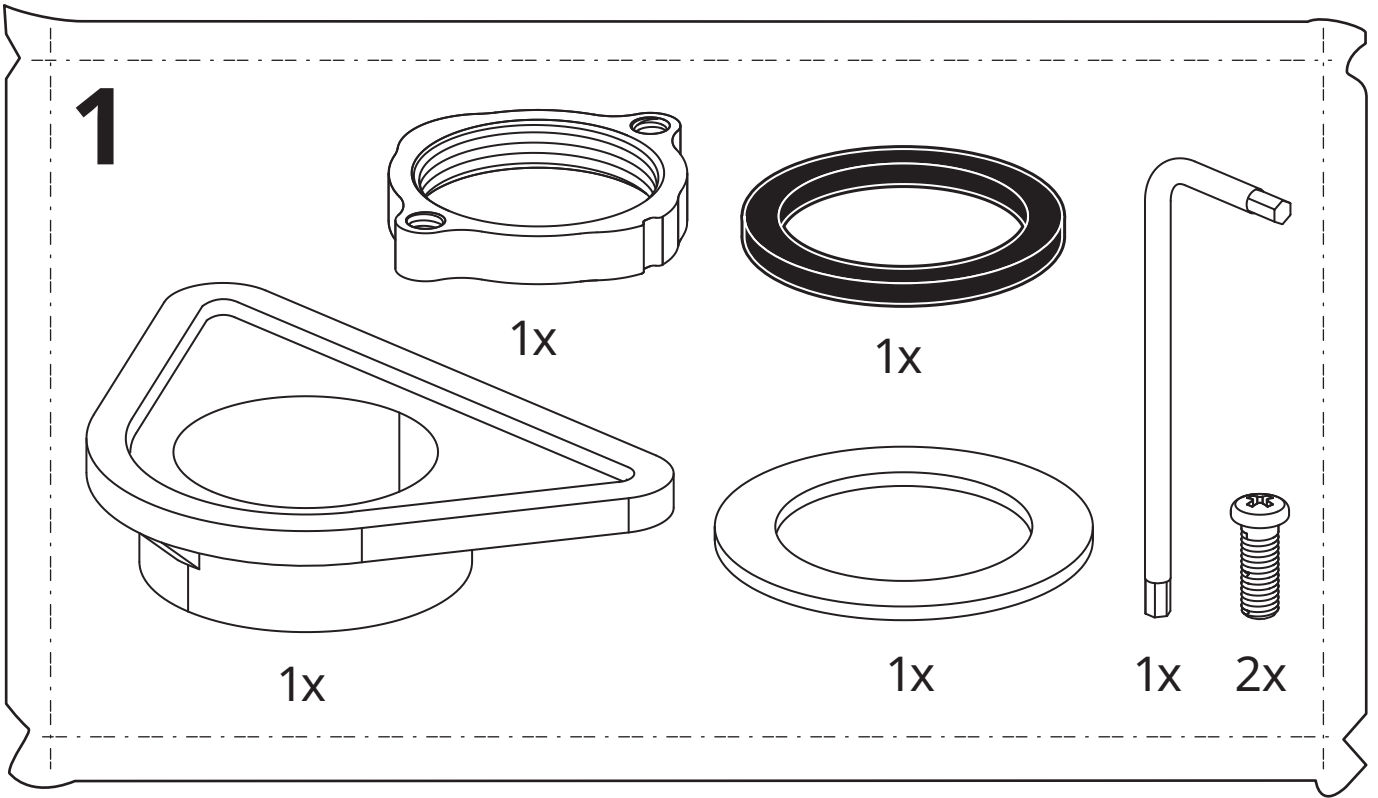

10140225

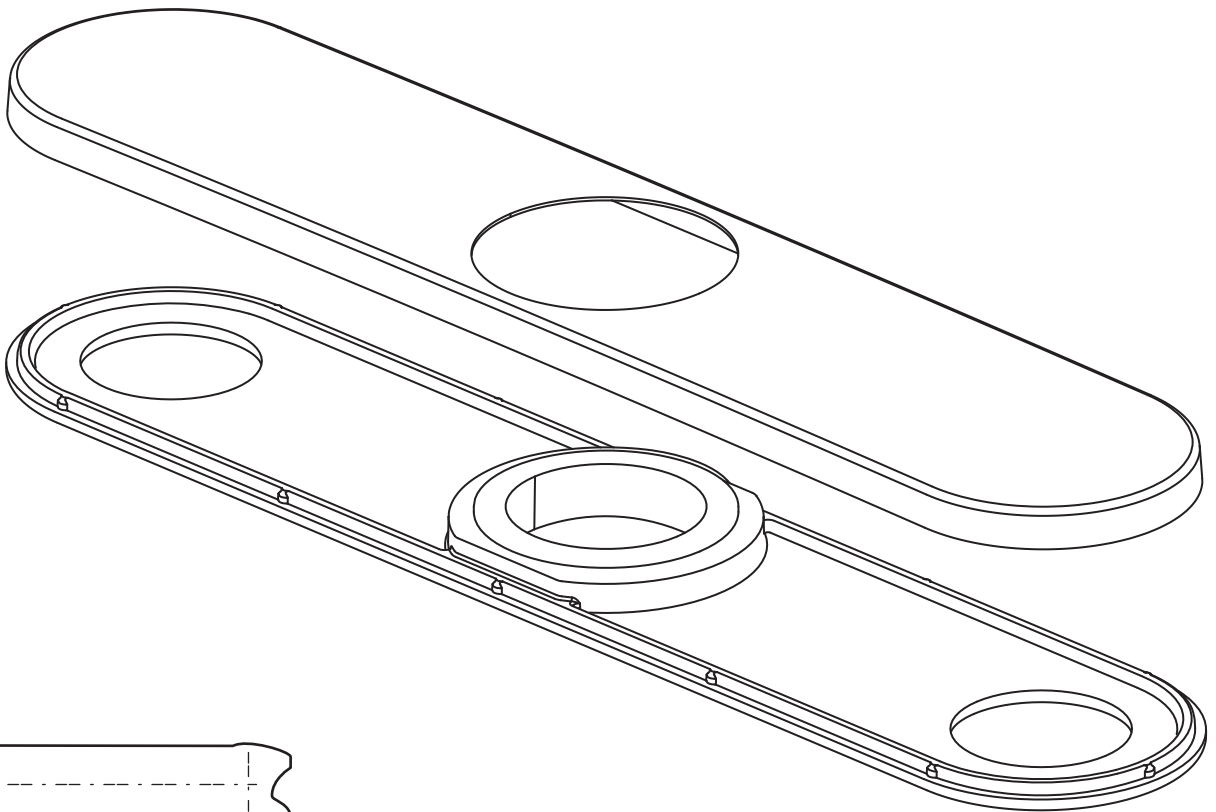

10140178
10142518

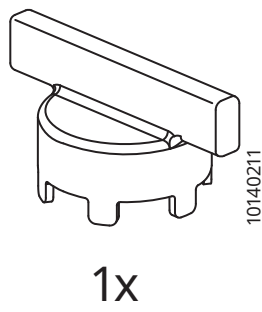
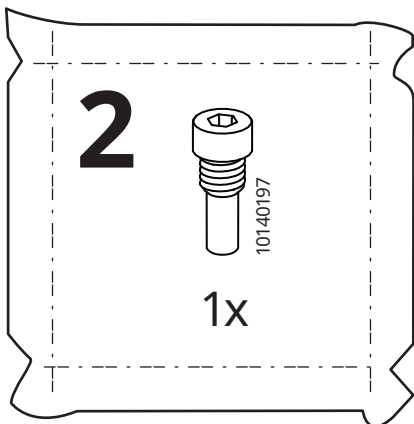

1x

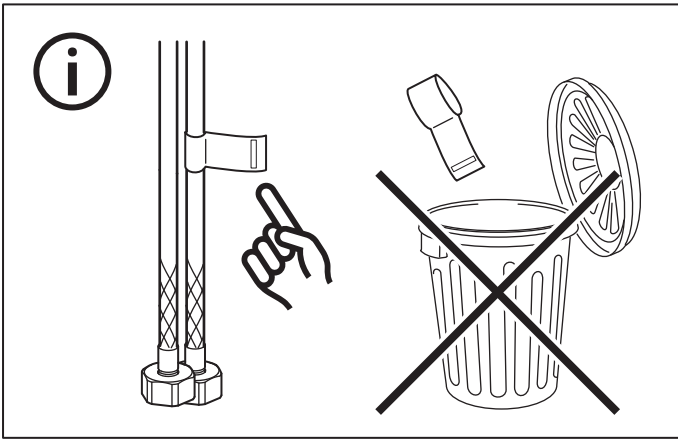

140°F
60°C
(Max. 176°F
Max. 80°C)

1,4 - 5 bar
20 - 72,5 psi
(1,4 - 10 bar
20 - 145 psi)

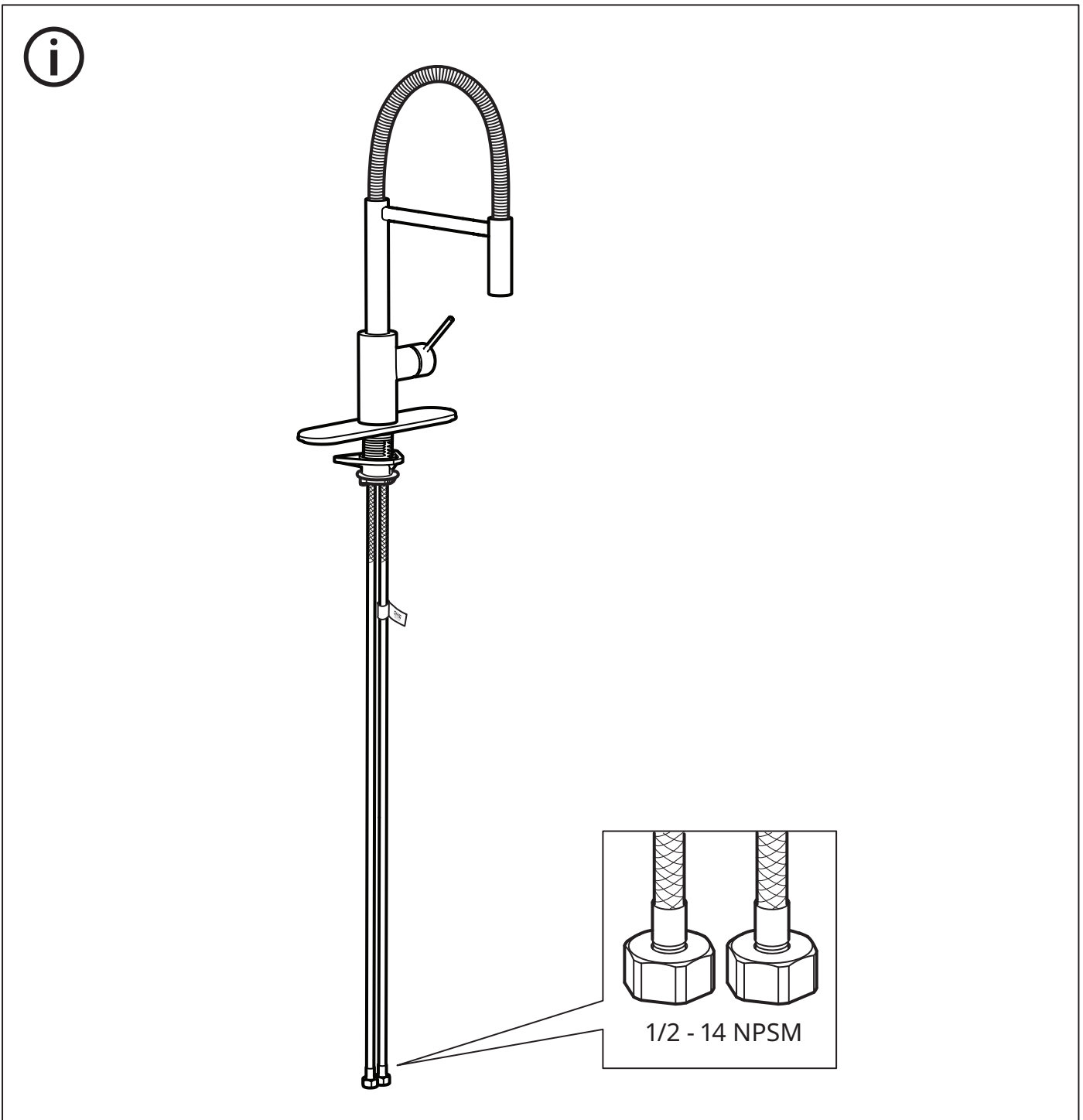

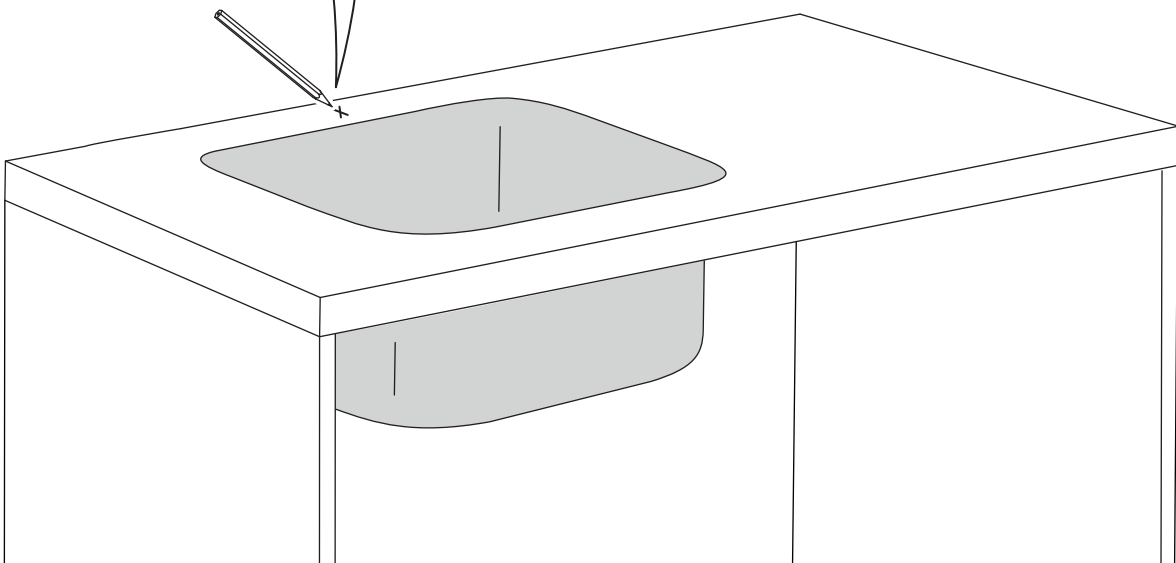
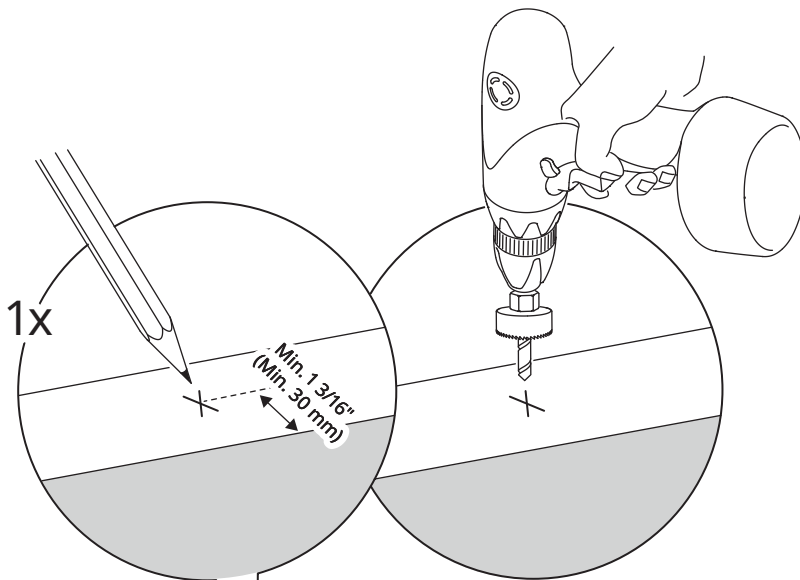
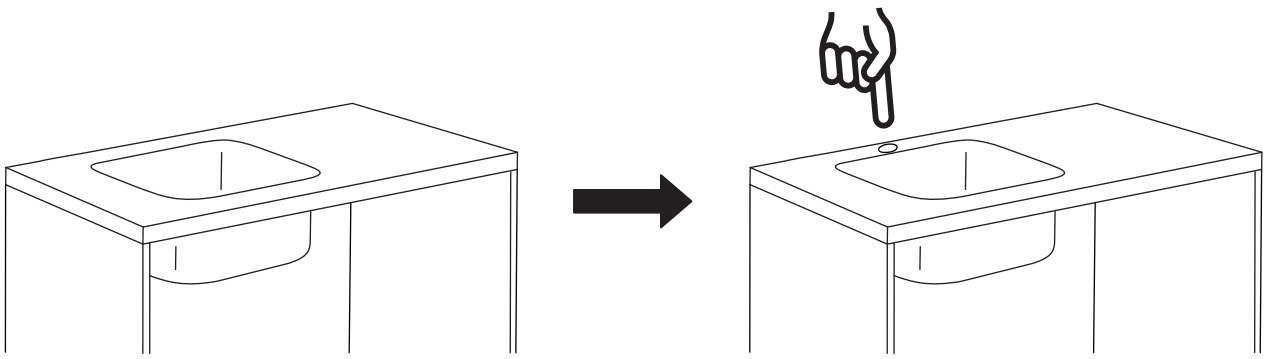

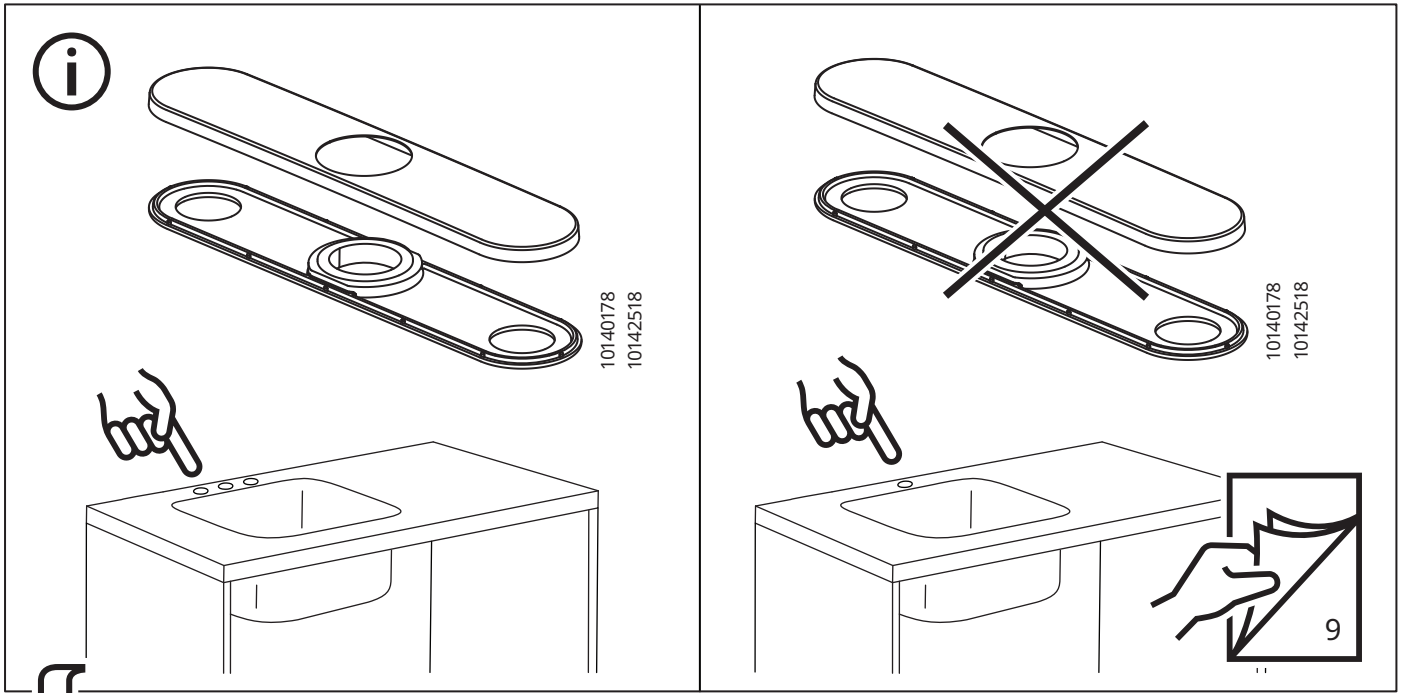

1

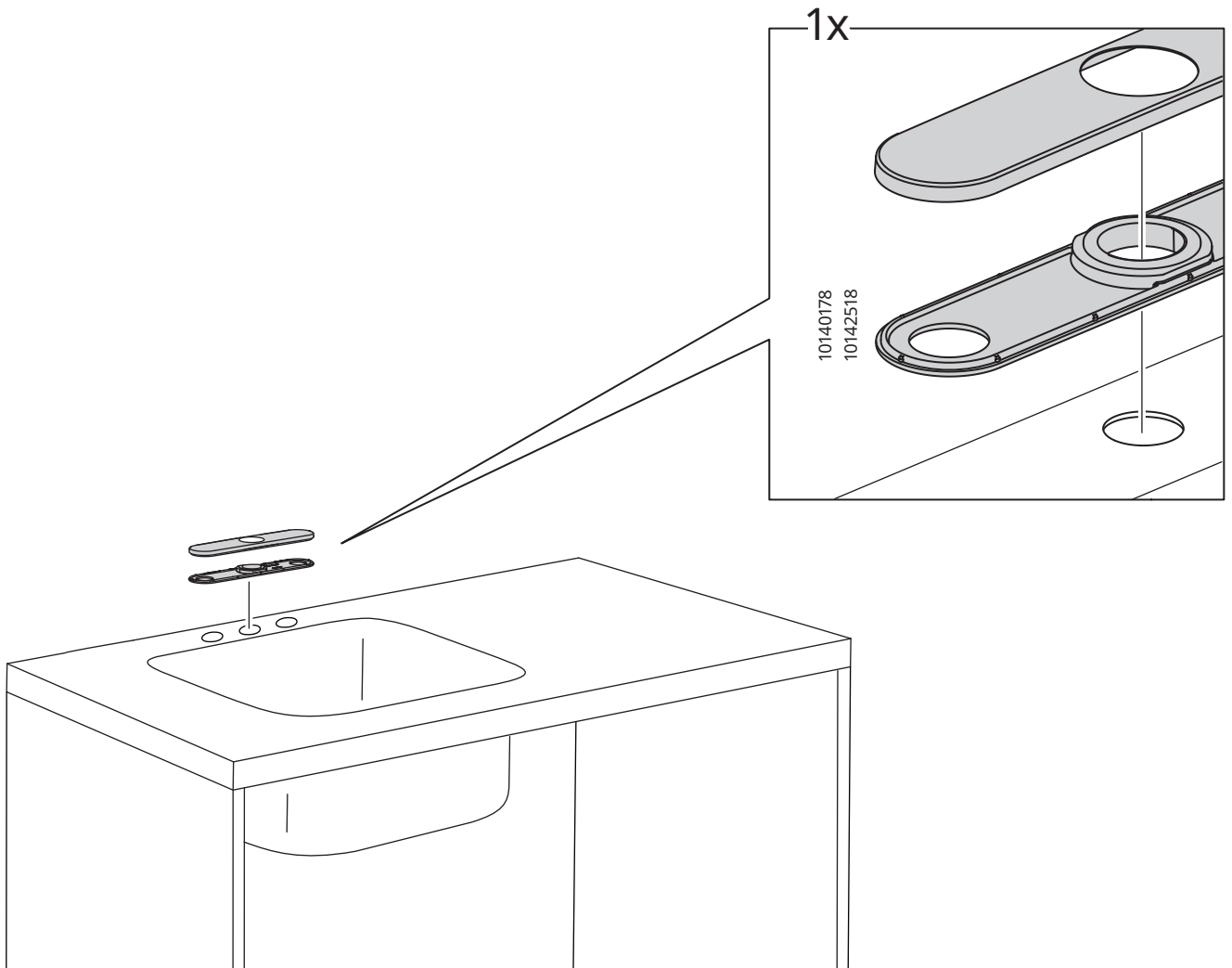

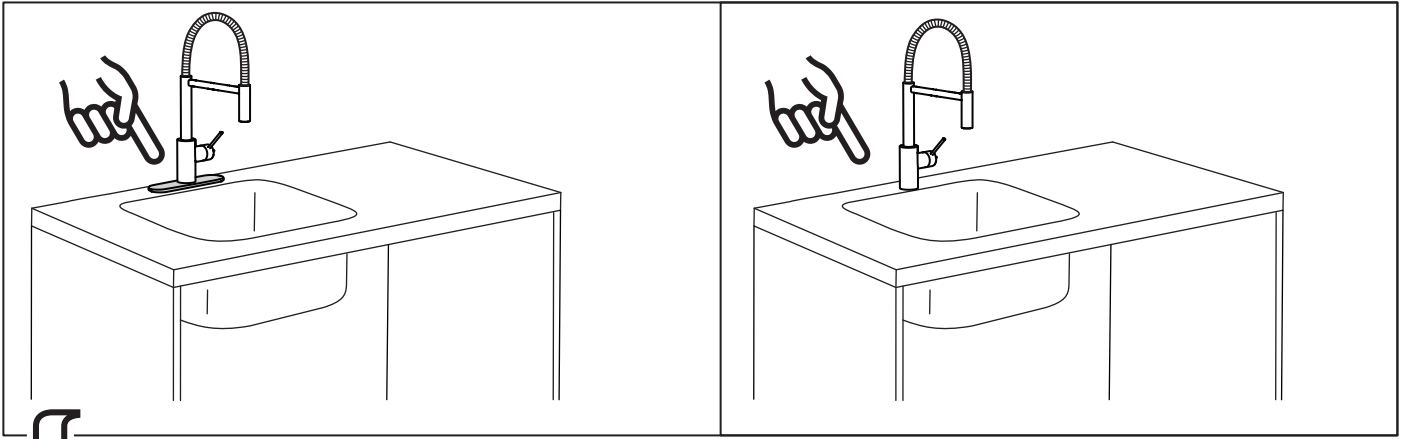

2

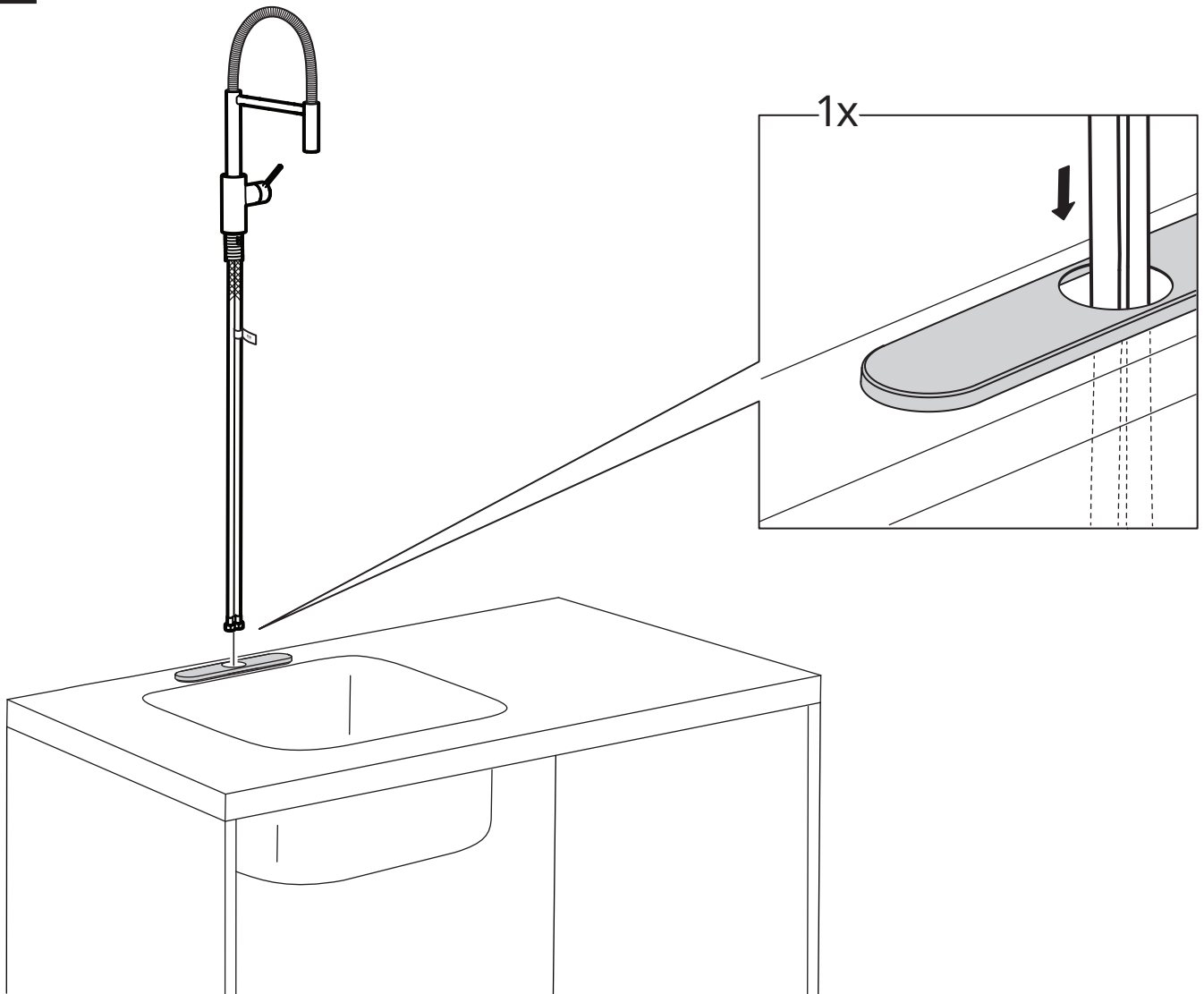

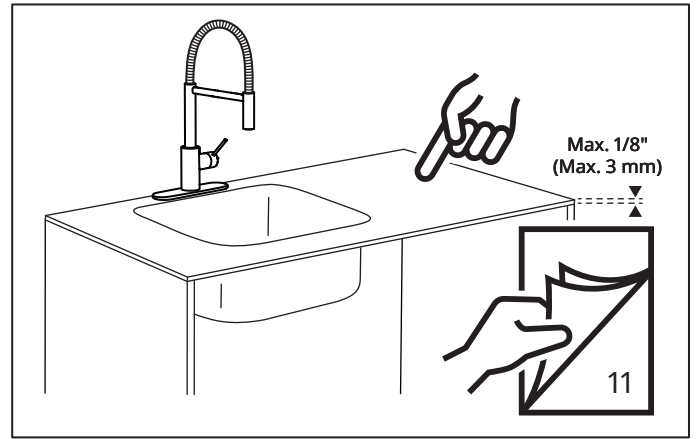
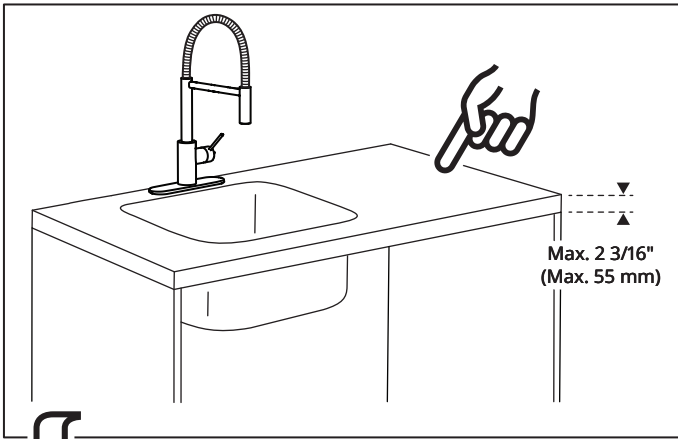

3

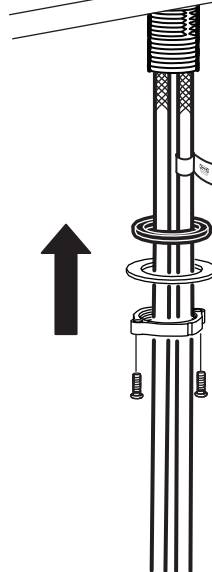
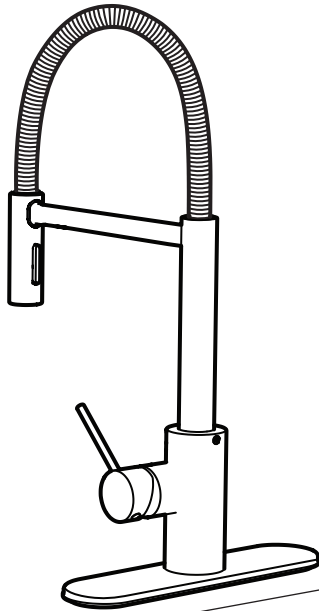

1x

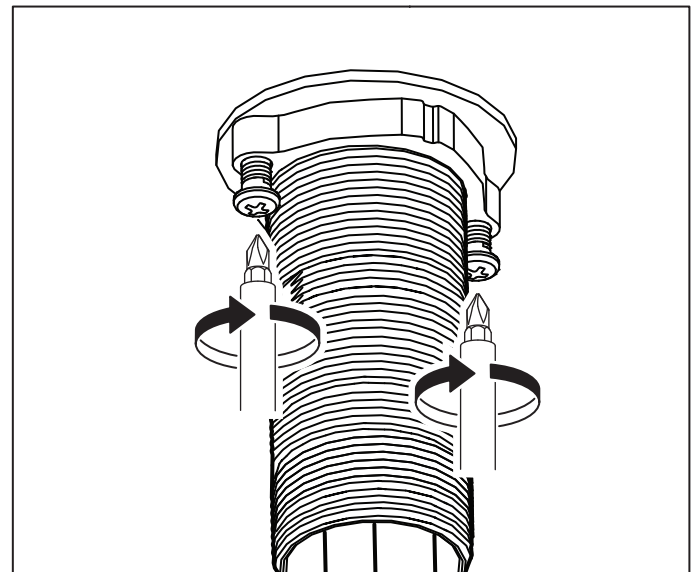
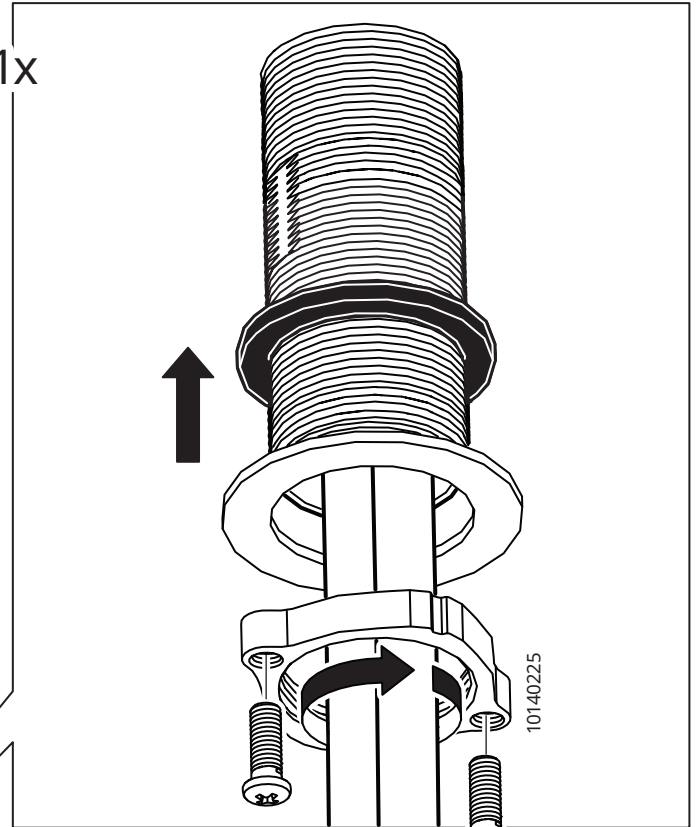

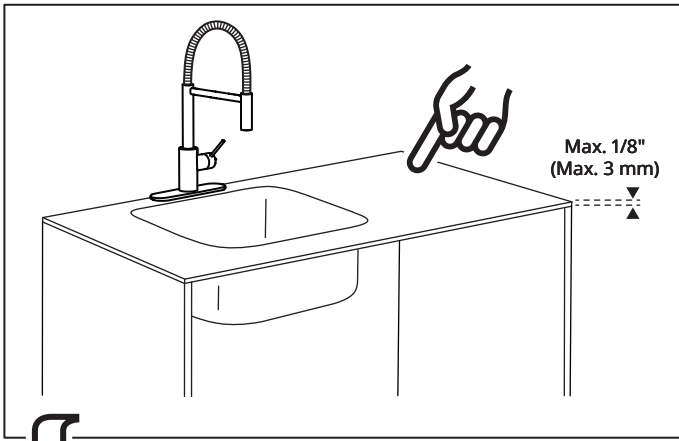

3

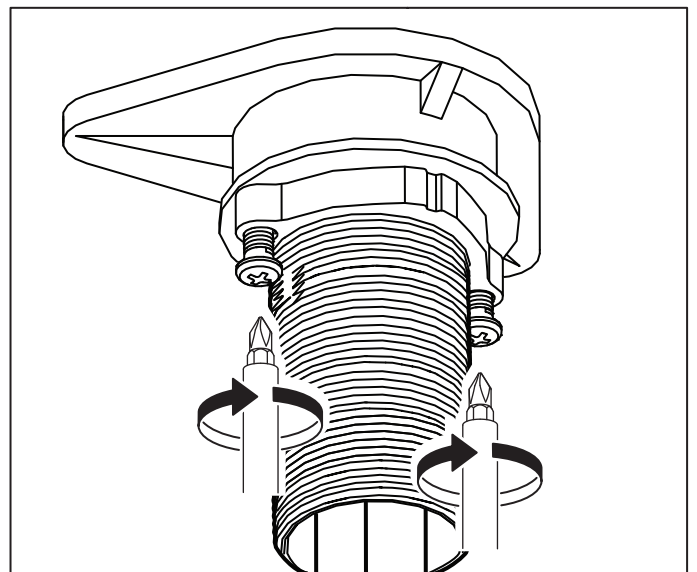
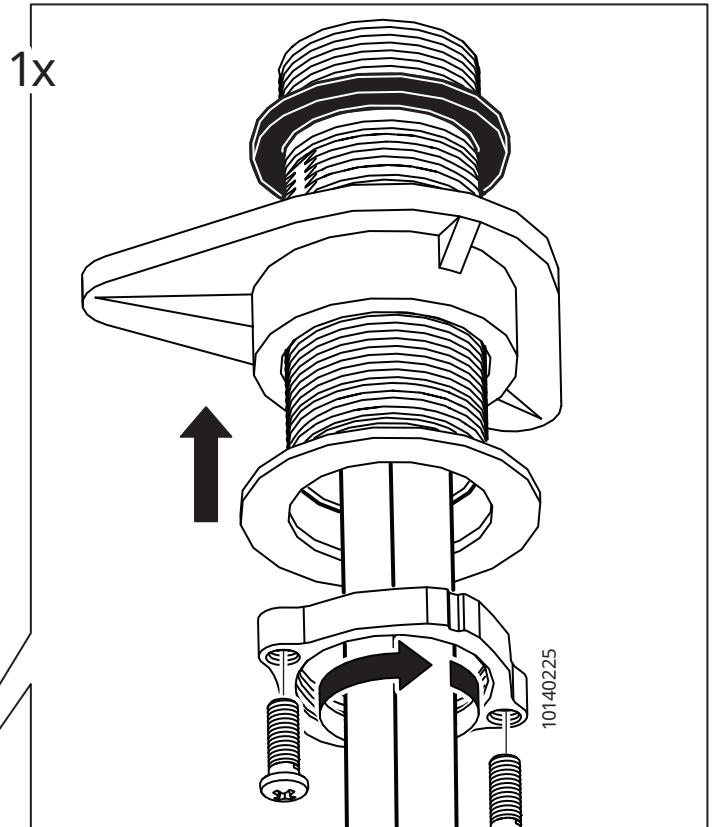
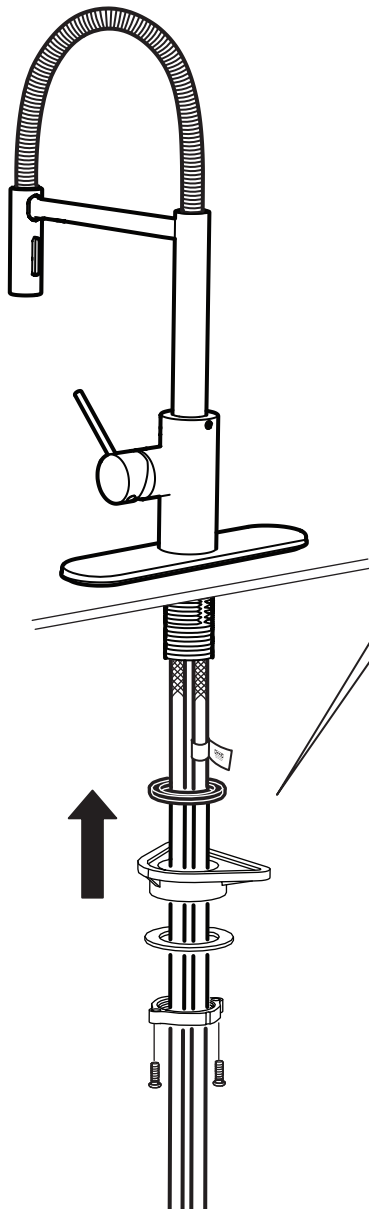

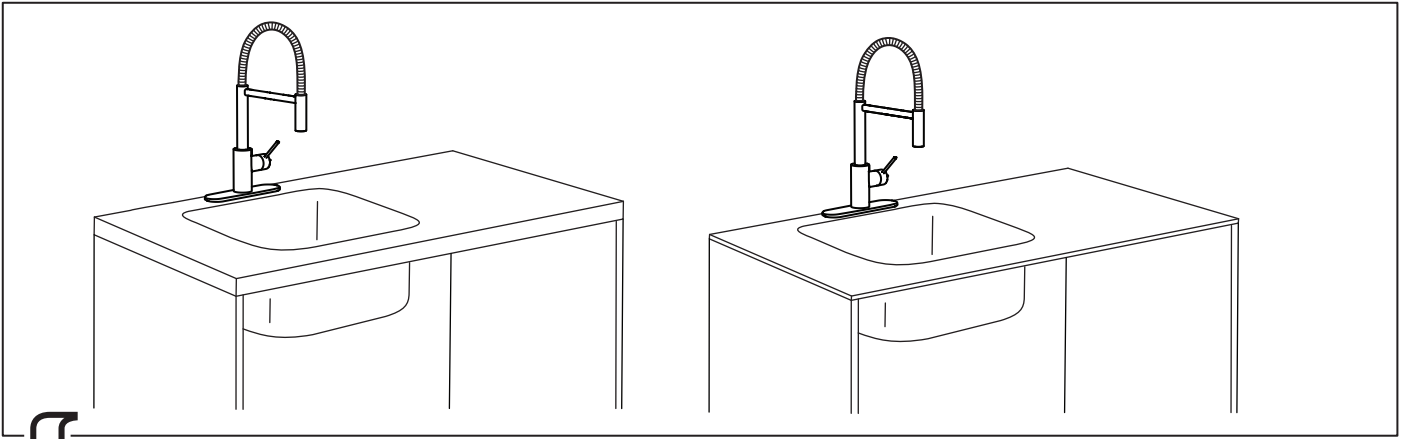

4

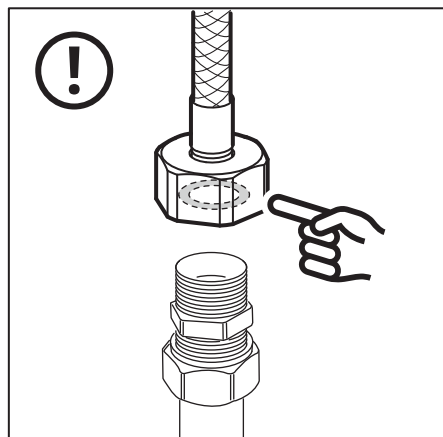
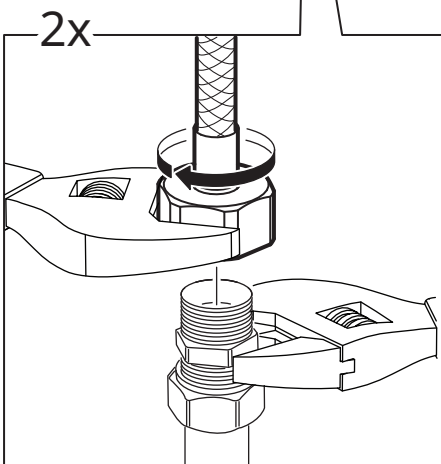
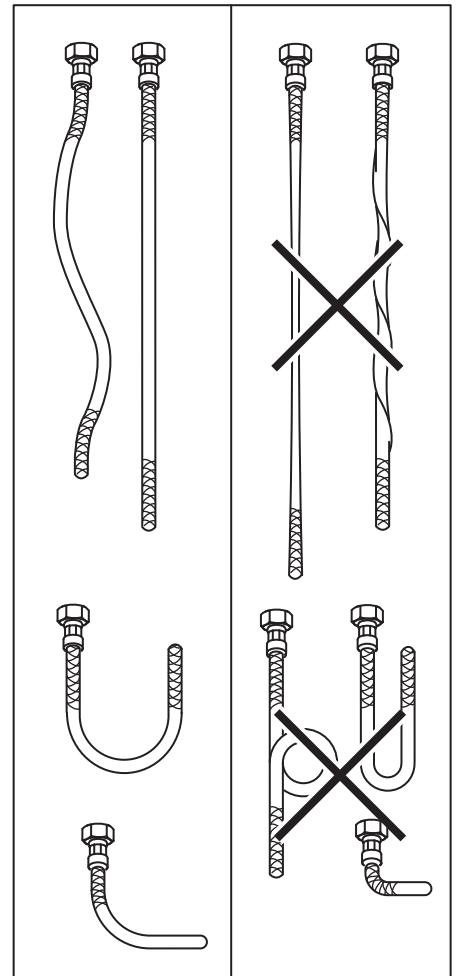
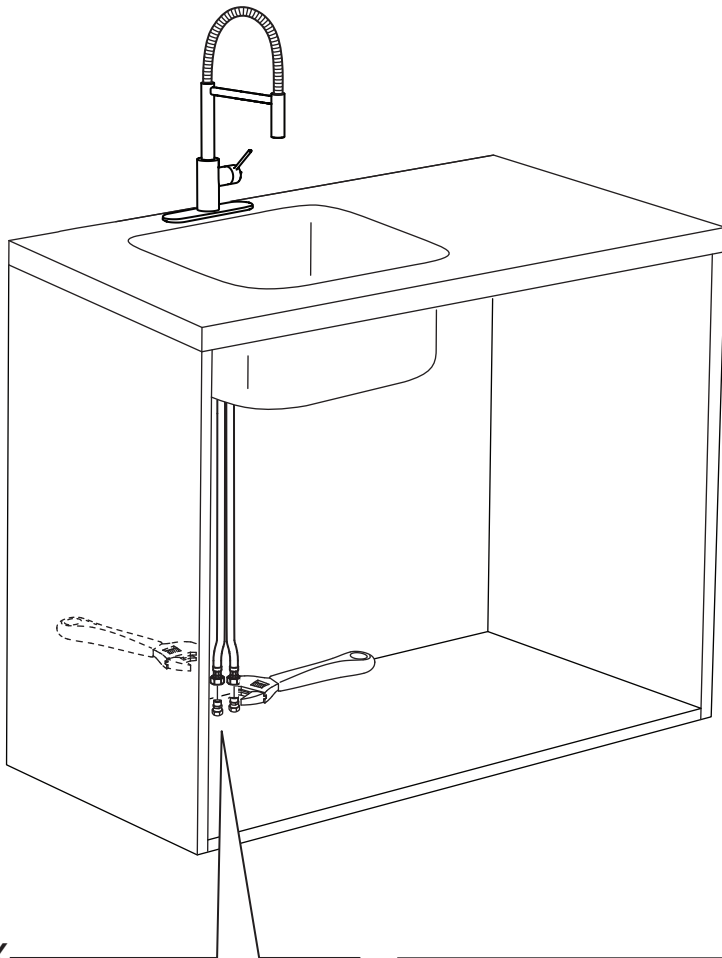



English

IMPORTANT! Do not tighten too hard: this can damage hoses/pipes and washers.

Français

ATTENTION ! Ne pas serrer trop fort : cela pourrait abîmer les flexibles/tuyaux et les joints.

Español

¡ATENCIÓN! No aprietes demasiado, ya que se pueden dañar las tuberías/conductos y las juntas.

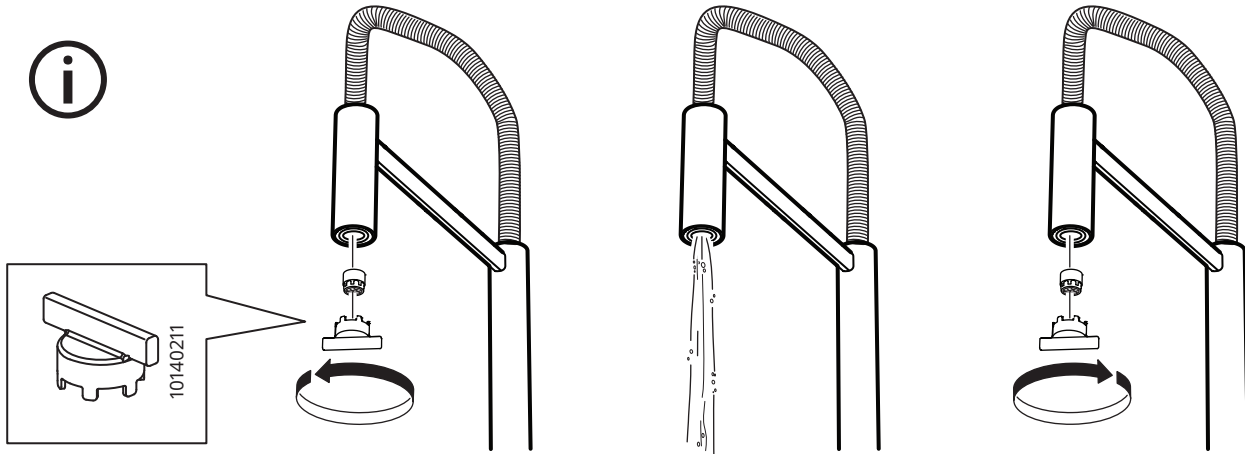

English

Before use: Unscrew the Aerator/Flow Guide and allow the water to run freely for a few minutes. Then screw the Aerator/Flow Guide back in place. Ensure that it is tight to prevent removal by hand.

Français

Avant utilisation : dévisser l'aérateur/guide d'écoulement et laisser couler pendant quelques minutes. Puis remettre l'aérateur/guide d'écoulement à sa place et le visser. Assurez-vous qu'il est assez serré pour ne pas être retiré à la main.

Español

Antes de utilizarlo: desenrosca el aireador/guía de desagüe y deja correr el agua libremente durante unos minutos. A continuación enróscalo de nuevo. Comprueba que está bien apretado, como para no poderlo retirarlo a mano.



English

Check at regular intervals to make sure that the installation is not leaking.

Français

Vérifier à intervalles réguliers que l'installation ne fuit pas.

Español

Comprobar a intervalos regulares que la instalación no gotee.

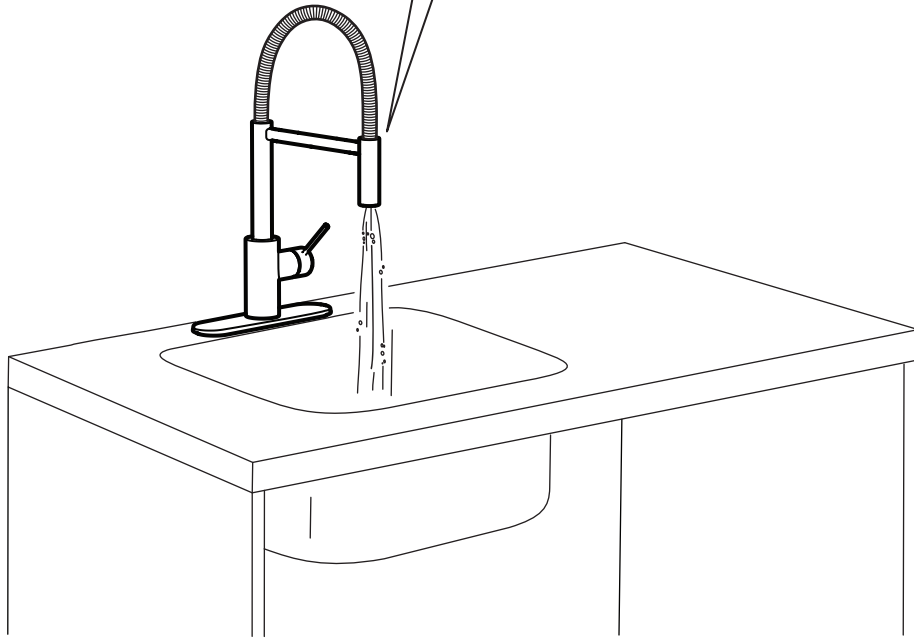
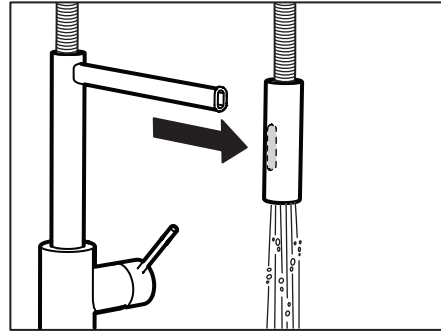
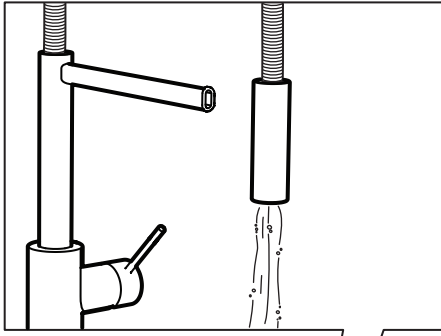

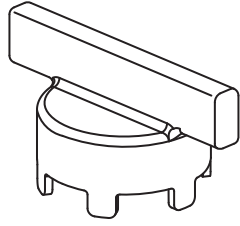

10140211

