

MACKSJÖN

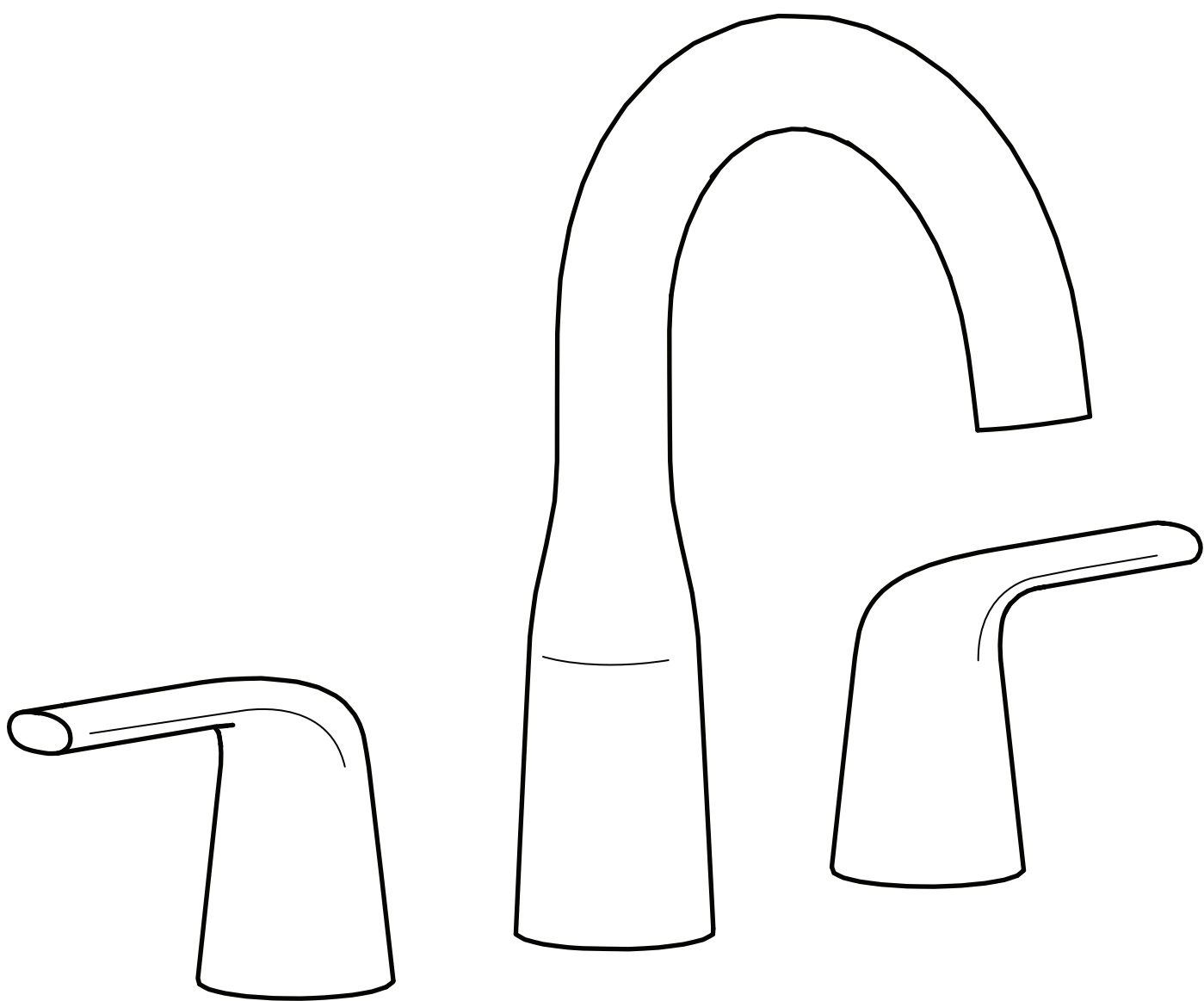

Design and Quality
IKEA of Sweden



English

Installation must be performed in compliance with current local construction and plumbing regulations. If in doubt, contact a professional.

Français

L'installation doit être réalisée en conformité avec les normes actuelles relatives à la construction et à la plomberie. En cas de doute, contacter un professionnel.

Español

La instalación debe realizarse siguiendo las normativas actuales sobre construcción y fontanería. En caso de duda, ponte en contacto con un profesional.



English

Switch off main shut-off valve before changing mixer tap.

Français

Fermer le robinet central d'eau avant de changer le mitigeur.

Español

Cierra la llave de paso general antes de cambiar el grifo.

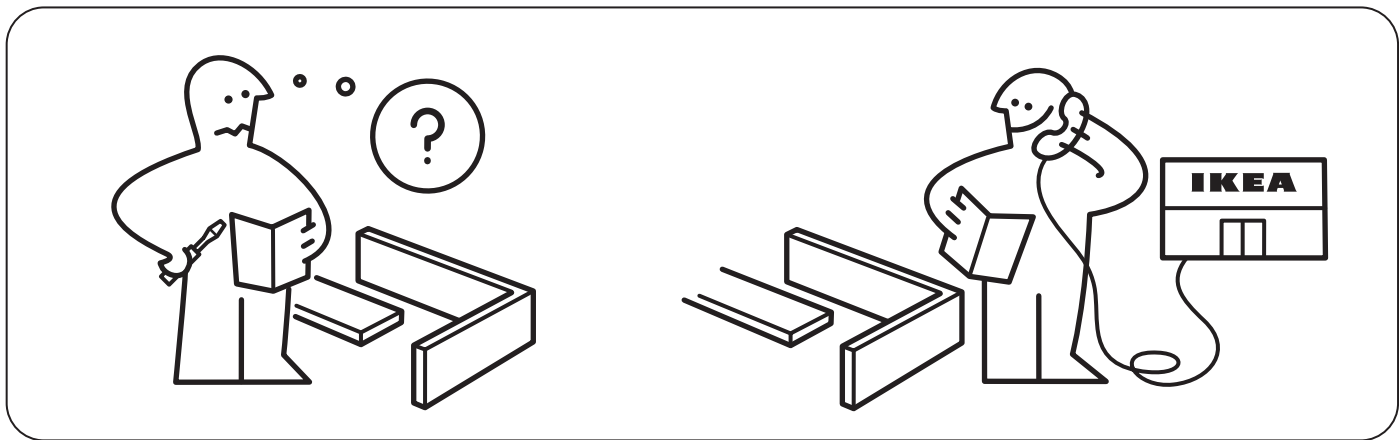
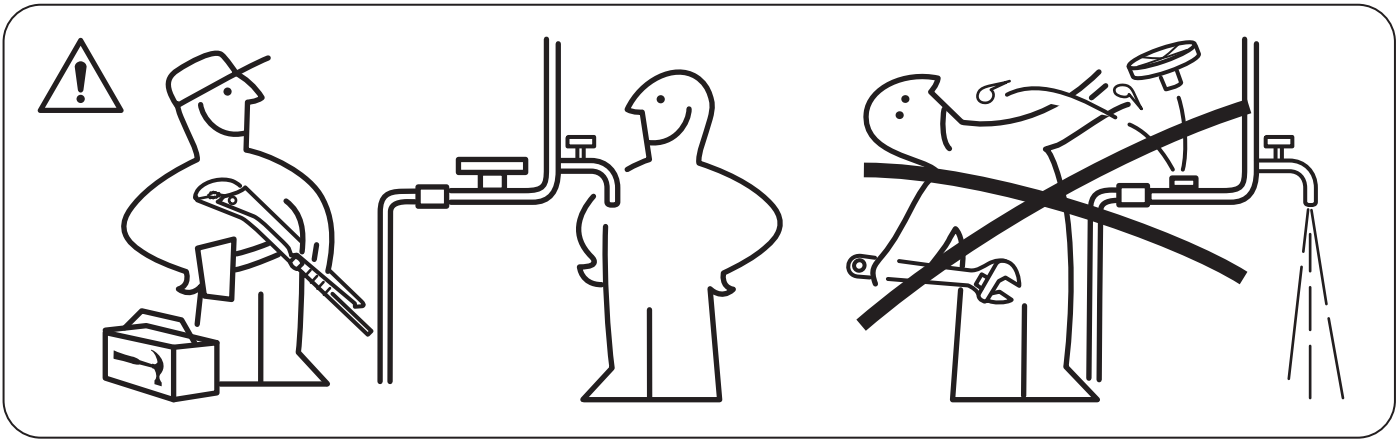
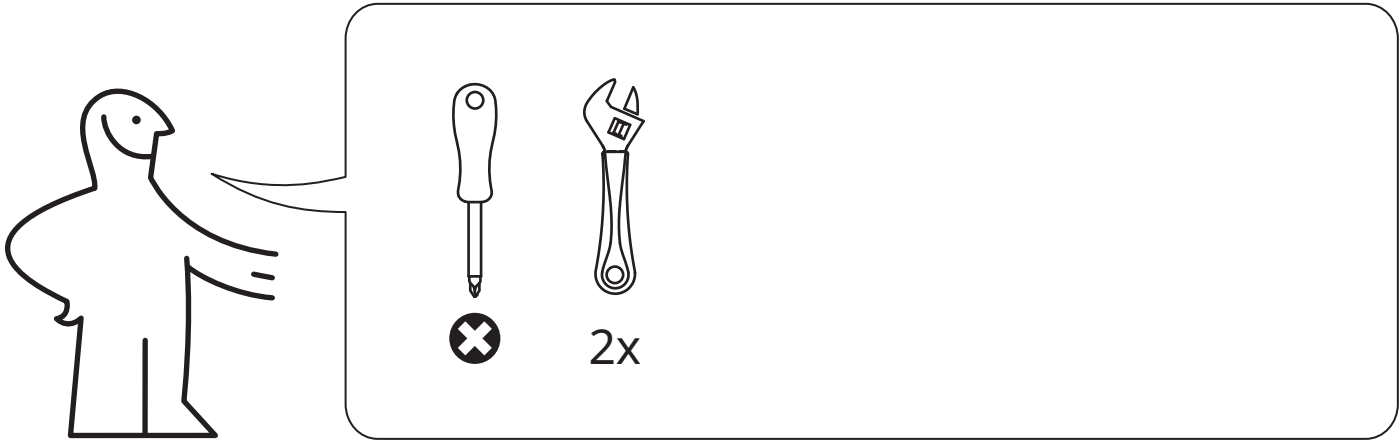

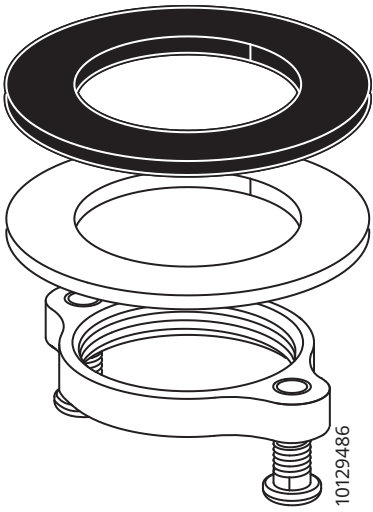

10129486

2x

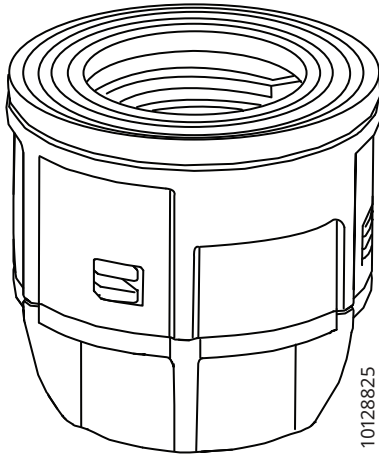

10128825

1x

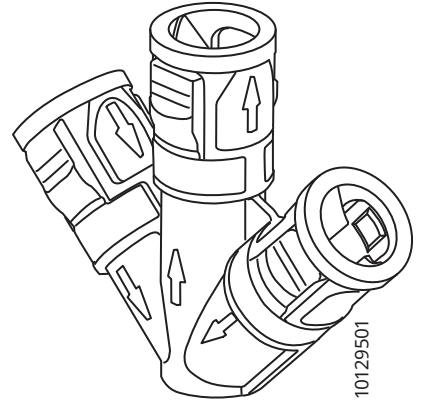

10129501

1x

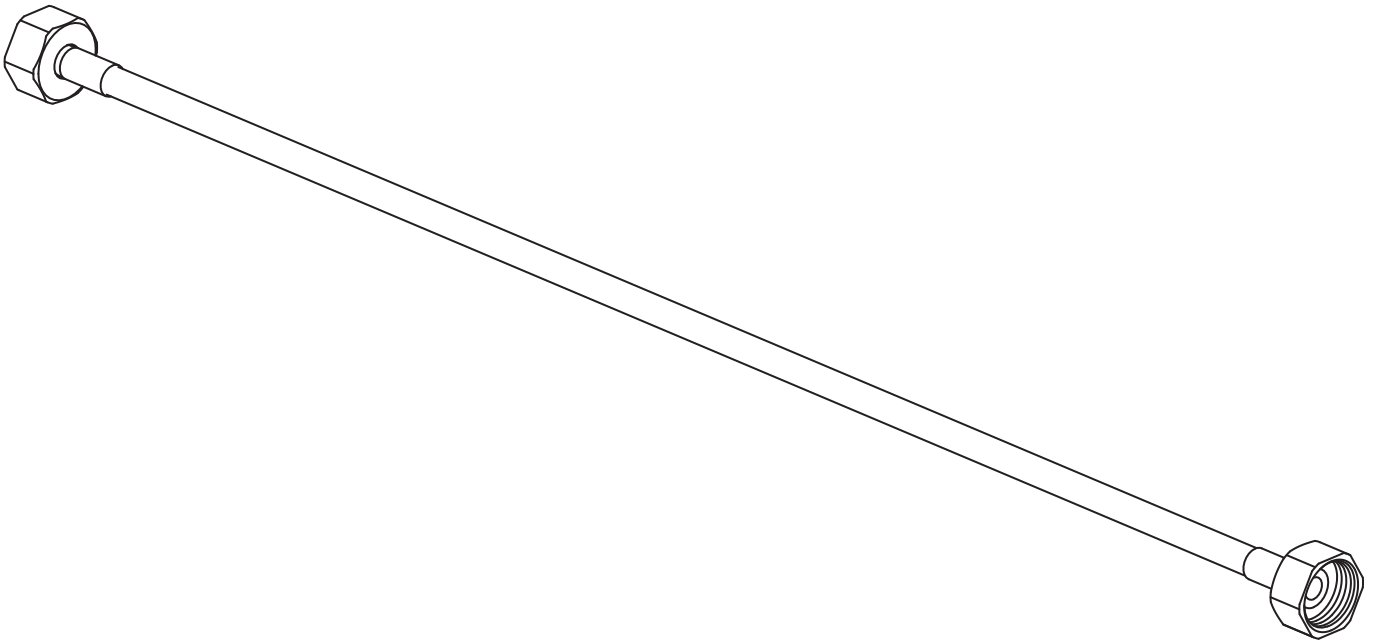

10132075

2x

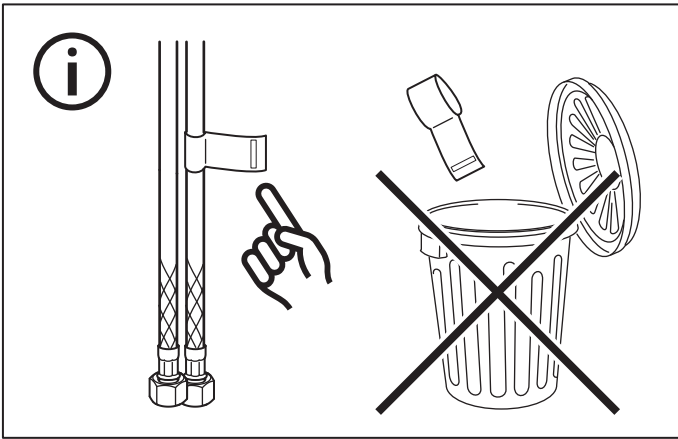

The diagram shows an information icon 'i' on the left. In the center is a vertical thermometer. On the right is a circular pressure gauge with two scales: the outer scale is in bar (0 to 10) and the inner scale is in psi (0 to 145). Below the thermometer and gauge are the following specifications:

140°F
60°C
(Max. 176°F
Max. 80°C)

1 - 5 bar
14,5 - 72,5 psi
(0,5 - 10 bar
7,2 - 145 psi)

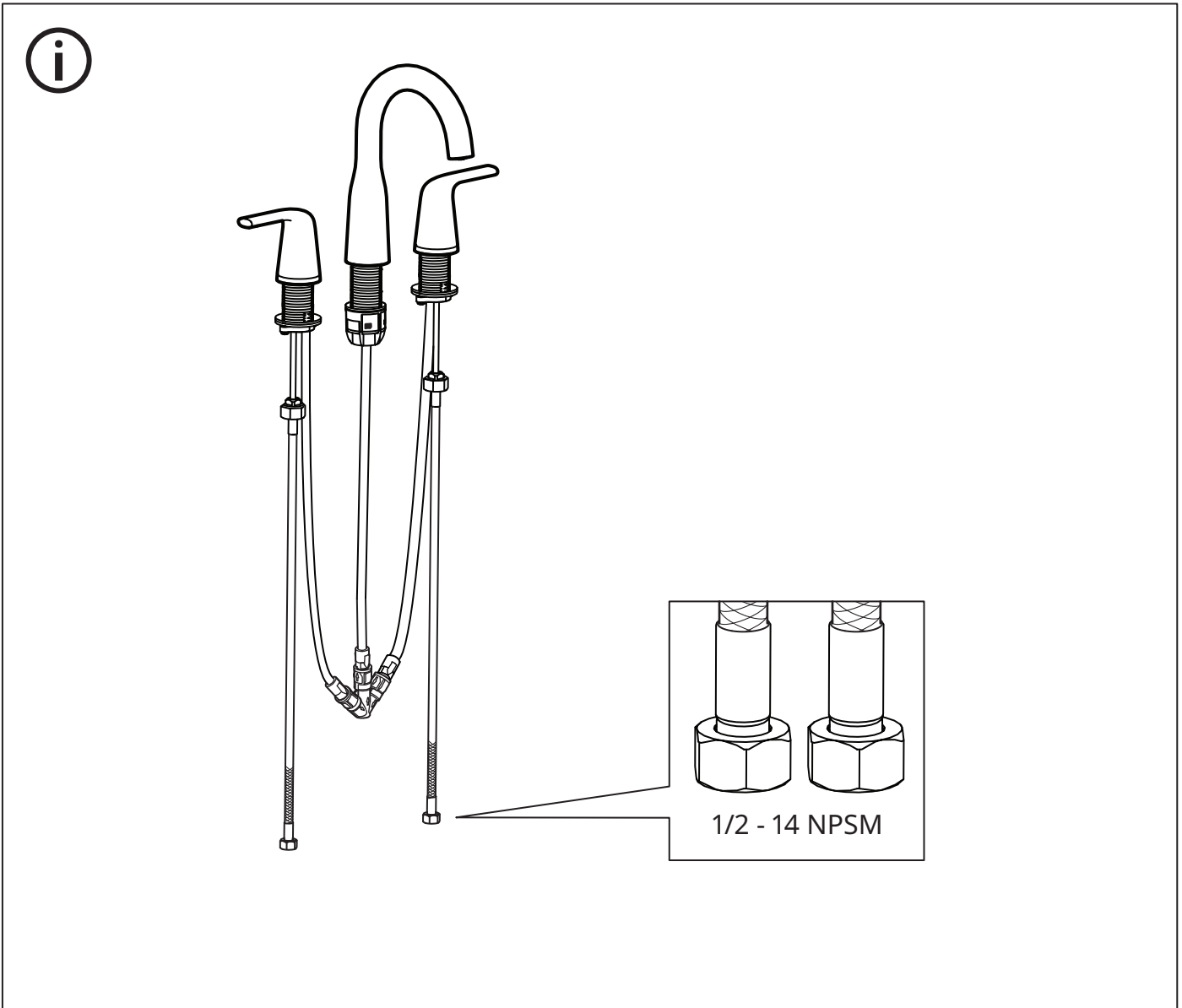

1

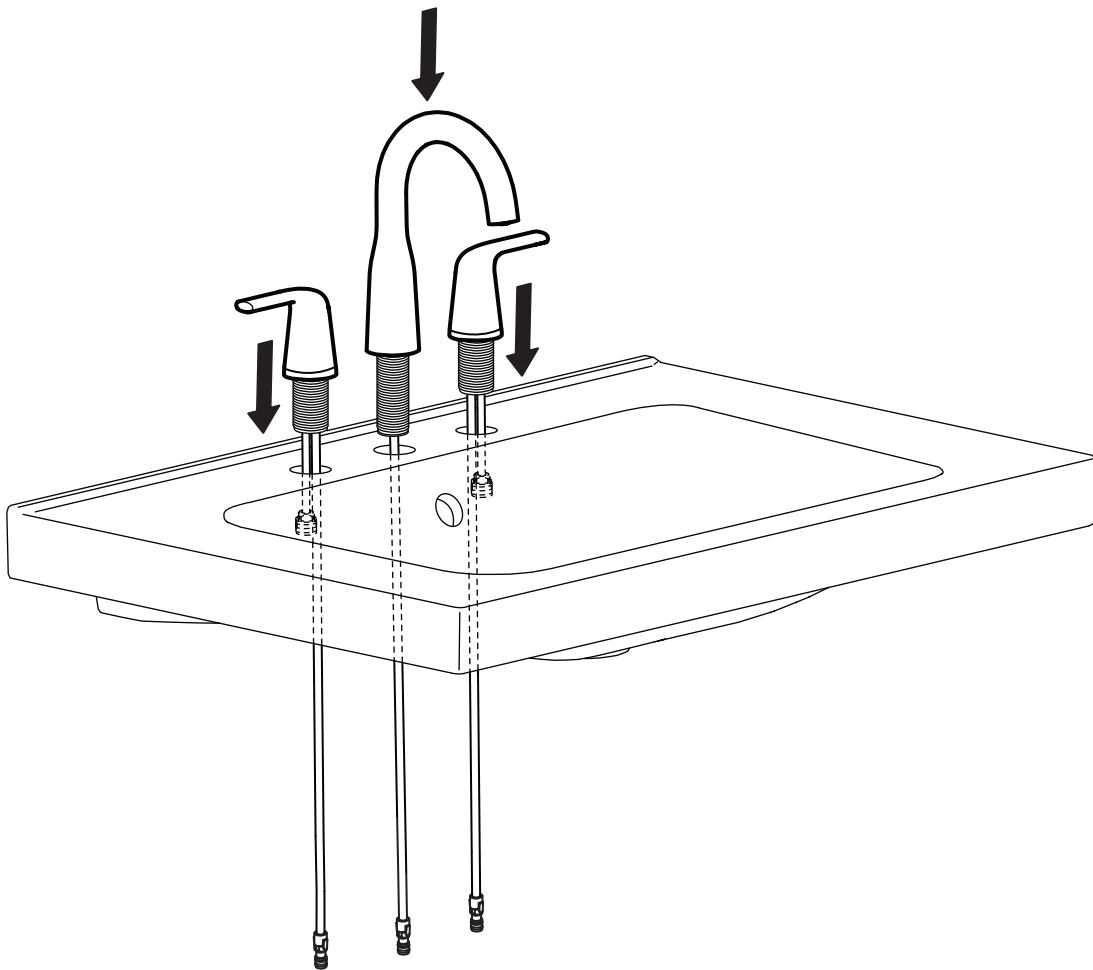
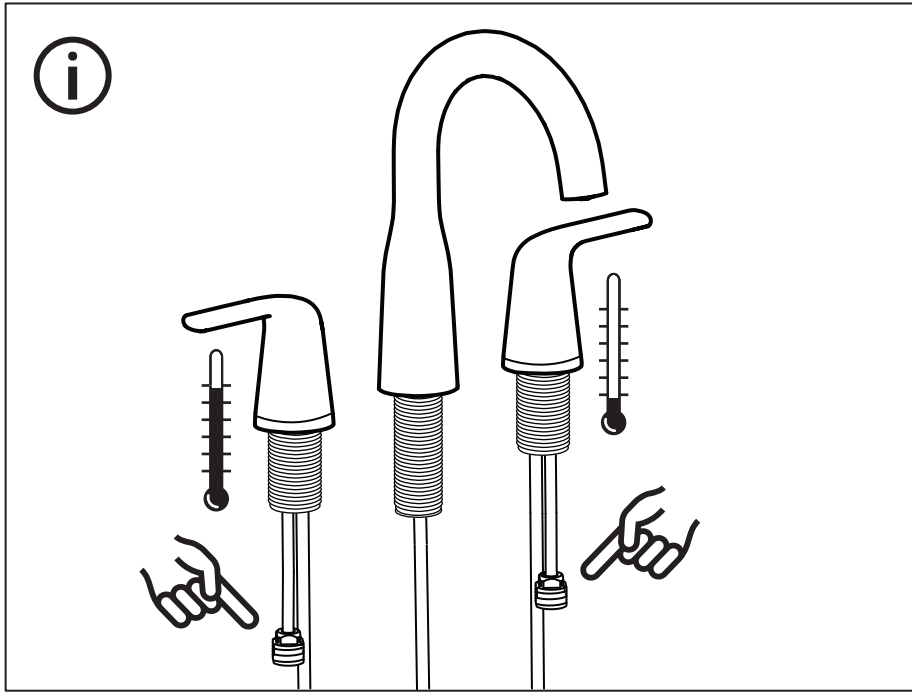

2

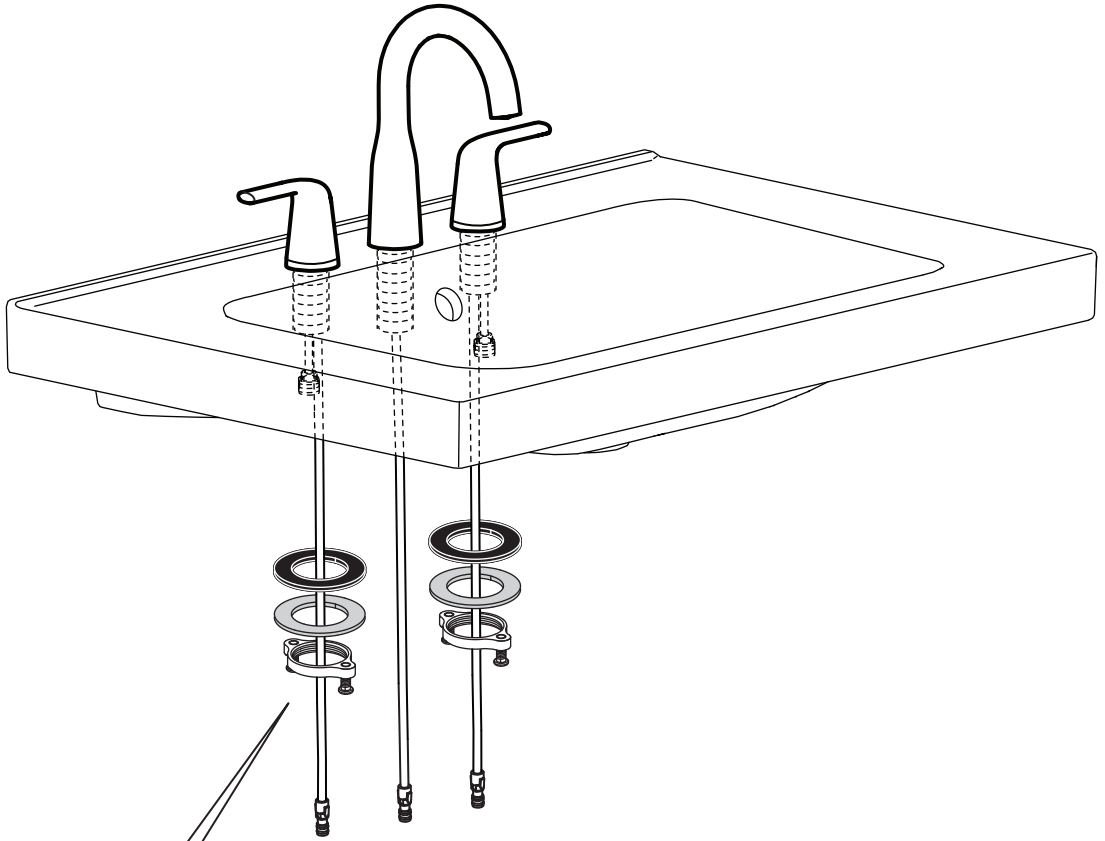

2x

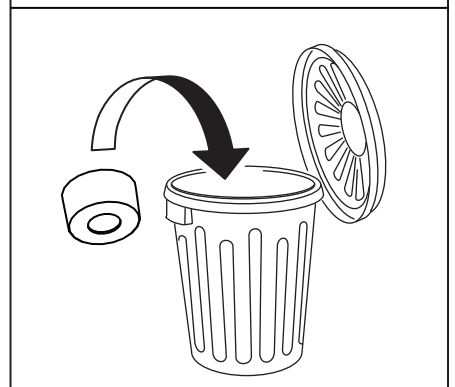
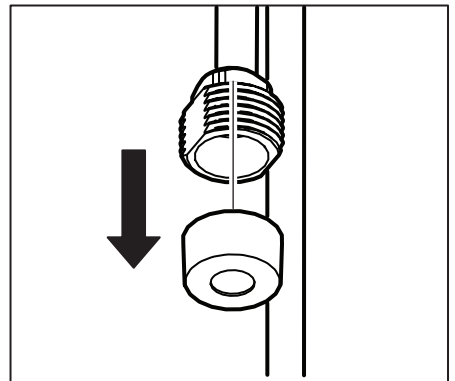
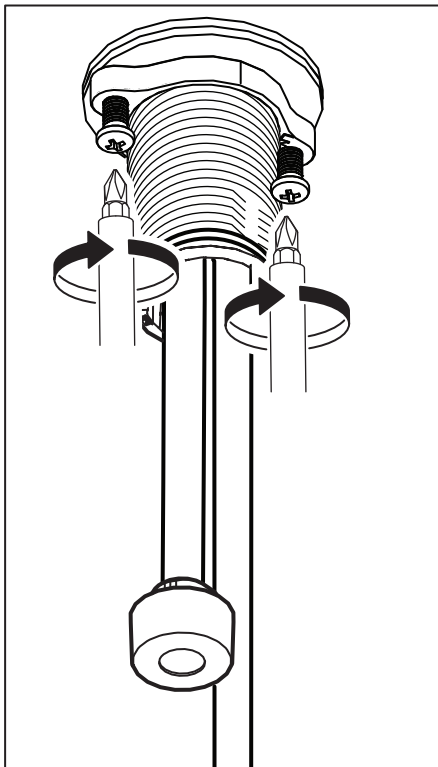
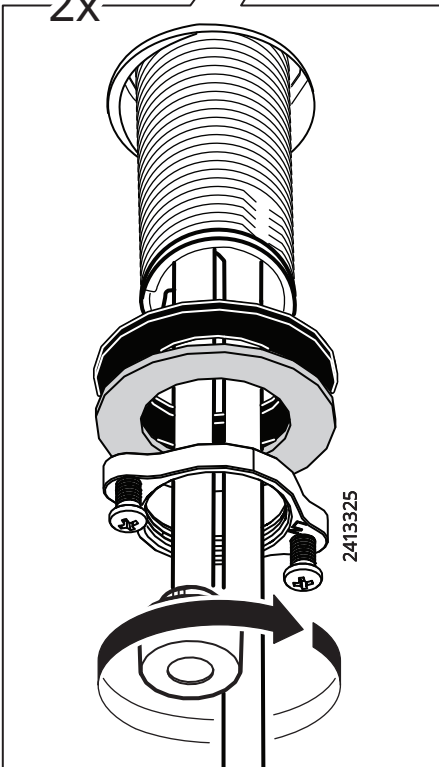

3

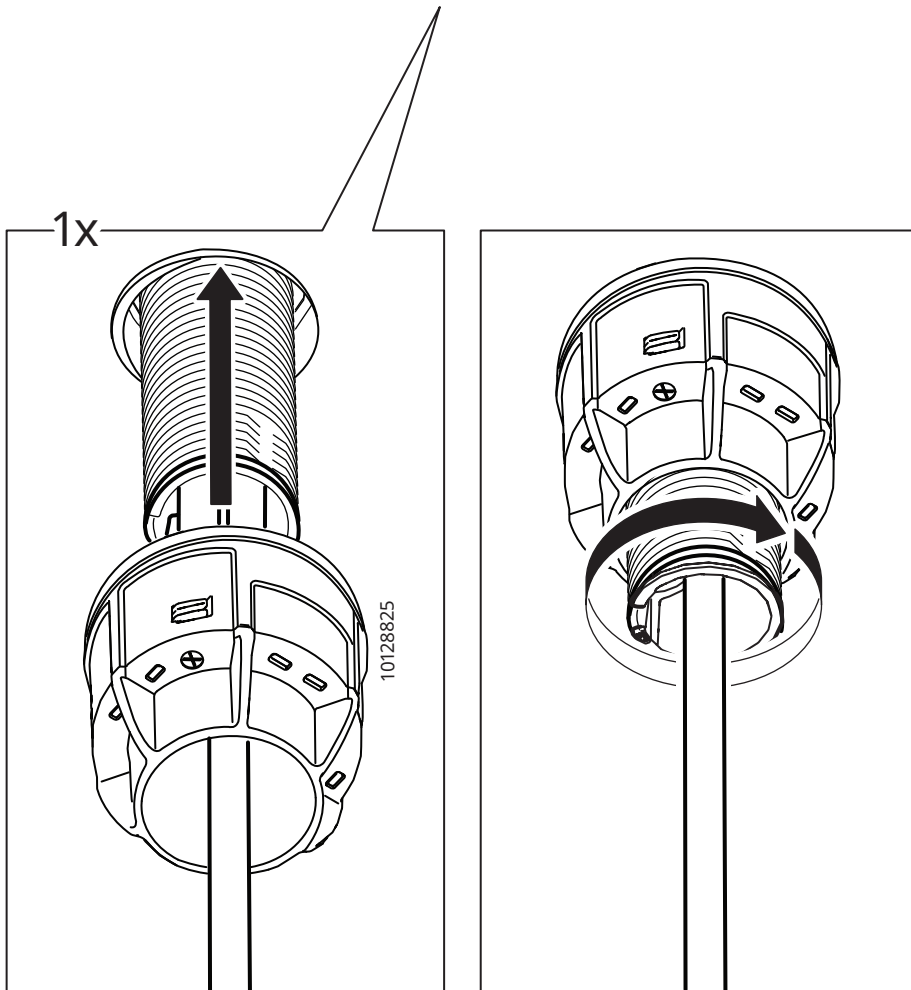
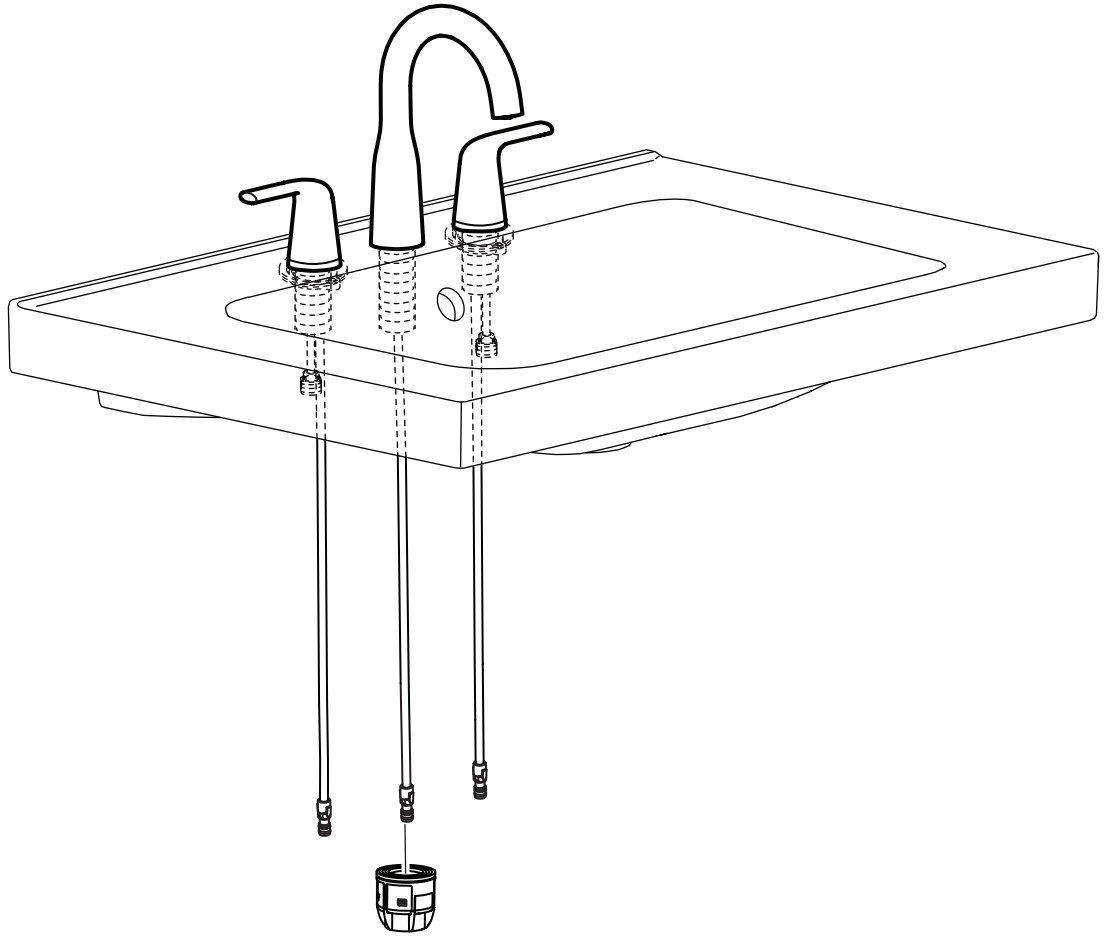

4

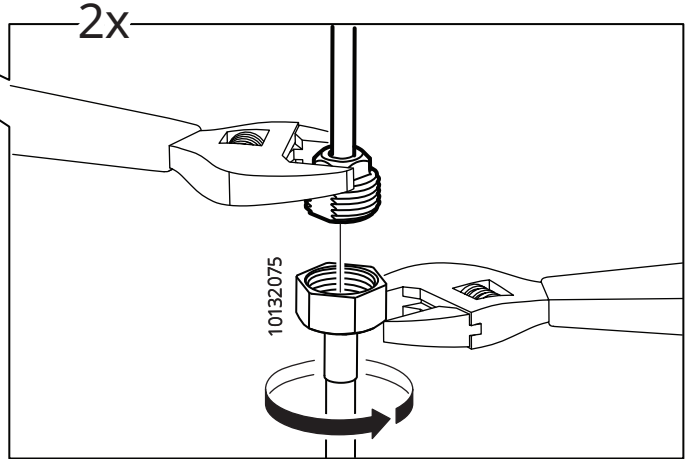
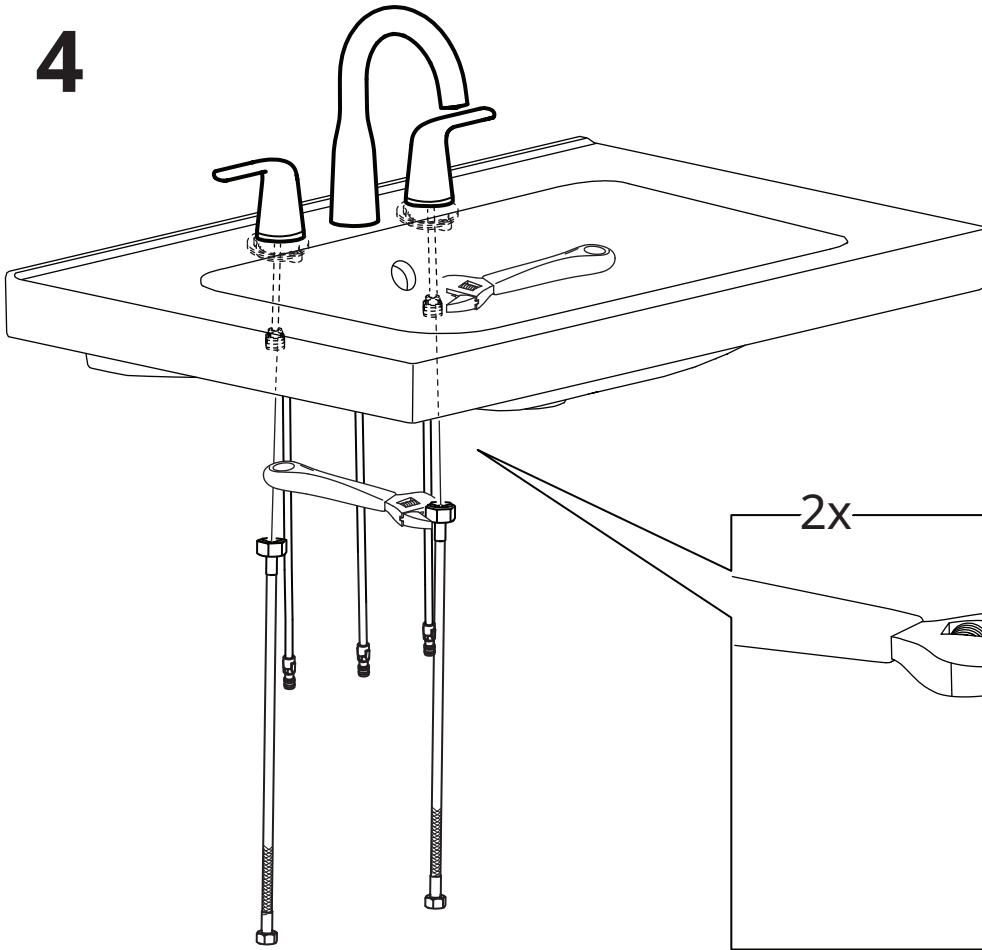

5

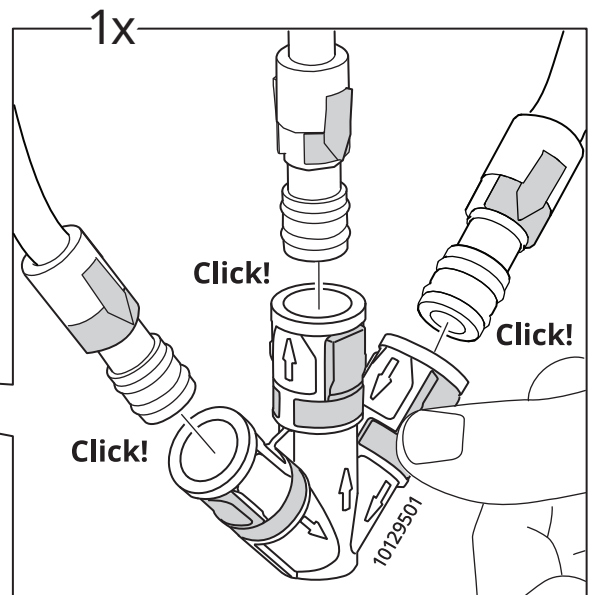
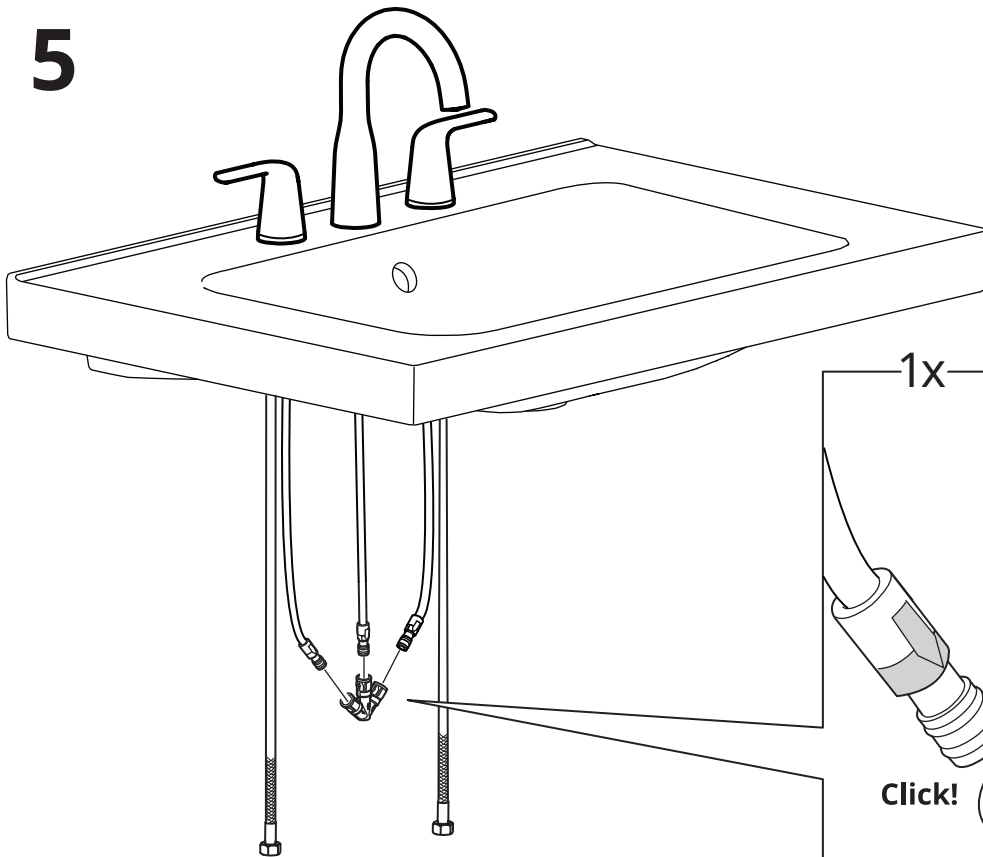

6

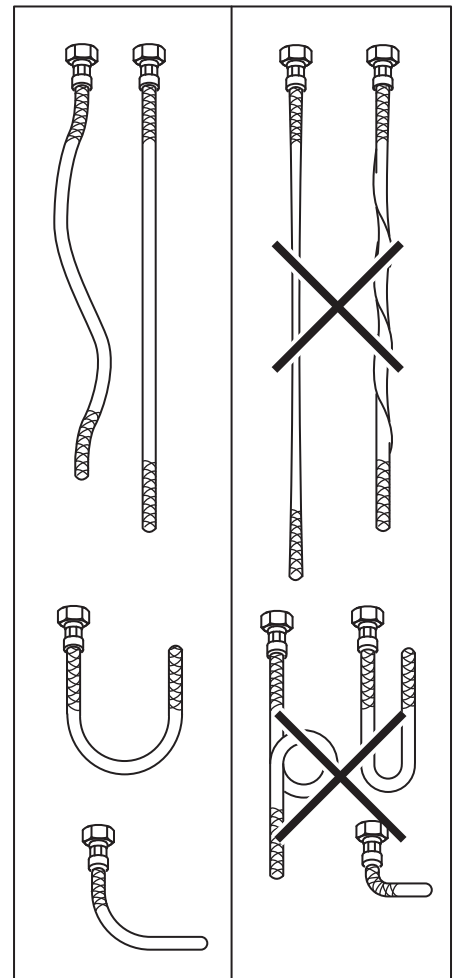
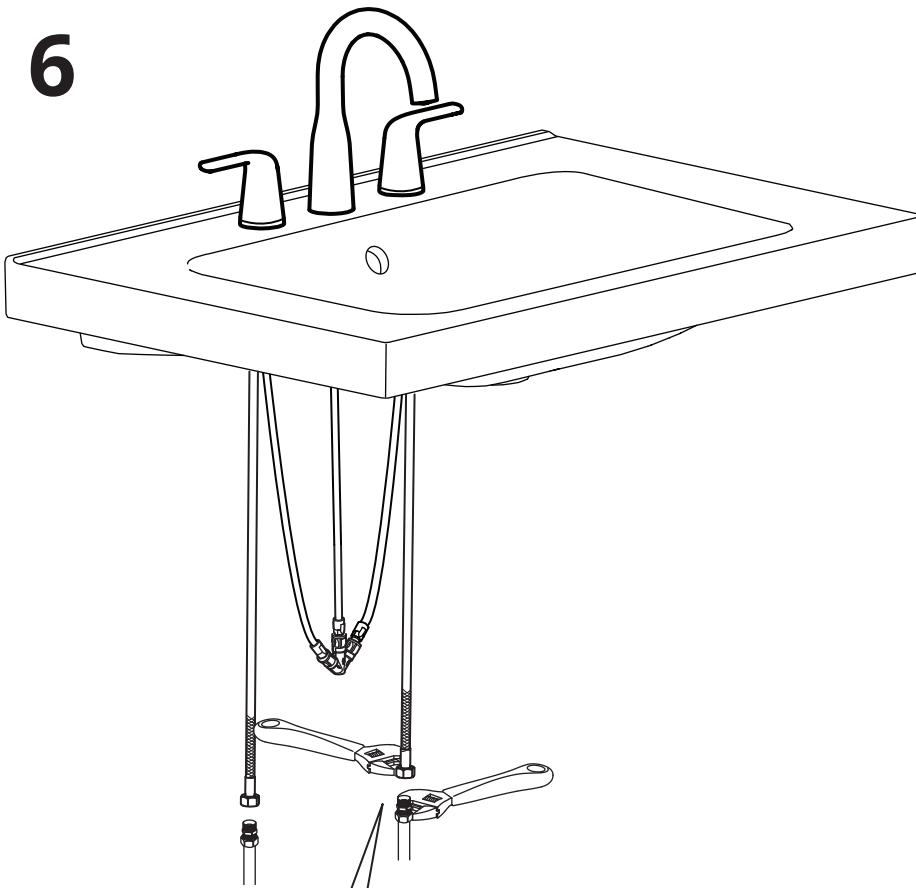

2x

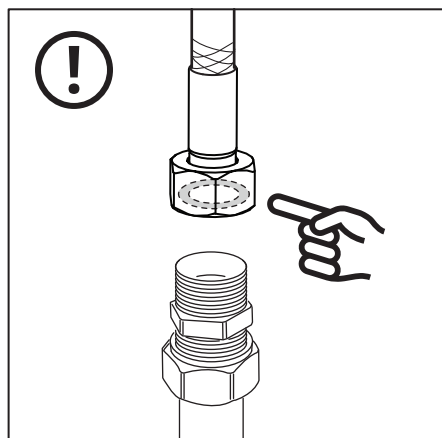
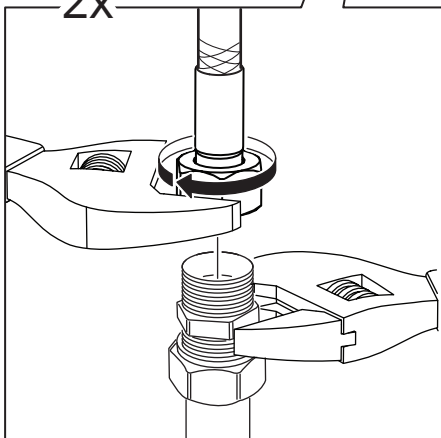

English

IMPORTANT! Do not tighten too hard: this can damage hoses/pipes and washers.

Français

ATTENTION ! Ne pas serrer trop fort : cela pourrait abîmer les flexibles/tuyaux et les joints.

Español

¡ATENCIÓN! No aprietes demasiado, ya que se pueden dañar las tuberías/conductos y las juntas.

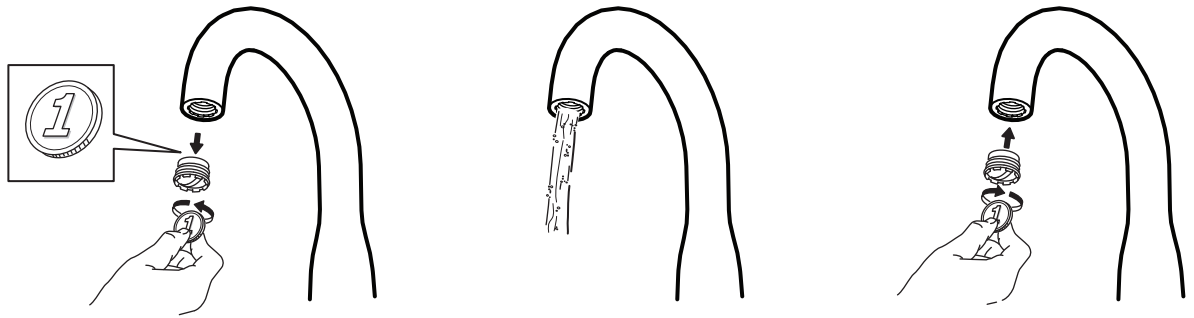

English

Before use: Unscrew the Aerator/Flow Guide with a coin and allow the water to run freely for a few minutes. Then screw the Aerator/Flow Guide back in place up to the stop DO NOT OVER TIGHTEN.

Français

Avant utilisation : dévisser l'aérateur/guide d'écoulement à l'aide d'une pièce de monnaie et laisser couler l'eau pendant quelques minutes. Puis remettre l'aérateur/guide d'écoulement en place et le visser. Attention à ne pas trop serrer.

Español

Antes de utilizarlo: desenrosca el aireador/guía de desagüe con ayuda de una moneda y deja correr el agua libremente durante unos minutos. A continuación enróscalo de nuevo. Comprueba que está bien apretado, pero NO DEMASIADO.



English

Check at regular intervals to make sure that the installation is not leaking.

Français

Vérifier à intervalles réguliers que l'installation ne fuit pas.

Español

Comprobar a intervalos regulares que la instalación no gotee.

