

BERGIG

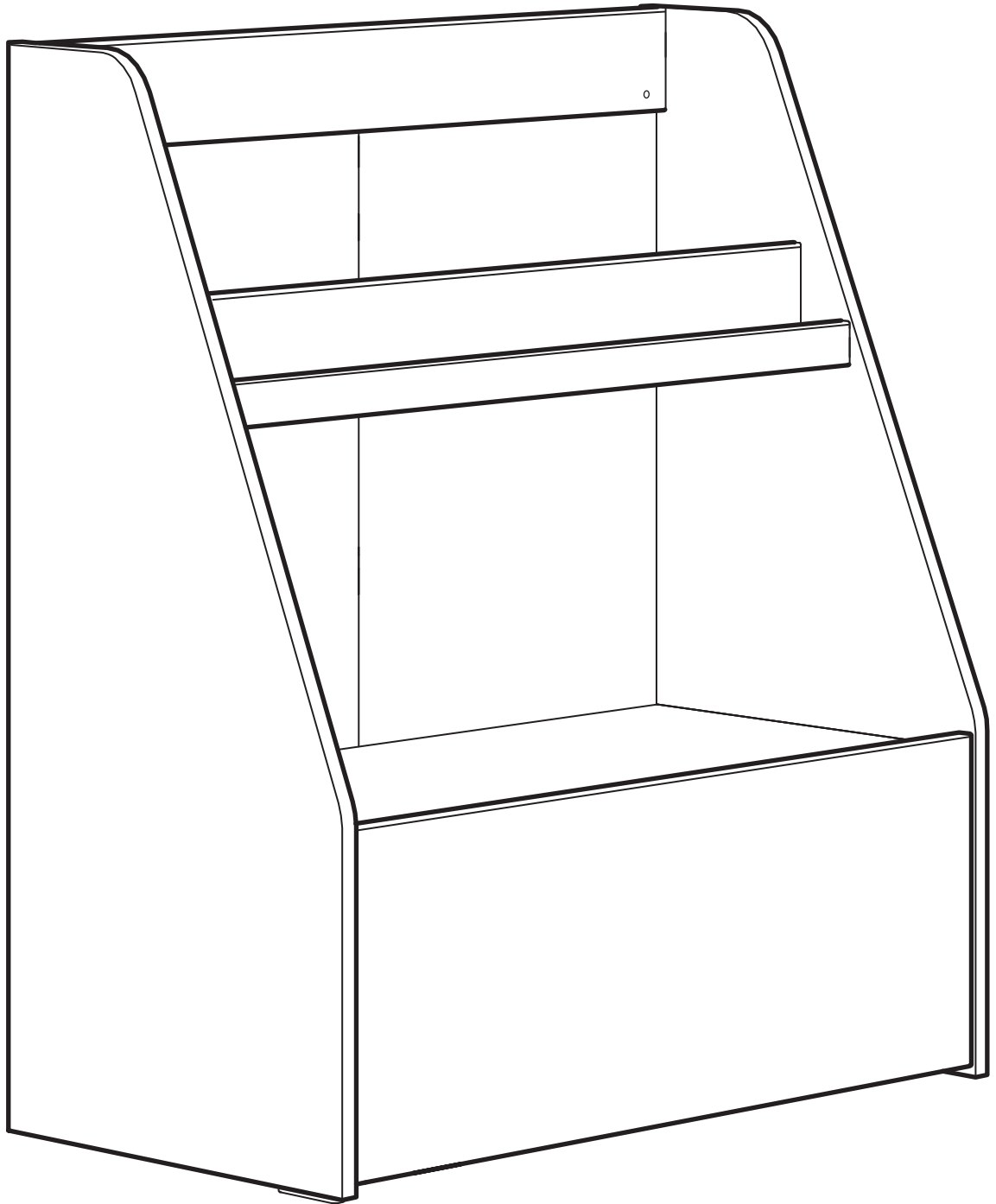

Design and Quality
IKEA of Sweden

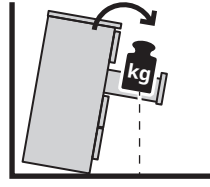
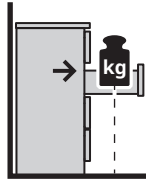

English

WARNING!

Serious or fatal crushing injuries can occur from furniture tip-over. To reduce the risk of furniture tip-over:

ALWAYS secure this furniture to the wall using tip-over restraints.

To further reduce the risk of serious injury and death from tip-overs:

- Place heaviest items in the lower drawer.
- Do not set TVs or other heavy objects on top of this product.
- Never let children climb or hang on drawers, doors, or shelves.
- Read and follow each step of the instruction carefully.

Español

ADVERTENCIA:

Si el mueble volcase, podría provocar lesiones graves e incluso mortales. Para limitar el riesgo de vuelco de los muebles:

Fija SIEMPRE el mueble a la pared con herrajes antivuelco.

Para reducir más el riesgo de daños graves o mortales por el vuelco del mueble:

- Coloca los objetos más pesados en el cajón inferior.
- No pongas la televisión u otros objetos pesados en la parte superior del mueble.
- Nunca permitas que los niños trepen o se cuelguen de los cajones, baldas o puertas.
- Lee y sigue cada paso de las instrucciones cuidadosamente.

Português

AVISO!

Podem ocorrer ferimentos graves ou fatais devido à queda de móveis. Para diminuir o risco de queda de móveis:

Fixe SEMPRE este móvel à parede com acessórios de fixação.

Para reduzir ainda mais o risco de lesões graves e morte devido a queda de móveis:

- Coloque os objetos mais pesados nas gavetas mais baixas.
- Não coloque televisões ou outros objetos pesados em cima deste artigo.
- Nunca permita que as crianças trepem ou se pendurem nas gavetas, portas ou prateleiras.
- Leia e siga cuidadosamente as instruções.

中文

安全警示!

家具傾倒可能导致严重或致命的伤害。为降低家具傾倒的風險:

请务必使用防翻倒约束装置,以便将家具固定在牆面。

为进一步降低家具翻倒而造成的重伤或死亡風險:

- 请将重物放在低层抽屉中。
- 请勿将电视机或其它重物放在该产品顶部。
- 请勿让儿童攀爬或悬挂在抽屉、柜门或搁板上。
- 请仔细阅读并按照说明中的每个步骤进行操作。

繁體

警告!

家具傾倒可能造成嚴重或致命的傷害。為降低家具傾倒的風險:

- 務必使用固定配件將此家具固定在牆上。
- 家具傾倒或會造成嚴重或致命的傷害:
- 請將重物放置在底層抽屜。
- 請勿將電視或其他重物放在此產品的上方。
- 切勿讓兒童攀爬或懸掛在抽屜、門板或層架上。
- 請仔細閱讀並依照說明書的步驟。

한국어

경고!

가구 전복 사고가 발생하면 심각한 부상을 입을 수 있습니다. 가구가 넘어질 위험을 줄이려면 다음과 같은 조치를 취하세요.

가구는 전복 사고 방지용 부품으로 벽에 반드시 고정하세요.

심각한 부상이나 사망에 이를 수 있는 가구 전복 방지를 위해서는 다음과 같이 하세요.

무거운 물건은 아래쪽 서랍에 보관하세요.

본 제품 위에 무거운 물건이나 TV를 두지 마세요.

아이들이 서랍이나 도어, 선반 등을 타고 오르거나 매달리지 않게 하세요.

지침의 각 단계를 자세히 읽고 따르세요.

日本語

警告!

家具の転倒により、家具の下敷きになって大ケガ、あるいは生命にかかわるような傷害を負う危険があります。家具の転倒のリスクを減らすために以下のことを守ってください。

転倒防止用固定具を用いて、必ず本製品を壁に固定してください。

家具の転倒による重大なケガや死亡事故を防ぐため、

- 重い物は下段の引き出しに入れてください。
- 本製品の上にテレビなどの重いものを置かないでください。
- 安全のため、引き出しや扉、棚の上によじ登ったり、ぶら下がったりしないよう、お子さまにご指導ください。
- 注意事項をよく読み、手順に従ってください。

Bahasa Indonesia

PERINGATAN

Cedera serius dapat terjadi akibat perabot terjatuh. Untuk mengurangi risiko furnitur terjatuh:

SELALU kencangkan perabot ke dinding dengan menggunakan alat pengencang.

Untuk mengurangi resiko cedera serius dan kematian akibat perabotan terjatuh:

- Letakkan benda berat di laci paling bawah.
- Jangan meletakkan TV atau benda berat di atas produk ini.
- Jangan biarkan anak memanjat atau mengganduli laci, pintu dan rak.
- Baca dan ikuti setiap langkah petunjuk dengan seksama.

Bahasa Malaysia

AMARAN!

Kecederaan serius atau maut boleh berlaku akibat perabot terbalik. Bagi mengurangkan risiko perabot terbalik:

SENTIASA kukuhkan perabot ini pada dinding menggunakan penahan rebah.

Bagi mengurangkan lagi risiko kecederaan serius dan kematian akibat terbalik:

- Tempatkan barang paling berat di dalam laci paling bawah.
- Jangan letakkan TV atau lain-lain objek berat di atas produk ini.
- Jangan biarkan kanak-kanak memanjat atau bergayut pada laci, pintu, atau para-para.
- Baca dan ikuti setiap langkah arahan dengan teliti.

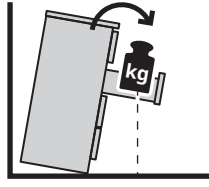
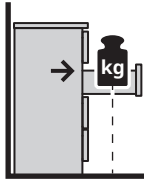

عربي

تحذير!

مخاطر تعرّض لإصابات خطيرة نتيجة انقلاب الأثاث. للحد من خطر انقلاب الأثاث:

يجب تثبيت هذا الأثاث دائماً على الحائط بواسطة أدوات التثبيت.

لتقليل مخاطر الإصابة الخطيرة والتعرض للموت نتيجة انقلاب الأثاث:

- يجب وضع الأشياء الثقيلة في الدرج السفلي.
- لا يجب وضع تلفزيون أو أي أشياء ثقيلة أخرى فوق هذا المنتج.
- يجب عدم السماح للأطفال بتسلق أو التعلّق على الأدراج، الأبواب، أو الأرفف.
- يرجى قراءة ومتابعة كل خطوة من التعليمات بدقة.

ไทย

คำเตือน!

หากเฟอร์นิเจอร์ล้มคว่ำอาจก่อให้เกิดการบาดเจ็บร้ายแรงหรืออันตรายถึงชีวิตได้ ปกป้องเฟอร์นิเจอร์ล้มโดยปฏิบัติตามนี้

ยึดเฟอร์นิเจอร์เข้ากับผนังเสมอด้วยอุปกรณ์ยึดเพื่อความปลอดภัย

ลดความเสี่ยงของการเกิดอุบัติเหตุและอันตรายร้ายแรงถึงชีวิตโดยปฏิบัติตามนี้

- วางของที่มีน้ำหนักมากที่สุดไว้บนชั้นด้านล่าง
- ไม่วางโทรทัศน์หรือสิ่งของหนักๆ ไว้บนสินค้า
- ไม่ปล่อยให้เด็กปีนป่ายหรือห้อยโหนสินค้า บนตู้ หรือชั้นวาง
- โปรดอ่านคำแนะนำนี้ให้ละเอียดครบถ้วนและปฏิบัติตามทีละขั้นตอน

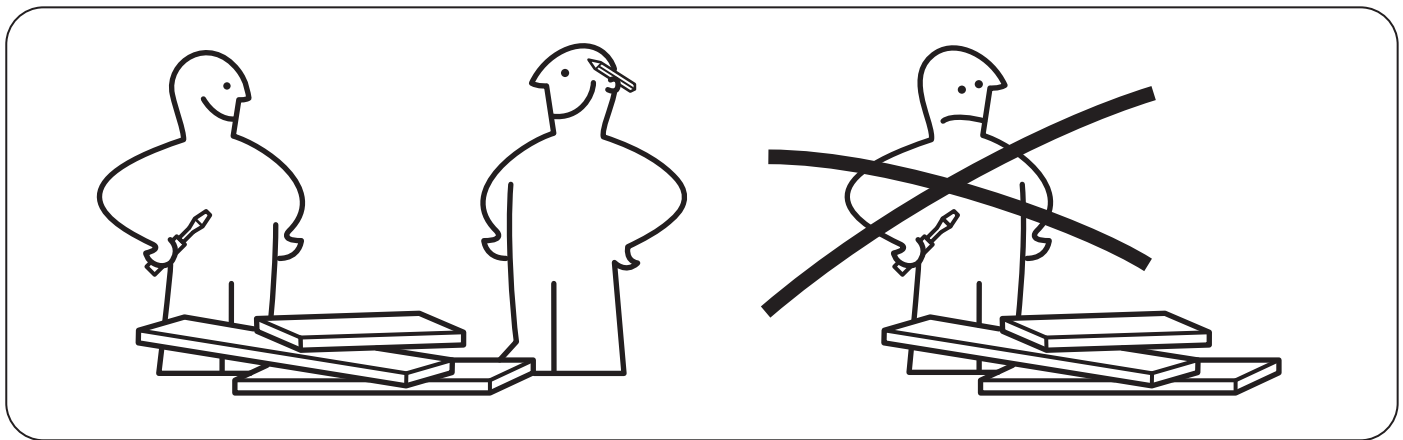
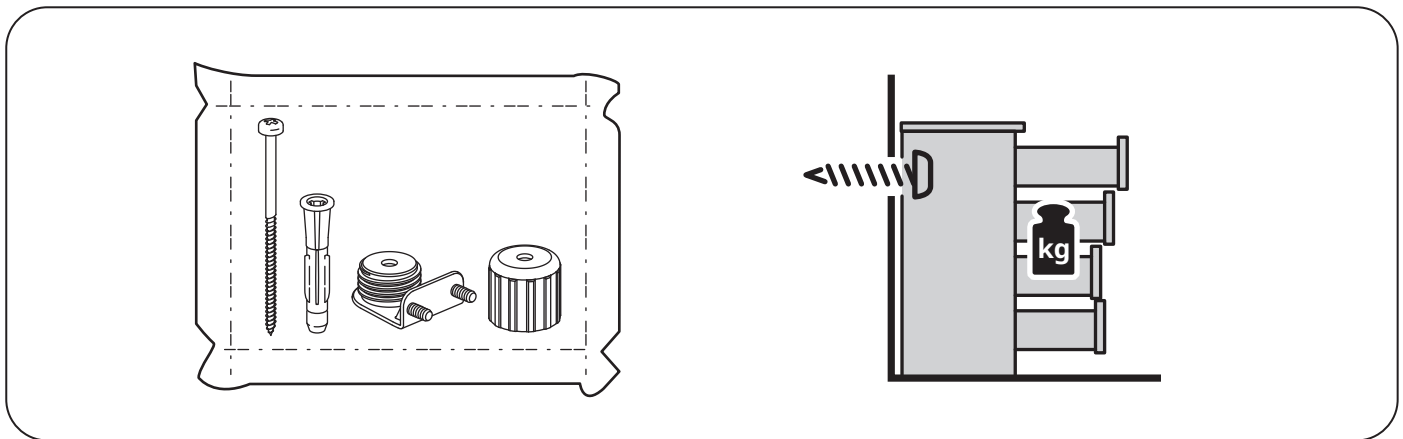
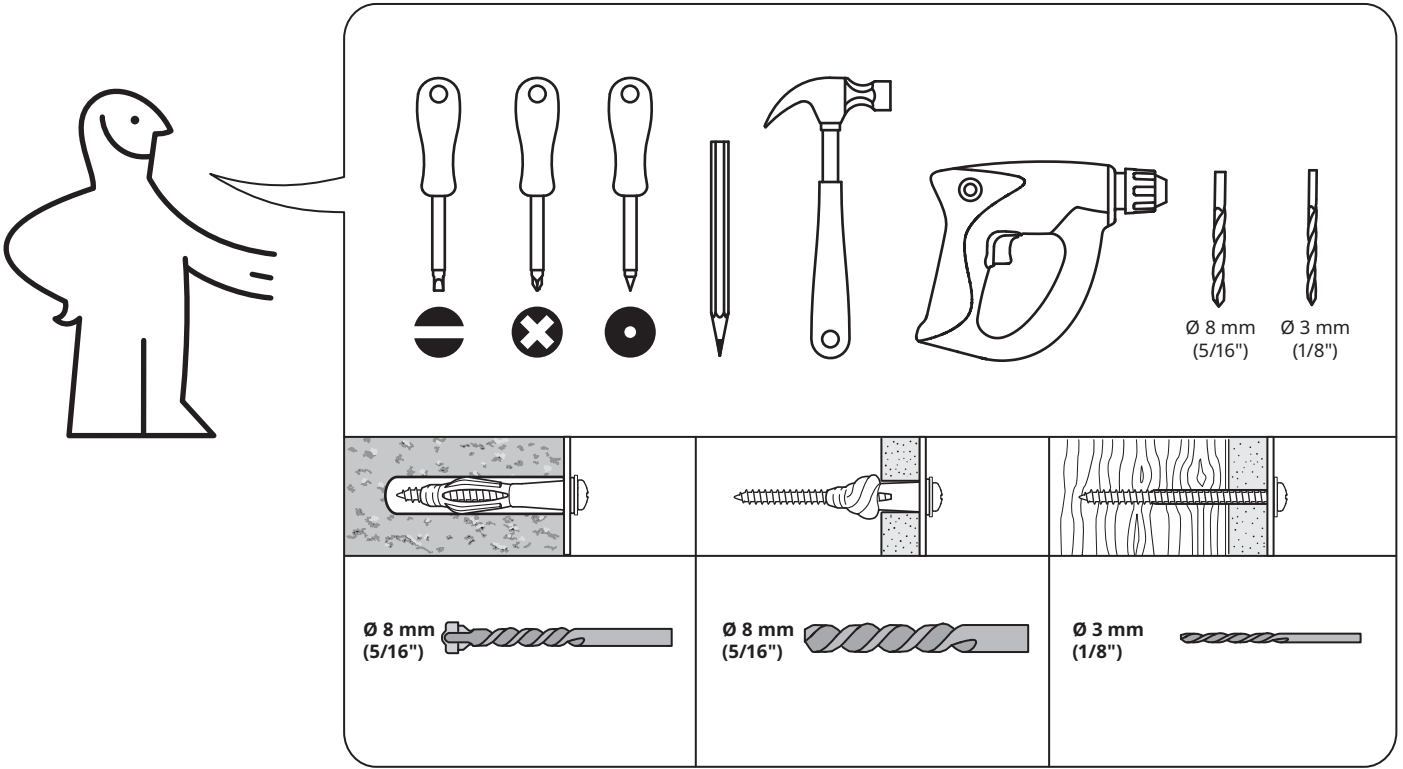

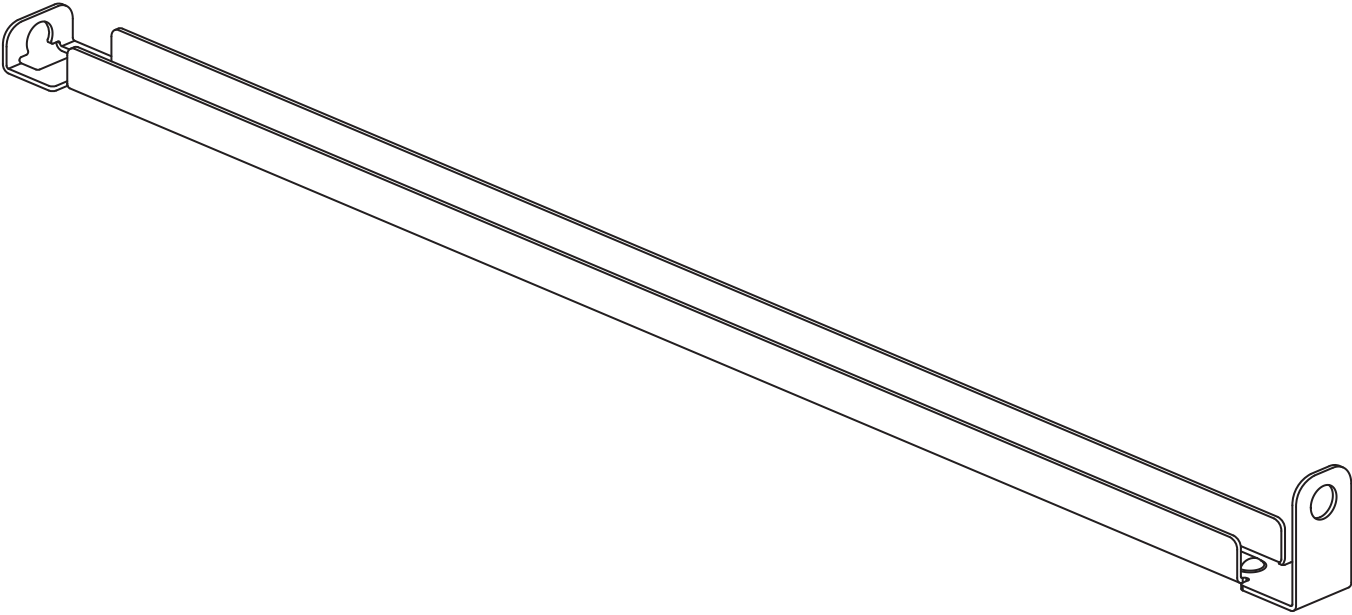
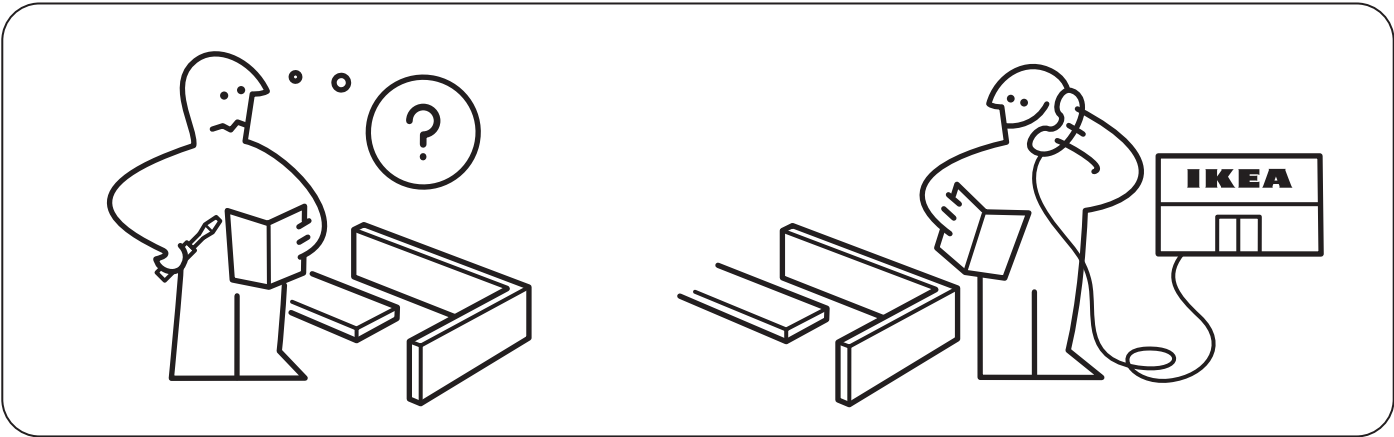
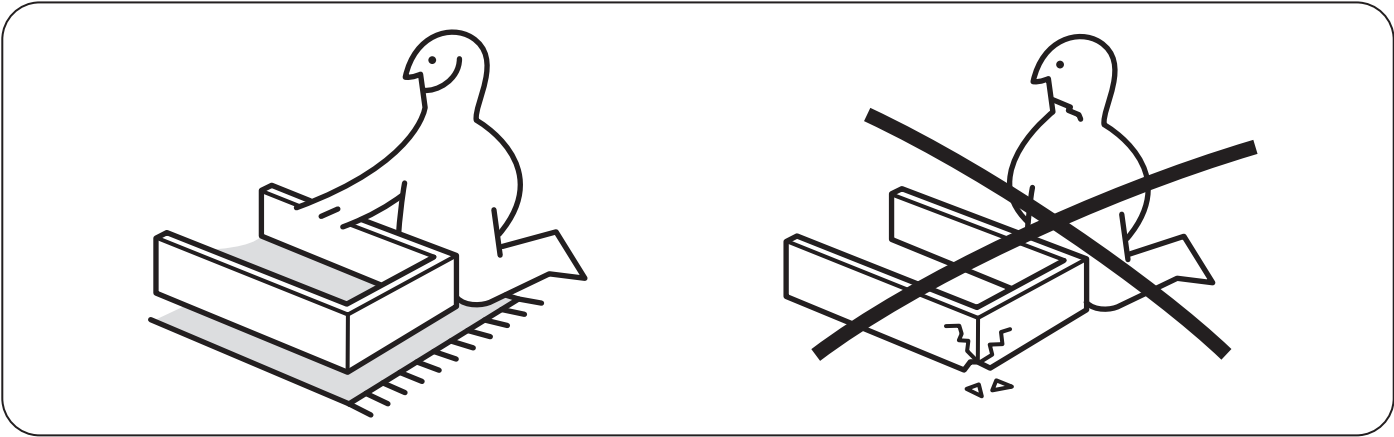

1x

152123

1

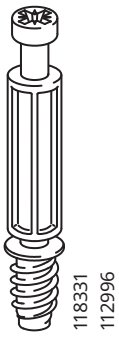

16x

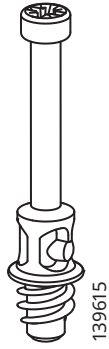

3x

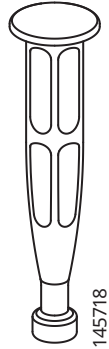

4x

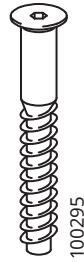

2x

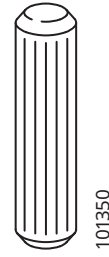

6x

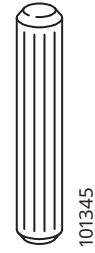

18x



2x



4x



6x

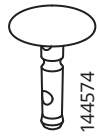

12x



12x

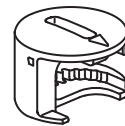

19x



4x

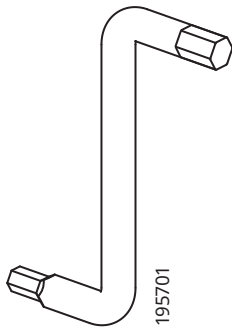

1x

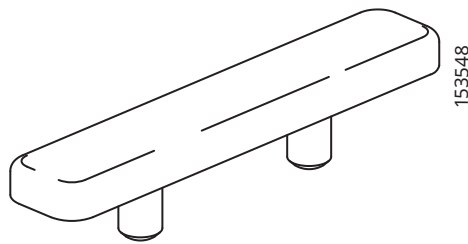

4x



1x



1x

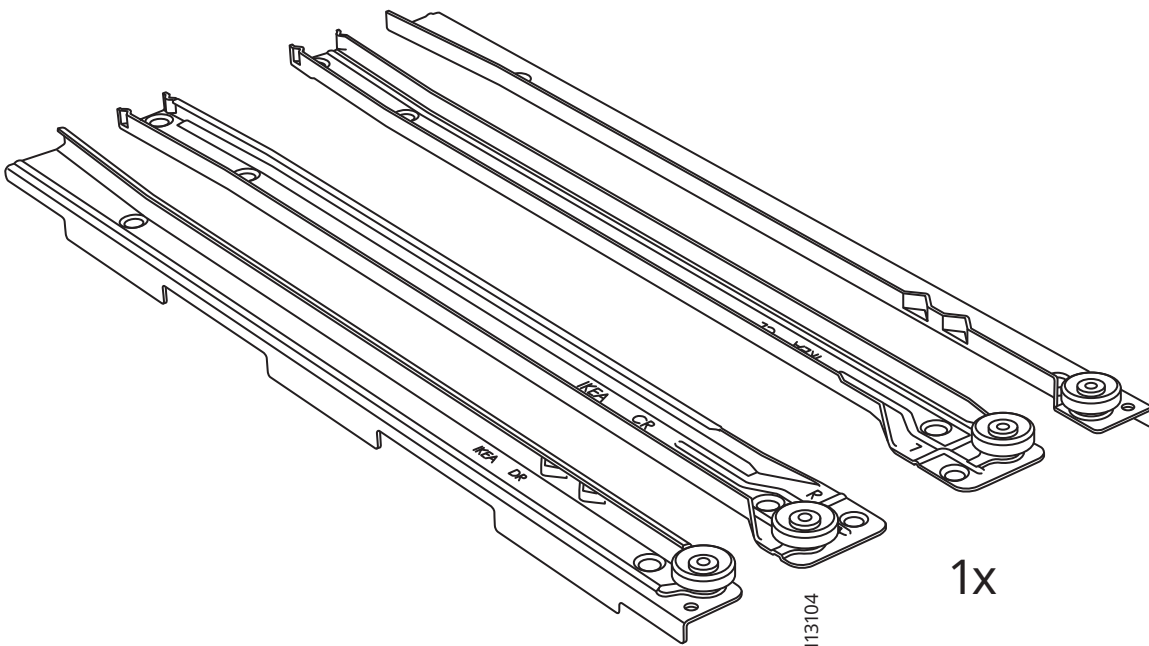

1x

2

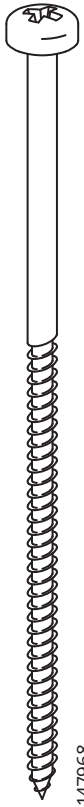

2x

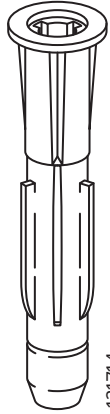

2x

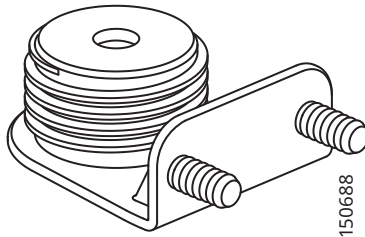

2x

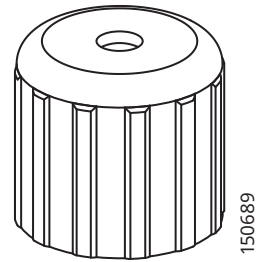

2x

1

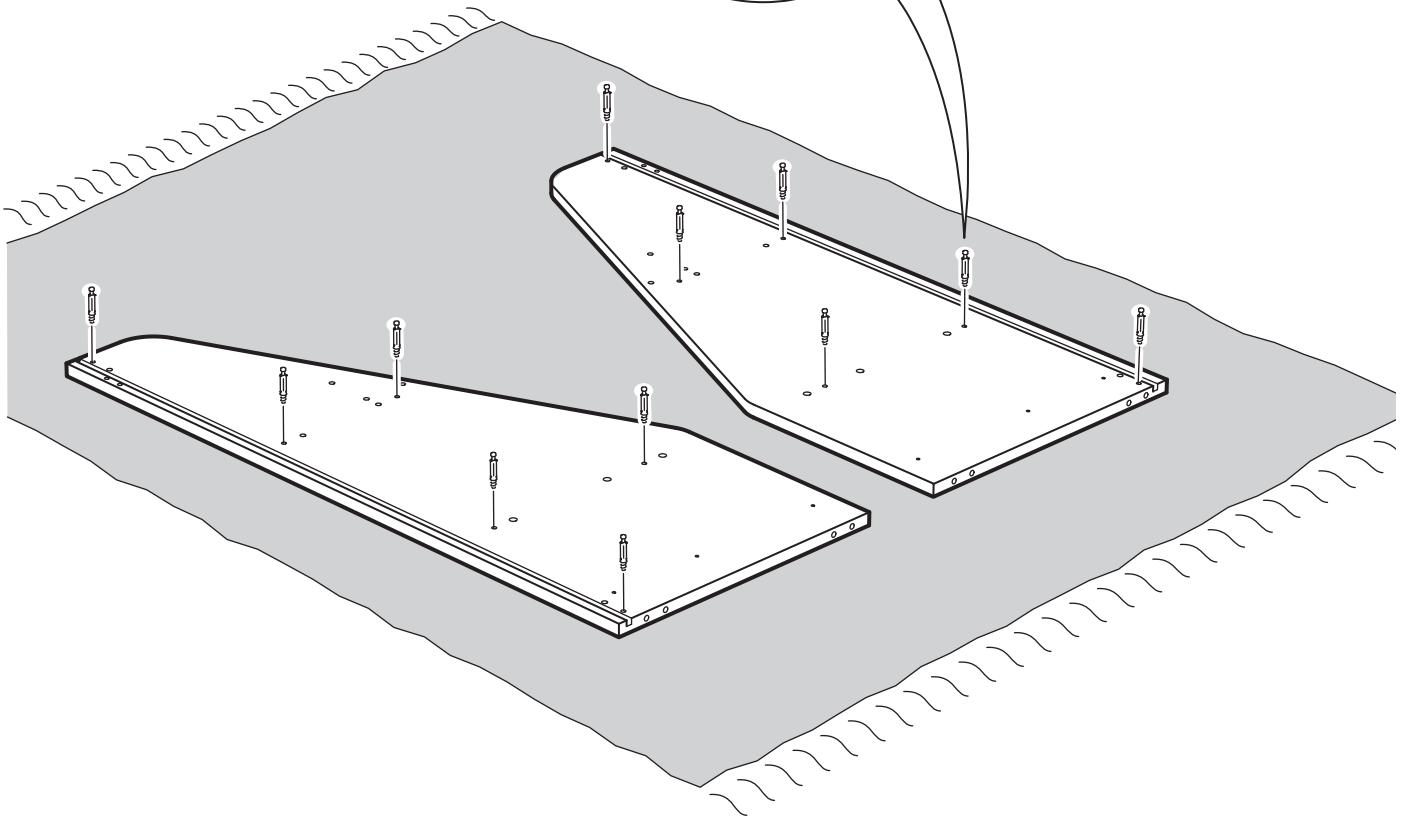
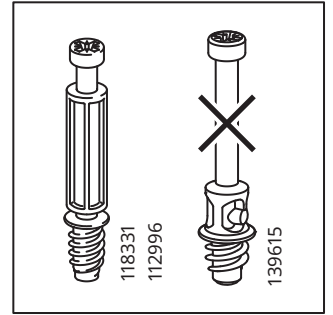
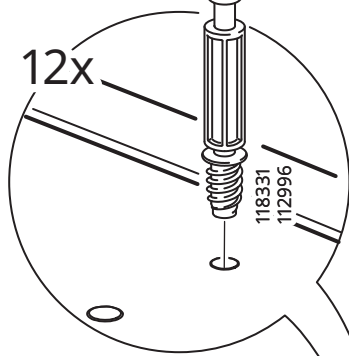
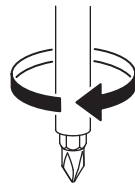

2

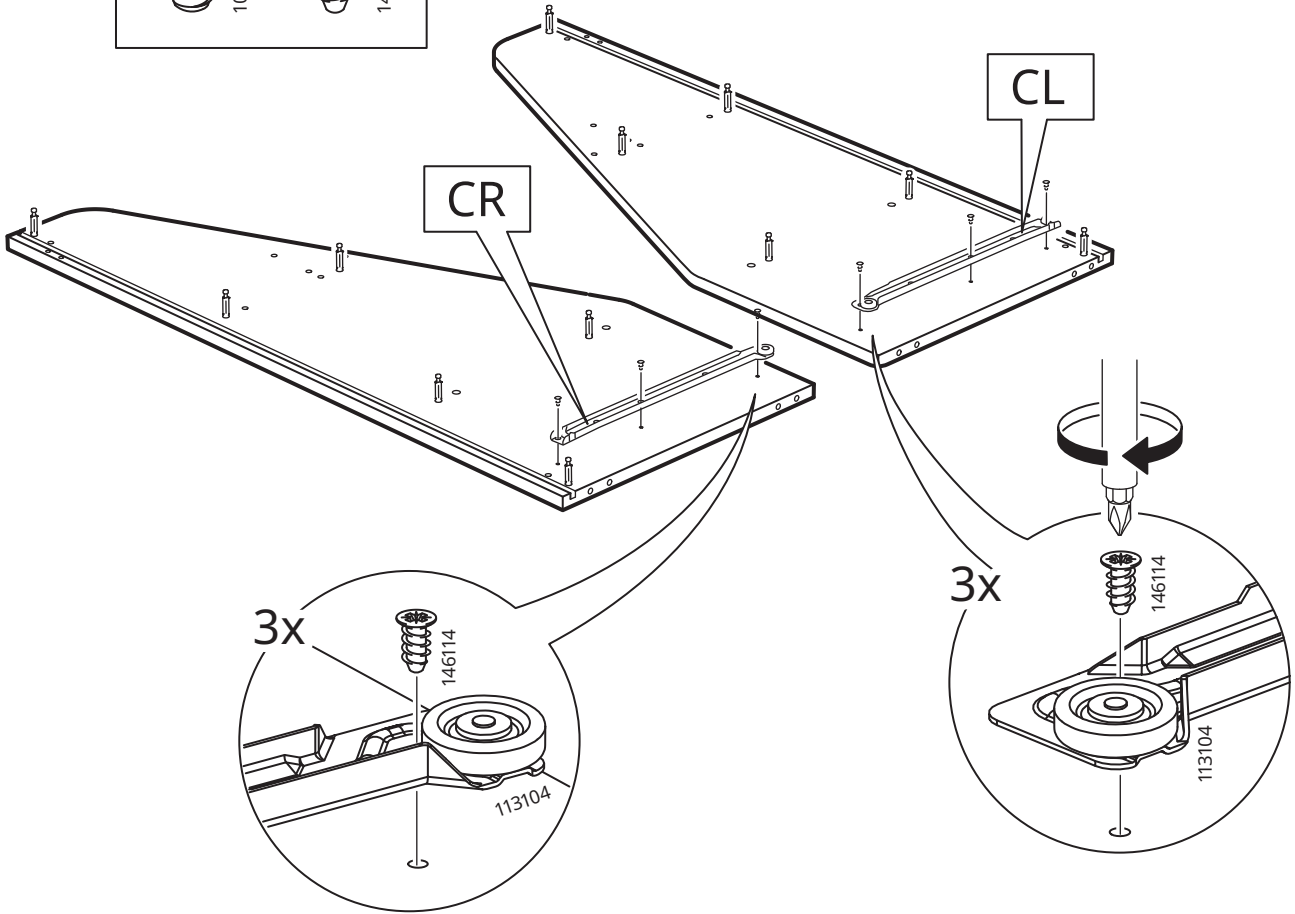
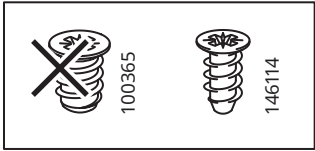

3

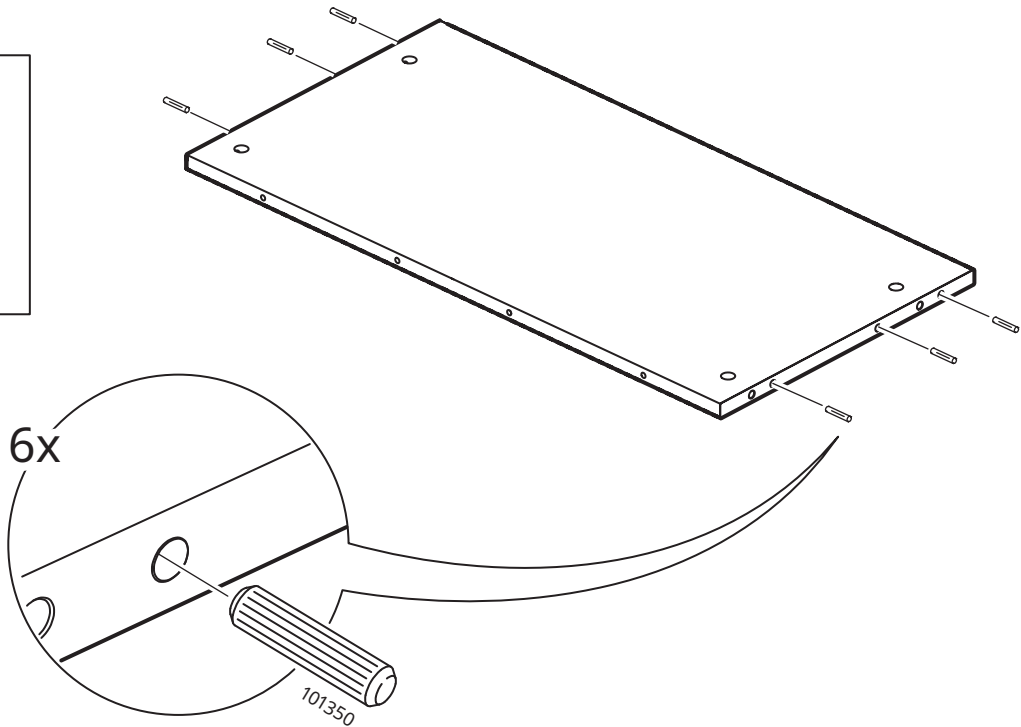
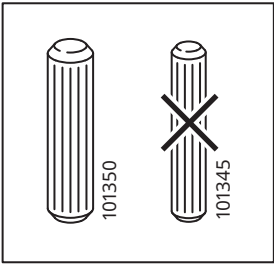

4

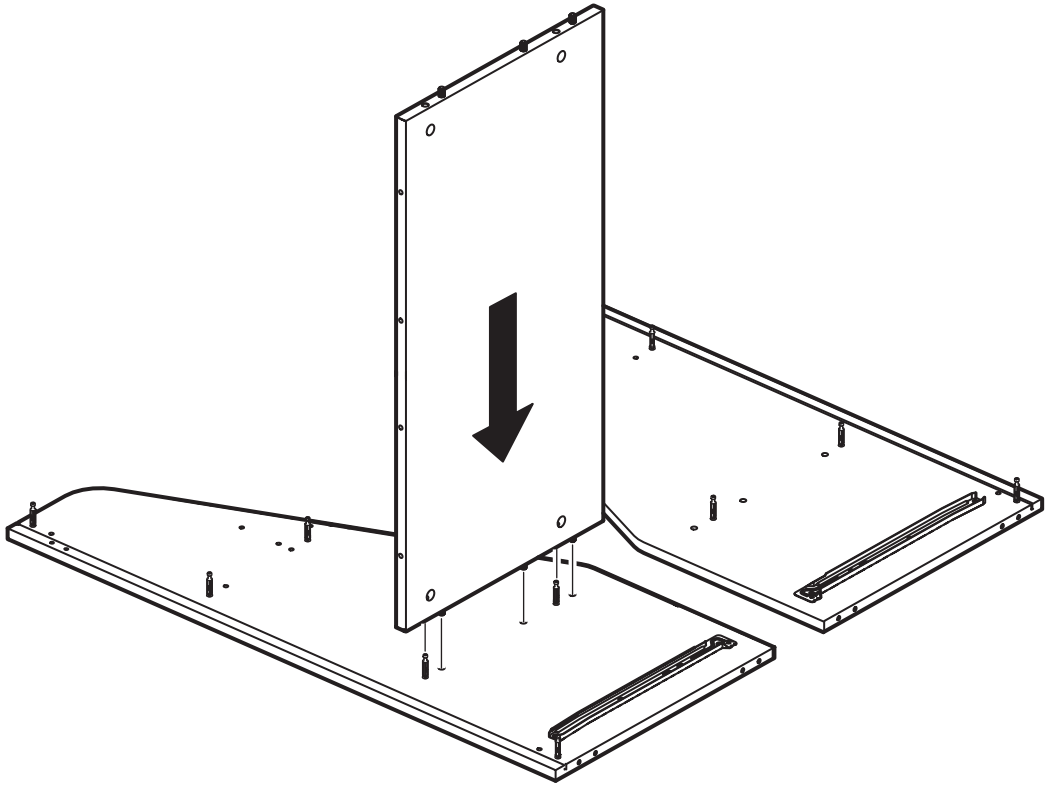

5

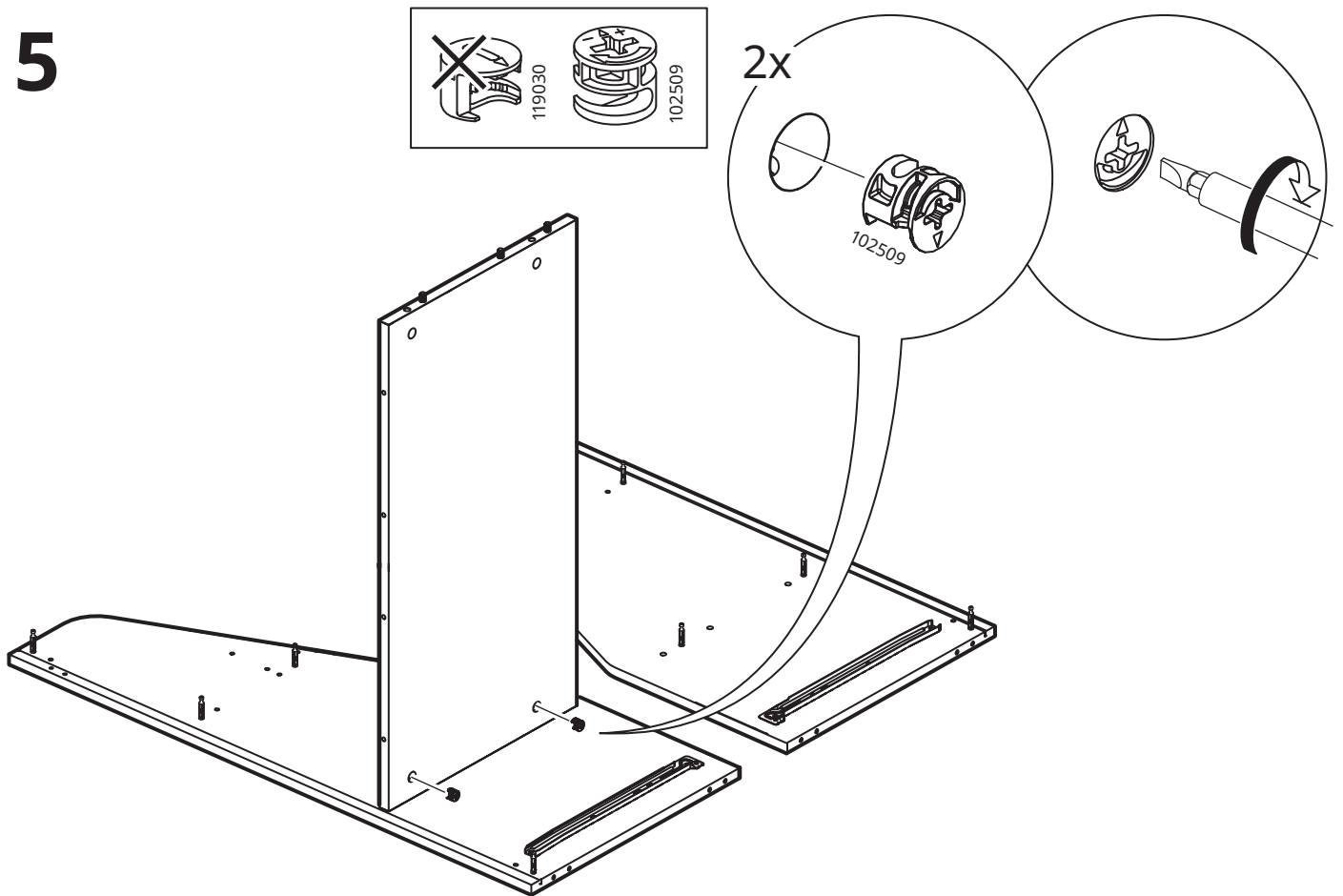

6

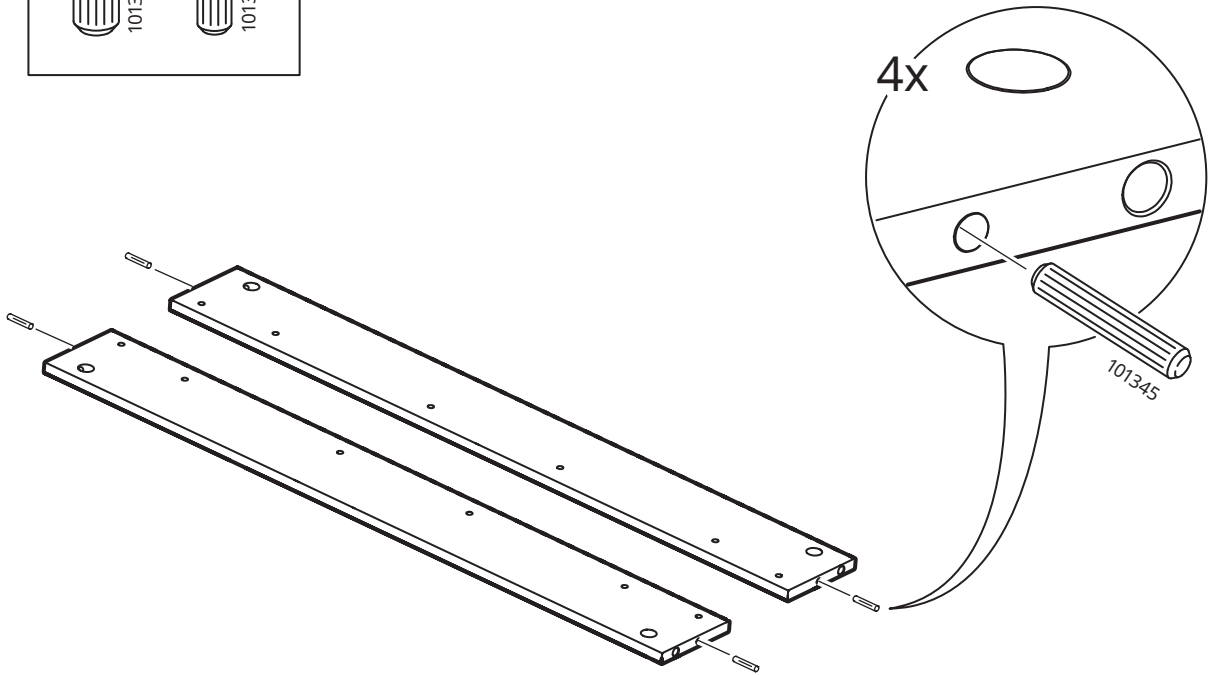
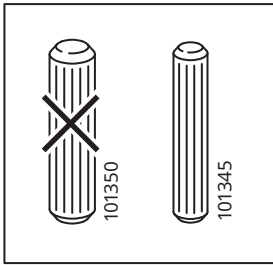

7

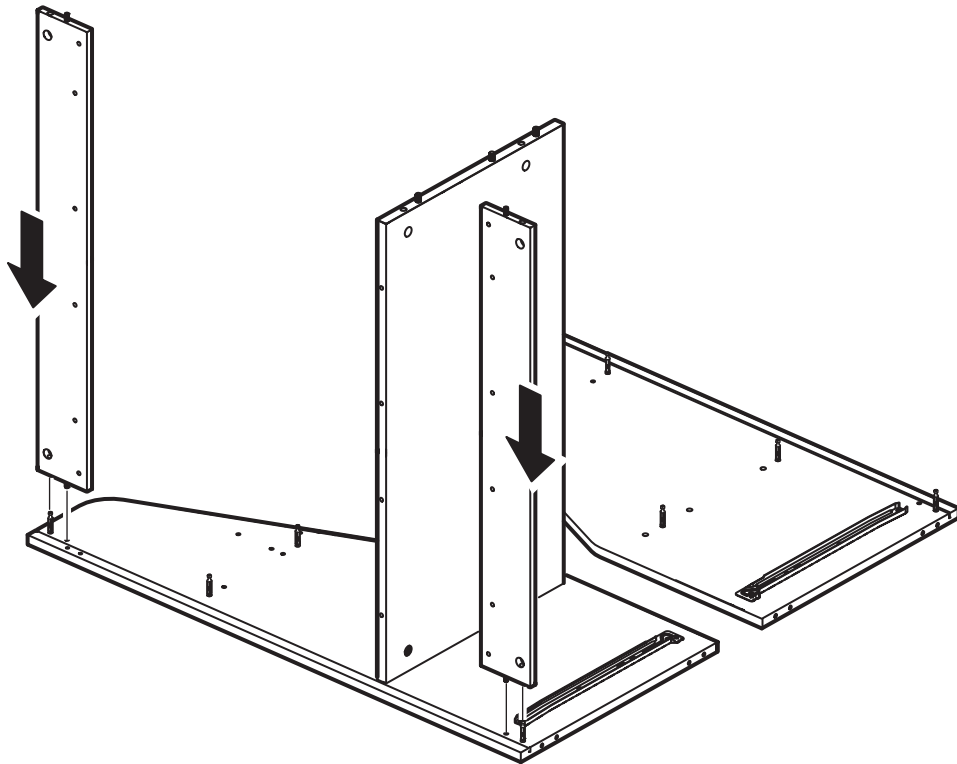

8

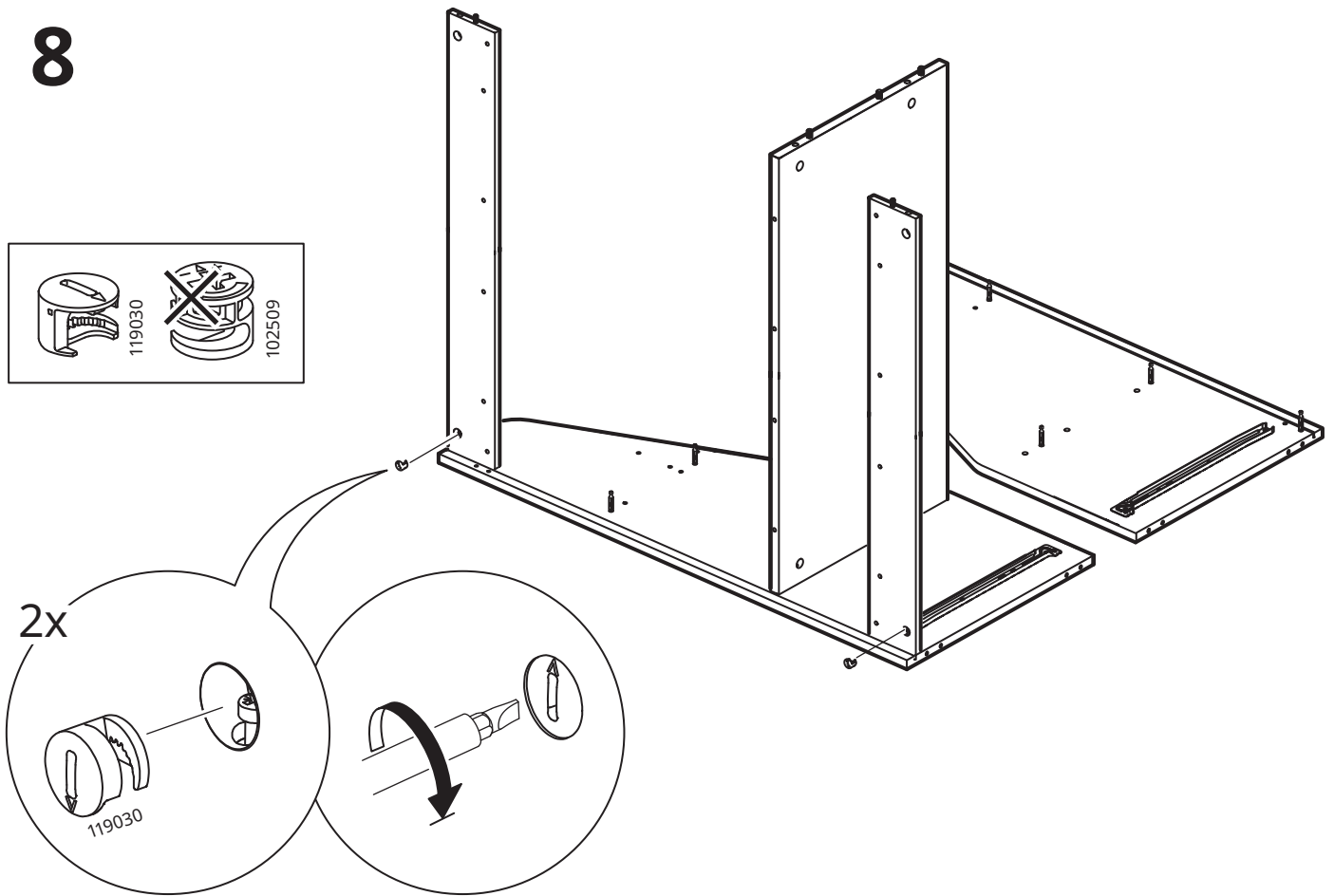

9

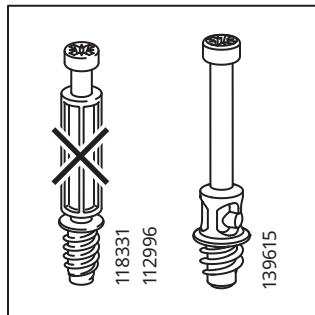

10

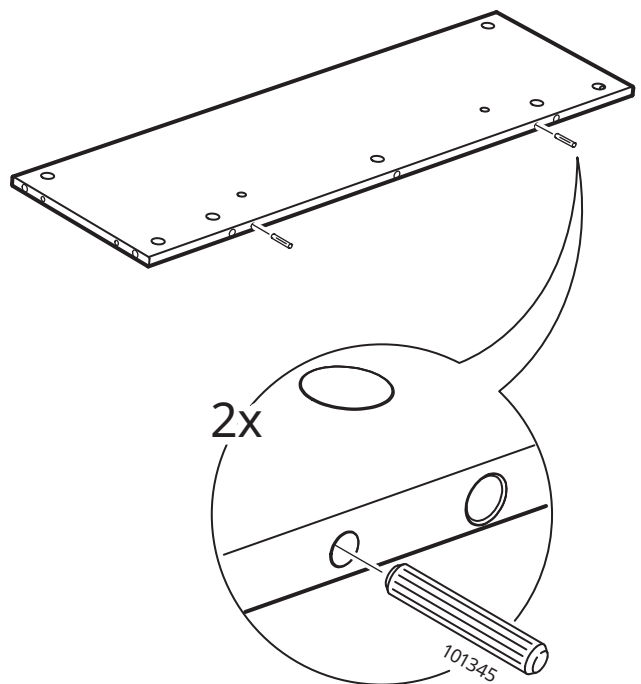
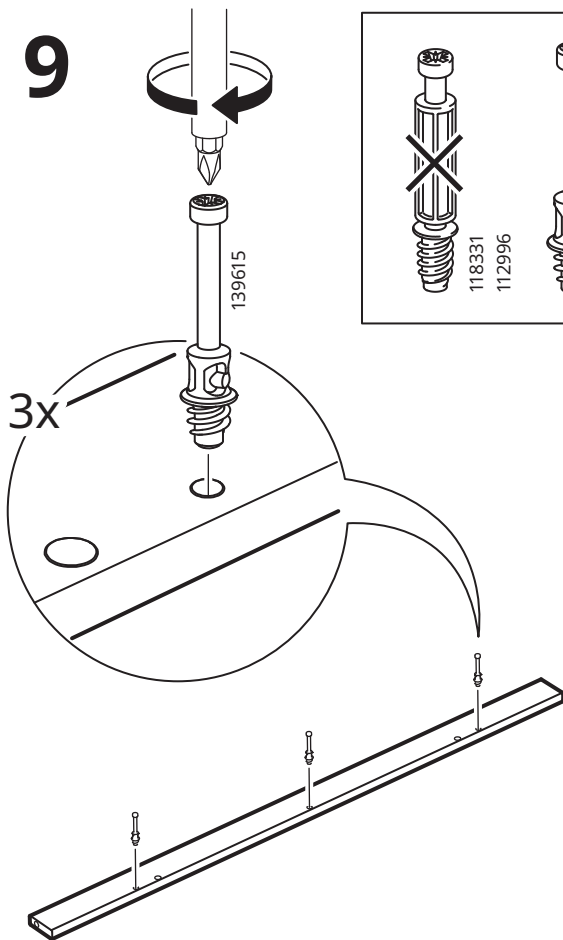

11

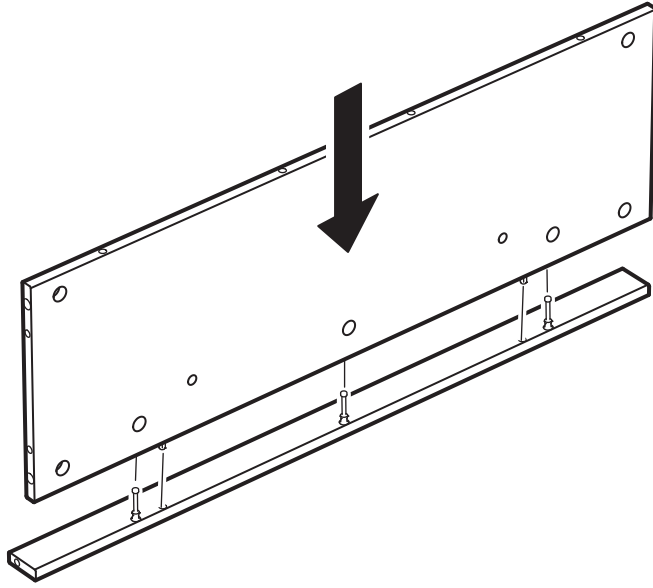

12

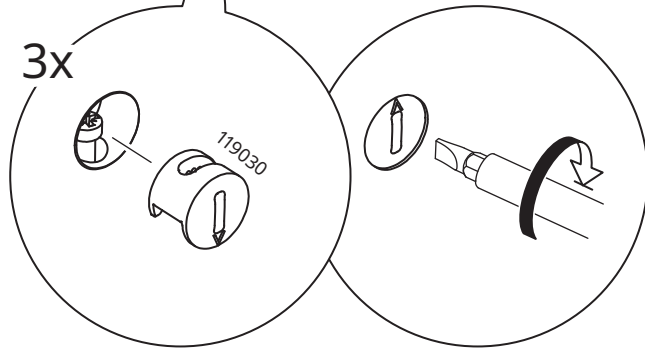
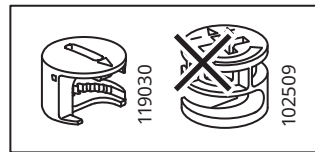
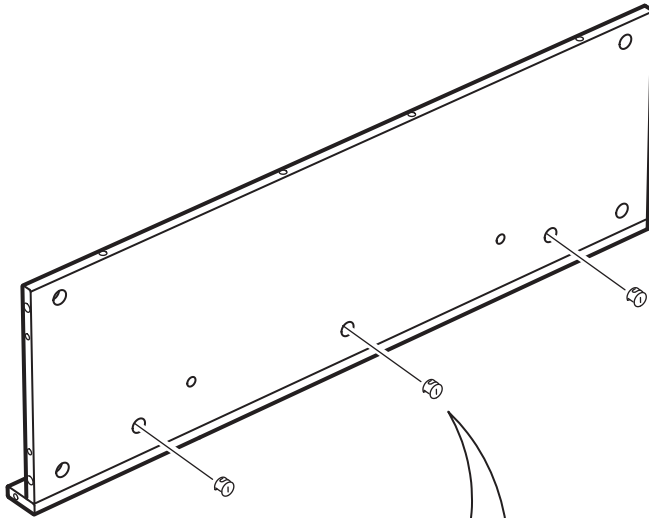

13

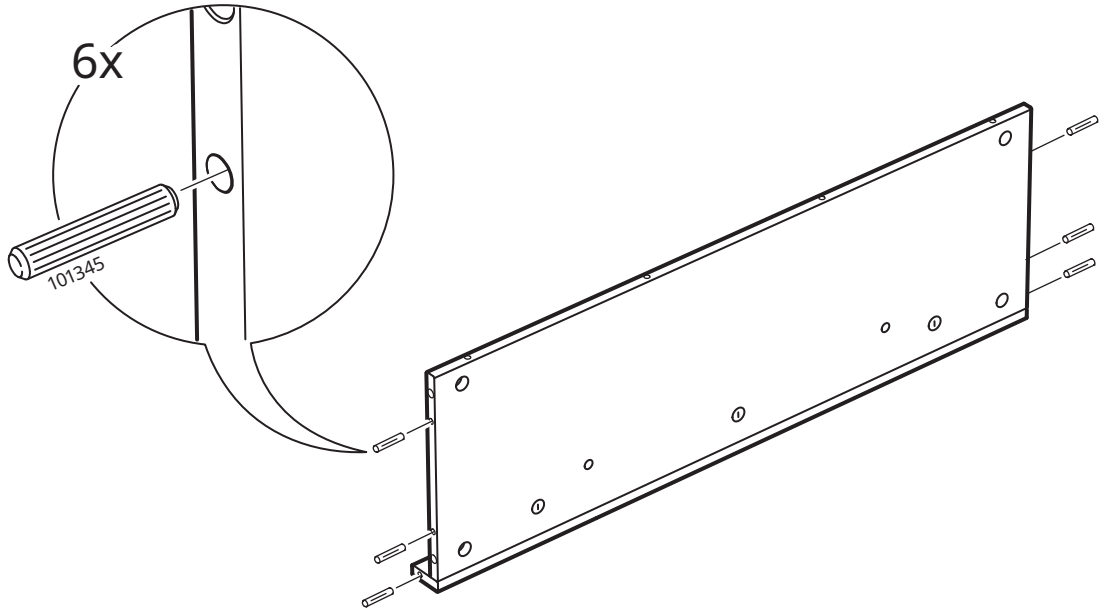

14

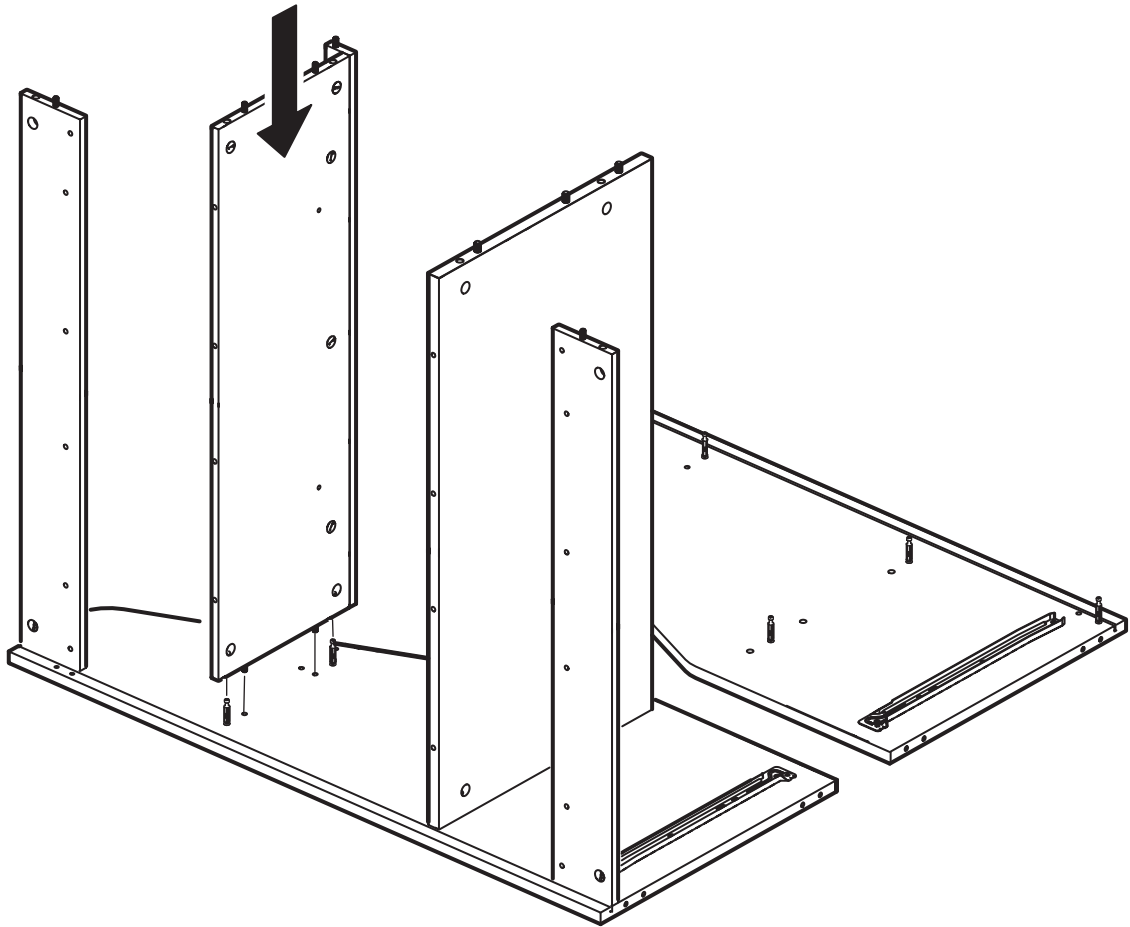

15

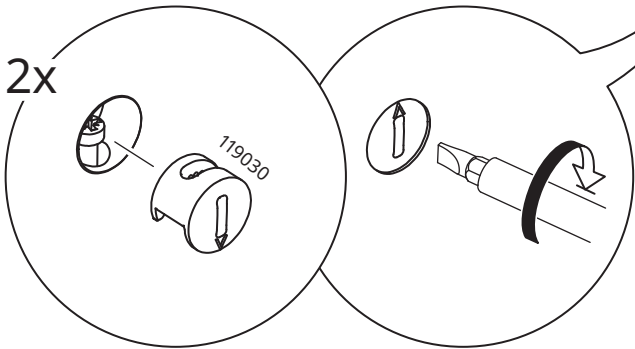
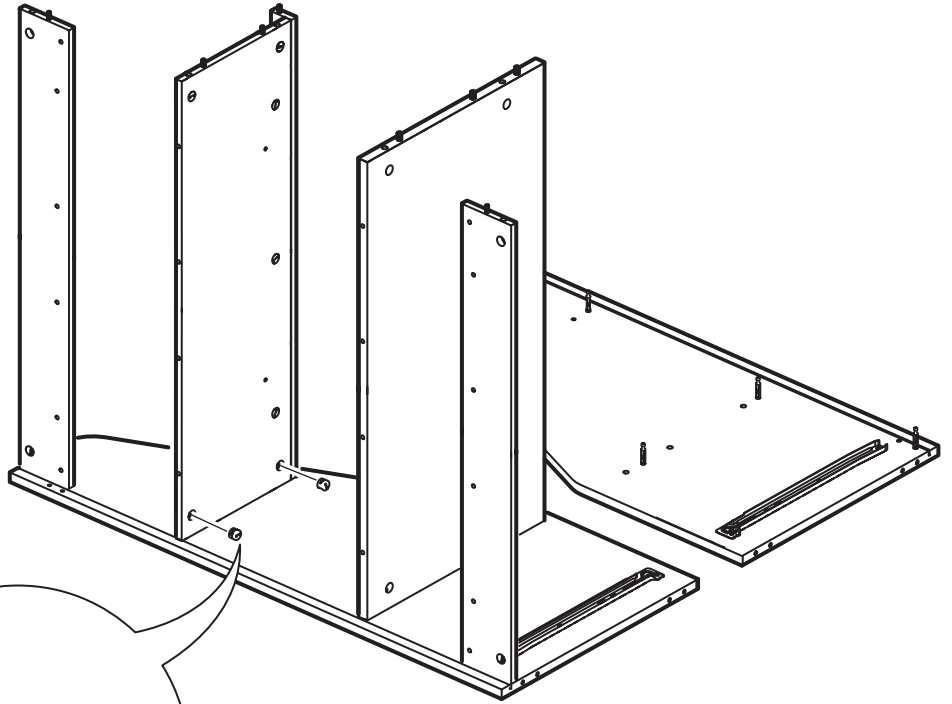

2x

16

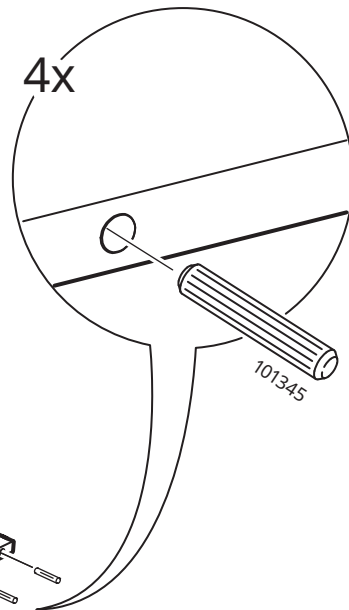
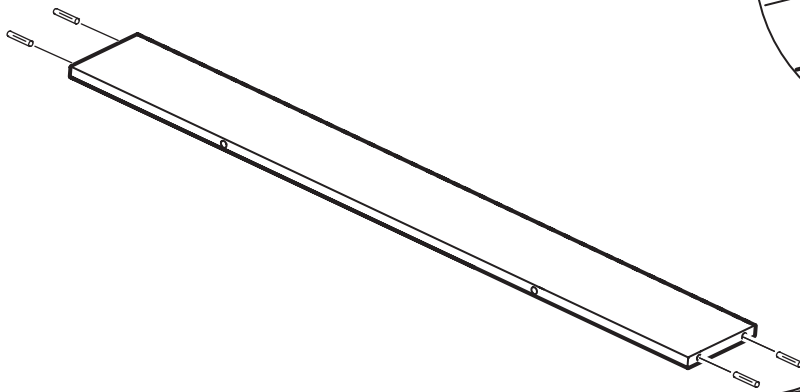
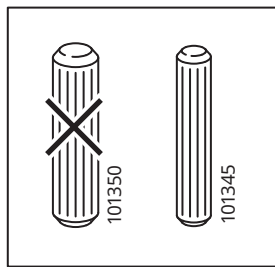

4x

17

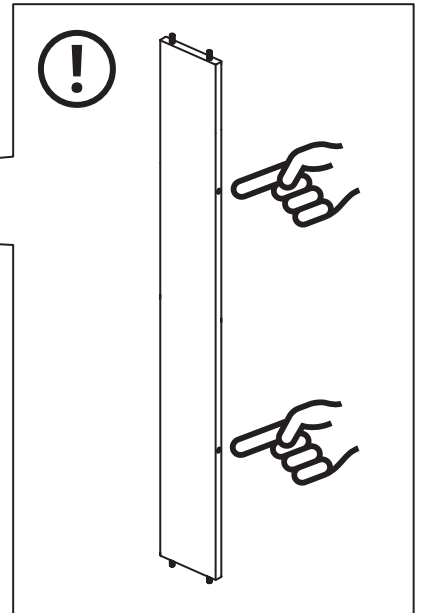
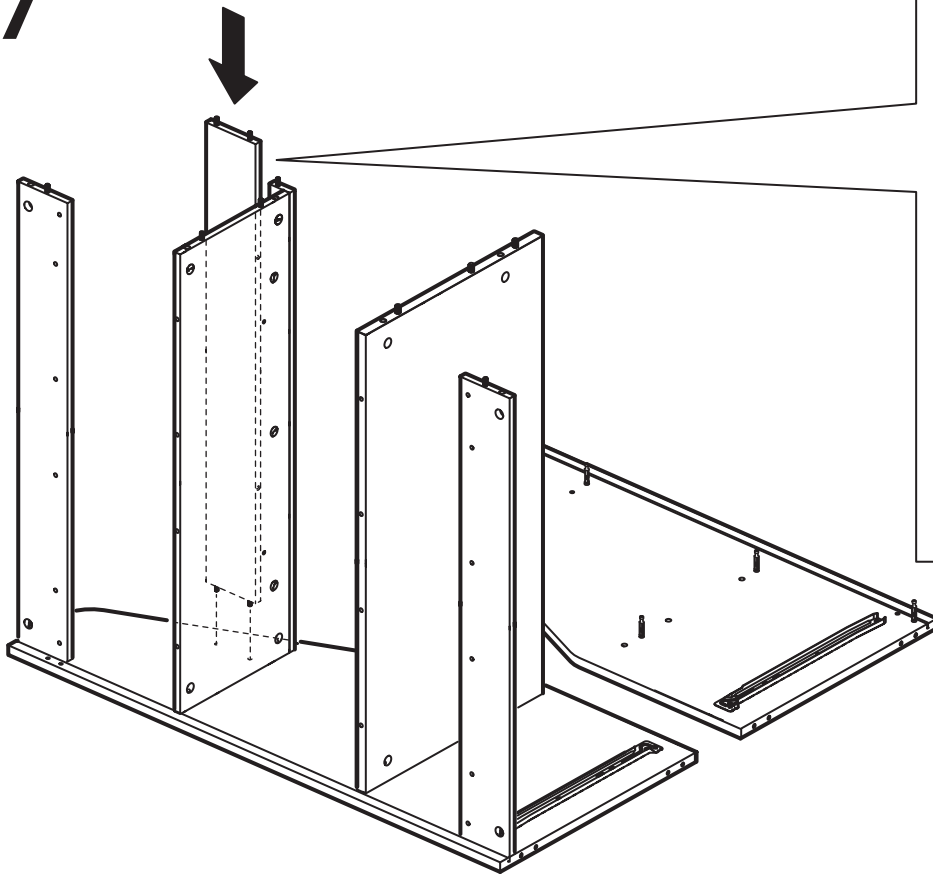

18

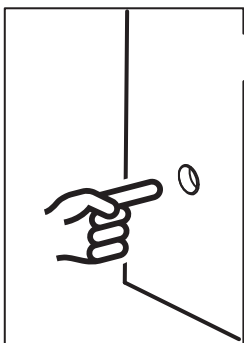
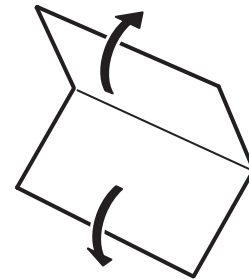
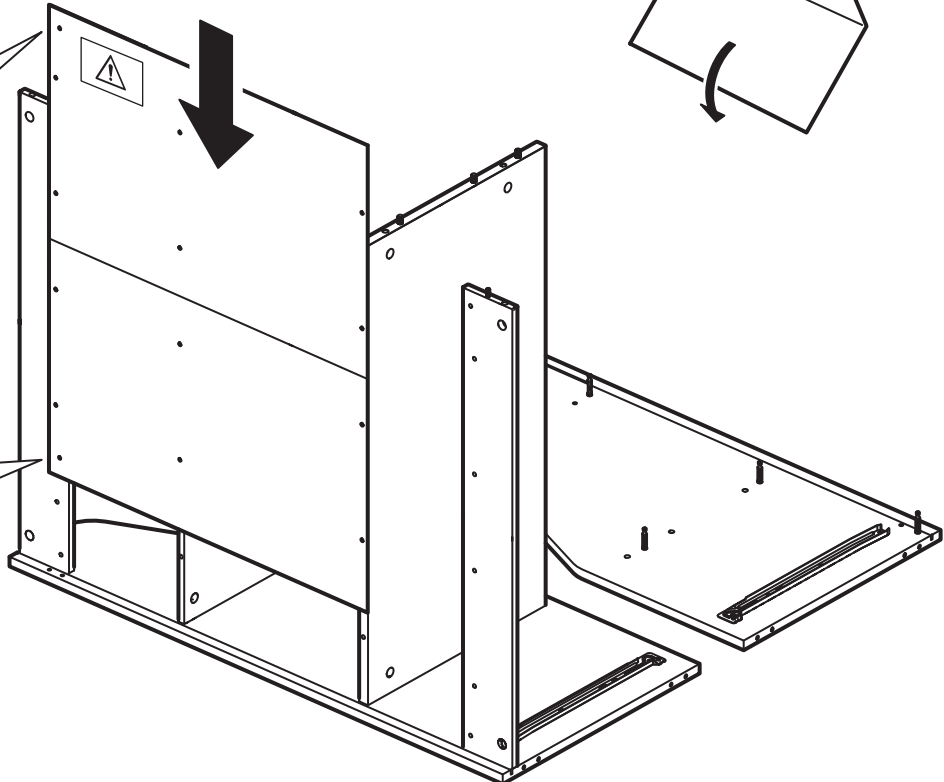
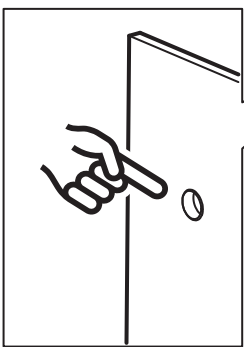

19

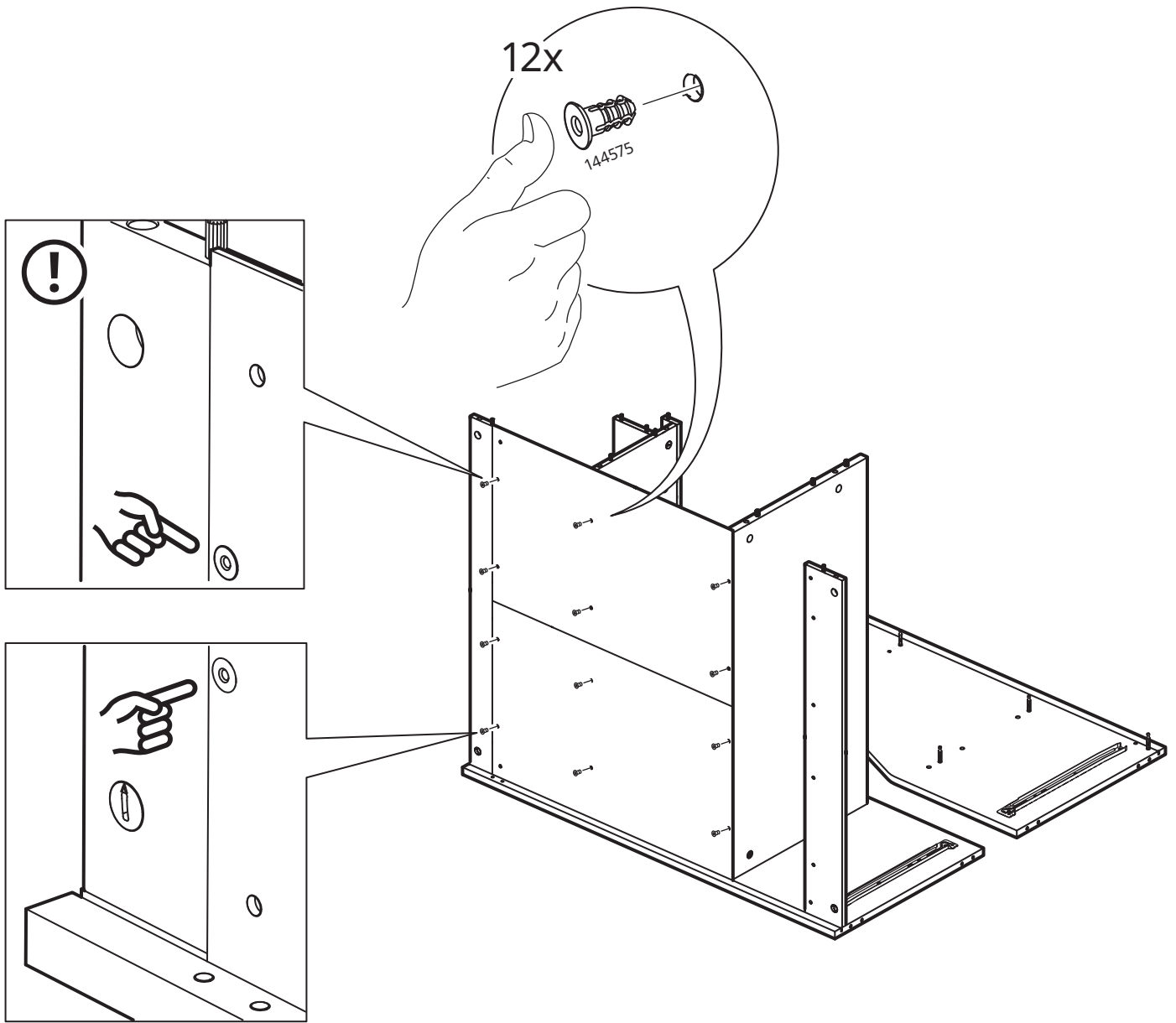

20

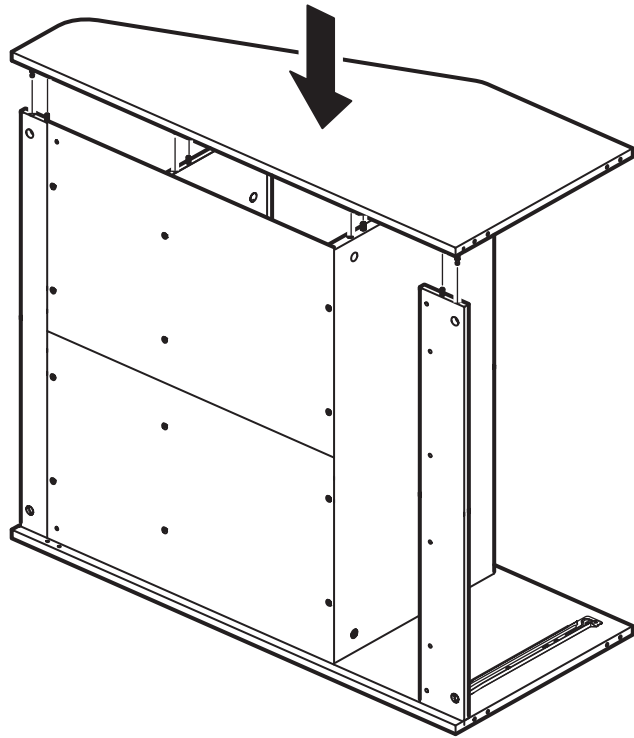

21

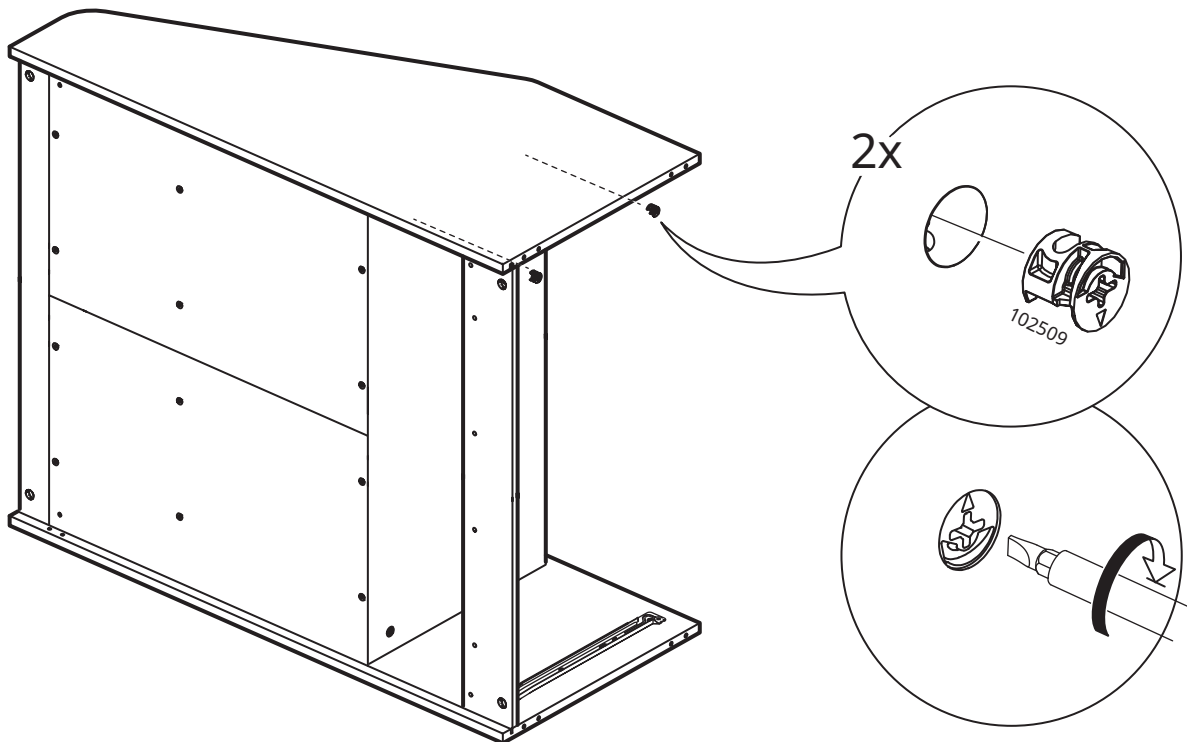
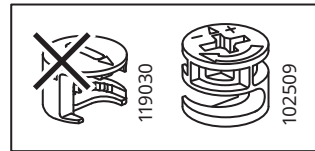

22

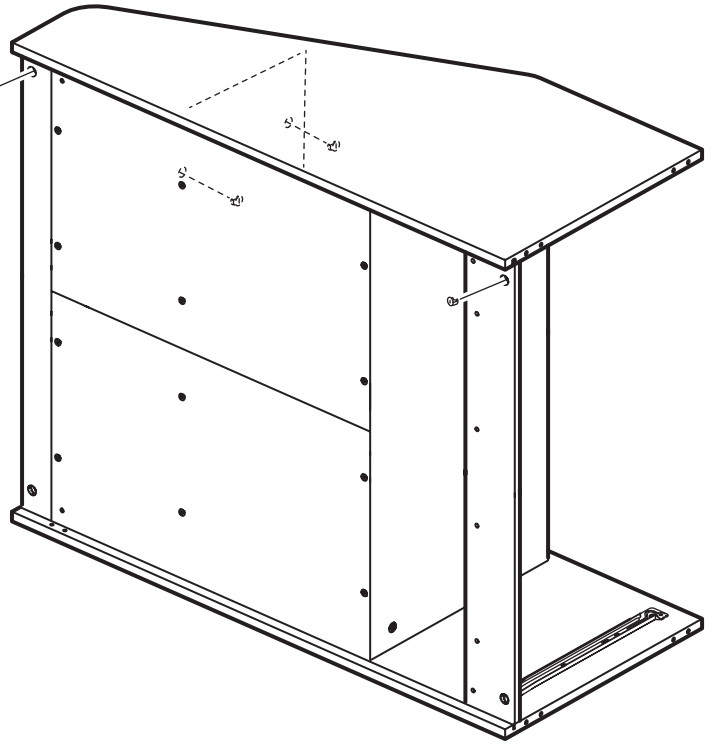
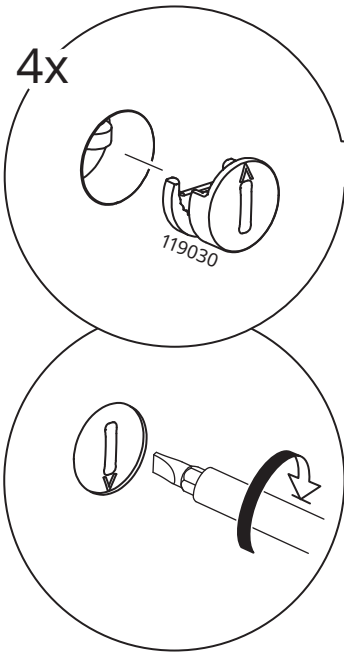

23

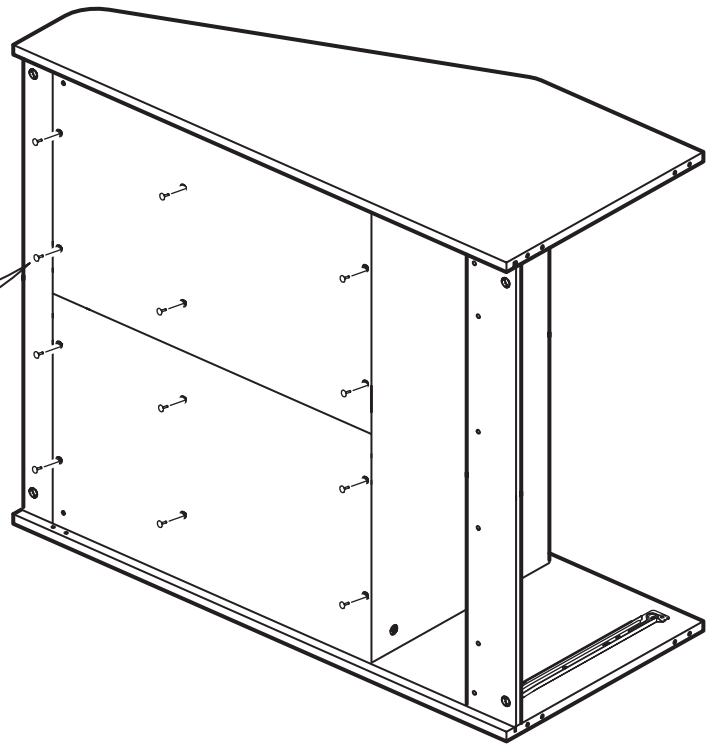
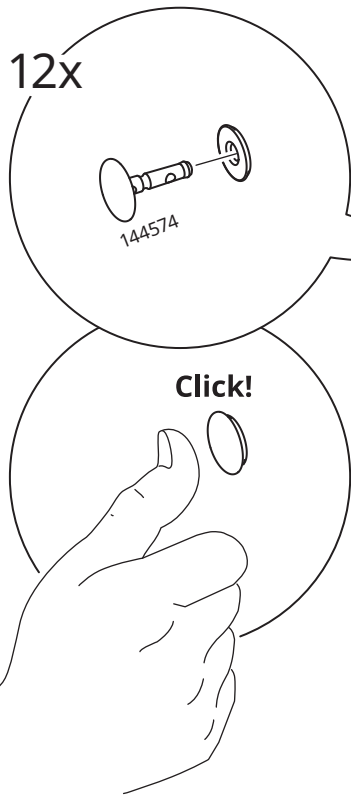

24

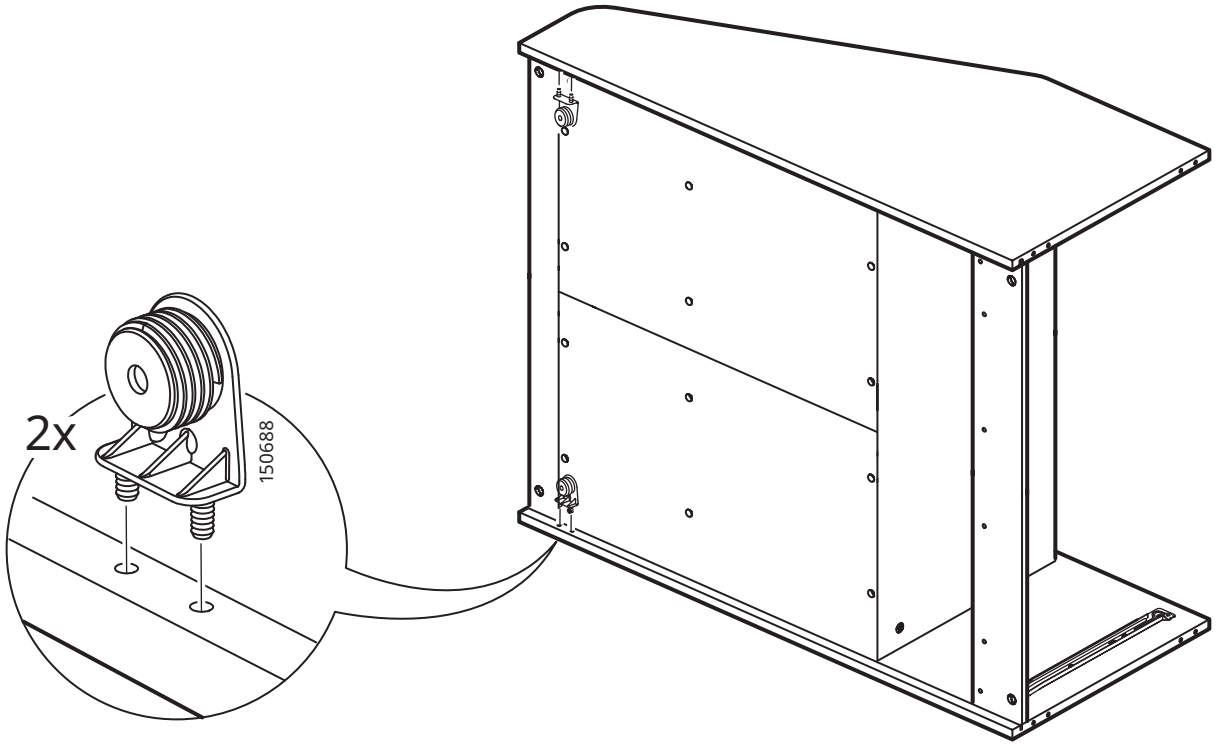

25

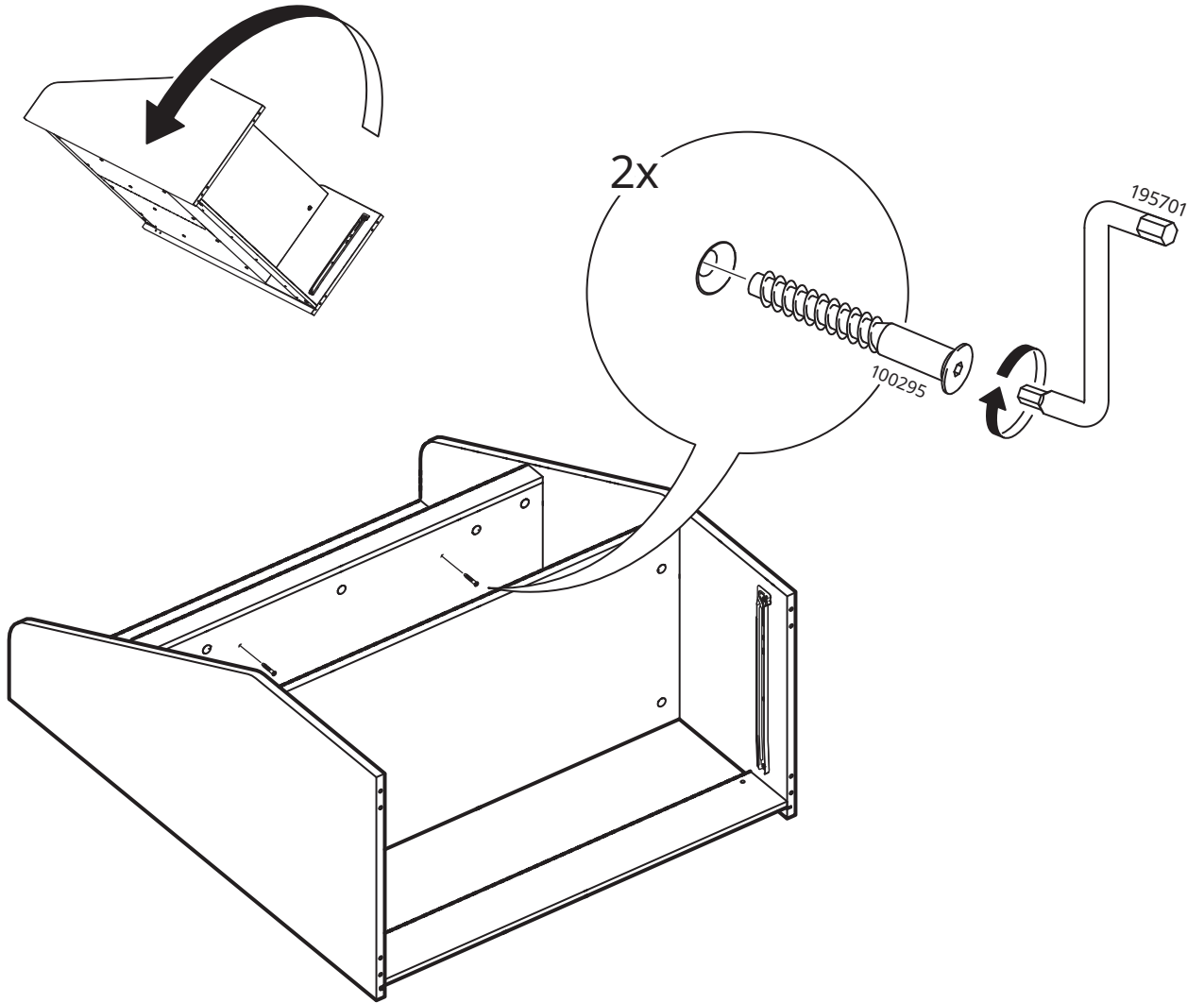

26

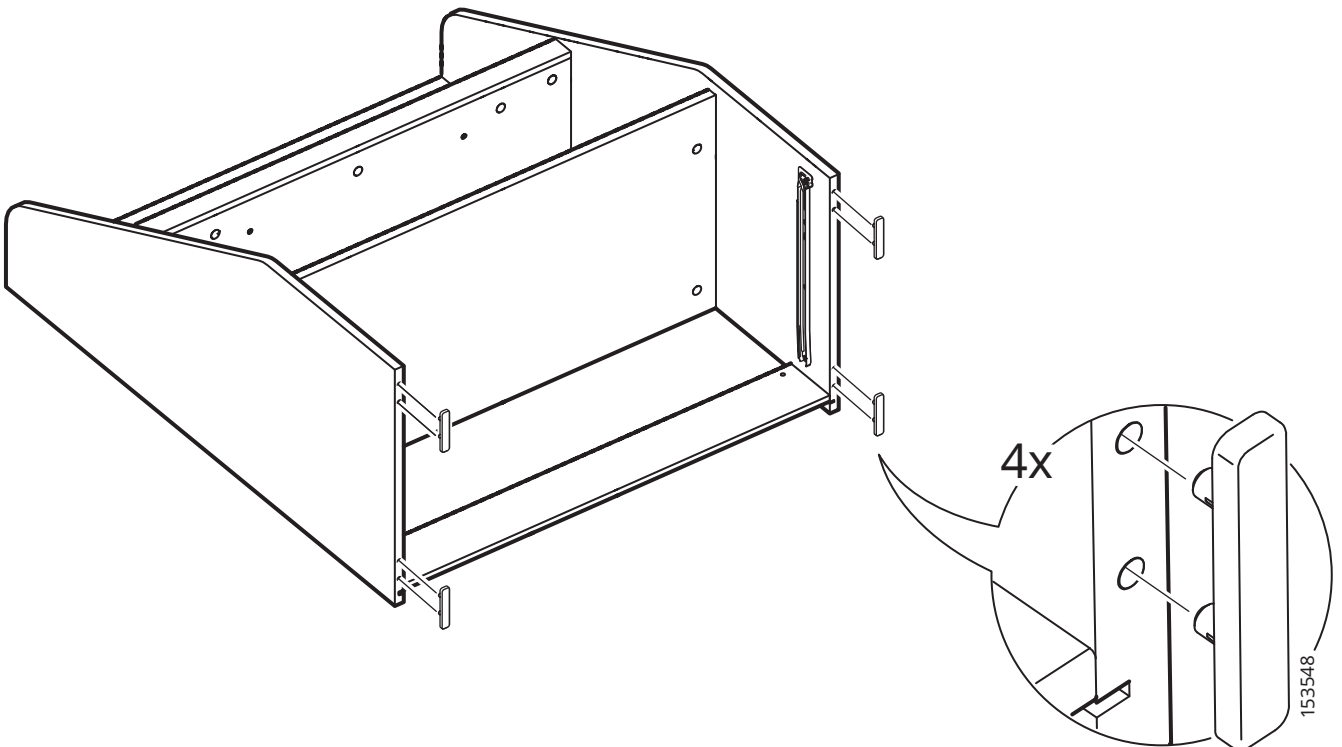

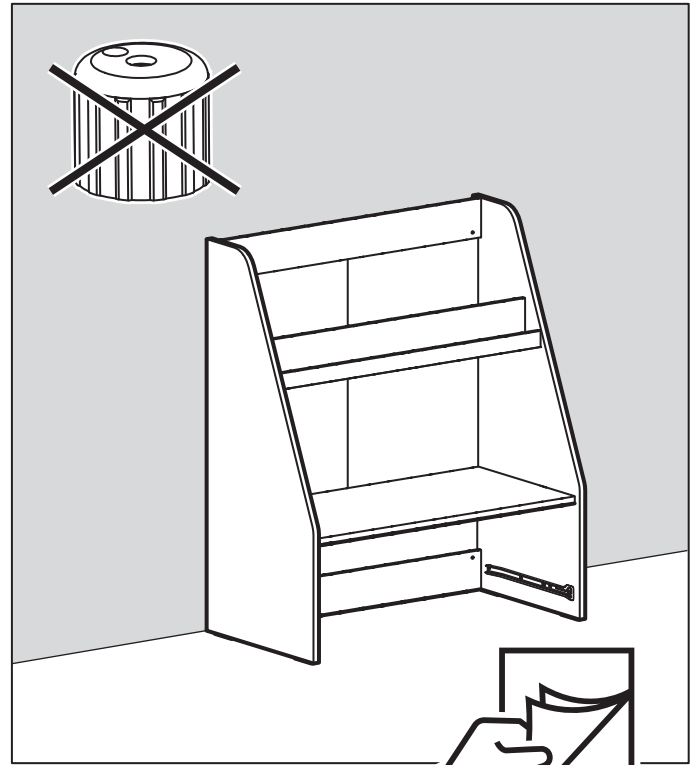
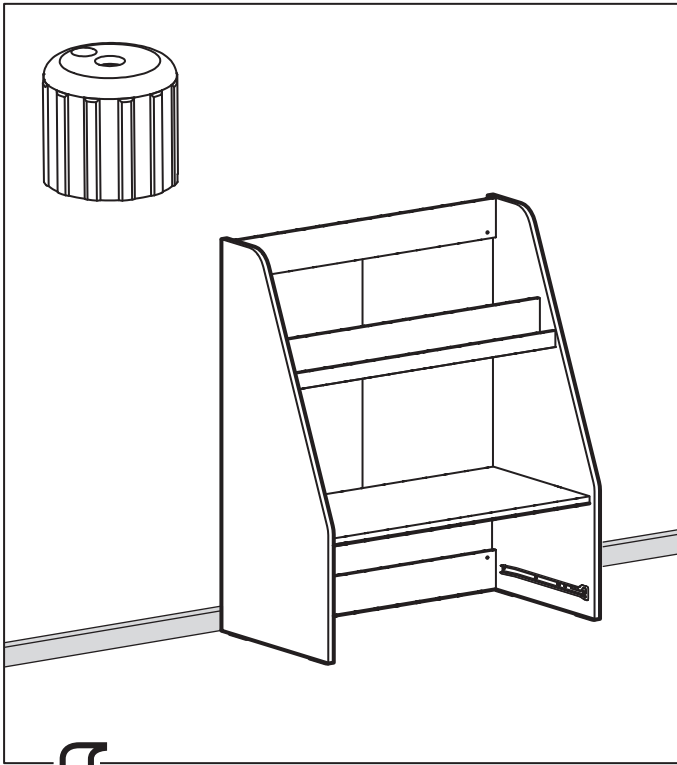

27

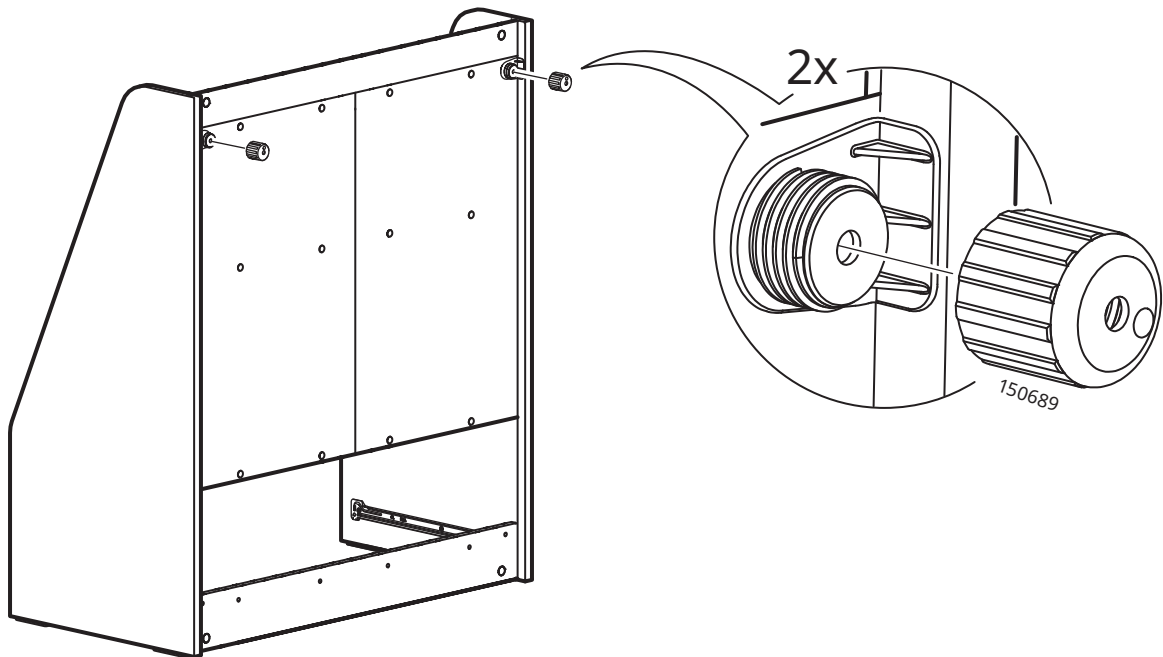

28

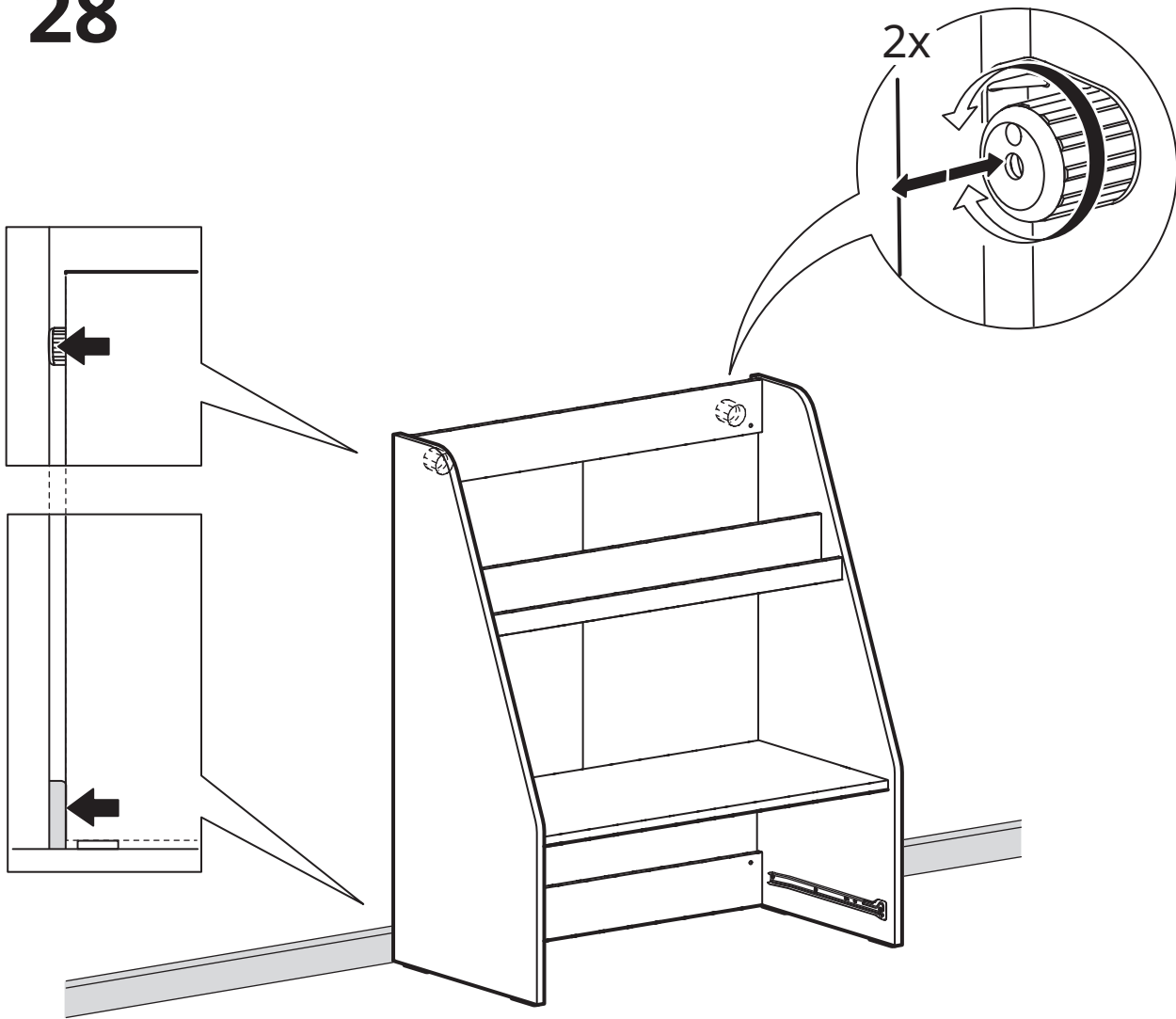

29

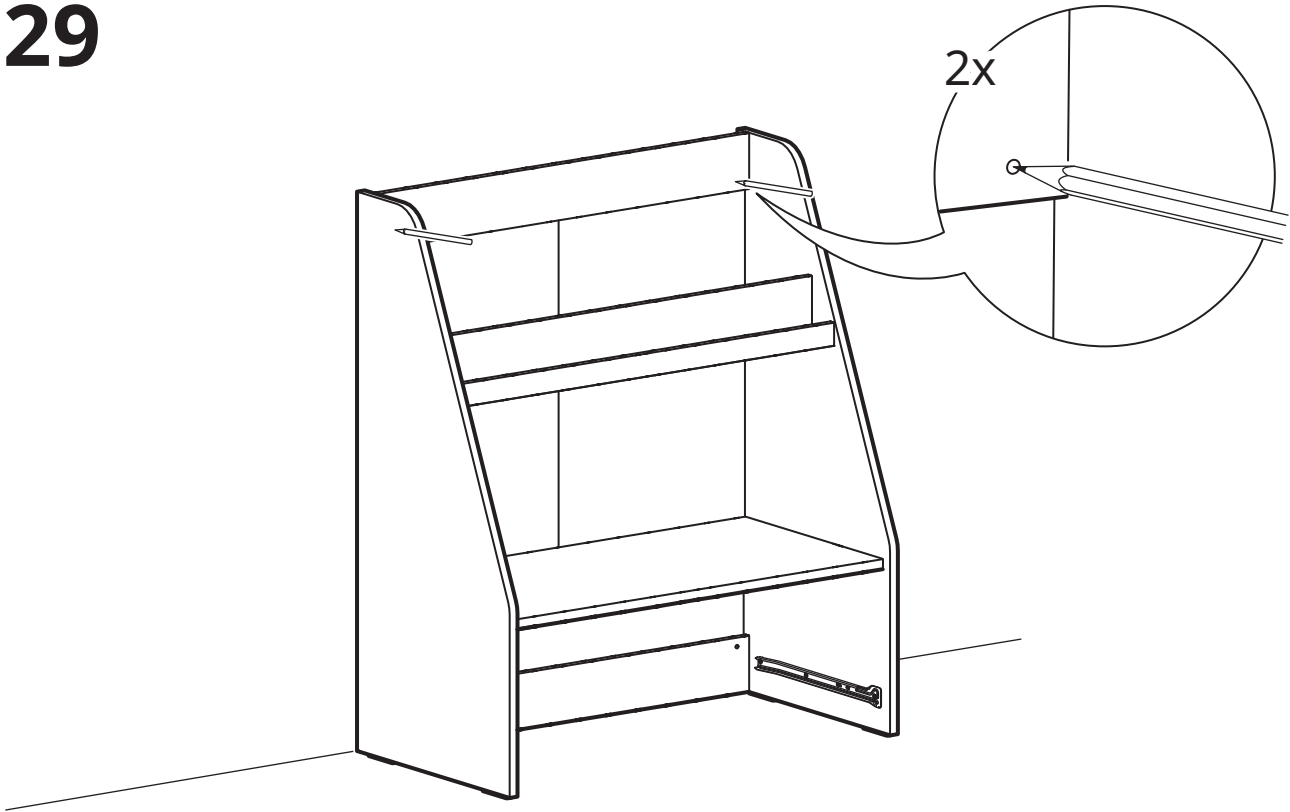

30

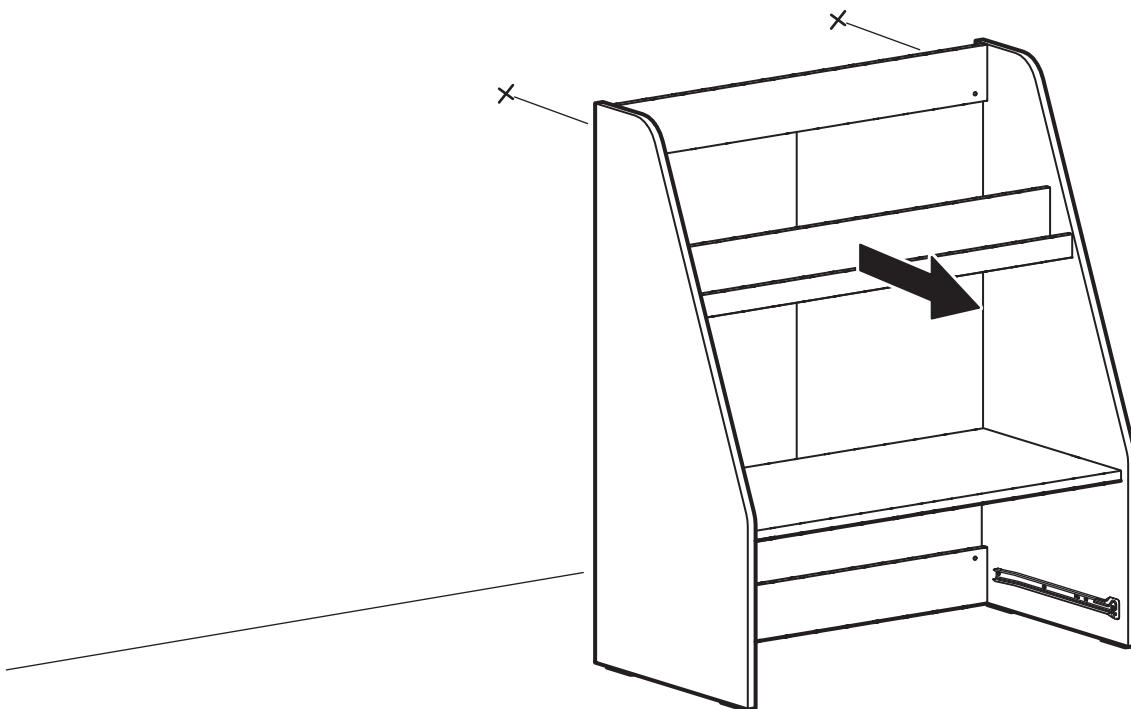

31

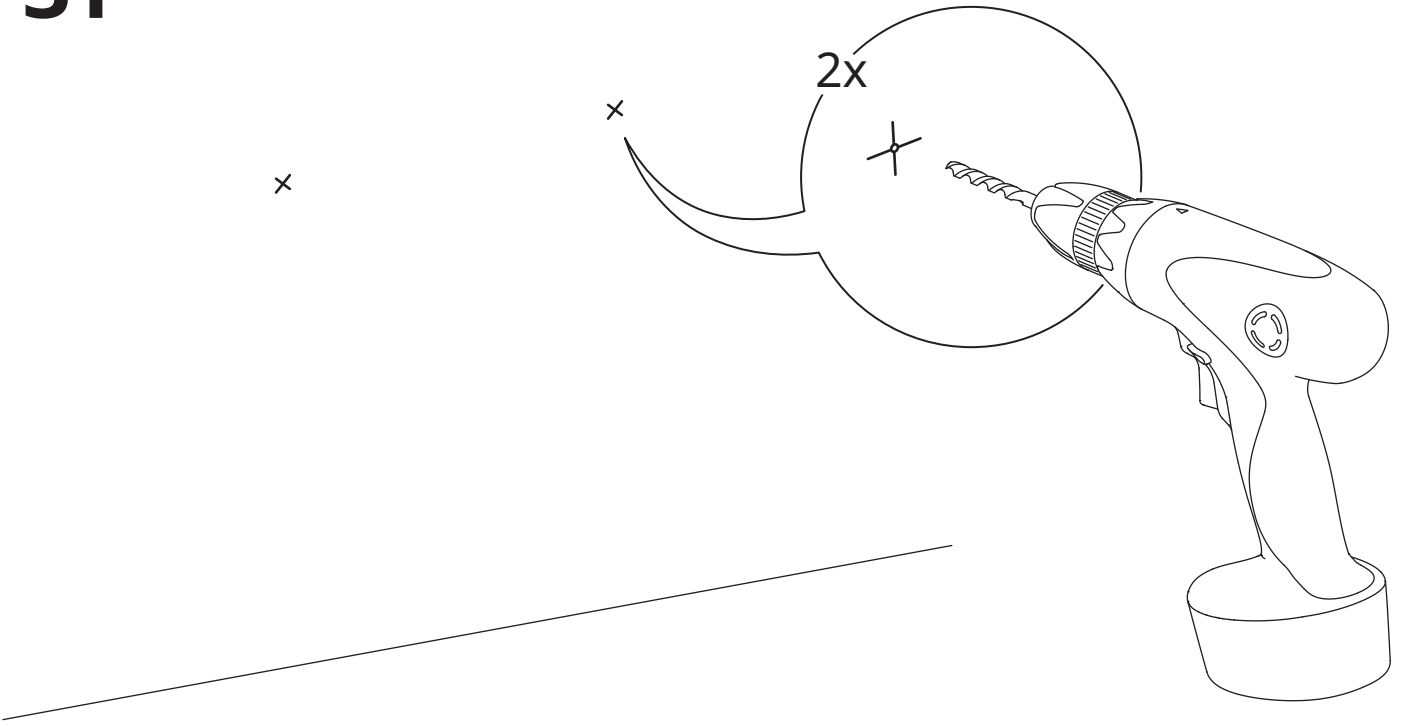

32

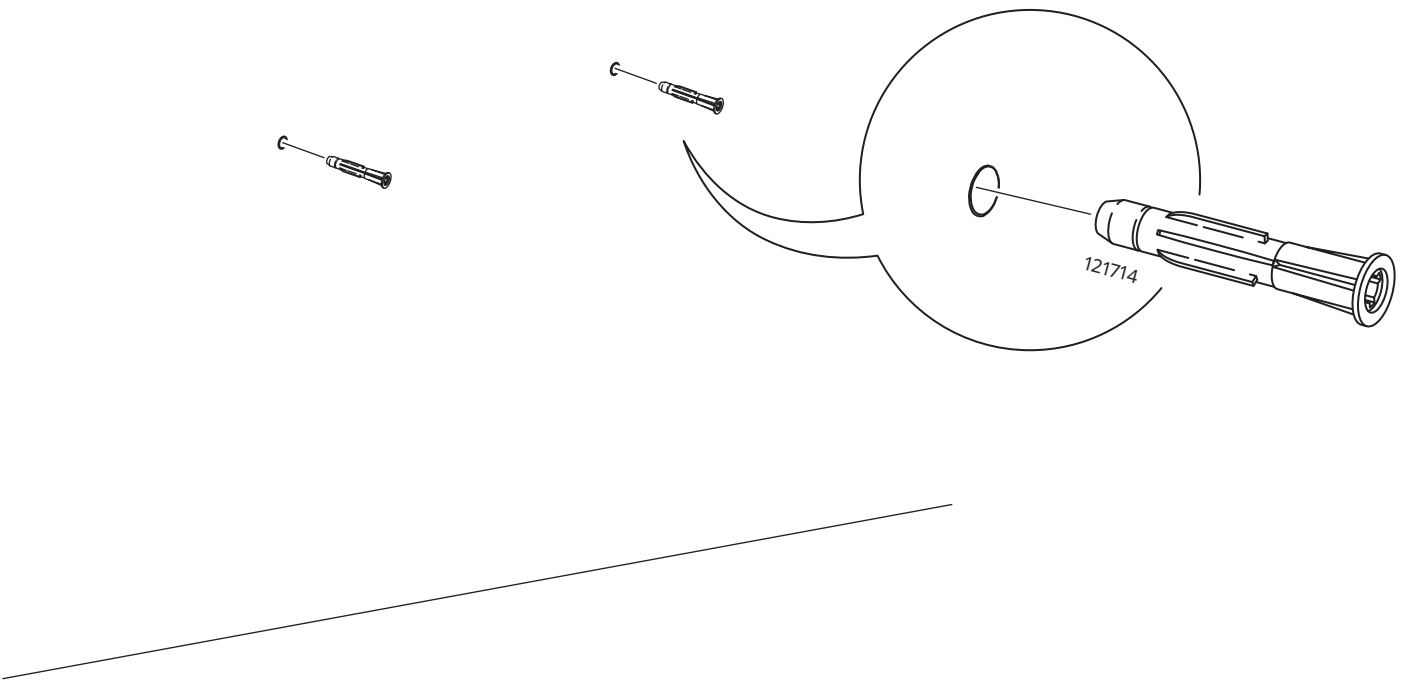

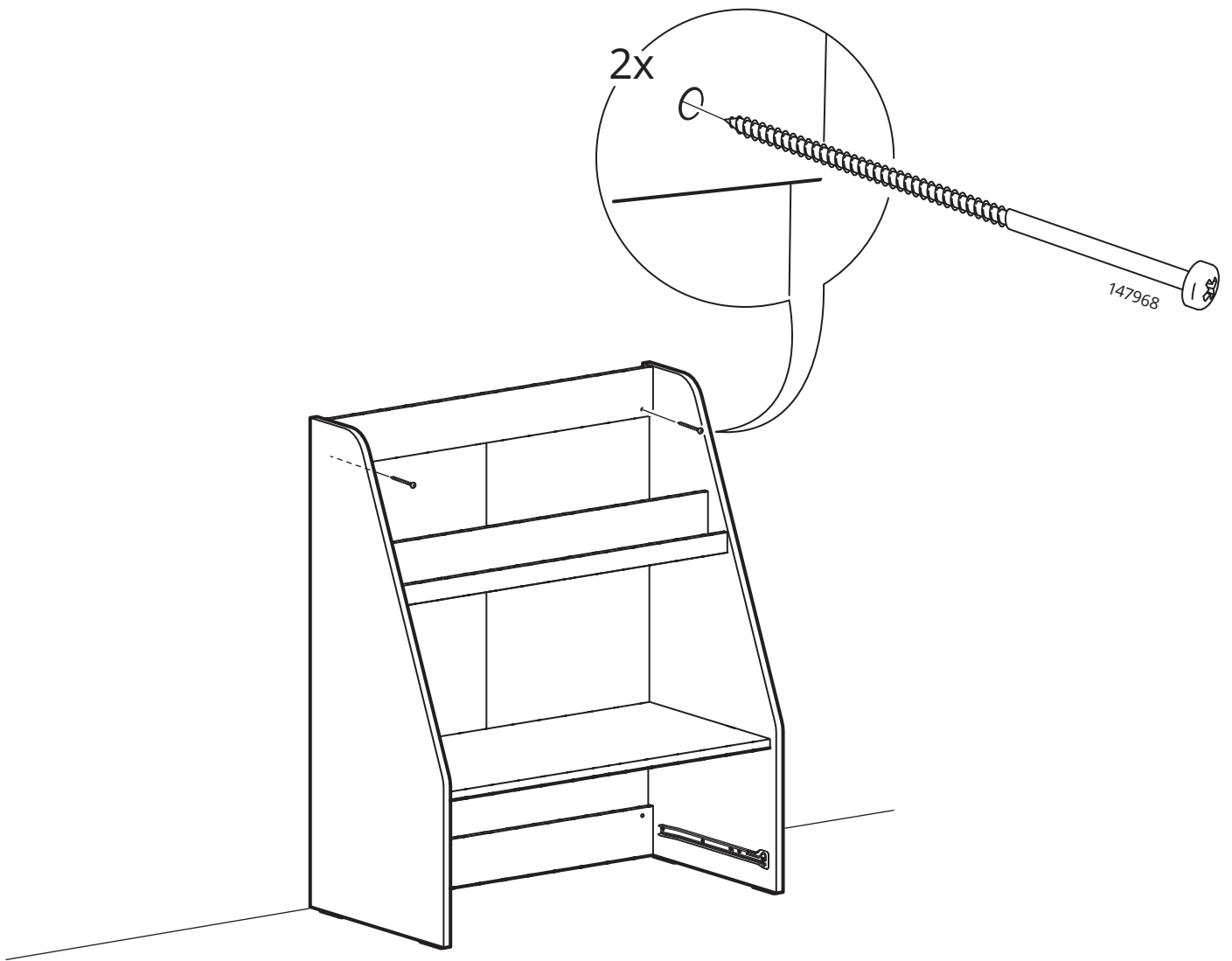

34

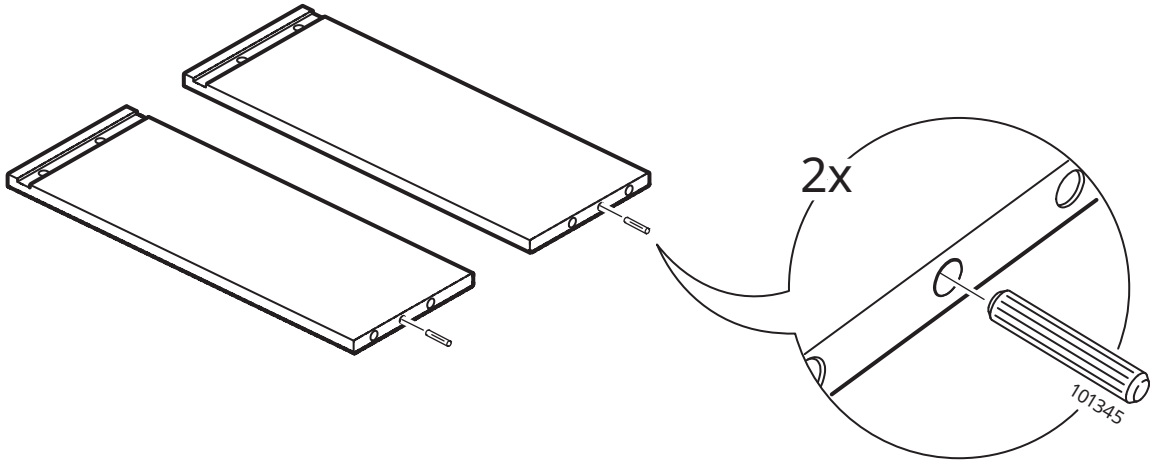

35

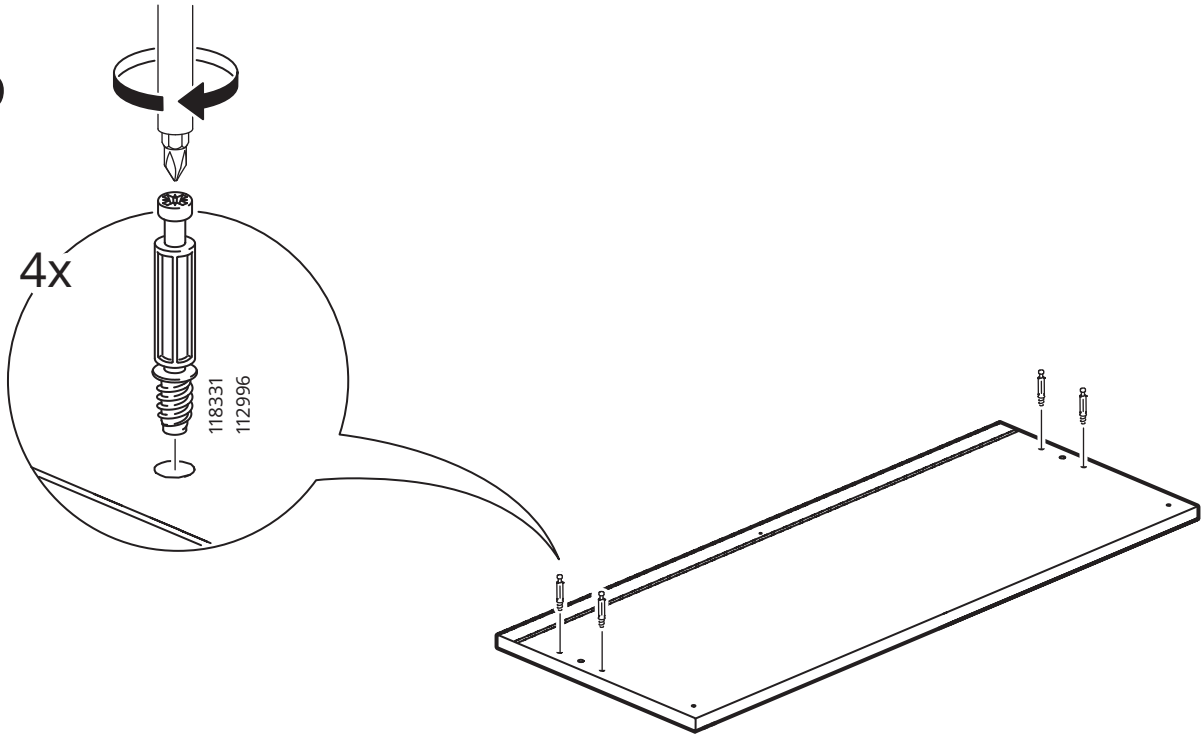

36

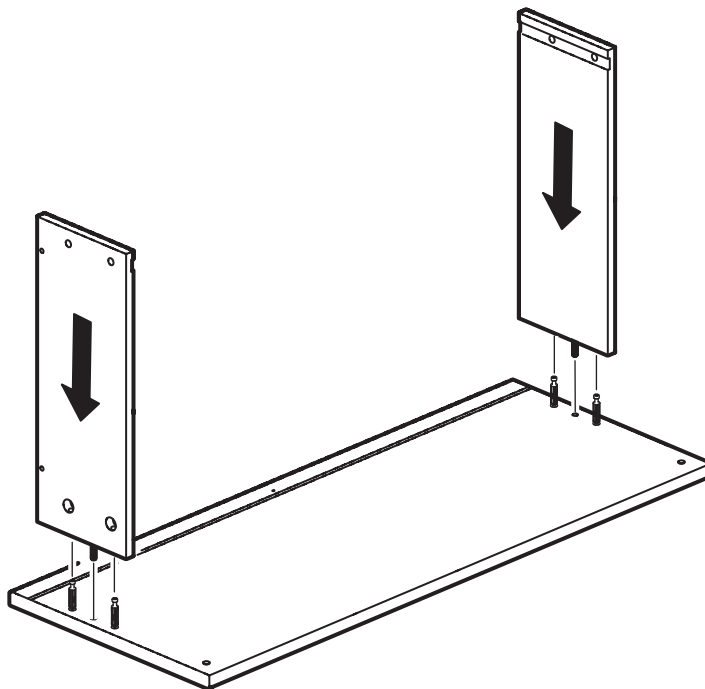

37

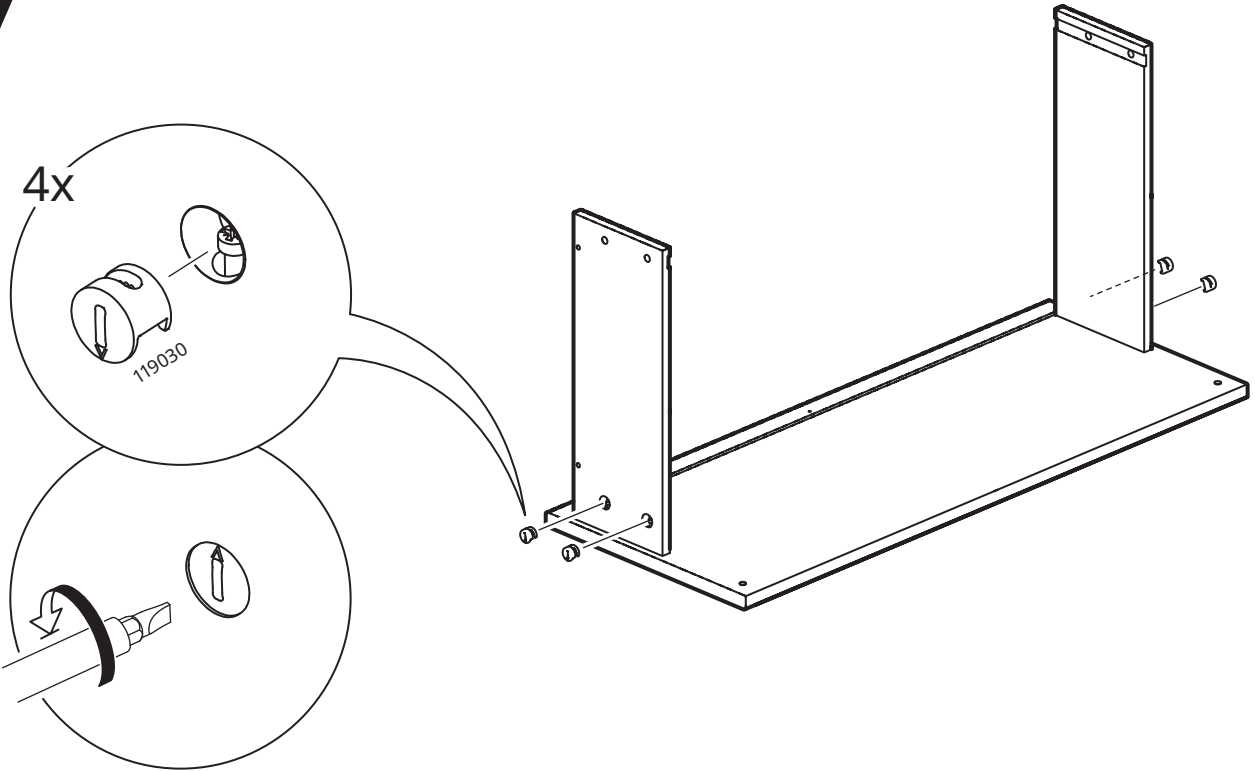

38

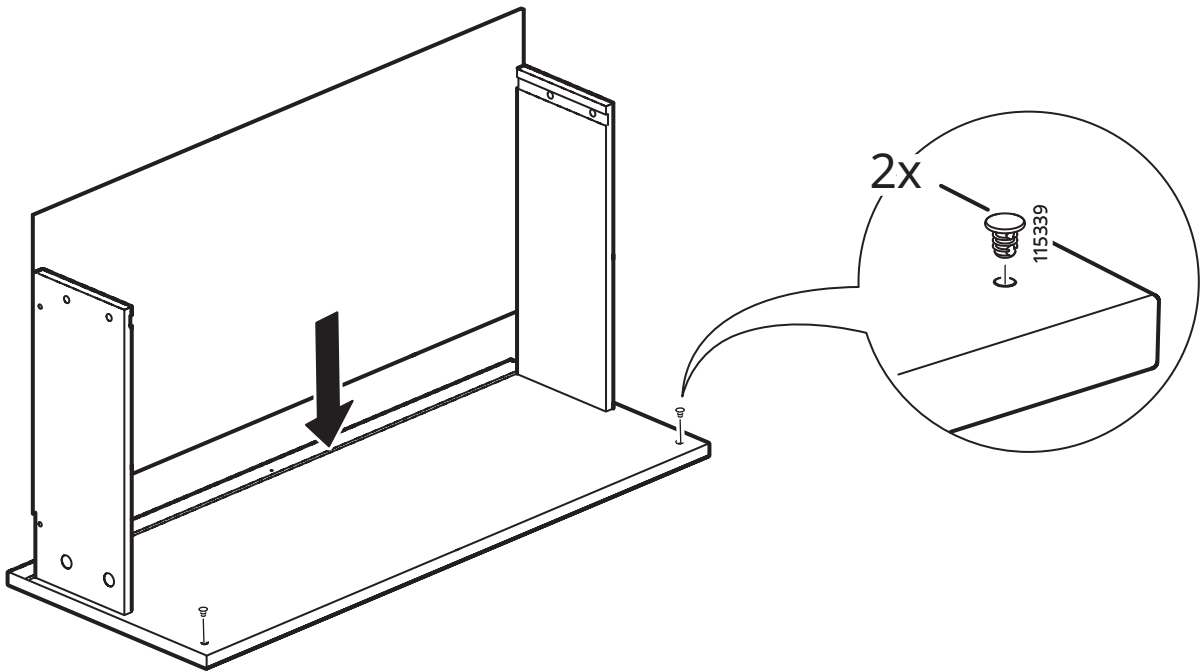

39

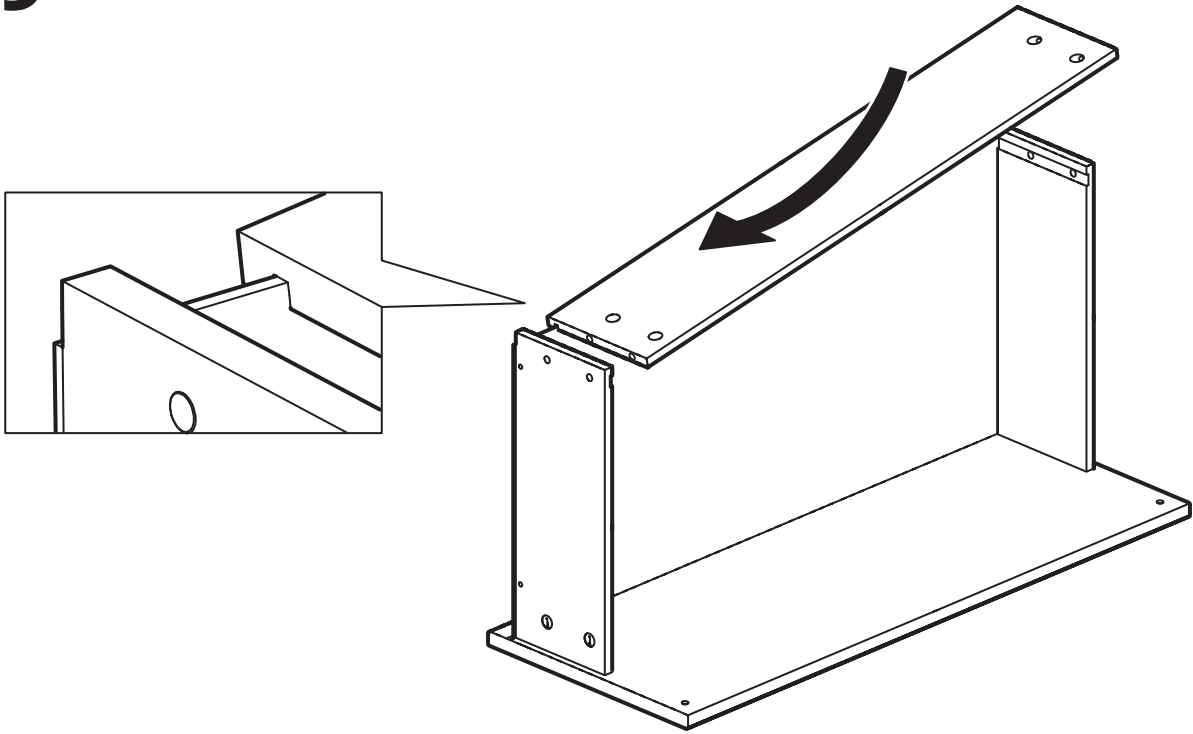

40

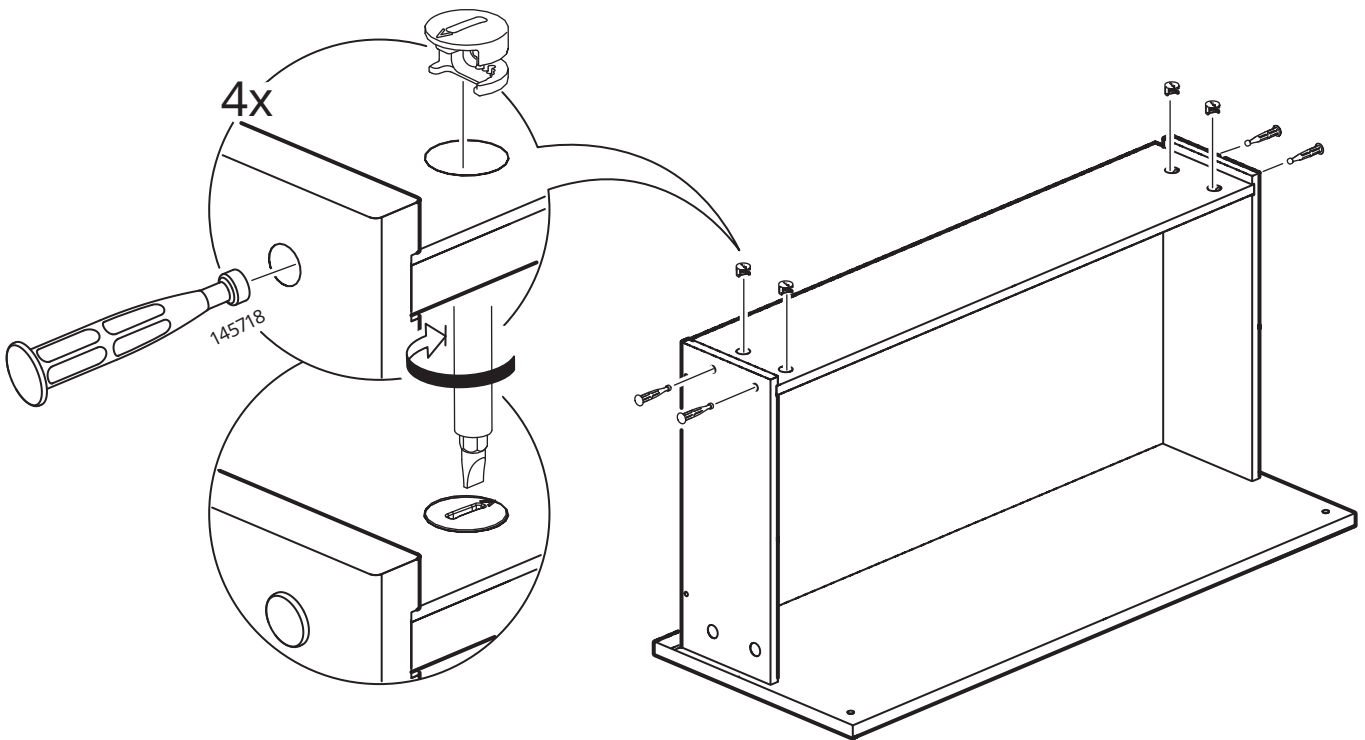

41

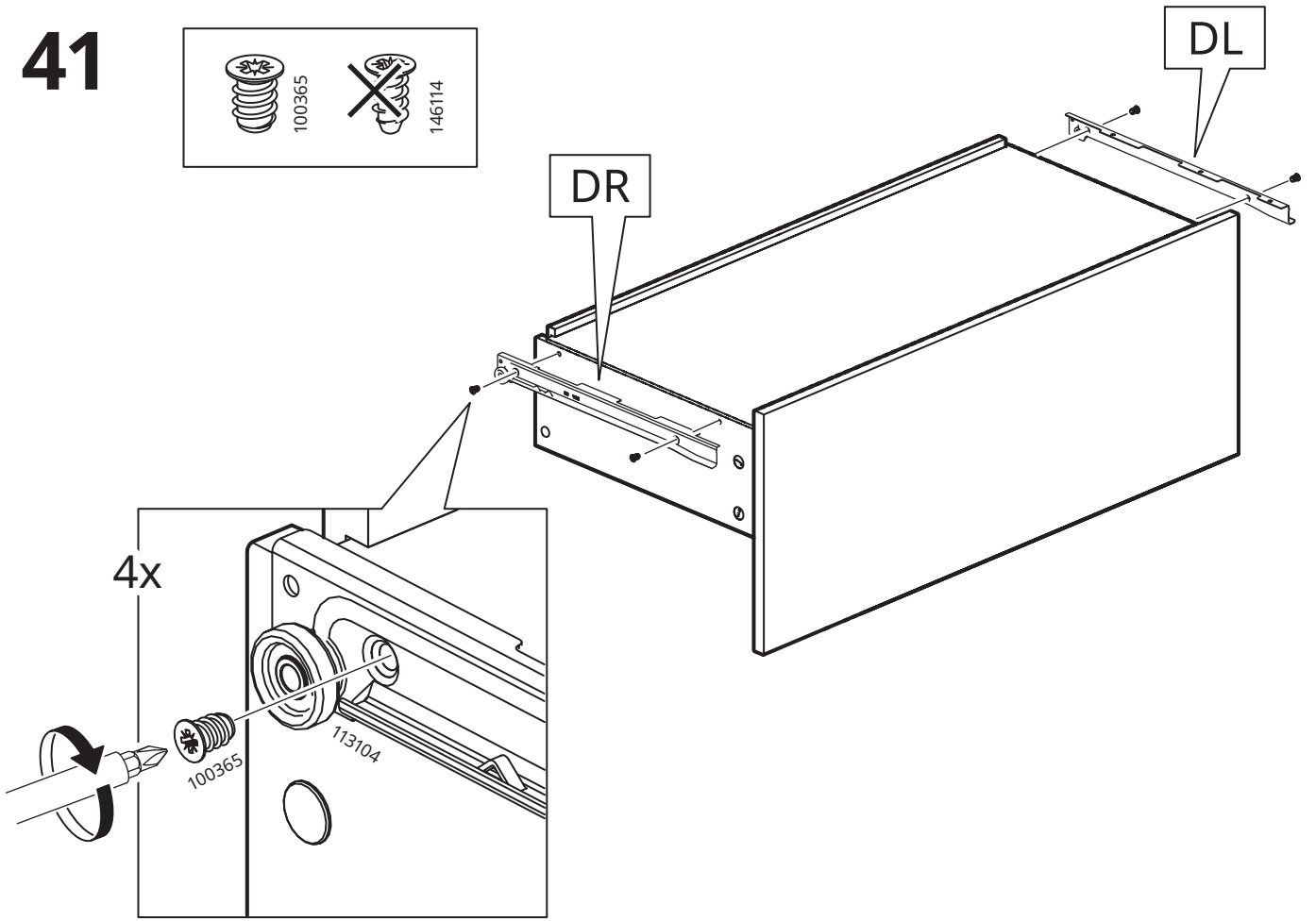
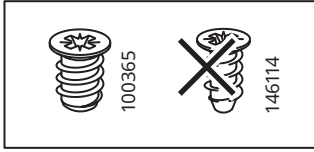

42

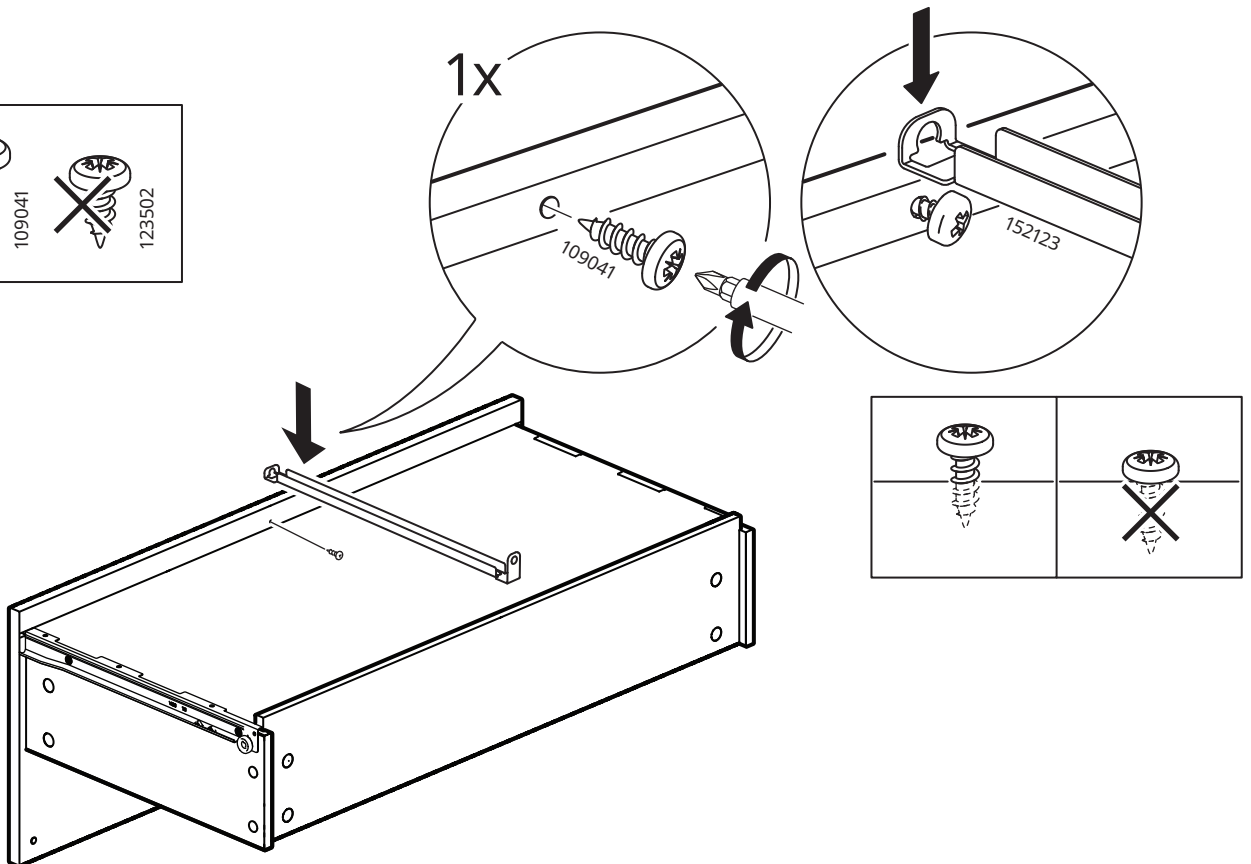
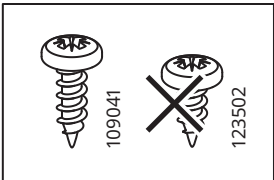

43

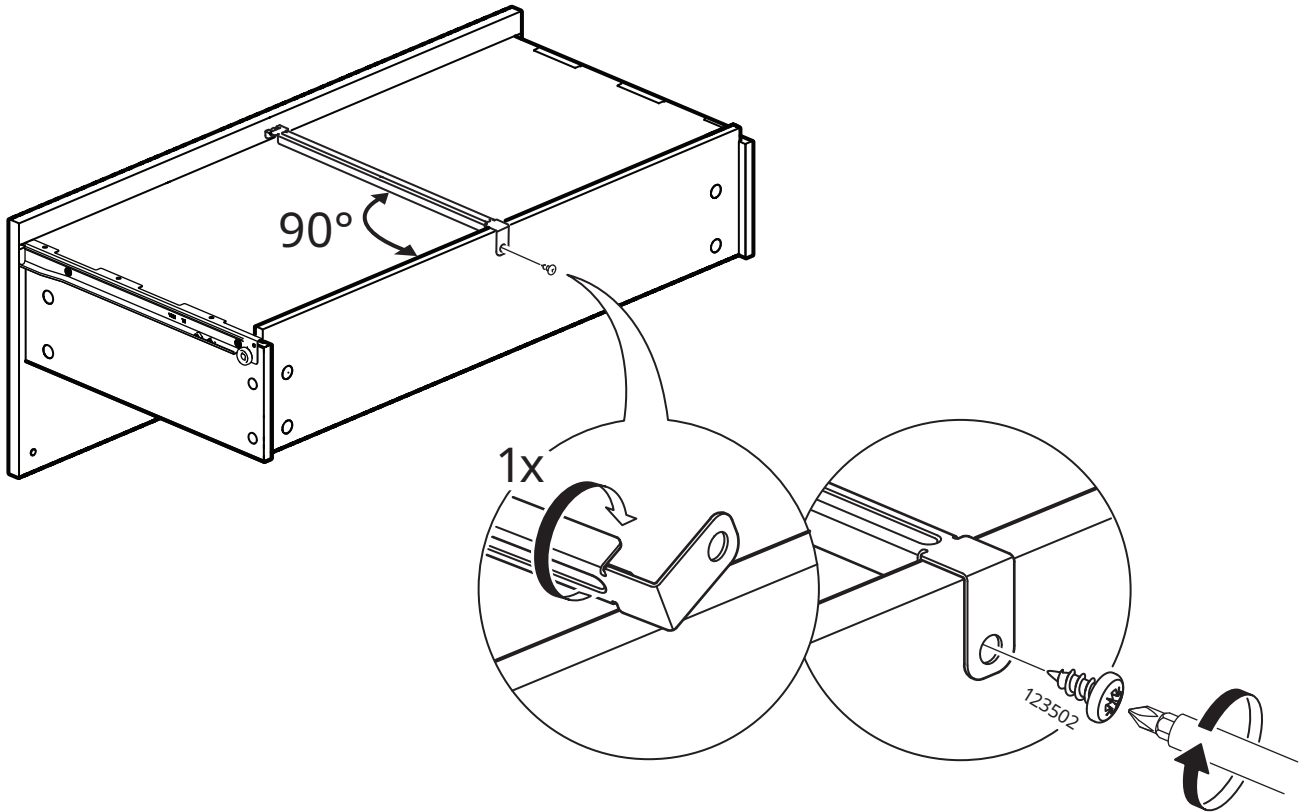
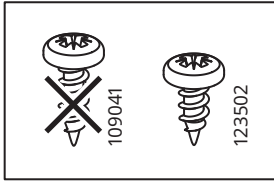

44

