

ANKARUDDEN

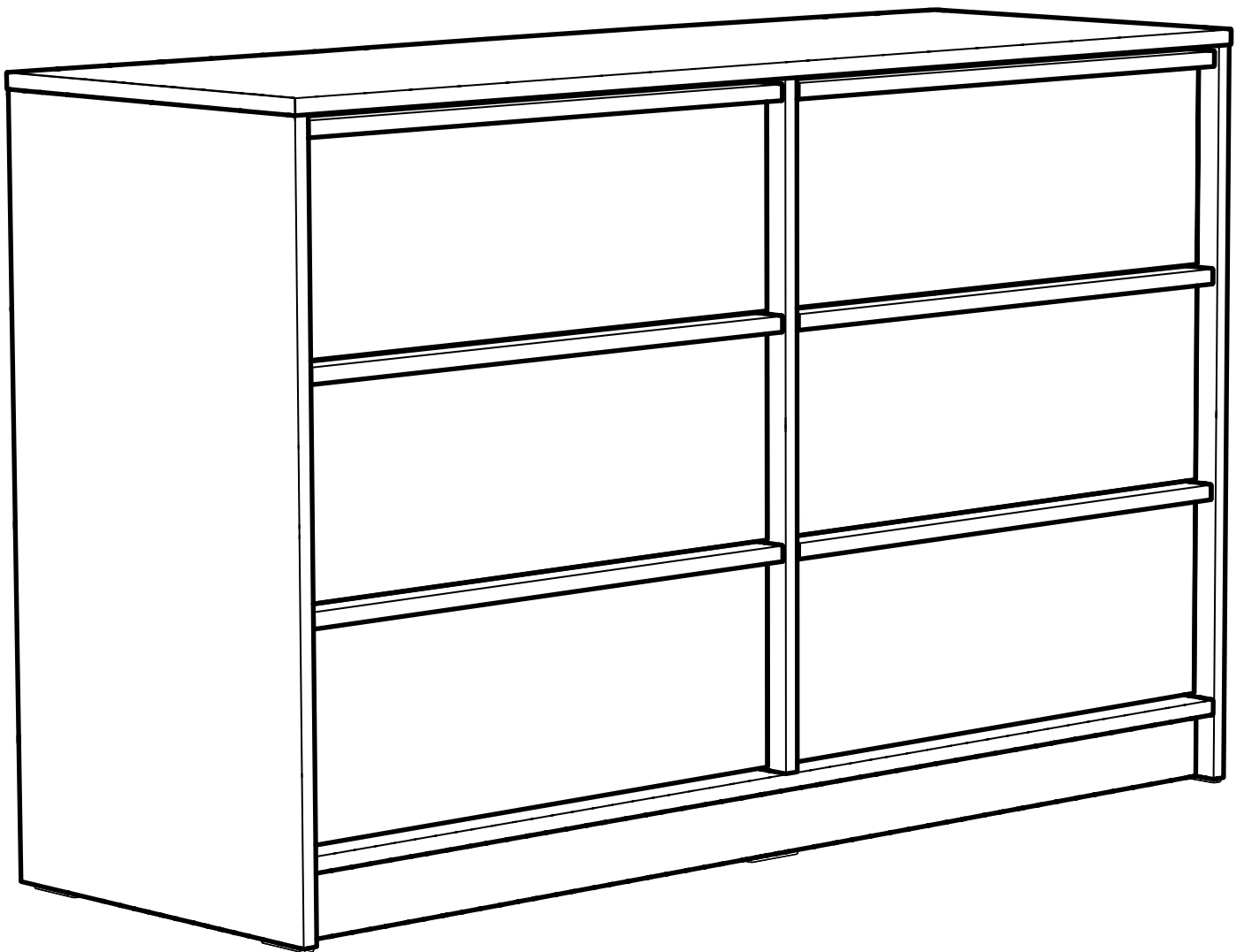

Design and Quality
IKEA of Sweden

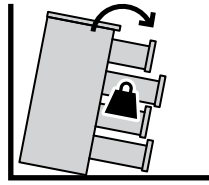
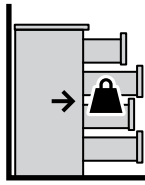
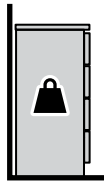

English

WARNING

Serious or fatal crushing injuries can occur from furniture tip-over.

ALWAYS secure this furniture to the wall using tip-over restraints.

To further reduce the risk of serious injury and death from tip-overs:

- Place heaviest items in the lower drawer.
- Do not set TVs or other heavy objects on top of this product.
- Never let children climb or hang on drawers, doors, or shelves.

Deutsch

ACHTUNG

Umfallende Möbelstücke können lebensgefährlich sein.

Um diesem Risiko zu entgehen, muss das Möbel **UNBEDINGT** mit dem beige packten Kippschutz an der Wand befestigt werden.

Um das Risiko schwerer oder gar tödlicher Verletzungen durch umkippende Möbelstück weiter zu mindern, bitte Folgendes beachten:

- schwere Gegenstände immer in Bodennähe aufbewahren.
- Fernsehgeräte oder andere schwere Geräte niemals auf das Produkt stellen.
- Kindern niemals erlauben, auf Schubladen, Türen und Regale zu klettern oder sich daran zu hängen.

Français

ATTENTION

Risque de blessures graves ou mortelles en cas de basculement du meuble.

TOUJOURS fixer ce meuble au mur à l'aide des fixations antibasculement.

Pour encore réduire les risques de blessures graves ou mortelles dus au basculement du meuble :

- Placer les objets les plus lourds dans le tiroir du bas.
- Ne jamais laisser les enfants grimper ou s'accrocher aux tiroirs, portes ou tablettes.

Nederlands

WAARSCHUWING

Opbergmeubels die omvallen kunnen ernstig of levensbedreigend letsel veroorzaken.

Om dat te voorkomen dient het

meubel **ALTIJD** met het meegeleverde kantelbeslag aan de muur te worden bevestigd.

Om het risico op kantelende voorwerpen en daarmee ernstig letsel of dodelijke ongevallen nog verder te vermijden, is het verstandig hiermee rekening te houden:

- Plaats zware voorwerpen altijd helemaal onderin.
- Zet nooit een tv of andere zware voorwerpen op het meubel.
- Sta niet toe dat kinderen op lades, deuren of planken klimmen of eraan gaan hangen.

Dansk

ADVARSEL!

Der kan opstå alvorlig eller livsfarlig tilskadekomst, hvis møblet vælter.

Møblet skal **ALTIJD** fastgøres til væggen med væltesikringer.

For yderligere at reducere risikoen for alvorlig tilskadekomst og dødsfald som følge af vælteulykker:

- Placer de tungeste ting i den nederste skuffe.
- Placer ikke et tv eller andre tunge genstande oven på dette produkt.
- Sørg for, at børn ikke klatrer eller hænger i skuffer, låger eller hylder.

Íslenska

VARÚÐ

Alvarleg slys eða dauðsföll geta orðið ef húsgagn fellur fram fyrir sig.

Festu þetta húsgagn **ALLTAF** við vegg með veggfestingum.

Til að draga úr hættu á alvarlegum meiðslum og dauðsfalli í kjölfar veltu:

- Settu þyngru hlutina í neðri skúffurnar.
- Aldrei leyfa börnum að klifra eða hanga á skúffum, hurðum eða hillum.

Norsk

ADVARSEL

Oppbevaringsmøbler som velter kan forårsake alvorlige eller livstruende skader.

For å unngå dette skal du **ALLTID** feste møblene i veggene med de inkluderte beslagene.

For å redusere faren ytterligere for at veltende gjenstander forårsaker alvorlige eller dødelige skader:

- Plasser alltid tunge gjenstander nederst.
- Plasser aldri TV-apparater eller andre tunge gjenstander opp på møbelet.
- La aldri barn klatre eller henge på skuffer, dører eller hyller.

Suomi

VAROITUS

Huonekalun kaatuminen voi aiheuttaa vakavia ja jopa kuolemaan johtavia vammoja.

Huonekalu on **AINA** kiinnitettävä seinään pakkauksessa olevalla seinäkiinnikkeellä.

Kaatumisen estämiseksi tulee noudattaa myös seuraavia ohjeita:

- Sijoita painavimmat tavarat alalaatikkoon.
- Älä sijoita tv:tä tai muita painavia tavaroita tämän huonekalun päälle.
- Älä anna lasten roikkua tai kiipeillä laatikoissa, ovissa tai hyllyillä.

Svenska

VARNING

Förvaringsmöbler som välter kan orsaka allvarliga eller livshotande skador.

För att undvika detta ska du **ALLTID** fästa möbelen i väggen med de tippskyddsbeslag som medföljer.

För att ytterligare minimera risken för att våltande föremål orsakar allvarliga eller dödliga skador bör du tänka på följande:

- Placera alltid tunga föremål längst ner.
- Placera aldrig TV-apparater eller andra tunga föremål ovanpå möbelen.
- Tillåt aldrig barn att klättra eller hänga på lådor, dörrar eller hyllor.

Česky

UPOZORNĚNÍ

Převržení nábytku může mít vážné nebo fatální následky.

VŽDY připevněte tento nábytek ke stěně pomocí přiloženého kování.

Abyste ještě více snížili nebezpečí vážného zranění nebo smrti z převržení nábytku:

- Nejtěžší věci dávejte do nejnižší zásuvky.
- Nedávejte na tento výrobek televizi nebo jiné těžké předměty.
- Nikdy nenechávejte děti šplhat nebo se věšet na zásuvky, dvířka a police.

Español

ADVERTENCIA

Si el mueble vuelca, puede provocar lesiones muy graves e incluso mortales.

Fija SIEMPRE este mueble a la pared utilizando los accesorios antivuelco.

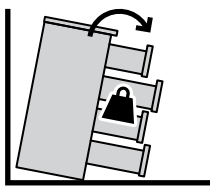
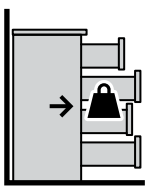
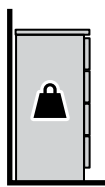

Para reducir aún más el riesgo de lesiones graves o incluso mortales causadas por el vuelco del mueble:

- Guarda los objetos más pesados en el cajón inferior.
- No pongas un TV u otros objetos pesados encima de este producto.
- Evita que los niños suban encima del mueble o se cuelguen de los cajones, las puertas o los estantes.

Italiano

AVVERTENZA

Se il mobile si ribalta può causare lesioni da schiacciamento gravi o mortali.

Fissa SEMPRE questo mobile alla parete usando i componenti di sicurezza.

Per ridurre ulteriormente il rischio di lesioni gravi o mortali causate dal ribaltamento:

- Metti gli oggetti più pesanti nel cassetto inferiore.
- Non collocare la TV o altri oggetti pesanti sopra questo prodotto.
- Evita che i bambini si appendano o si arrampichino sui cassetti, sulle ante o sui ripiani.

Magyar

FIGYELEM!

A bútor felborulása súlyos, akár életveszélyes sérüléseket okozhat.

MINDIG rögzítsd biztonságosan a falhoz a bútort, ehhez használd felborulás gátló kellékeket.

A felborulás miatti sérülések kockázata tovább csökkenthető:

- A legnehezebb tárgyakat az alsó fiókokba tedd.
- Ne helyezz TV-t, vagy egyéb nehéz tárgyat a bútor tetejére.
- Soha ne engedd, hogy a gyerekek a fiókokon, ajtókon, polcokon felmásszanak, rajtuk függeszkedjenek.

Polski

OSTRZEŻENIE

Przewrócenie się mebli może spowodować poważne lub śmiertelne obrażenia ciała na skutek przycięcia.

ZAWSZE przymocuj ten mebel do ściany za pomocą ograniczników przechyłu.

Aby dodatkowo zminimalizować ryzyko poważnych obrażeń ciała i śmierci na skutek przewrócenia się mebla:

- Umieść najcięższe przedmioty w dolnej szufladzie.

- Nie stawiaj na meblu telewizora, ani innych ciężkich przedmiotów.

- Nigdy nie pozwalaj dzieciom wspinać się na szuflady, drzwiczki lub półki.

Eesti

HOIATUS

Mööbli kukkumisele võivad järgneda tõsised või surmaga lõppevad juhtumid.

ALATI kinnitage see mööbliese seinale külge, kasutades vastavaid kinnitusi.

Et vigastus- või surmaohtu veelgi vähendada:

- Pange raskeimad esemed alumistesse sahtlitesse.
- Ärge pange tootele televiisoreid või muid raskeid esemeid.
- Ärge kunagi laske lastel ronida või rippuda sahtlitel, ustel või riulitel.

Latviešu

UZMANĪBU

Mēbelēm apgāzoties, iespējams gūt nopietnas vai nāvējošas traumas.

VIENMĒR nostipriniet mēbeles pie sienas, izmantojot stiprinājumus.

Lai maksimāli izvairītos no nopietnu vai nāvējošo traumu riska, mēbelēm apgāzoties:

- Novietojiet smagākos priekšmetus apakšējās atvilktnēs.
- Virs precēs nenovietojiet televizorus vai citus smagus objektus. - Nekādā gadījumā neļaujiet bērniem rāpties vai karāties uz atvilktnēm, durvīm un plauktiem.

Lietuvių

SVARBU

Užvirtus baldams galima patirti sunkių arba mirtinų traumų.

VISADA pritvirtinkite baldus prie sienos tam skirtais laikikliais.

Kad dar labiau sumažintumėte sunkių sužalojimų ir mirties riziką dėl užvirtimo:

- Sunkiausias daiktus laikykite apatiniaame stalčiuje.
- Ant šio ir panašių baldų nelaikykite sunkių daiktų, pavyzdžiui, televizoriaus.
- Neleiskite vaikams karštytis ant stalčių, durelių ar lentynų, ant jų kabėti.

Portugues

IMPORTANTE

A queda de móveis pode provocar ferimentos graves ou fatais.

Fixe SEMPRE este móvel à parede com acessórios de fixação.

Para reduzir o risco de ferimentos graves ou morte pela queda de móveis:

- Coloque os itens mais pesados nas gavetas mais baixas.
- Não coloque televisões ou outros objetos pesados em cima deste artigo.
- Nunca permita que as crianças subam ou se pendurem nas gavetas, portas e prateleiras.

Româna

AVERTISMENT!

Răsturnarea mobilierului poate provoca răniri grave sau fatale.

Fixează ÎNTOTDEAUNA mobilierul de perete folosind dispozitive anti-răsturnare.

Pentru a reduce riscul de rănire gravă sau deces din cauza răsturnării mobilierului:

- Așază obiectele mai grele în sertarul de jos.
- Nu așeza televizorul sau alte obiecte mai grele deasupra acestui produs.
- Nu lăsa copiii să se urce sau să se agațe de sertare, uși sau polițe.

Slovensky

UPOZORNENIE

Prevrátenie nábytku môže mať za následok vážne alebo smrteľné zranenie.

VŽDY upevnite tento nábytok ku stene pomocou zábran proti prevráteniu.

Ak chcete znížiť nebezpečenstvo vážnych zranení a úmrtí spôsobených prevrátením:

- Umiestňujte najťažšie predmety do spodnej zásuvky.
- Neumiestňujte na výrobnok televízor alebo iné ťažké predmety.
- Nikdy nedovoľte deťom liezť a vešať sa na zásuvky, dvierka alebo poličky.

Български

ВНИМАНИЕ

Сериозни или фатални инциденти могат да възникнат при прекатурването на мебели.

ВИНАГИ прикрепяйте тези мебели към стената, като използвате скоби.

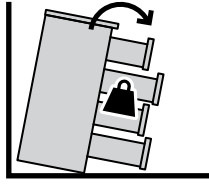
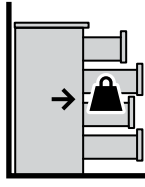
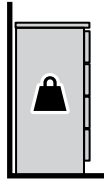

За да намалите риска от сериозни наранявания и смърт при прекатурване на мебели:

- Поставете най-тежките предмети в най-долното чекмедже.
- Не поставяйте телевизор или други тежки предмети върху този продукт.
- Не позволявайте на децата да се катерят или да се увесват на чекмеджетата, вратичките или рафтовете.

Hrvatski

UPOZORENJE

Namještaj koji se prevrne može uzrokovati ozbiljne ili smrtonosne ozljede.

UVIJEK pričvrstite namještaj na zid s pomoću priloženih pričvrstnika.

Za smanjenje rizika od ozbiljnih ili smrtonosnih ozljeda:

- Postaviti najteže predmete u najnižu ladicu.
- Ne postavljati TV ili druge teške predmete na ovaj proizvod.
- Ne dozvoliti djeci da se penju na ladice, vrata ili police ili vješaju o njih.

Ελληνικά

ΠΡΟΕΙΔΟΠΟΙΗΣΗ

Μπορεί να проκληθούν σοβαροί ή θανάσιμοι τραυματισμοί από τυχόν ανατροπή του επίπλου.

ΠΑΝΤΑ να ασφαλίσετε αυτό το έπιπλο στον τοίχο χρησιμοποιώντας τα εξαρτήματα στερέωσης.

Για να ελαχιστοποιήσετε τον κίνδυνο τραυματισμού από ανατροπή:

- Τοποθετήστε τα πιο βαριά αντικείμενα στο πιο χαμηλό συρτάρι.
- Μην τοποθετείτε τηλεοράσεις ή άλλα βαριά αντικείμενα στο πάνω μέρος αυτού του προϊόντος.
- Ποτέ μην αφήνετε τα παιδιά να σκαρφαλώσουν ή να κρεμαστούν στα συρτάρια, στις πόρτες ή στα ράφια.

Українська

ПОПЕРЕДЖЕННЯ

Перекидання меблів може спричинити серйозні травми, що можуть мати летальні наслідки.

ЗАВЖДИ перевіряйте, щоб меблі було закріплено до стіни за допомогою механізмів захисту від перекидання.

Щоб зменшити ризик серйозних травм або смерті, спричинених перекиданням:

- Розміщуйте найважчі предмети у шухлядах знизу.
- Не розміщуйте телевизор або інші важкі предмети зверху.
- Не дозволяйте дітям залазити або висіти на шухлядах, дверцятках або полицях.

Srpski

UPOZORENJE

Prevrtanje nameštaja može da izazove nastanak ozbiljnih ili fatalnih povreda.

UVEK pričvrstite ovaj nameštaj za zid pomoću fiksatora koji sprečavaju njegovo prevrtanje.

Da smanjiš opasnost od teških povreda i smrti usled prevrtanja nameštaja:

- Najteže predmete stavljaj u najnižu fioku.
- Ne stavljaj TV niti druge teške predmete na vrh ovog proizvoda.
- Nikada ne dozvoljavaj deci da se penju niti vise na fiokama, vratima ili policama.

Slovenščina

OPOZORILO

Prevrnitev pohištva lahko privede do hudih telesnih poškodb ali smrti.

VEDNO pritrdi ta kos pohištva v steno z varovali proti prevrnitvi.

Dodatni ukrepi za zmanjšanje možnosti resnih ali smrtnih poškodb zaradi prevrnitve pohištva:

- težje predmete shranjuj v spodnjem predalu;
- na ta izdelek ne nameščaj televizorja in ne odlagaj drugih težkih predmetov;
- otrokom prepričaj, da bi plezali ali se obešali na predale, vrata ali police.

Türkçe

UYARI

Ezilmelere bağlı ciddi veya ölümcül yaralanmalar, mobilya devrilmesi sonucunda meydana gelebilir.

Bu mobilya, HER ZAMAN sabitleme aparatı ile duvara sabitlenmelidir.

Devrilmelere bağlı ciddi veya ölümcül yaralanma riskini daha aza indirebilmek için:

- En ağır eşyaları alt çekmeceye yerleştiriniz.
- TV veya diğer ağır eşyaları bu ürünün üzerine yerleştirmeyiniz.
- Çocukların çekmece, kapak veya raflara asılmalarına ya da tırmanmalarına izin vermeyiniz.

عربي

تحذير!



قد تحدث إصابات بالغة أو مميتة نتيجة إنقلاب الأثاث.

يُتَبَن هذا الأثاث دائماً على الحائط بواسطة أدوات التثبيت المانعة للإنقلاب.

لتقليل مخاطر الإصابة الخطرة والتعرض للموت نتيجة إنقلاب الأثاث:

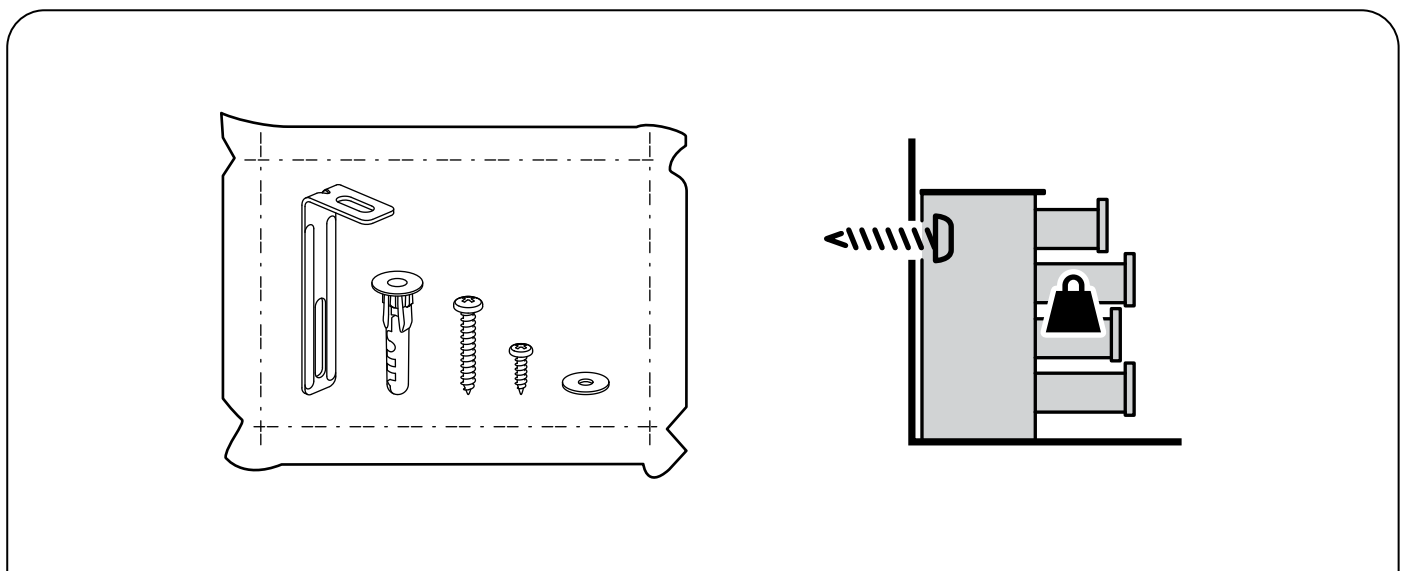
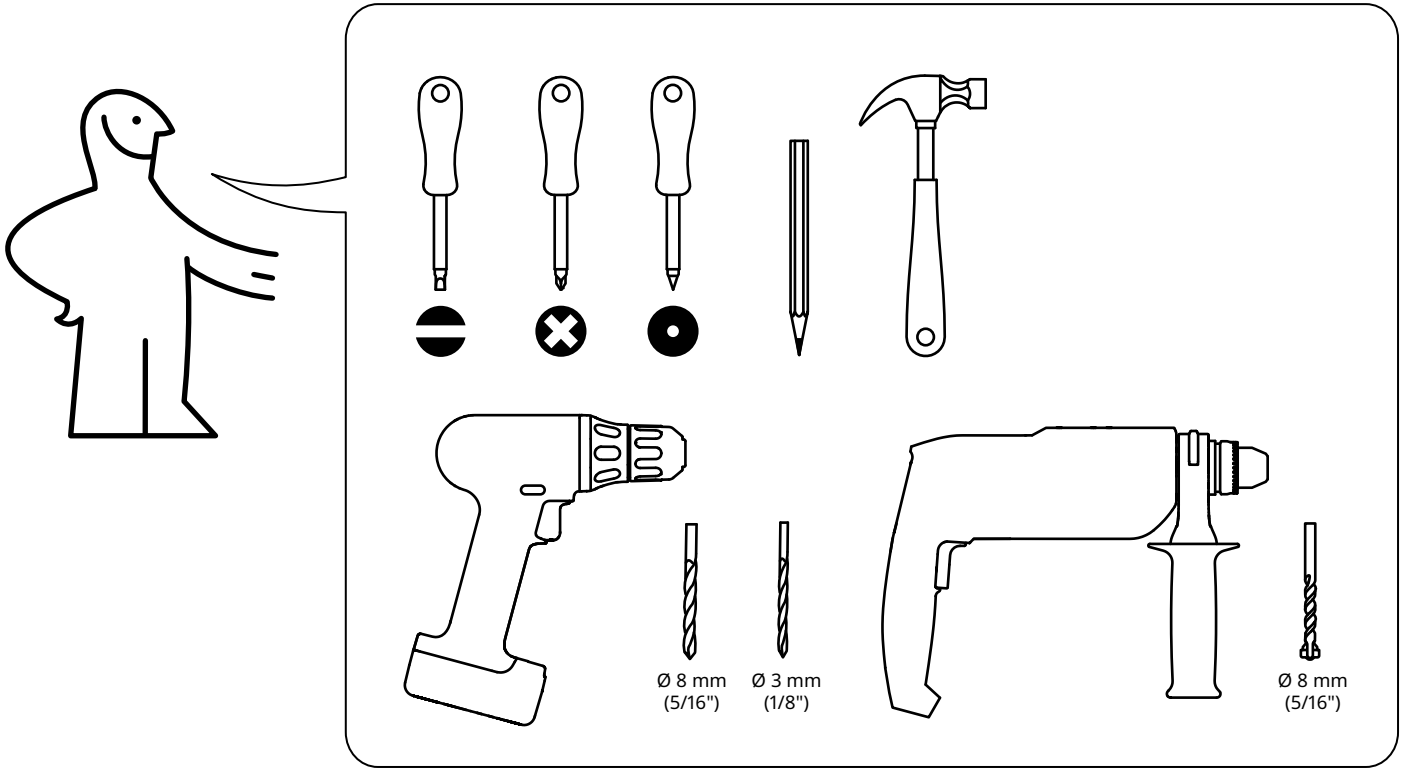
- ضع الأشياء الثقيلة في الدرج السفلي.
- لا تضع تلفزيون أو أي أشياء ثقيلة أخرى فوق هذا المنتج.
- لا تسمح أبداً للأطفال بتسلق أو التعلق على الأدراج، الأبواب، أو الأرفف.

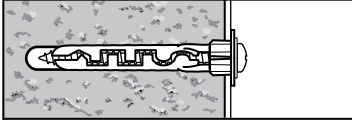
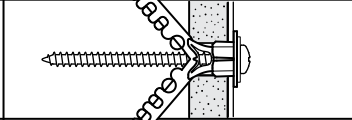
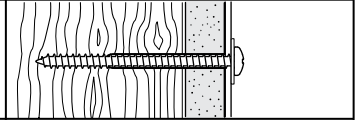
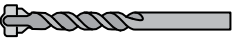

	A	B	C
			
<p>www.IKEA.com/secure-it</p>	<p>$\text{\O} 8 \text{ mm}$ ($5/16''$)</p> 	<p>$\text{\O} 8 \text{ mm}$ ($5/16''$)</p> 	<p>$\text{\O} 3 \text{ mm}$ ($1/8''$)</p> 

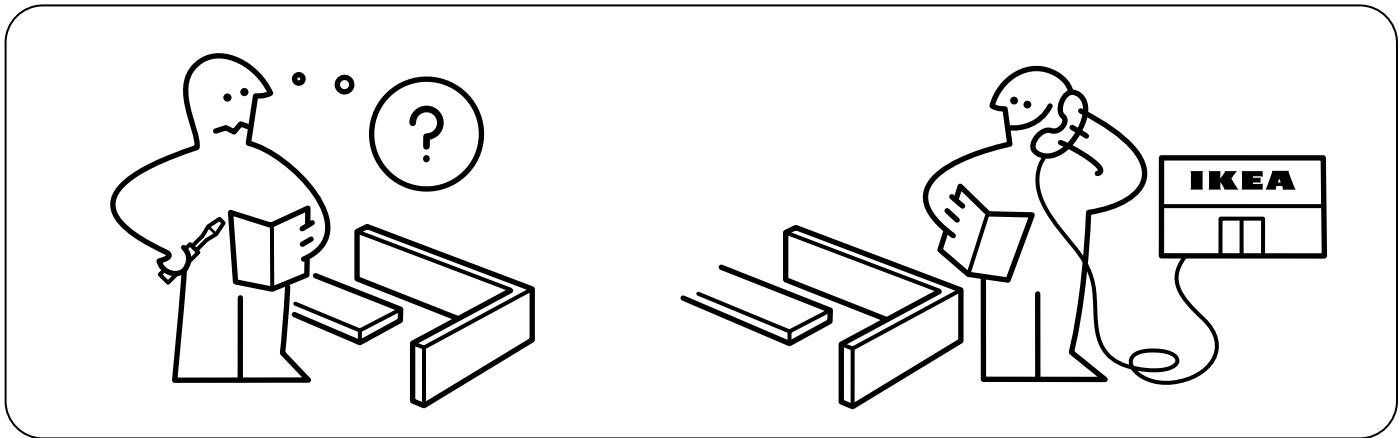
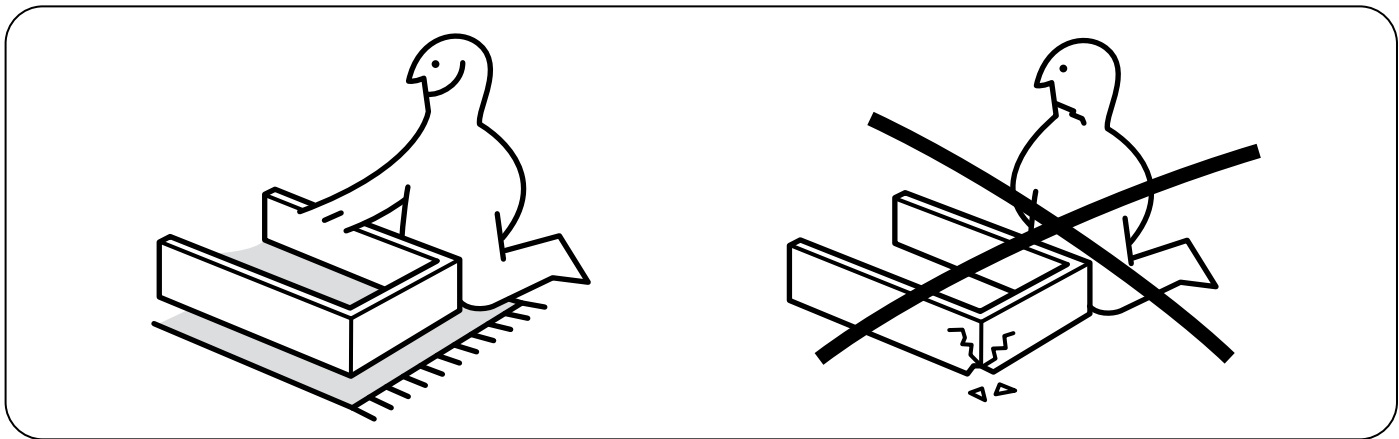
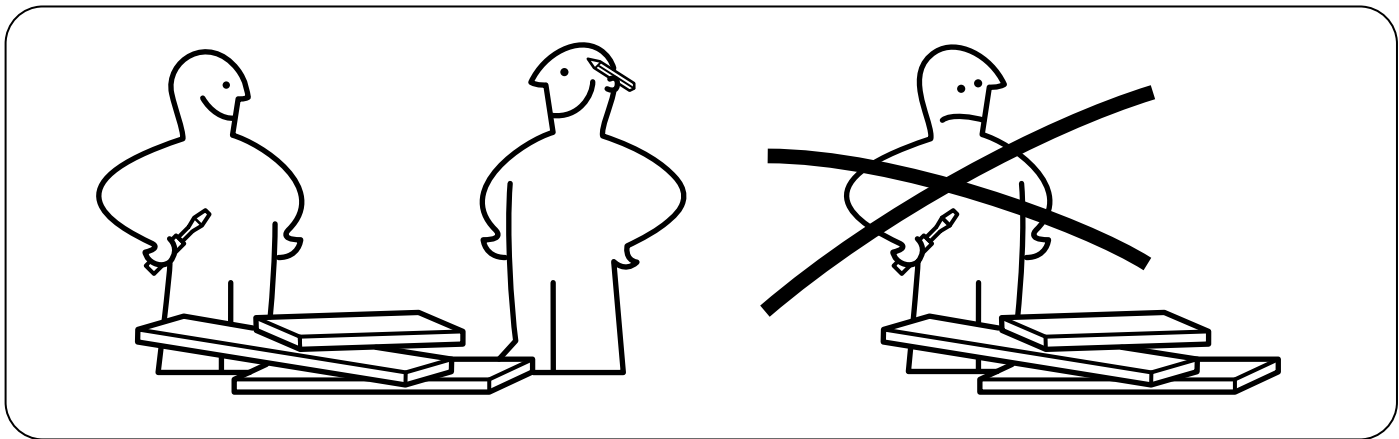

1

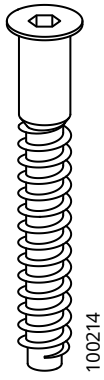

2x

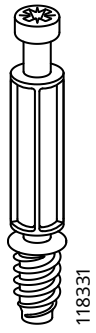

22x



8x



36x

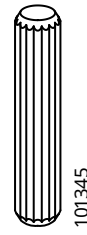

40x



22x

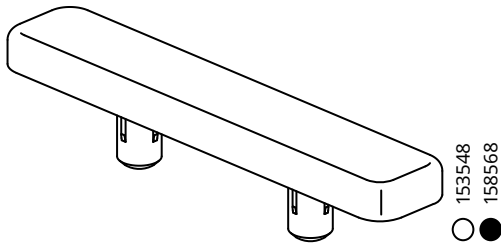

6x

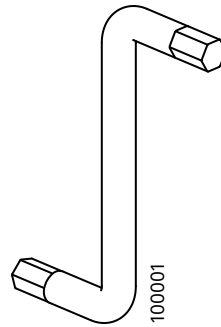

1x

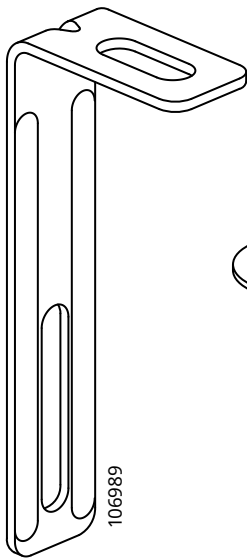

2x

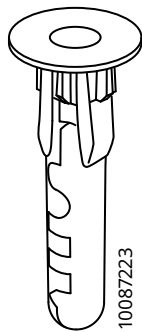

2x

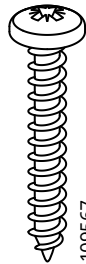

2x



2x

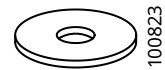

4x

2



102323

4x



115339

4x

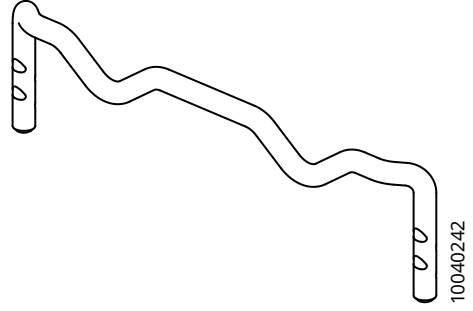

10040242

8x

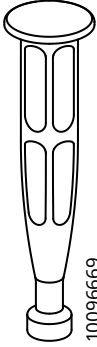

10096669

32x

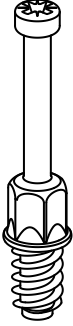

130449

28x

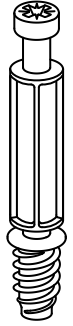

118331

18x



146114

36x



101345

16x



10097796

18x

119250



120076

60x

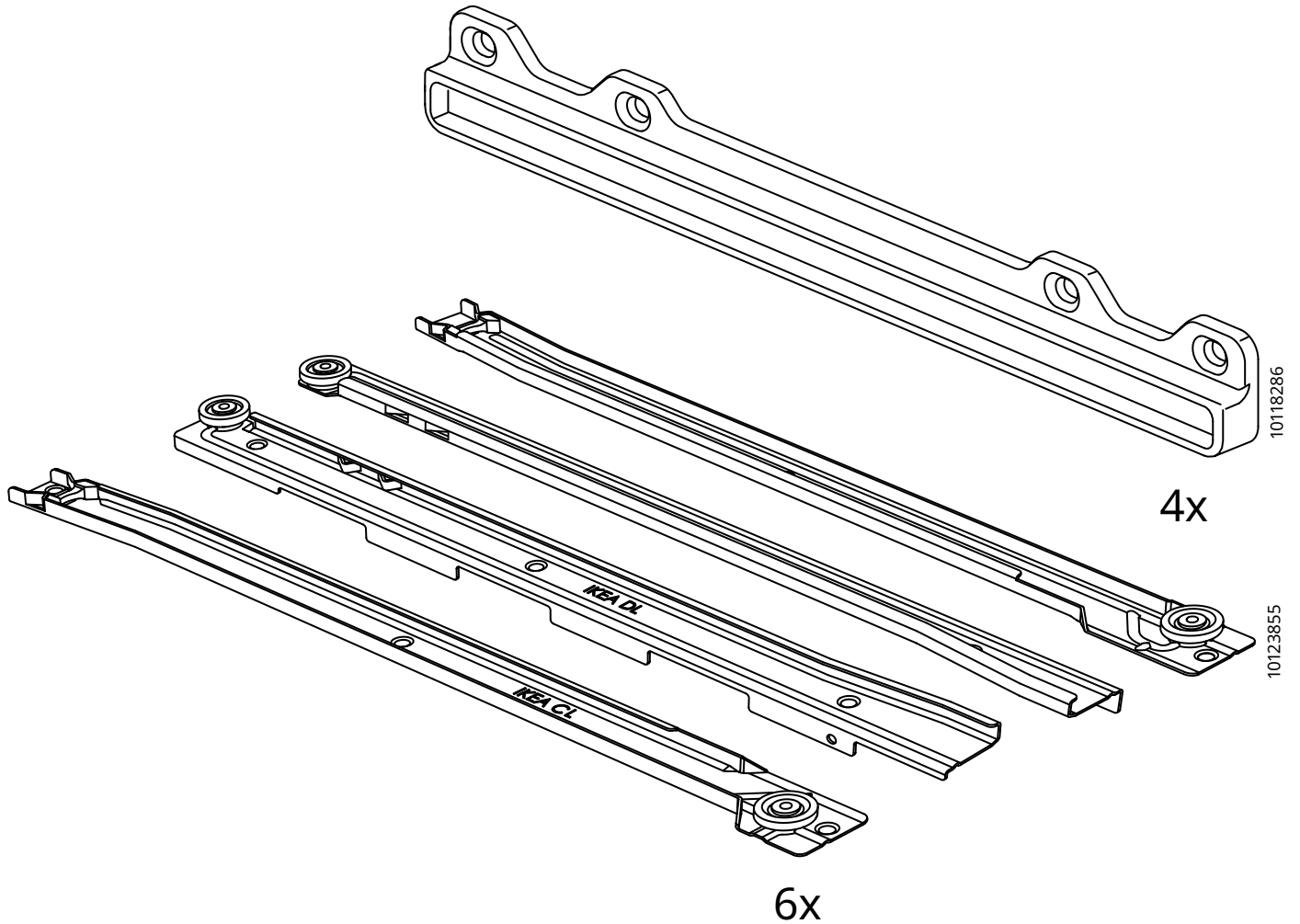

1

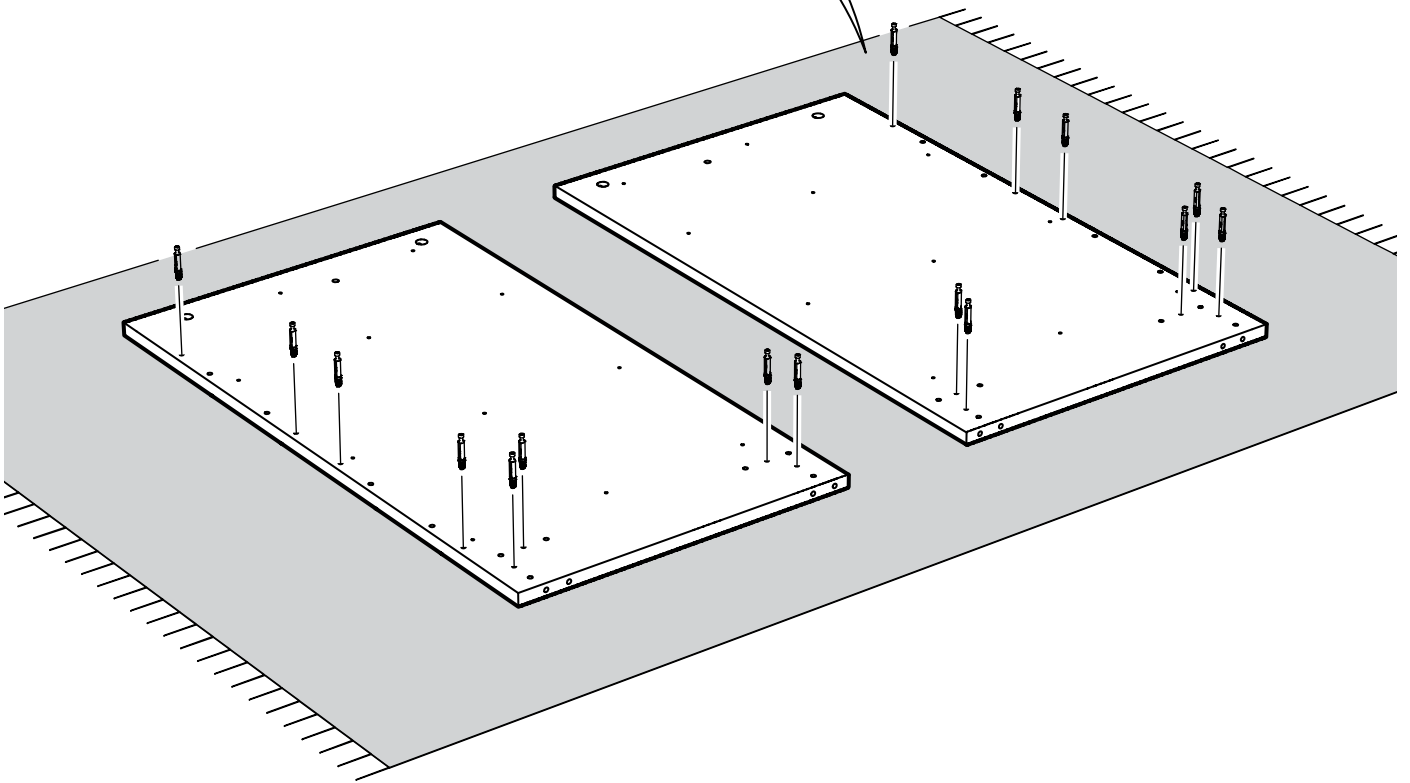
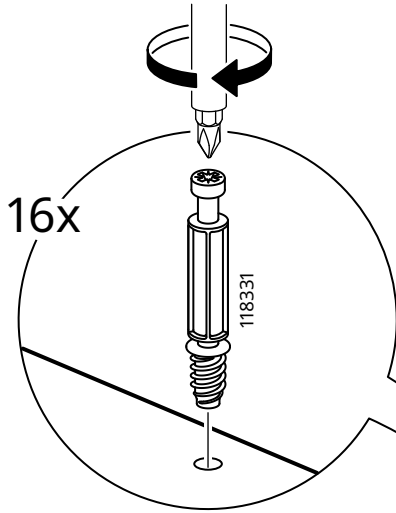

2

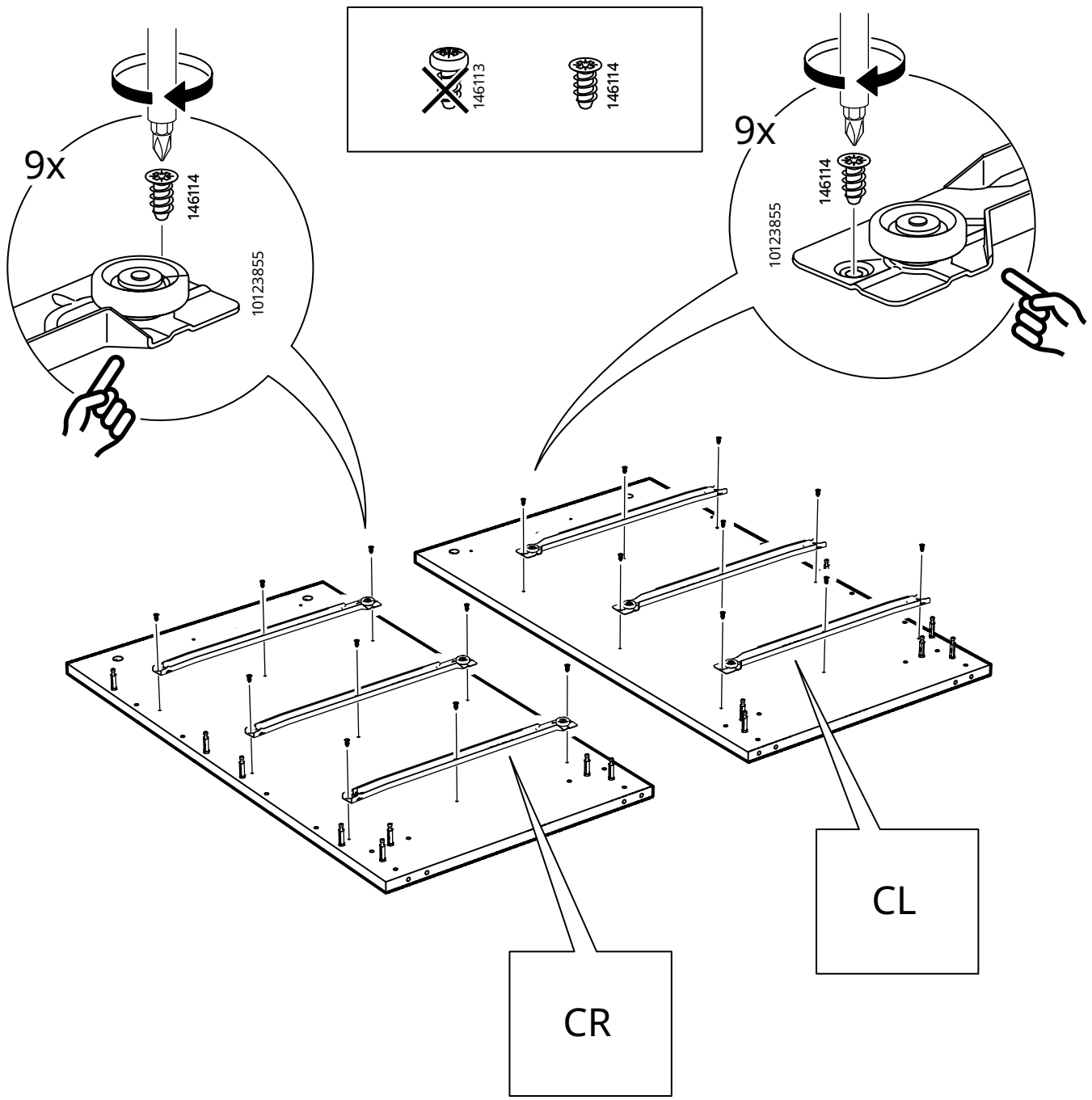

3

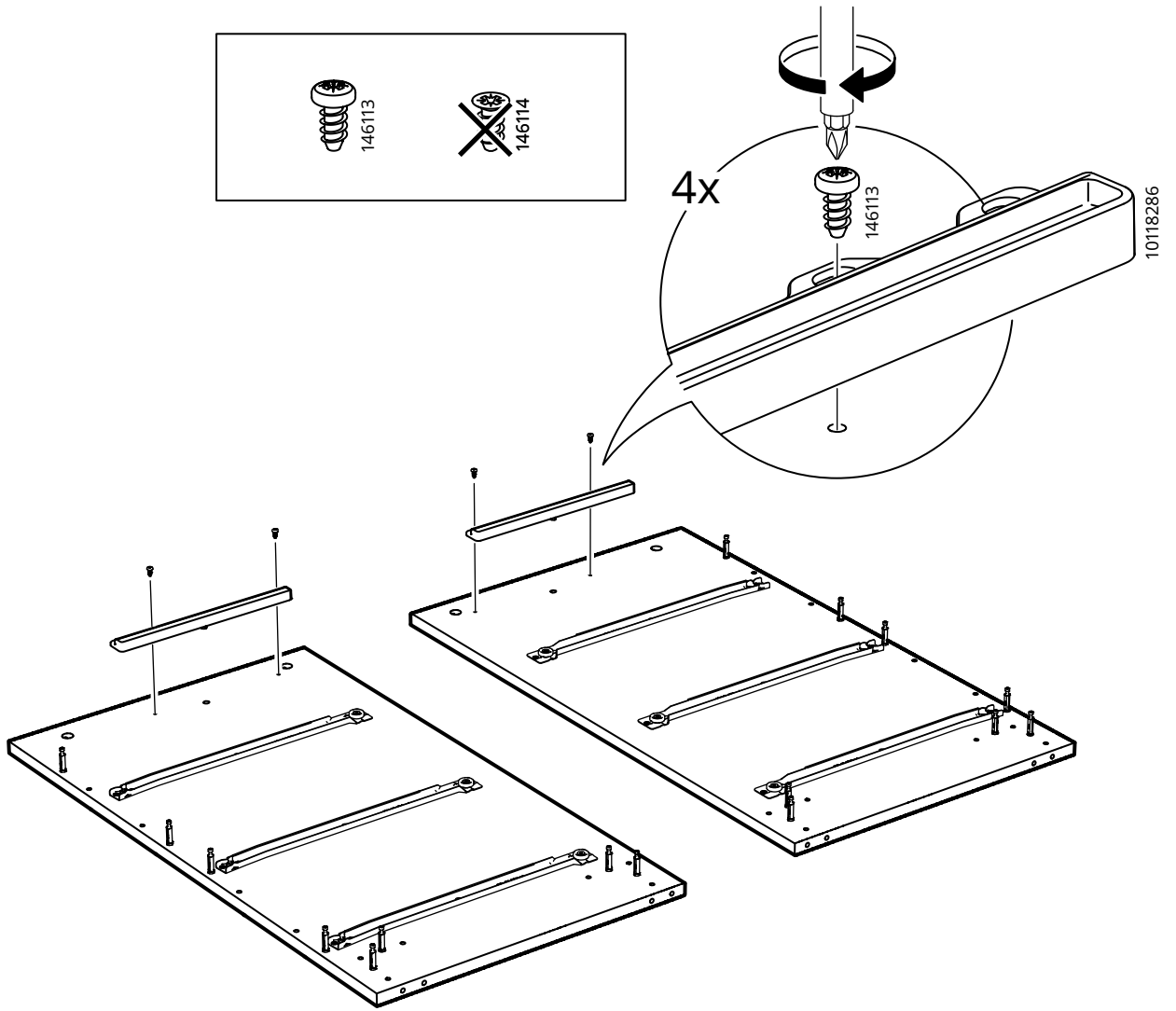

4

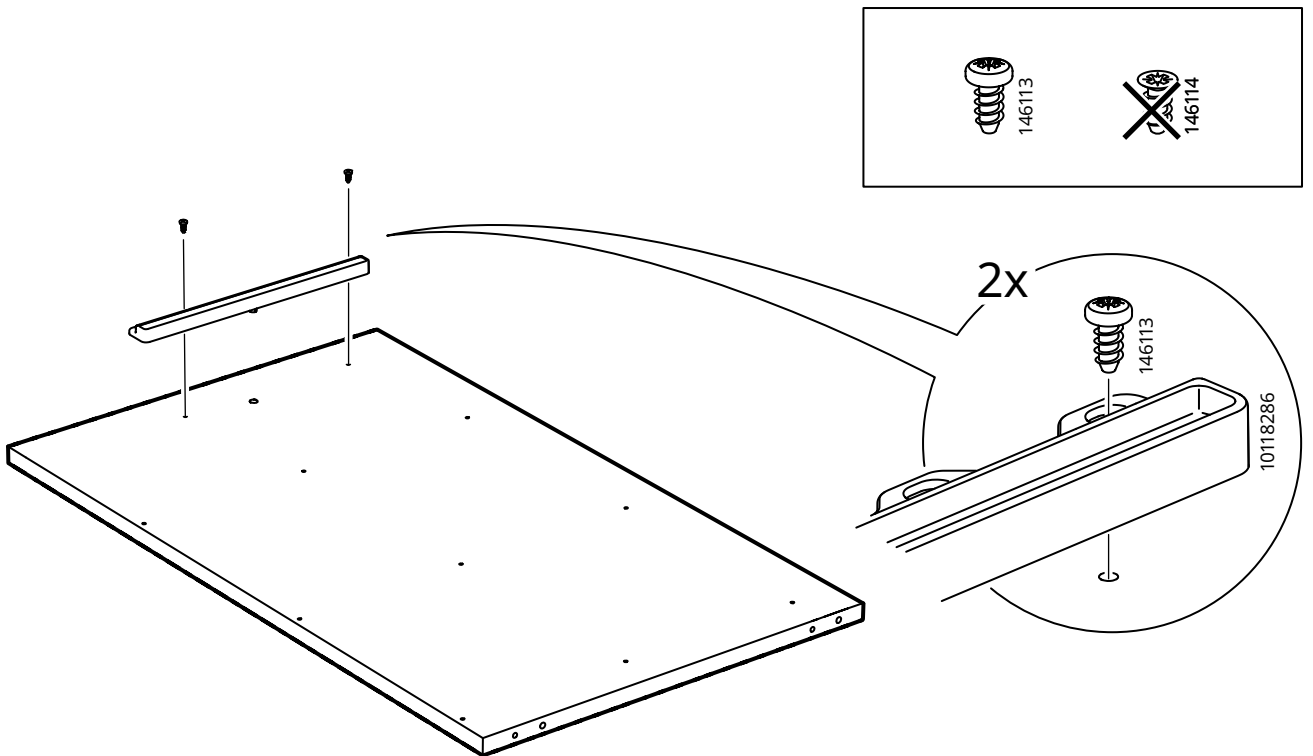

5

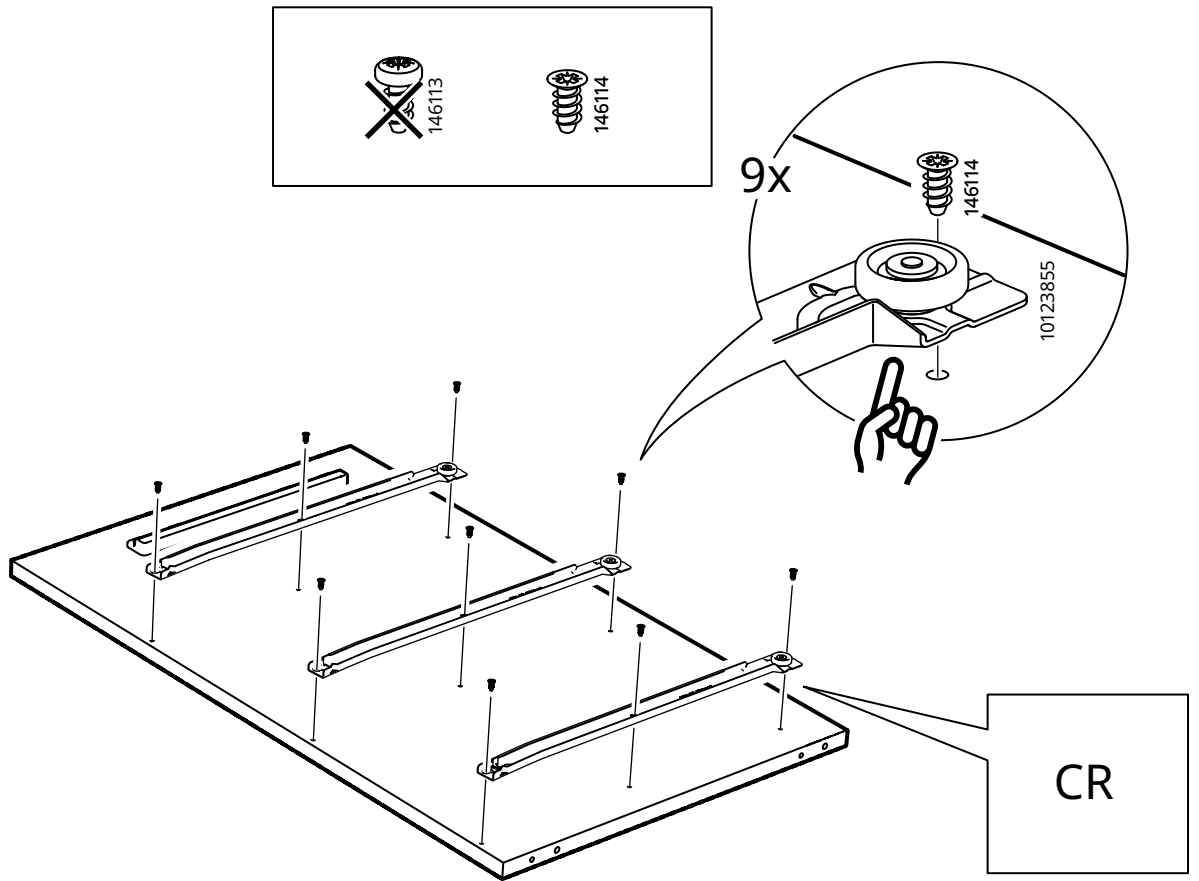

6

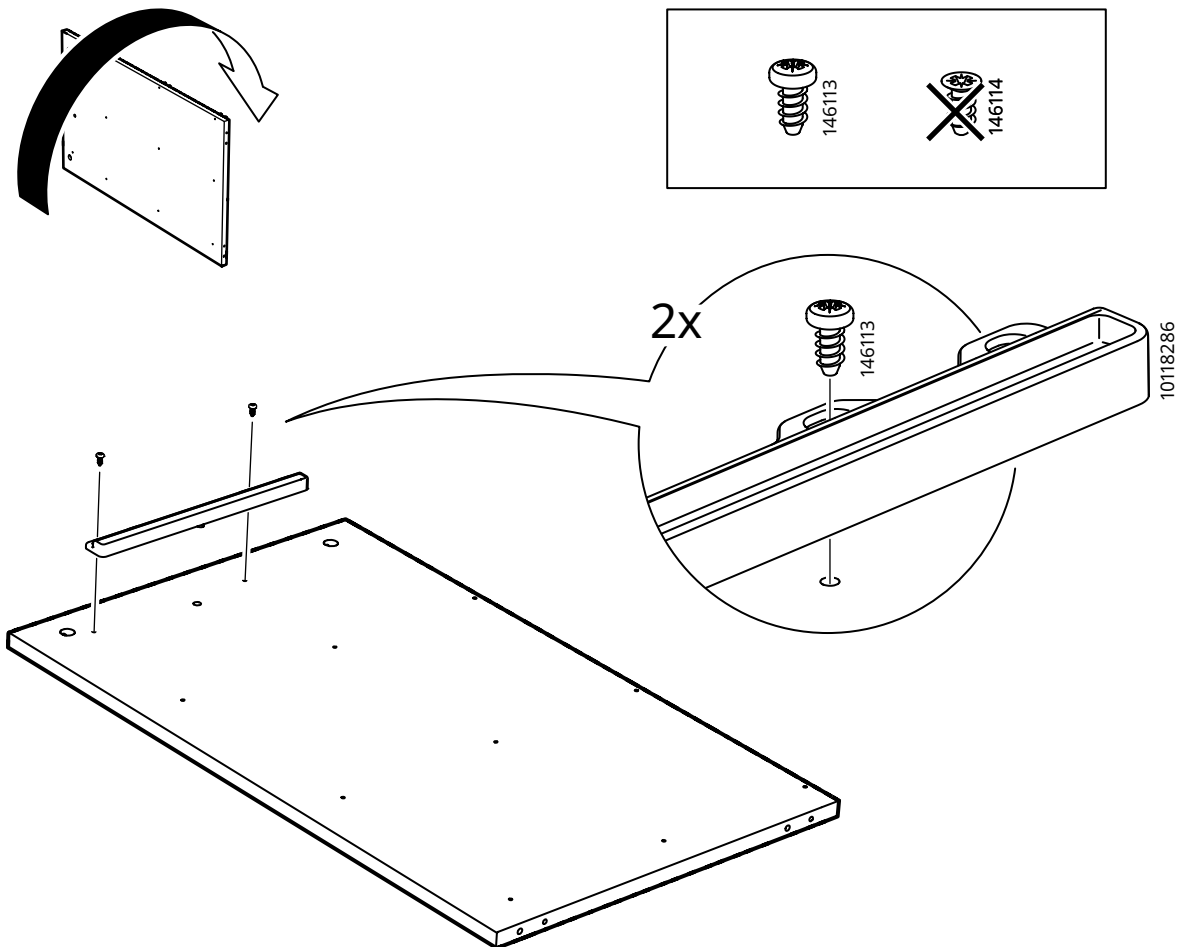

7

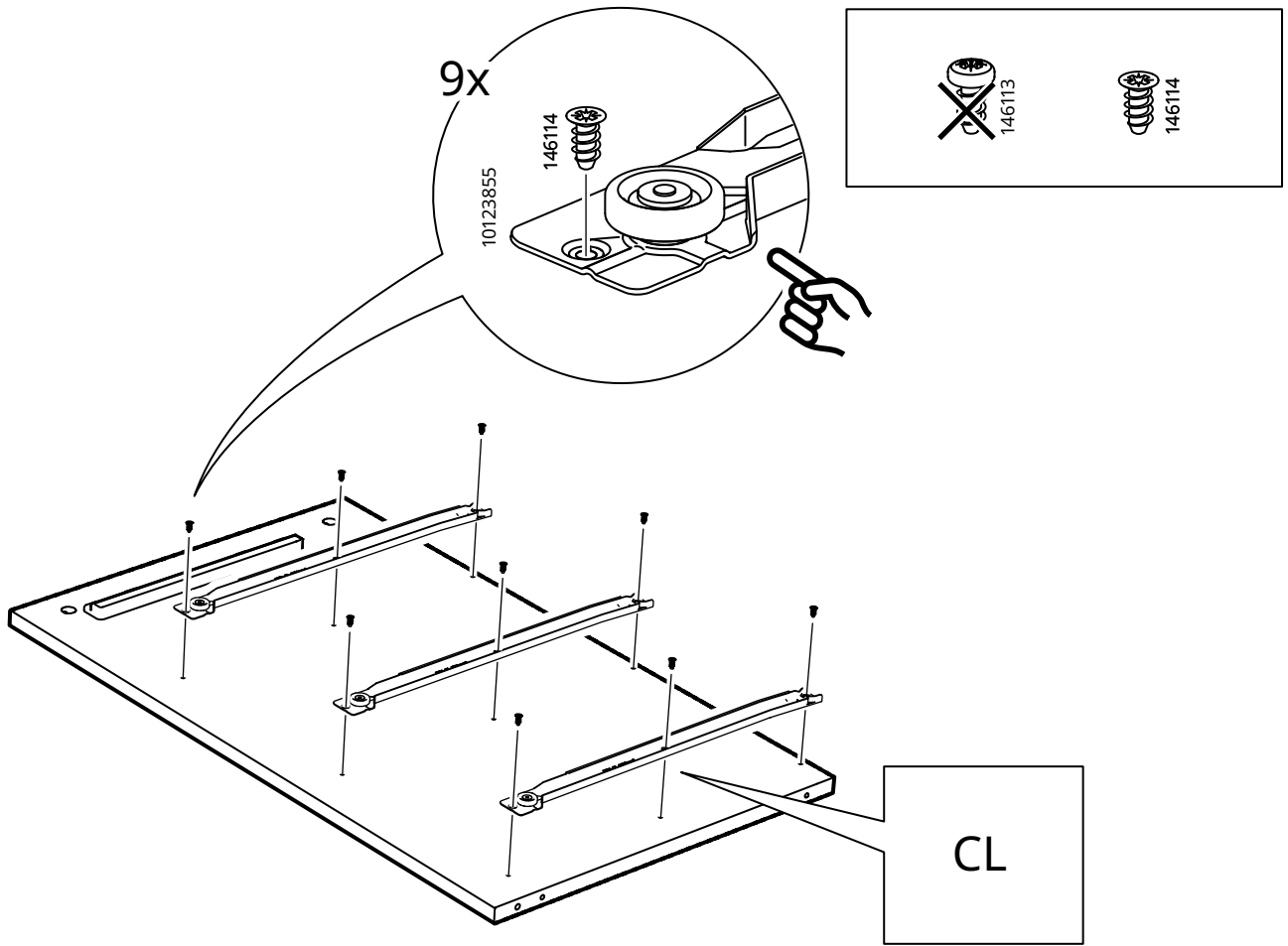

8

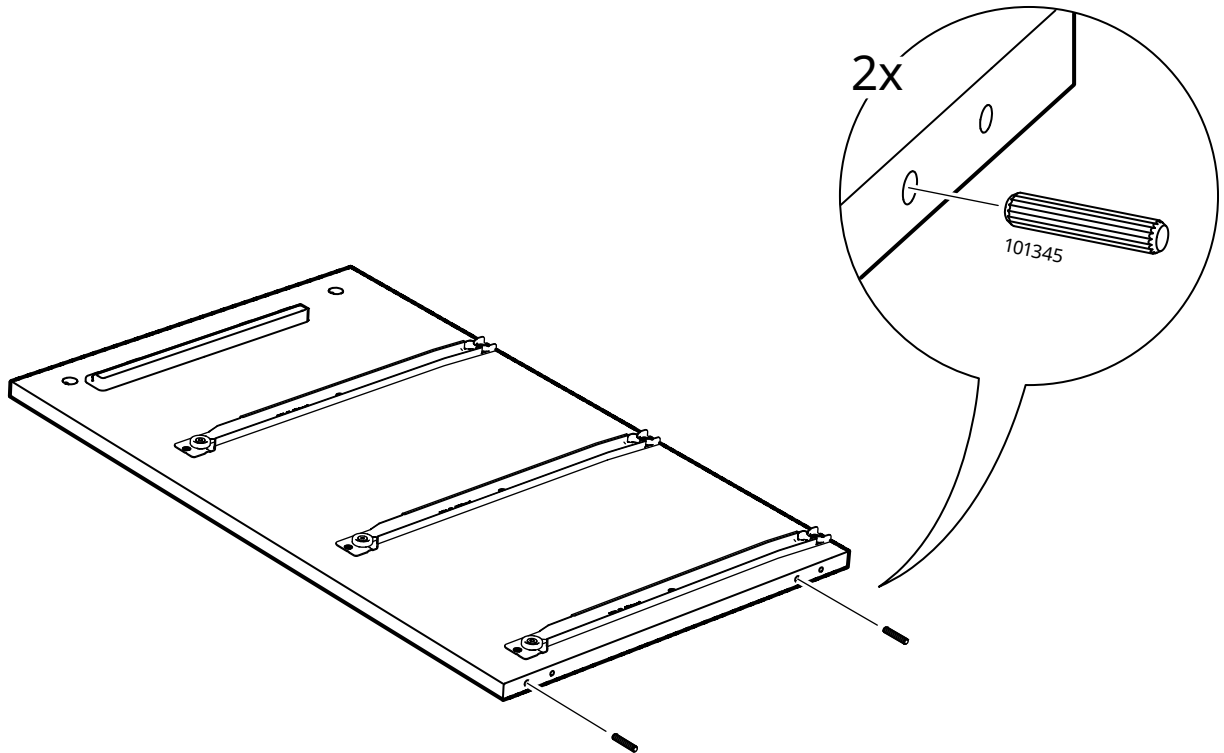

9

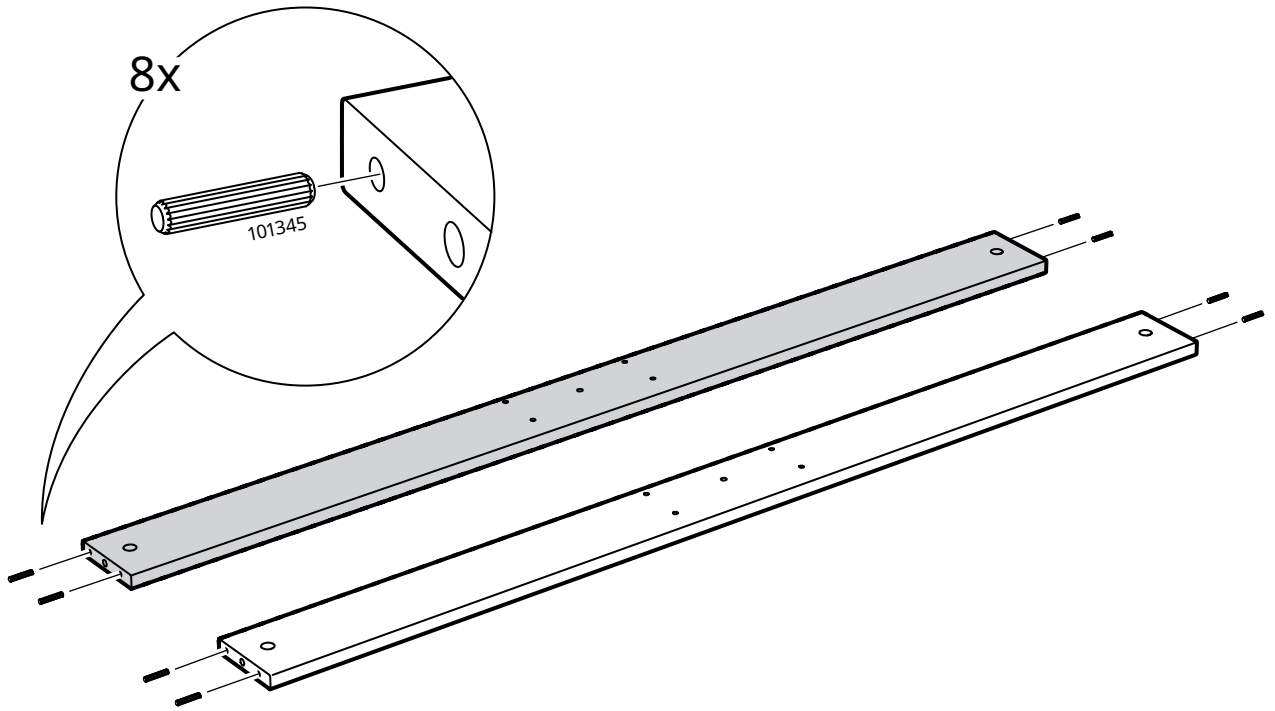

10

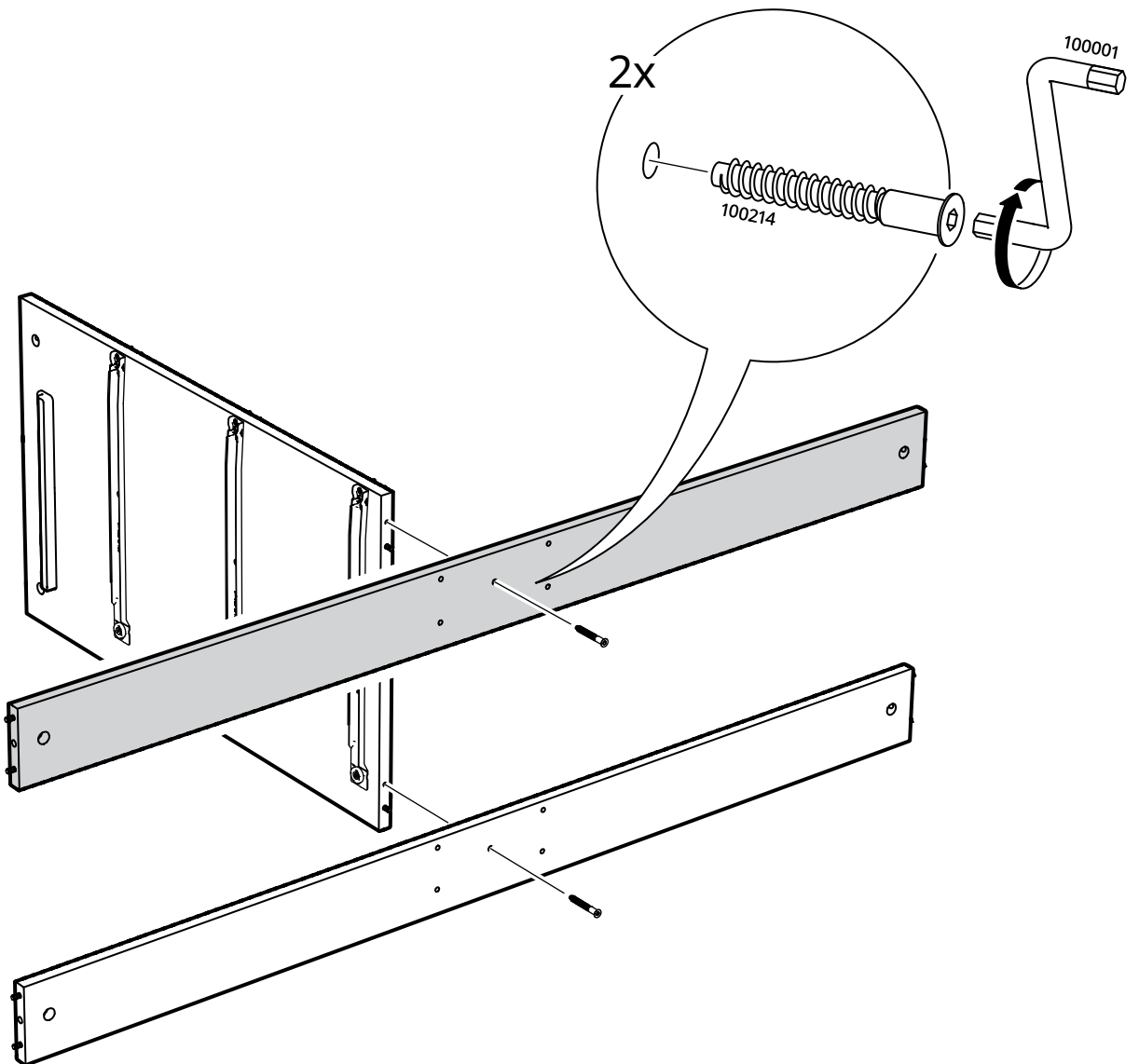

11

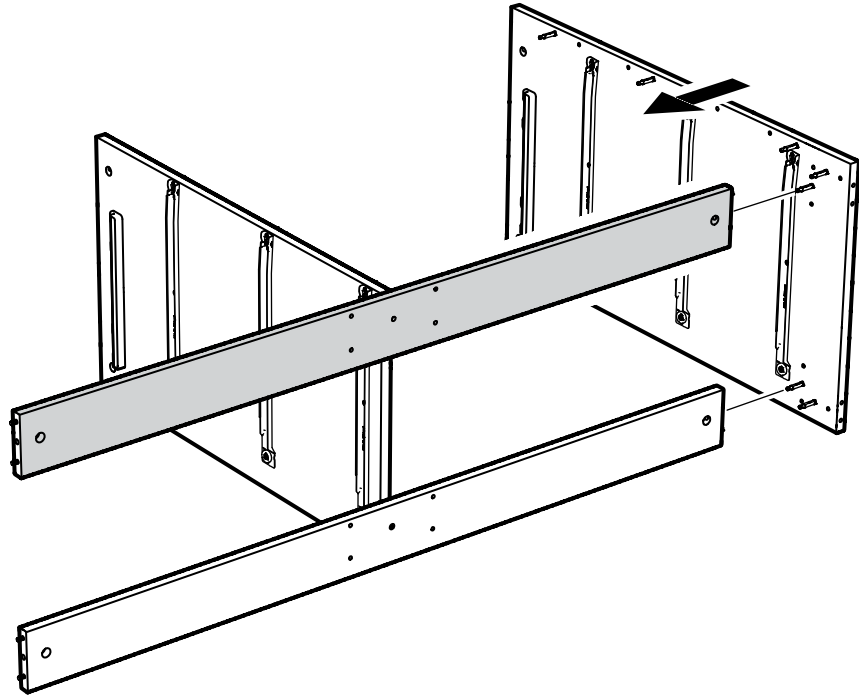

12

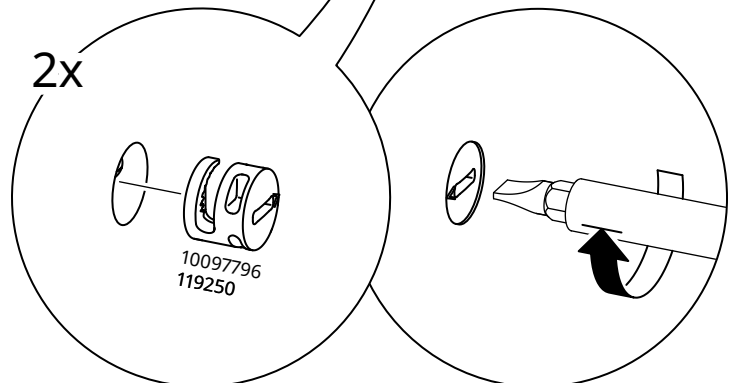
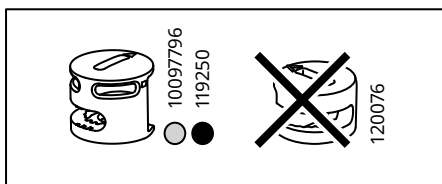
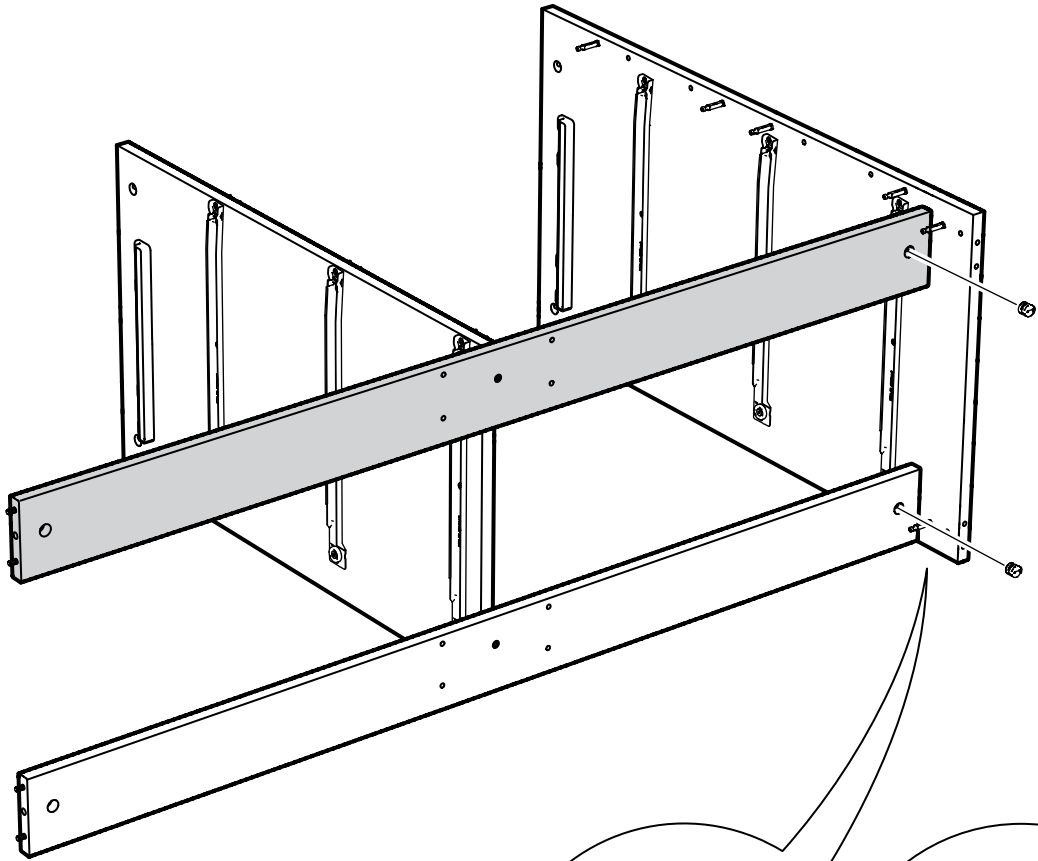

13

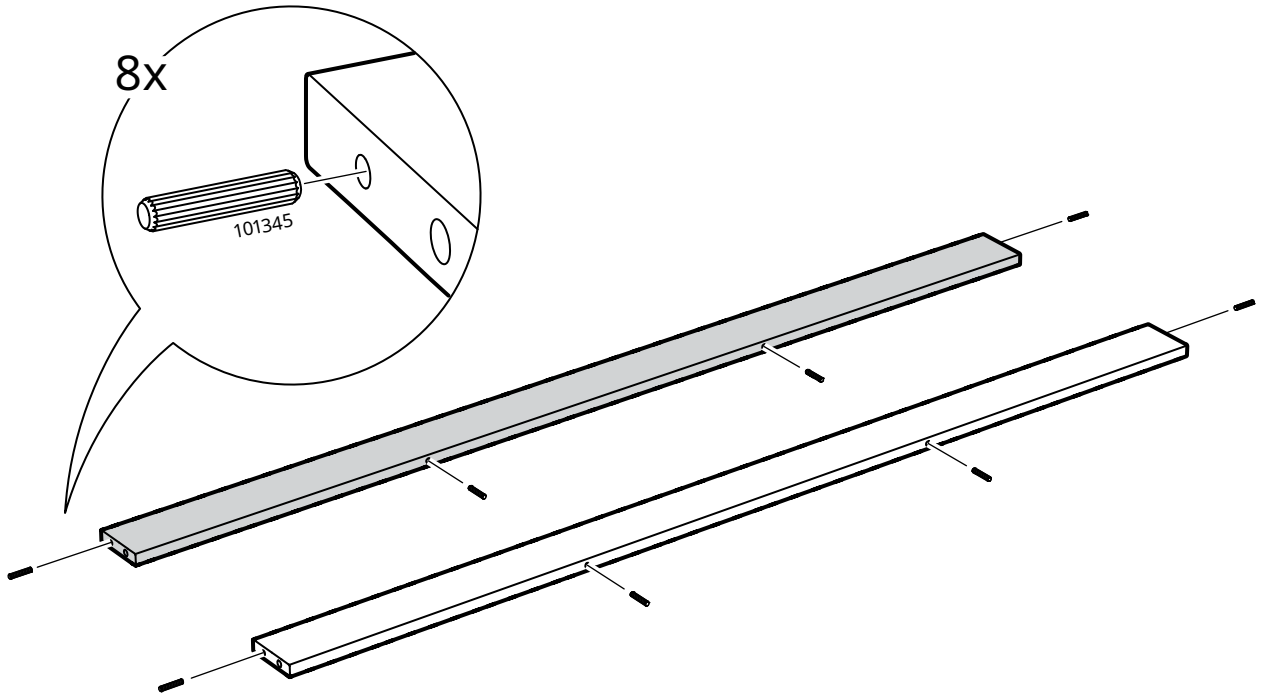

14

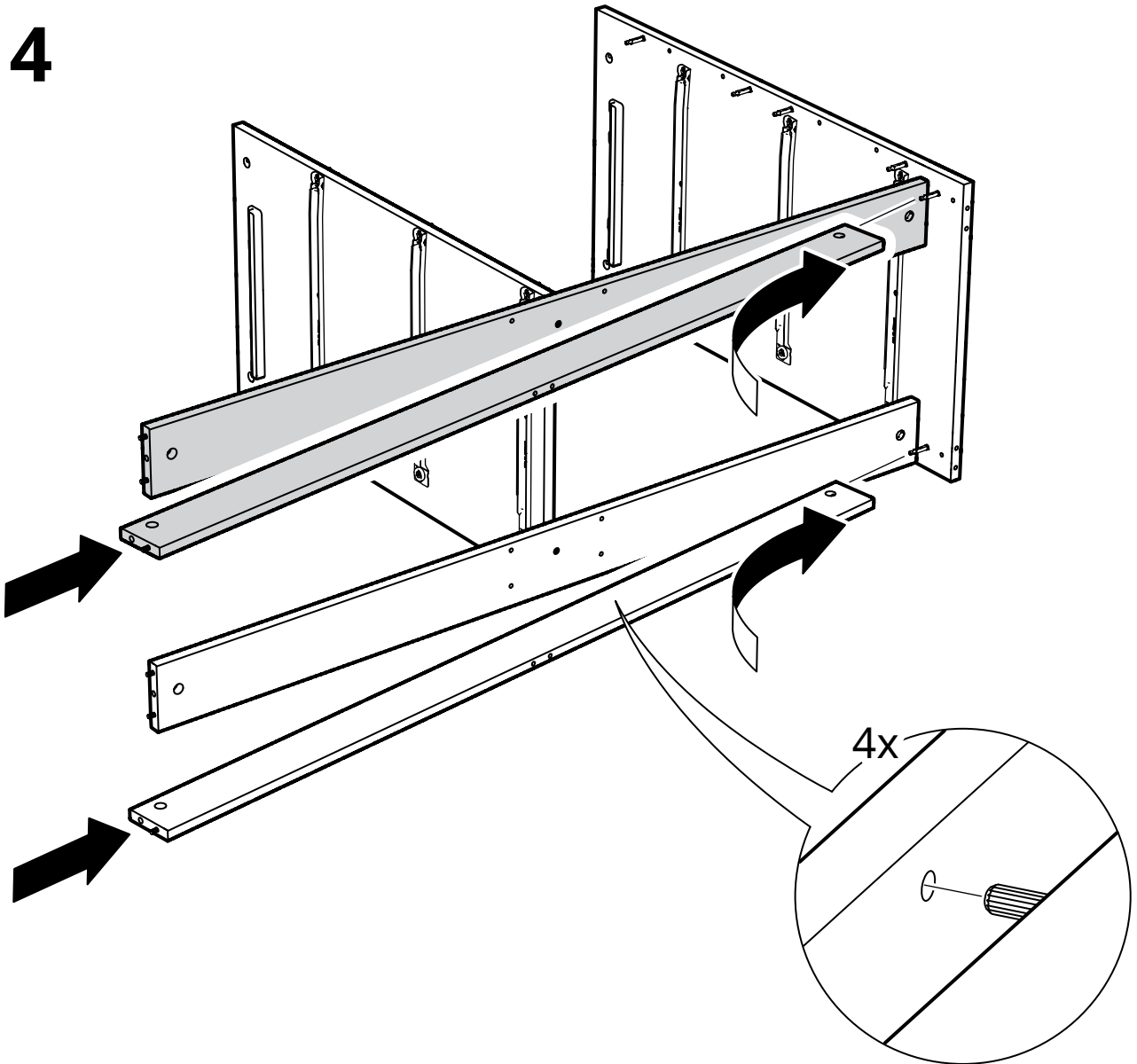

15

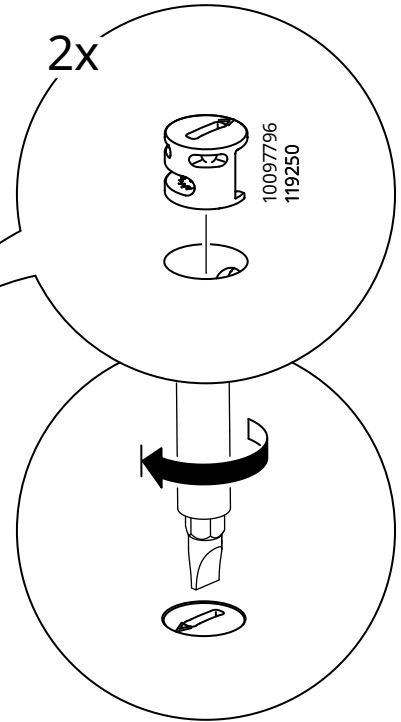
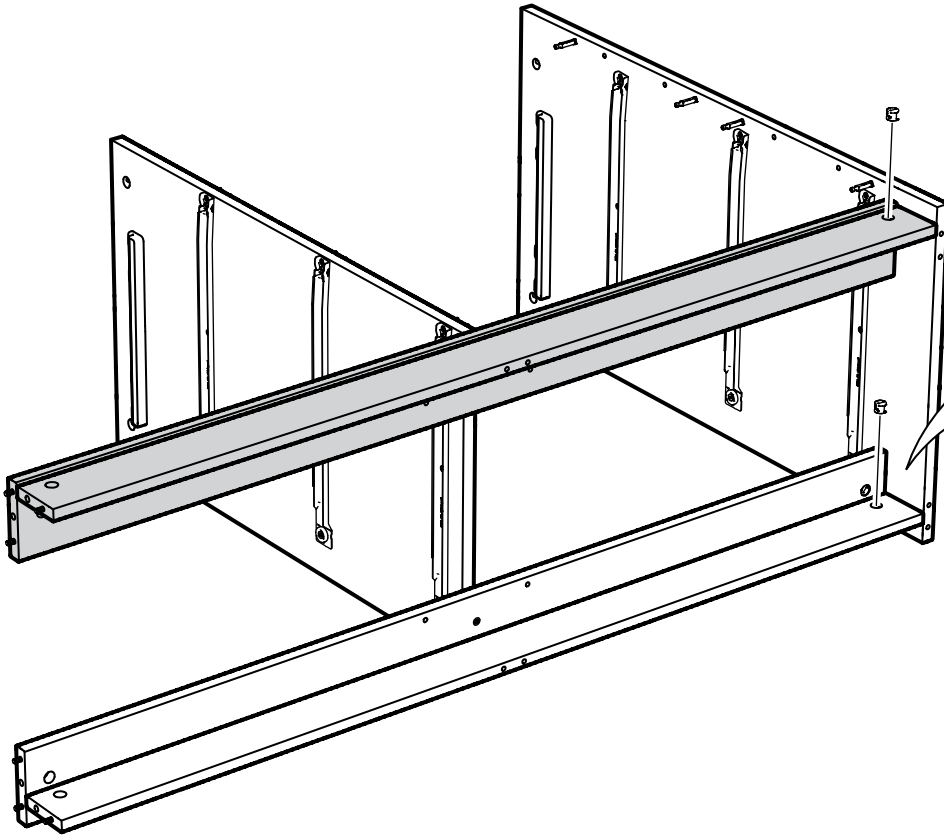
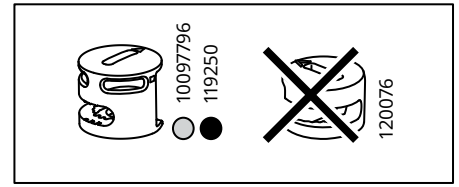

16

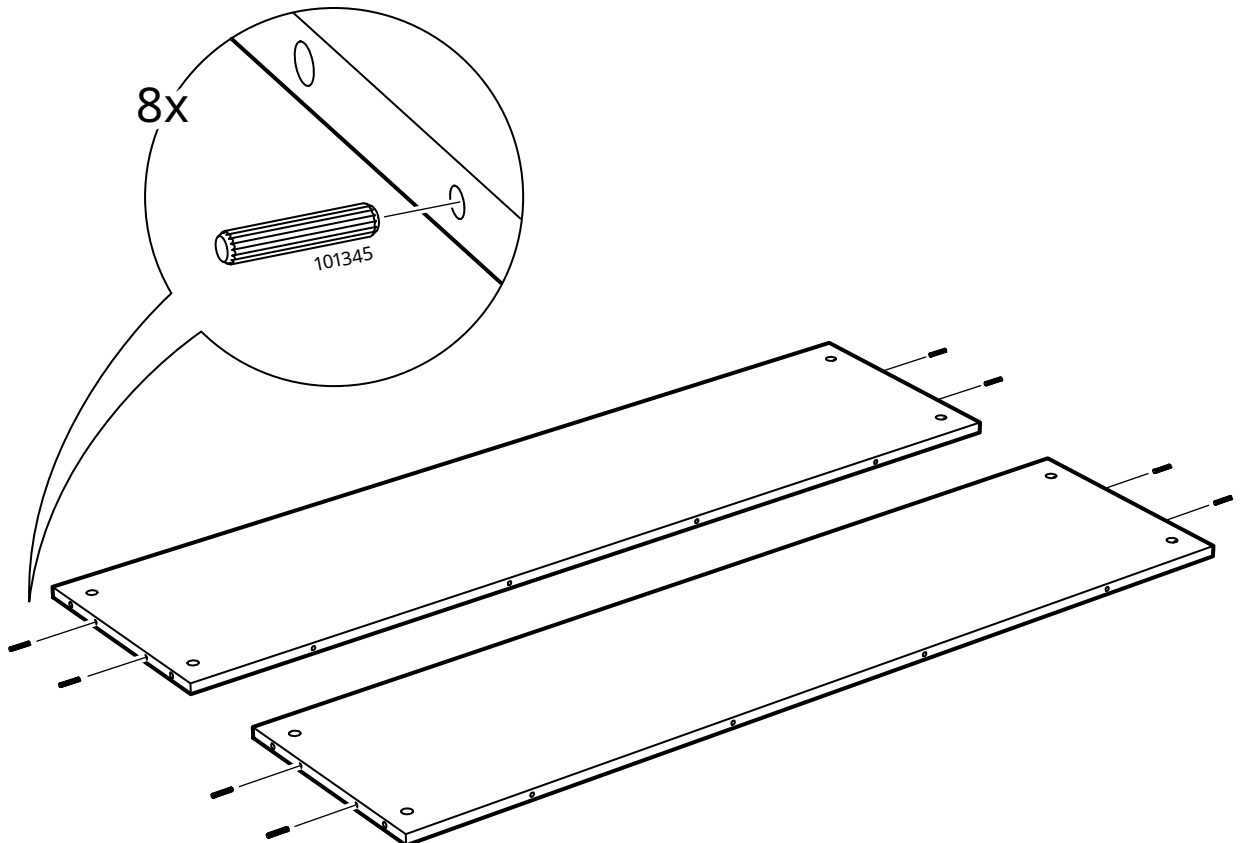

17

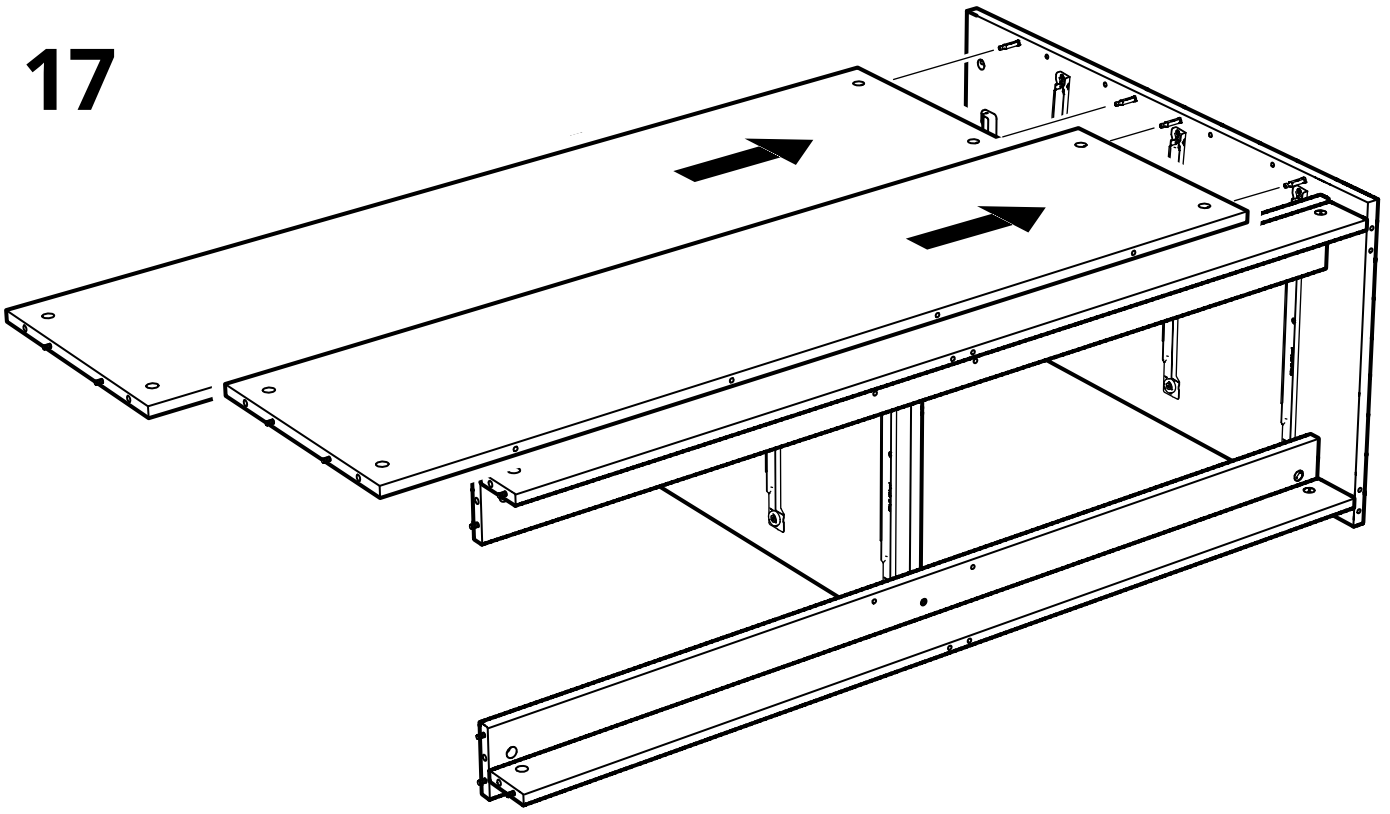

18

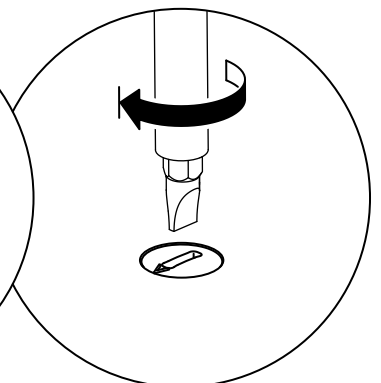
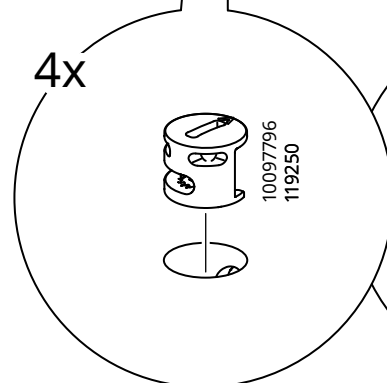
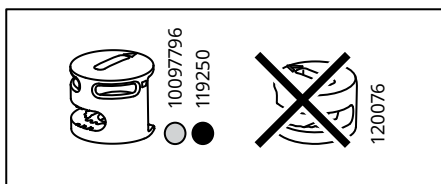
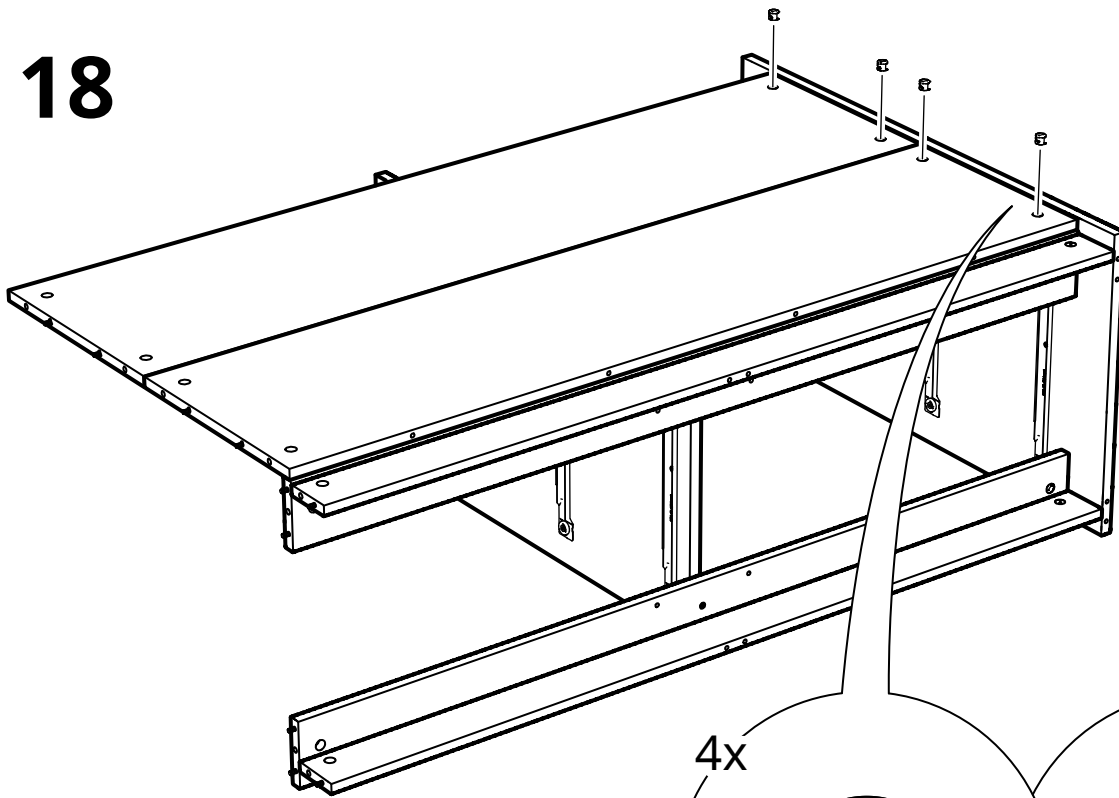

19

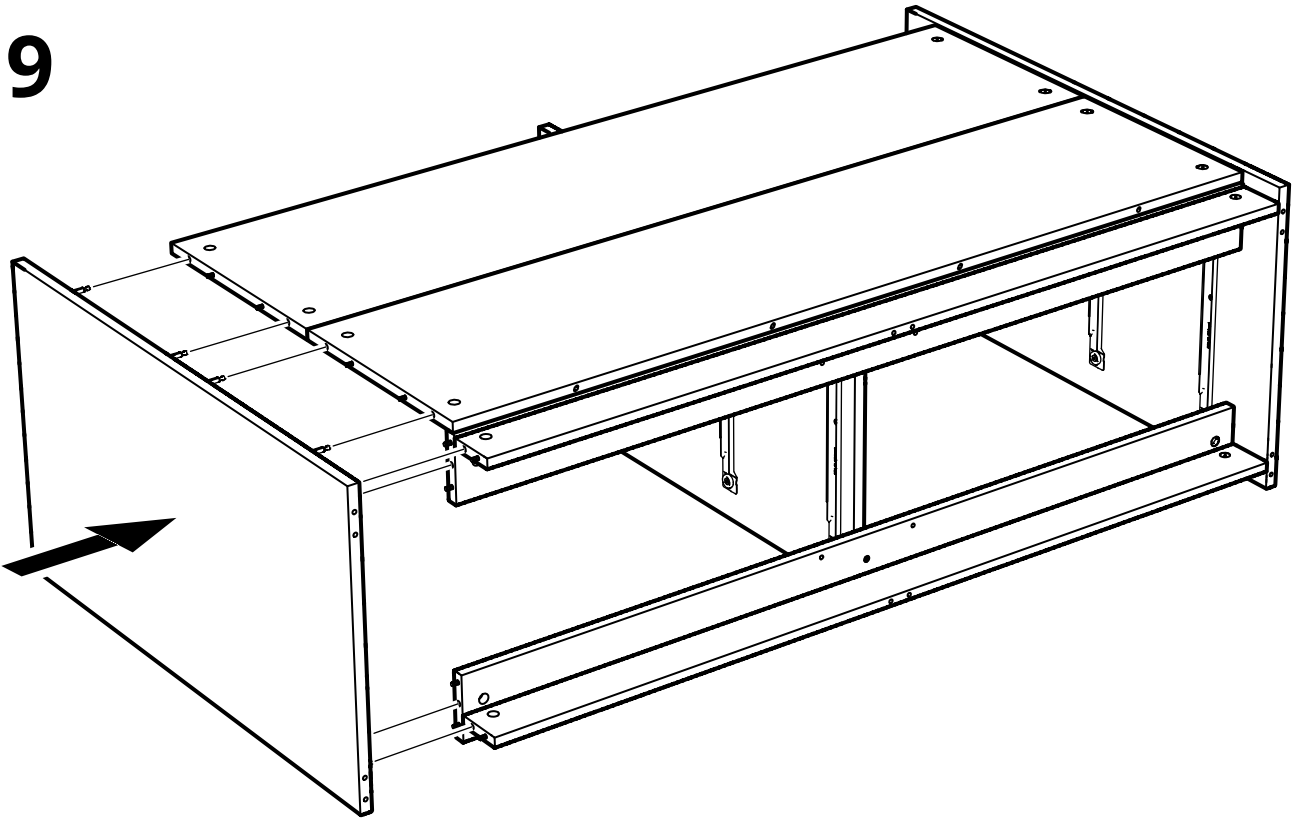

20

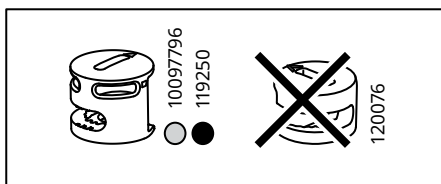
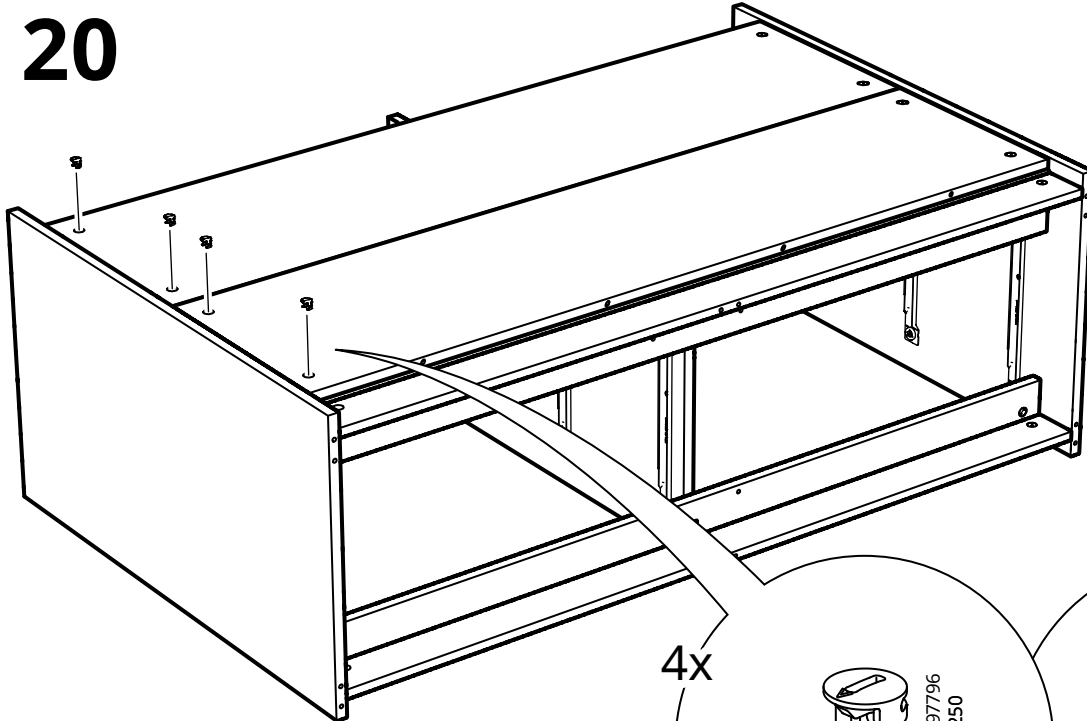

4x

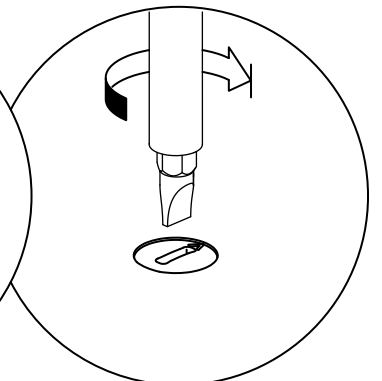
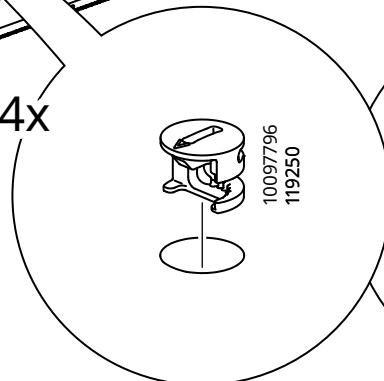

21

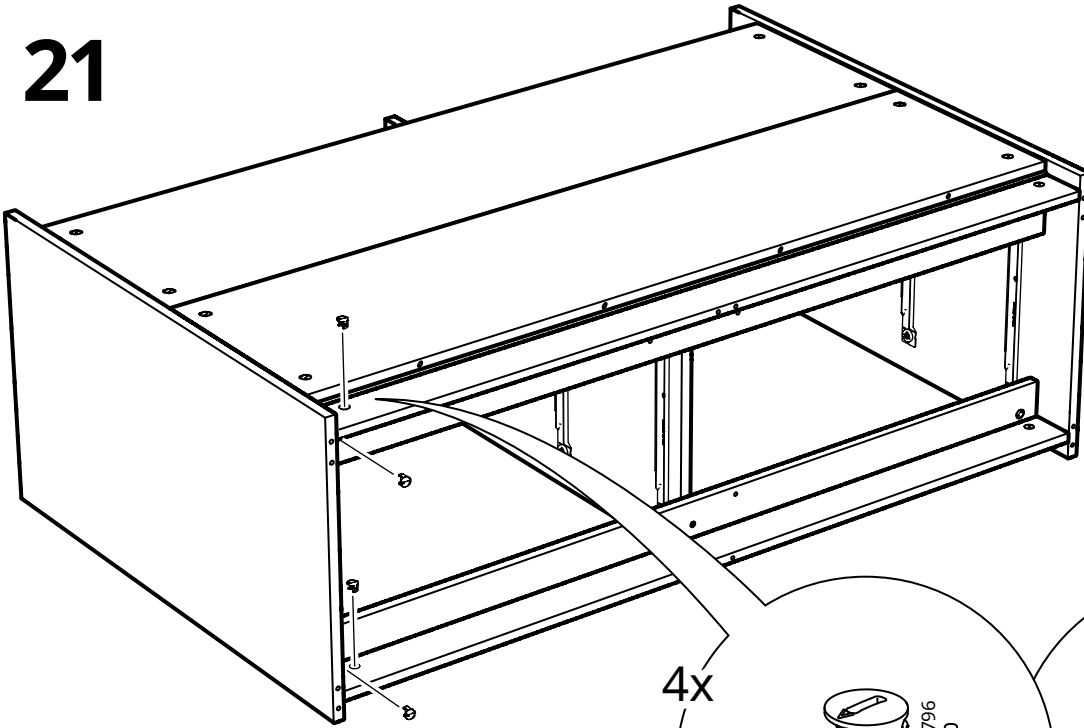

4x

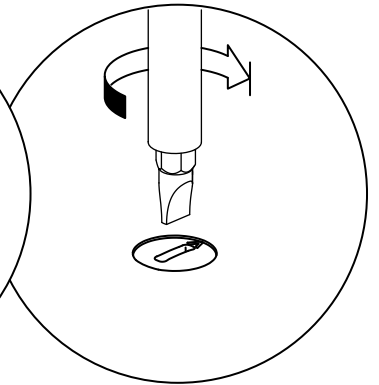
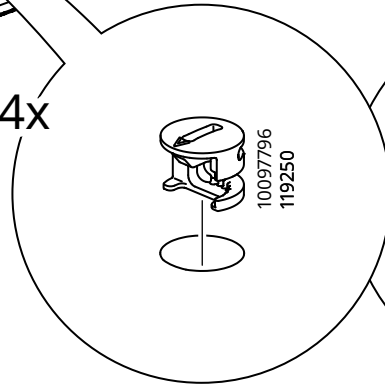
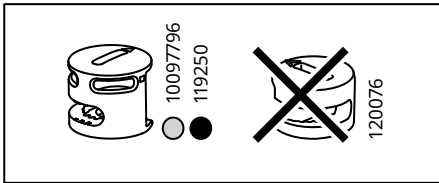

22

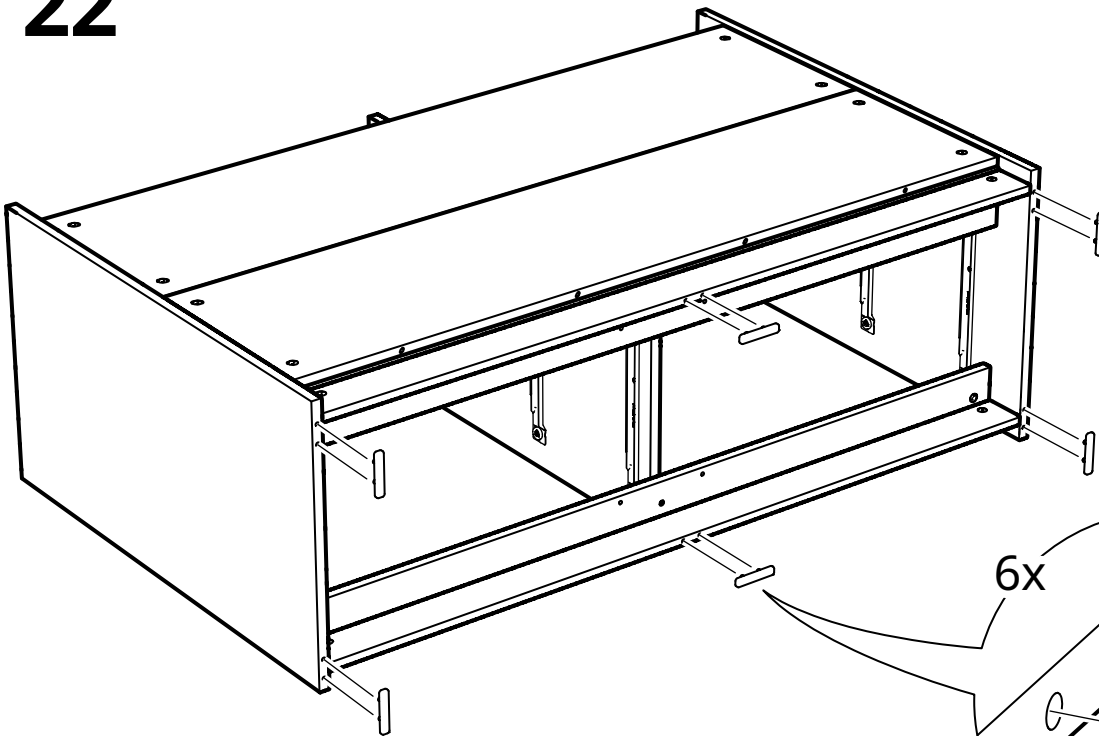

6x

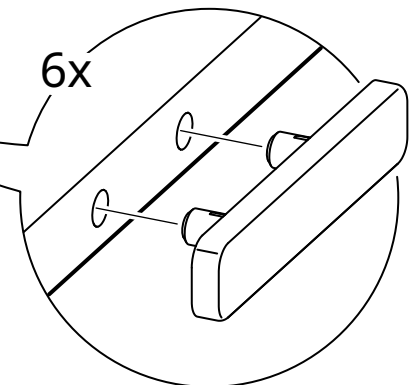

23

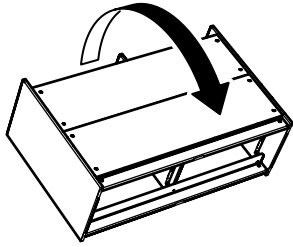

8x

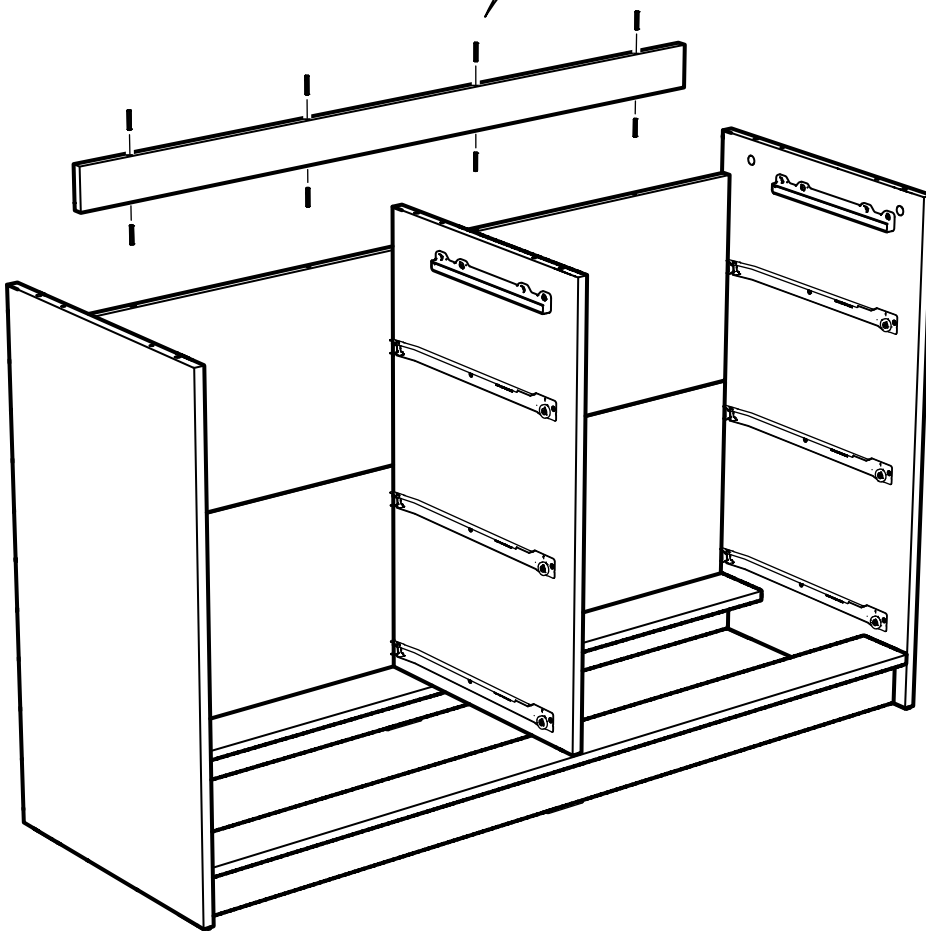
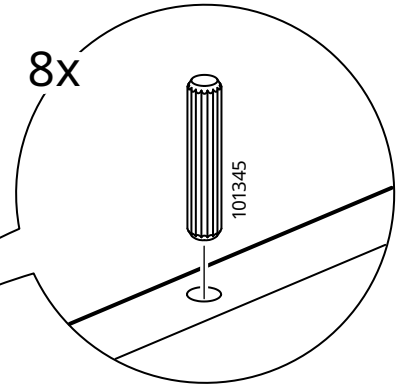

24

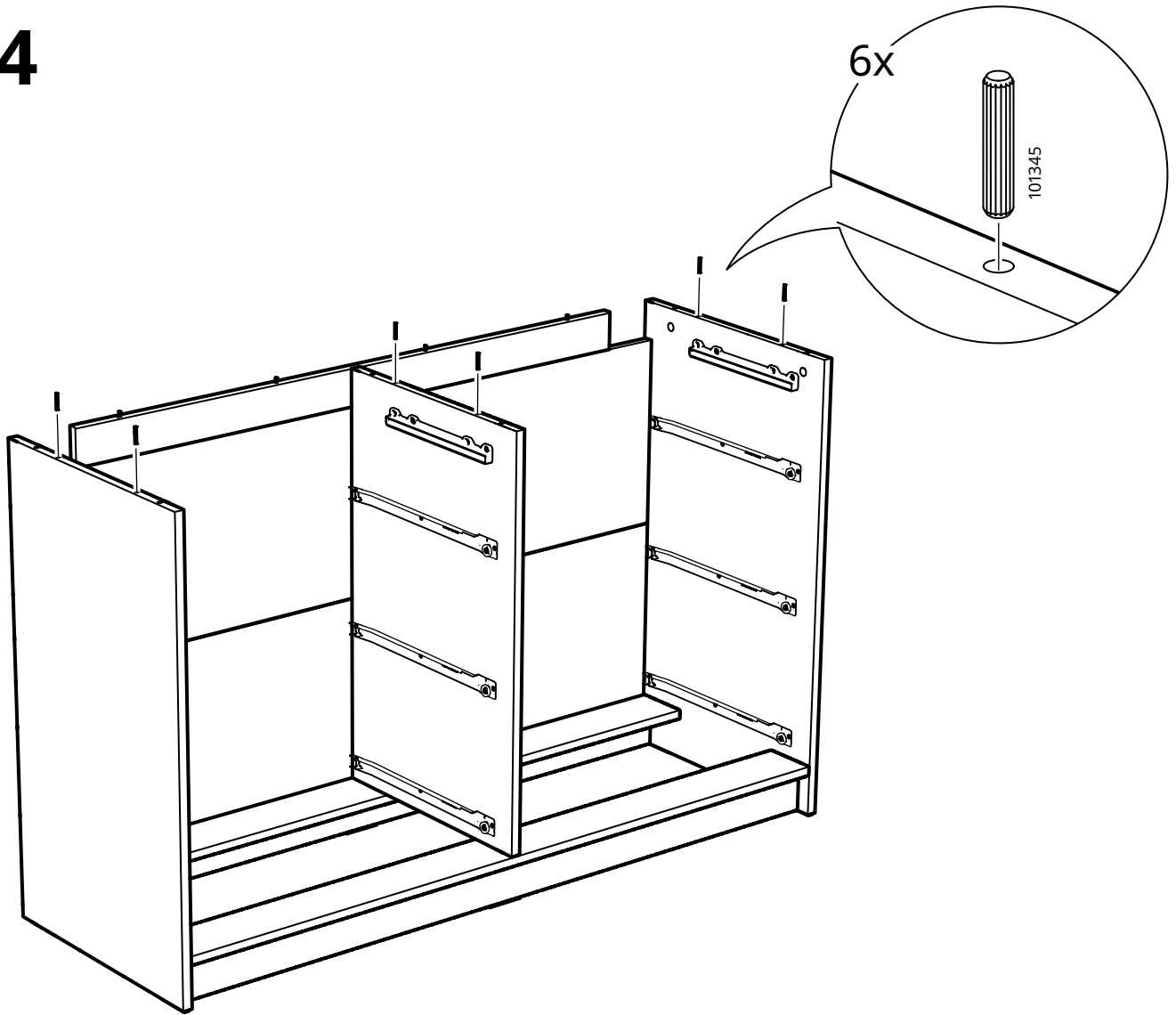

25

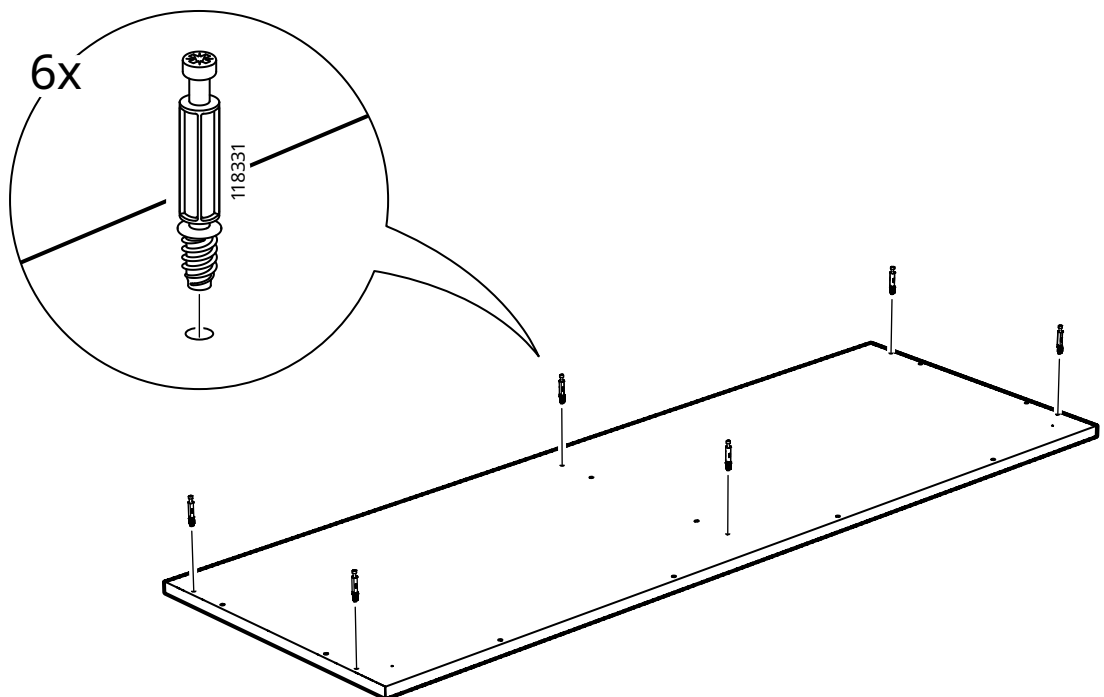

26

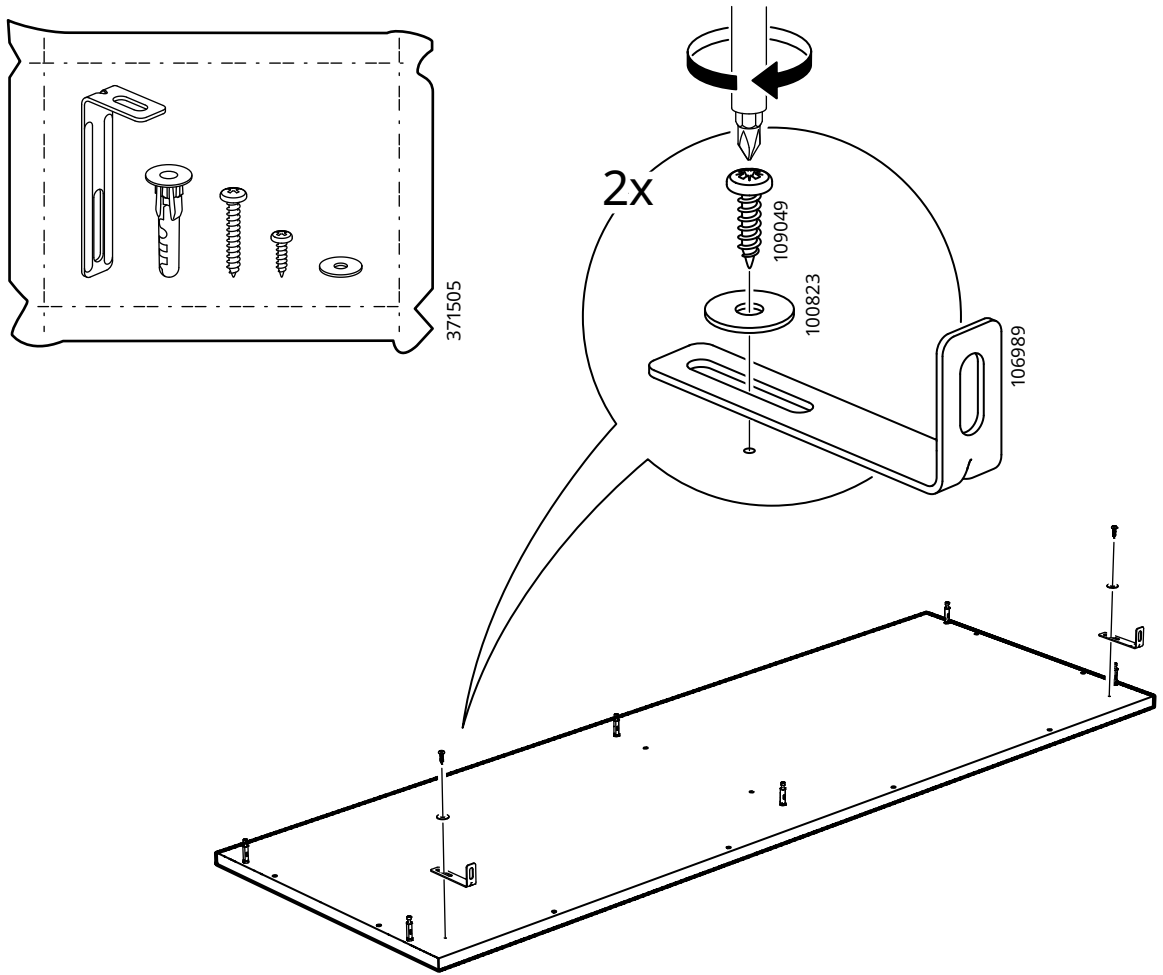

27

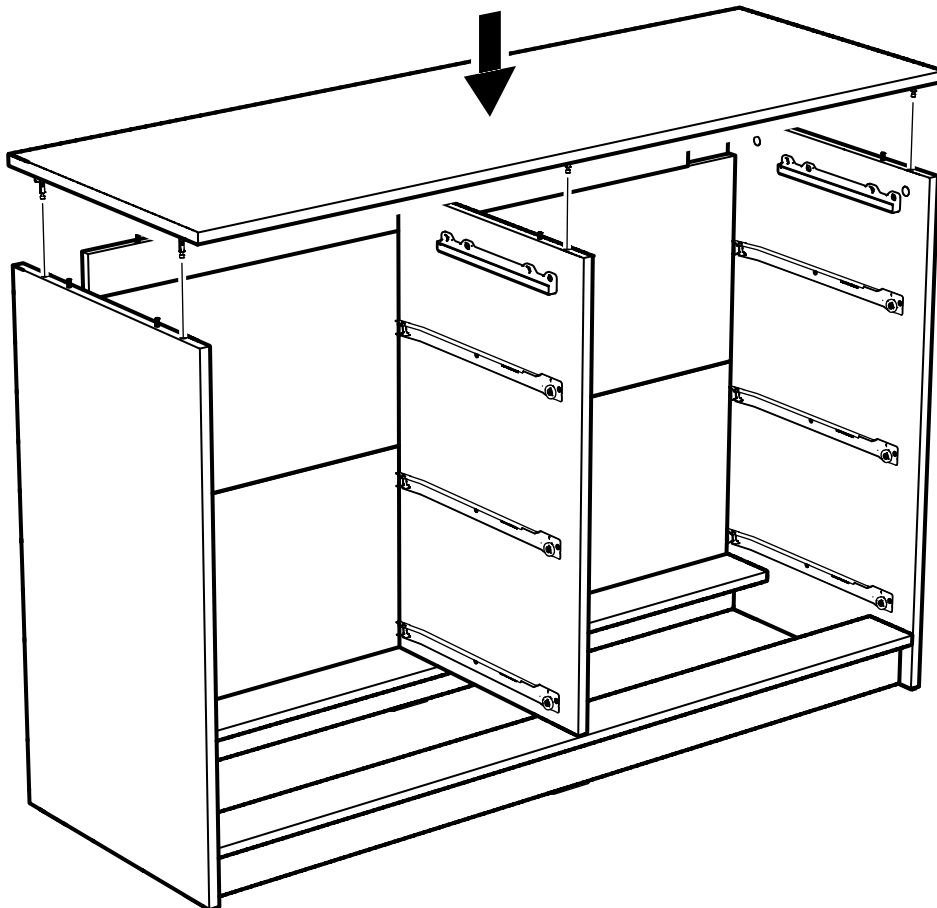

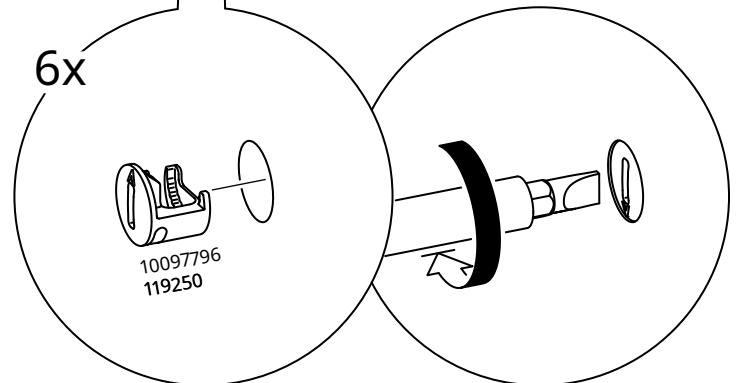
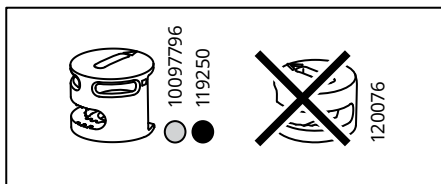
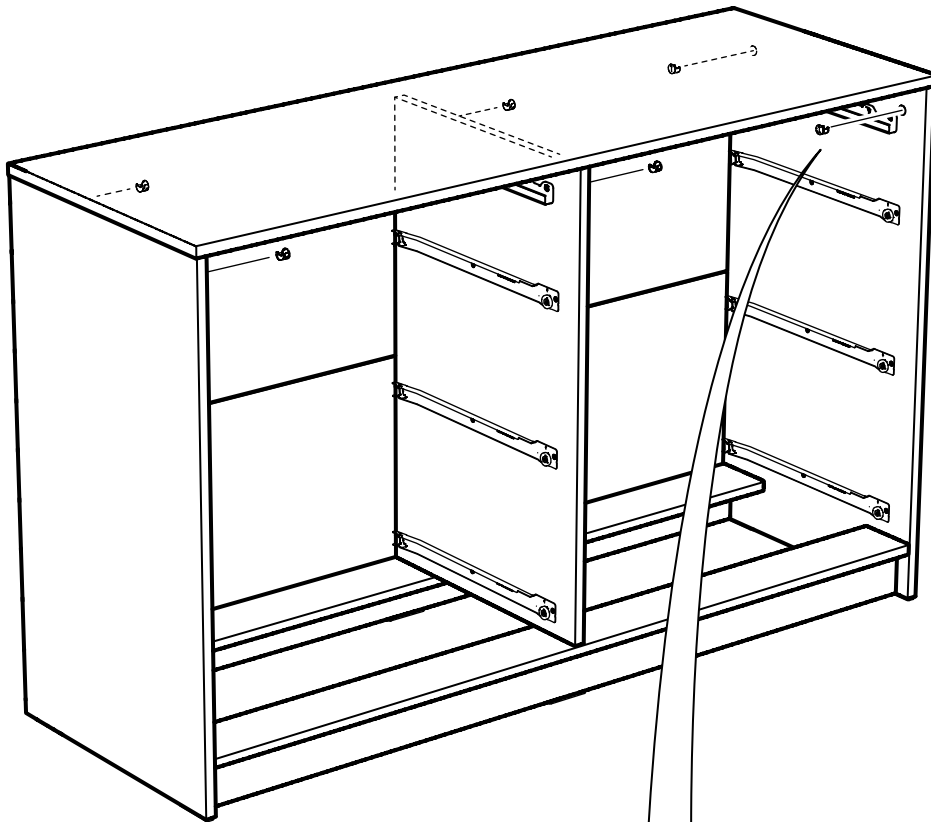

29

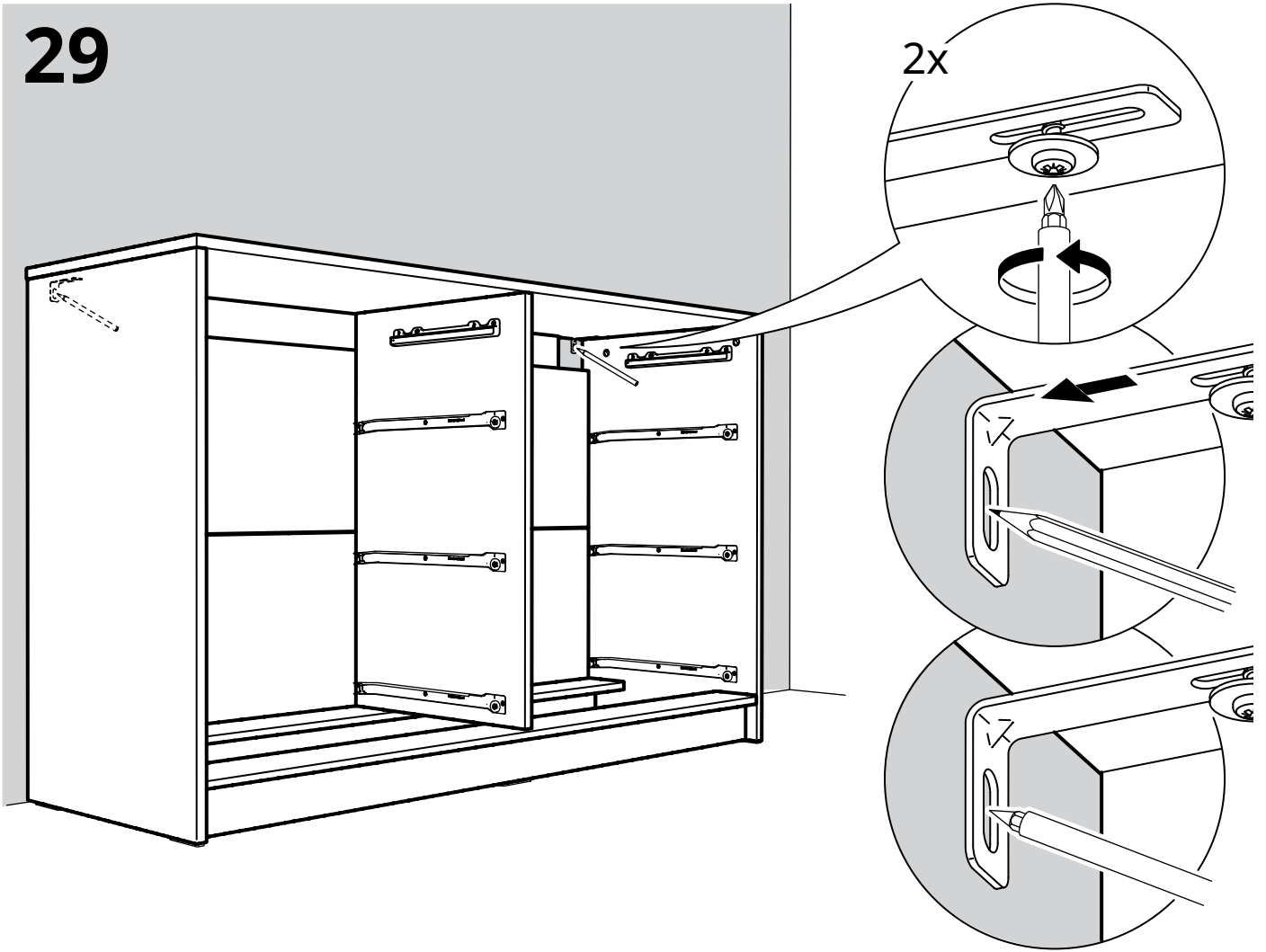

30

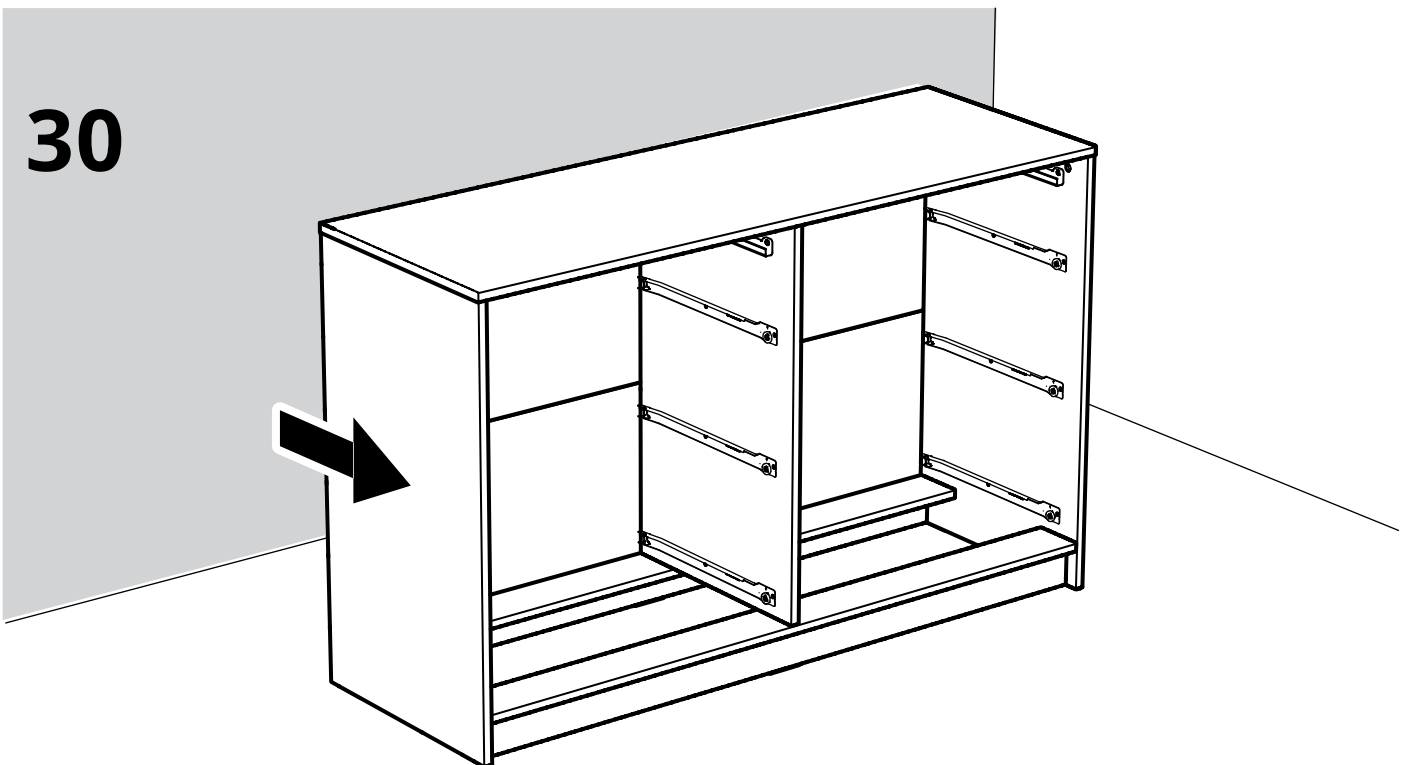



www.IKEA.com/secure-it

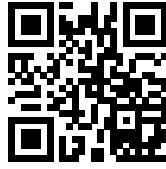

www.IKEA.cn/secure-it

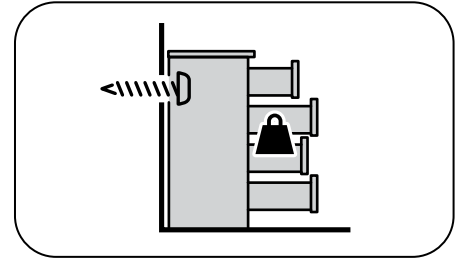

31

English

The screw(s) and plug(s) supplied can be used with most solid (A) and hollow (B) walls. For solid wood (C) use the screw(s) without plug(s). If you are uncertain, seek professional advice.

Deutsch

Das beigelegte Befestigungsmaterial kann für die meisten Massiv- (A) und Hohlwände (B) benutzt werden. Für Massivholzuntergrund (C) Schraube/n ohne Dübel verwenden. Bei Unsicherheit immer fachlichen Rat einholen.

Français

Les vis et les chevilles fournies peuvent être utilisées avec la plupart des murs pleins (A) ou des murs creux (B). Pour le bois massif (C), utiliser les vis sans les chevilles. En cas de doute, adressez-vous à un professionnel qualifié.

Nederlands

De meegeleverde schroef/schroeven en plug/pluggen zijn geschikt voor de meeste massieve (A) en holle (B) wanden. Voor massief hout (C) gebruik schroeven zonder plug. Neem bij twijfel contact op met de vakhandel.

Dansk

Den/de leverede skrue(r) og rawplug(s) kan bruges til de fleste massive (A) og hule (B) vægge. Til massivt træ (C) bruges skrue(n) uden rawplug(s). Kontakt en fagmand, hvis du er i tvivl.

Íslenska

Meðfylgjandi skráfur og tappa henta flestum veggjum hvort sem þeir eru gegnheilir (A) eða holir (B). Notaðu skráfur án tappa í gegnheilum (C) við. Leitaðu til fagaðila ef þú ert ekki viss um hvað festingar skal nota.

A

Ø 8 mm (5/16")

1

70 mm (2 3/4")

2

28

B

Ø 8 mm (5/16")

1

≈ 30 mm (≈ 1 1/4")

2

29

C

Ø 3 mm (1/8")

1

≈ 30 mm (≈ 1 1/4")

31

Norsk

Skrue(r) og plugg(er) som følger med, kan brukes til de fleste massive (A) og hule (B) vegger. For massivt tre (C) brukes skrue(r) uten plugg(er). Rådfør deg med fagfolk dersom du er usikker.

Suomi

Mukana tulevat ruuvit ja tulpat sopivat käytettäväksi useimmissa kiinteissä (A) ja onttorakenteisissa (B) seinissä. Käytä puurakenteisessa (C) seinässä ruuvia ilman tulppaa. Jos et ole varma oikeasta kiinnitystavasta, pyydä apua rautakaupasta.

Svenska

Medföljande skruv(ar) och plugg(ar) kan användas för de flesta solida (A) och ihålliga (B) väggar. För massivt trä (C) använd skruv utan plugg. Om du är osäker, sök professionell rådgivning.

Česky

Dodávané šroubky a hmoždinky můžete používat na většině plných (A) a dutých (B) stěn. Na masivní dřevo (C) použijte šroubky bez hmoždinek. Pokud si nejste jistí, zeptejte se odborníka.

Español

Los tornillos y tacos incluidos se pueden utilizar en la mayor parte de las paredes sólidas (A) o huecas (B). Para la madera maciza (C), usa los tornillos sin tacos. Si tienes dudas, acude a un experto.

Italiano

Le viti e i tasselli forniti sono utilizzabili con la maggior parte delle pareti piene (A) e cave (B). Per il legno massiccio (C), usa le viti senza i tasselli. Se hai dubbi, rivolgiti a un esperto.

Magyar

A mellékelt csavarok és tiplik a legtöbbször (A) és üreges (B) fal típus esetén használhatók. Tömör fa (C) esetén ne használj tiplit. Ha kérdés merülne fel benned, vedd fel a kapcsolatot egy szakemberrel.

Polski

Dołączone śruby i kołki można zastosować w większości pełnych (A) i pustych (B) ścian. W przypadku litego drewna (C) należy użyć śrub bez kołków. W razie wątpliwości zwróć się o pomoc do profesjonalisty.

Eesti

Kaasas olevad kruvid ja tüüblid sobivad kasutamiseks enamike tahkete (A) ja õõnsate (B) seintega. Täispuidu (C) puhul kasuta kruvisid ilma tüübliteta. Kui sa ei ole kindel, palu abi professionaalilt.

Latviešu

Komplektā iekļautās skrūves un dībeļus var izmantot vairumam sienu, kas veidotas no blīviem (A) vai dobiem (B) blokiem. Kokam (C) izmanto skrūves bez dībeļiem. Nepieciešamības gadījumā vērsties pēc padoma pie speciālista.

Lietuvių

Rinkinyje esantys varžtai ir kaiščiai tinka daugeliui vientisų (A) ir tuščiaidurių (B) sienų. Tvirtinimui prie medinės sienos (C) kaiščiai nereikalingi, tik varžtai. Jei turite klausimų dėl tvirtinimo, kreipkitės patarimo į specialistą.

Portugues

Os parafusos e os pinos fornecidos podem ser usados na maior parte das paredes maciças (A) e ocas (B). Para madeira maciça (C), use parafusos sem pinos. Se não tiver a certeza, peça ajuda a um técnico especializado.

Româna

Șuruburile și diblurile incluse pot fi folosite cu majoritatea pereților plini (A) și cu perforații (B). Pentru lemn masiv (C) folosește șuruburi fără dibluri. În caz de dubiu, consultă un specialist calificat.

Slovensky

Dodávané skrutky a hmoždinky možno používať na väčšine plných (A) a dutých (B) stien. Na masívne drevo (C) použijte skrutky bez hmoždinky. Ak si nie ste istí, opýtajte sa odborníka.

Български

Приложения(ите) винт(ове) и дюбел(и) могат да се използват с повечето твърди (A) и кухи (B) стени. За масивна дървесина (B) използвайте винта(ове) без дюбела(и). Ако не сте сигурни, поискайте съвет от професионалист.

Hrvatski

Vijak (vijci) i tipla (tiple) mogu se upotrebljavati za većinu punih (A) i šupljih (B) zidova. Za puno drvo (C) upotrebljavati vijak (vijke) bez tipla (tipli). U slučaju nedoumice, zatražiti stručni savjet.

Ελληνικά

Η βίδα(ες) και τα ούπα μπορούν να χρησιμοποιηθούν στα περισσότερα είδη τοίχου. Για τοίχο από μασίφ ξύλο χρησιμοποιείστε τη βίδα(ες) χωρίς ούπα. Αν δεν είστε σίγουροι, αναζητήστε βοήθεια από επαγγελματία.

Українська

Шуруп(и) та дюбель(и), що додаються, підходять для більшості міцних (A) та порожнистих (B) стін. Для міцних (C) стін використовуйте шуруп(и) без дюбеля(ів). Якщо ви не впевнені, зверніться до спеціаліста.

Srpski

Zavrtnaj (zavrtnji) i tipl (tiplovi) mogu se upotrebljavati za većinu punih (A) i šupljih (B) zidova. Za puno drvo (C) upotrebljavaj zavrtnaj (zavrtnje) bez tipla (tiplova). U slučaju nedoumice, zatraži stručni savet.

Slovenščina

Priloženi vijak(i) in zidni vložek oz. vložki so primerni za večino polnih (A) in votlih (B) zidov. Pri pritrdjevanju v masivni les (C) uporabite samo vijak(e). V primeru negotovosti, se po nasvet obrnite na strokovnjaka.

Türkçe

Ekteki sabitleme malzemesi çoğu sert (A) ve içi boş duvar (B) için kullanılabilir. Masif ahşap yüzeylerde (C) dübelsiz vida / vida kullanın. Belirsizlik durumunda daima profesyonel tavsiye alın.

عربي

يمكن استخدام المسامير (المسامير) والحشوة (الحشوات) البلاستيكية المرفقة في معظم الجدران الصلبة (A) والمجوفة (B). أما مع الخشب الصلب (C)، استخدم المسامير (المسامير) بدون حشوات. في حالة عدم المعرفة، يرجى طلب مساعدة فني مختص.

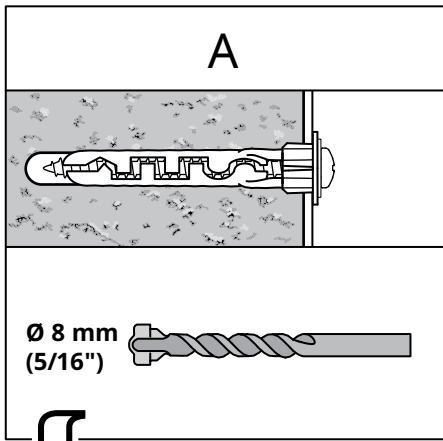

32

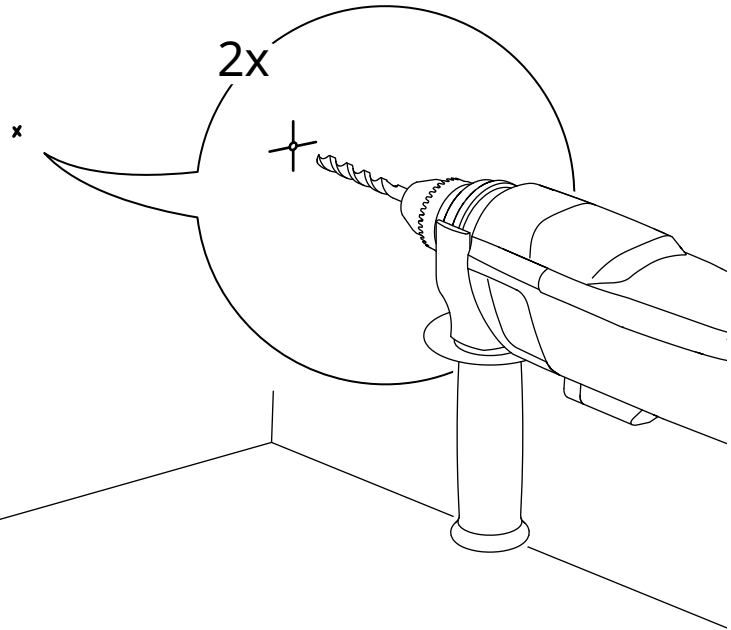

33

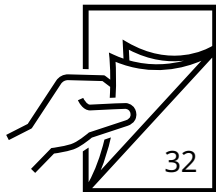
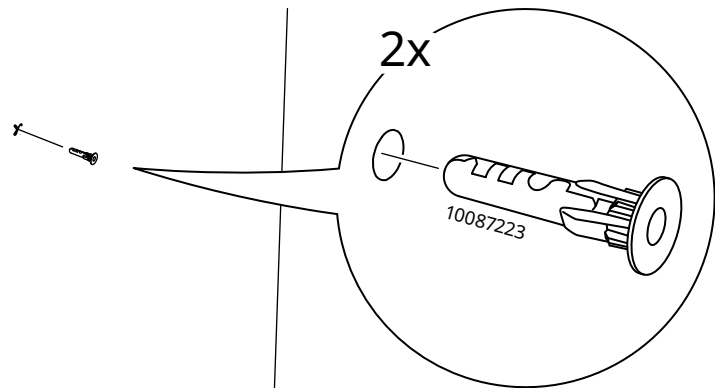

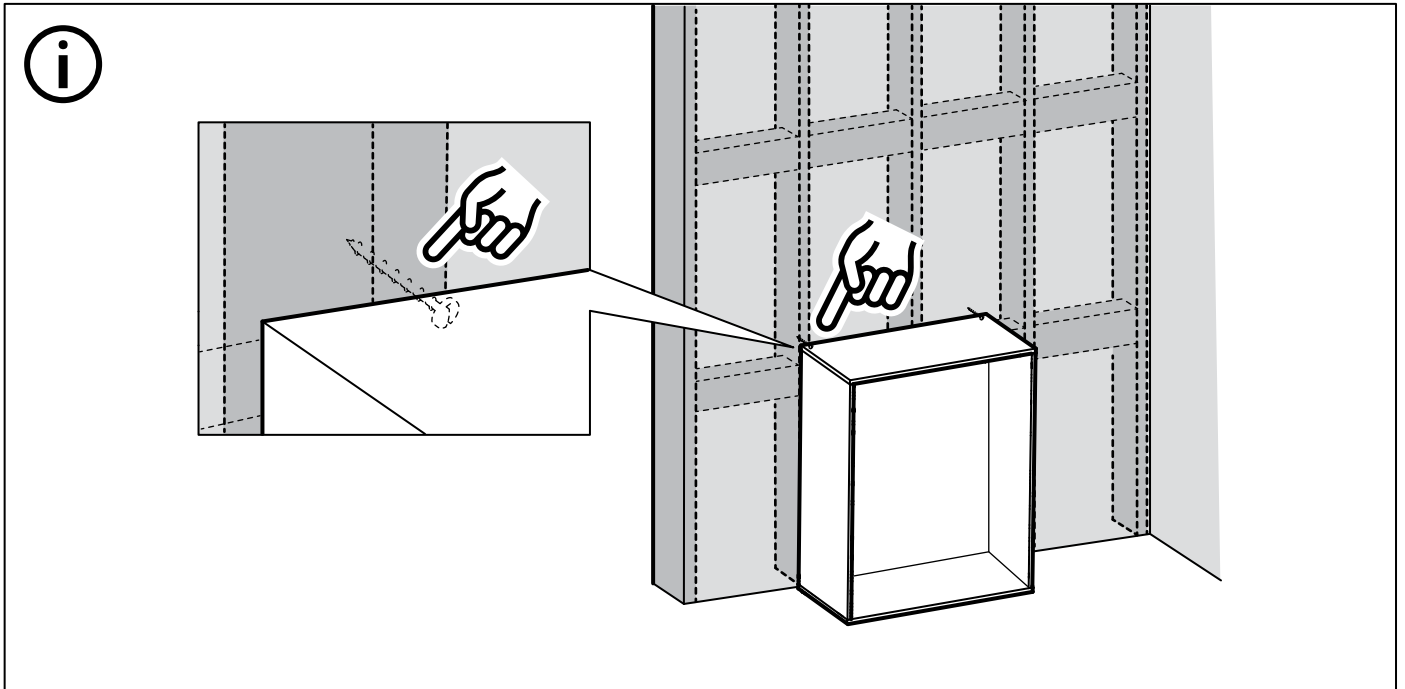
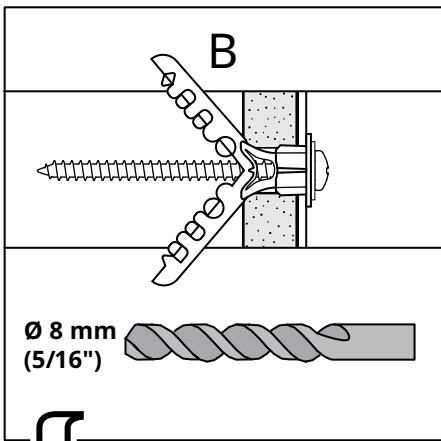

32

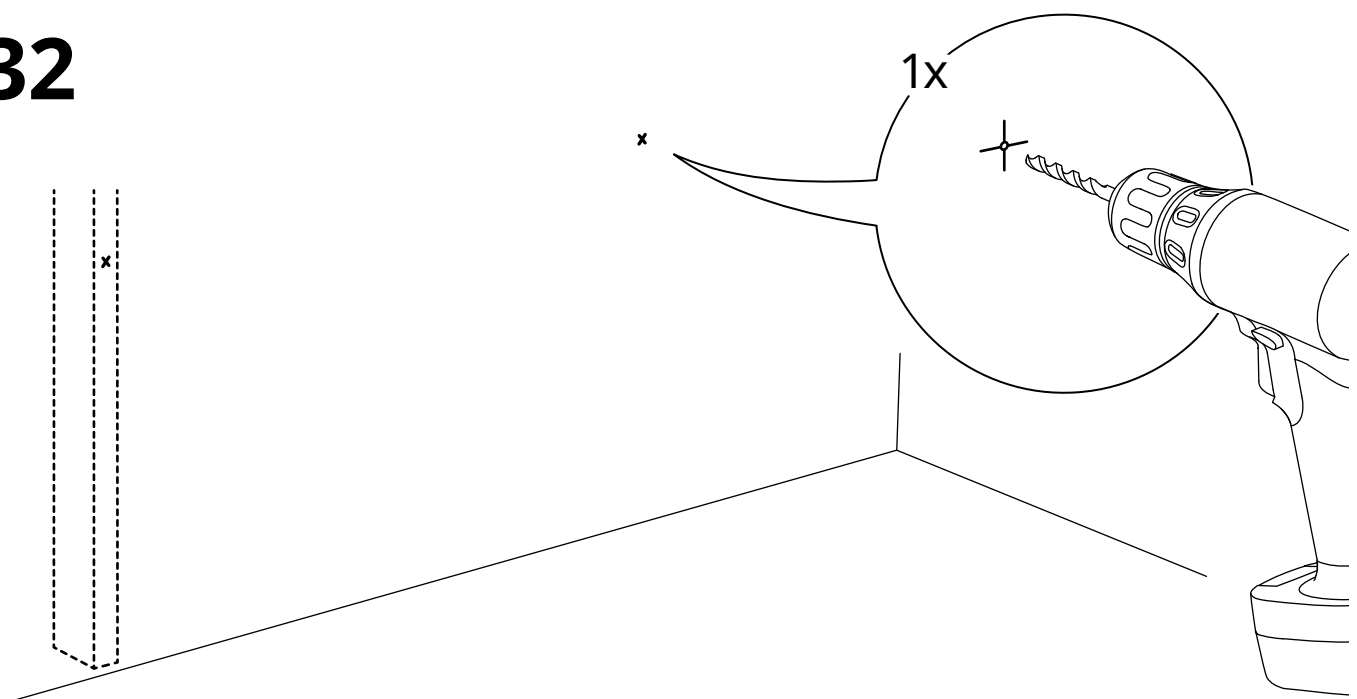

33

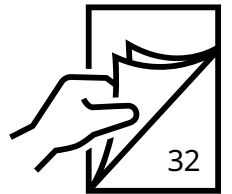
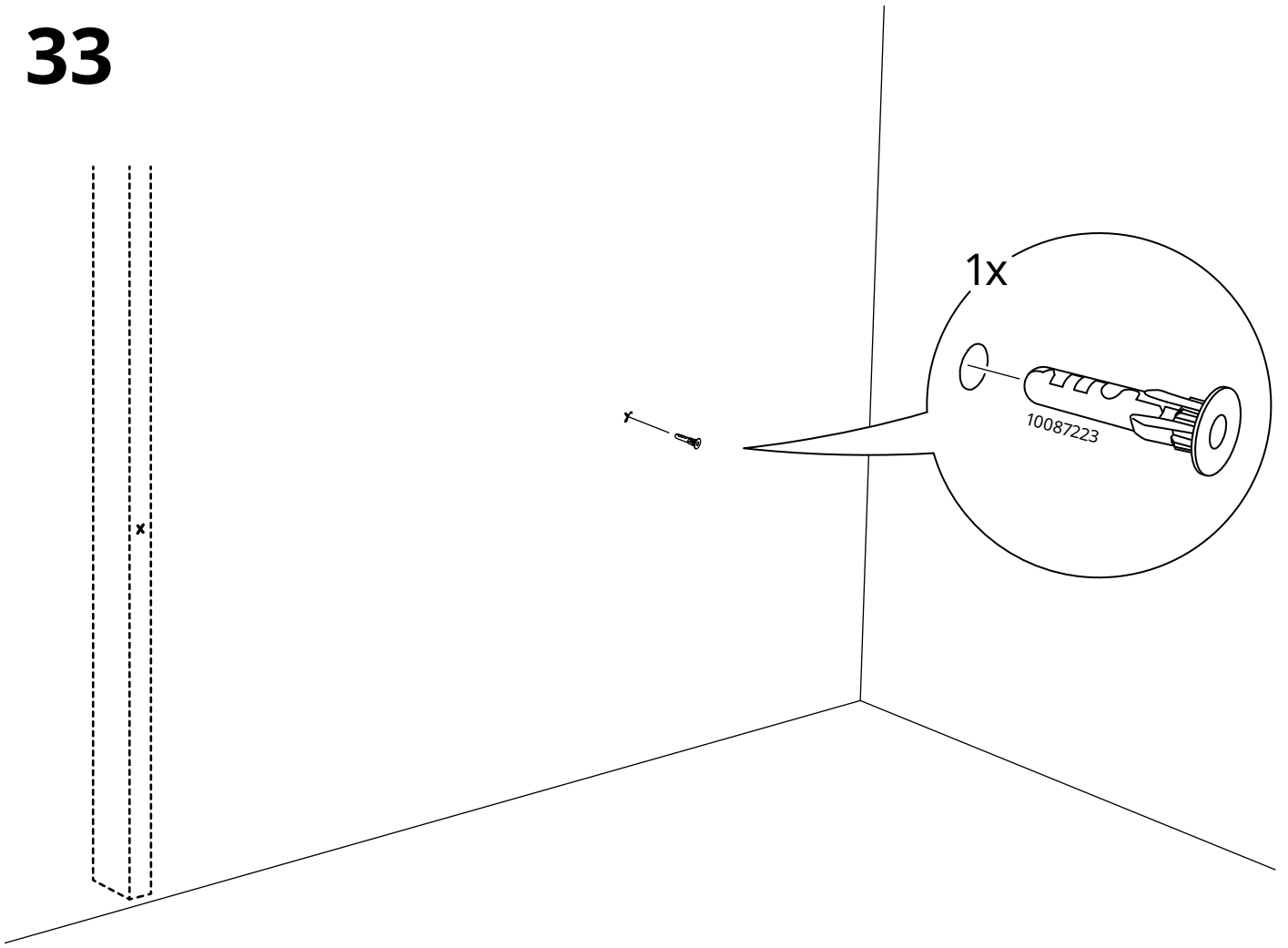

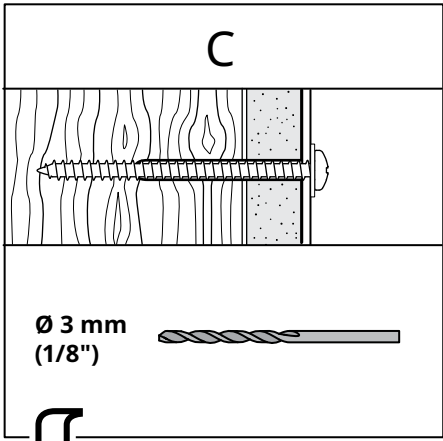

32

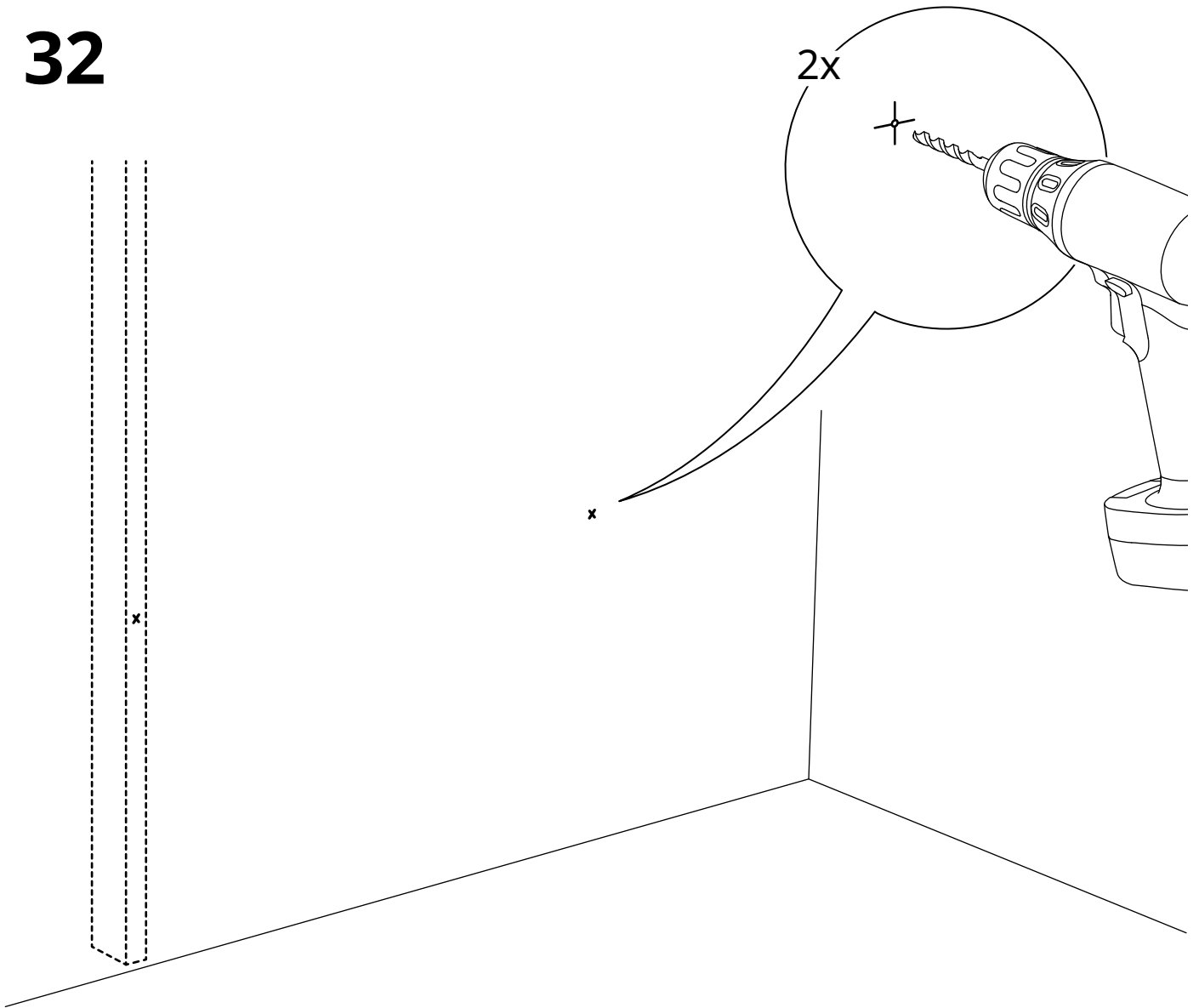

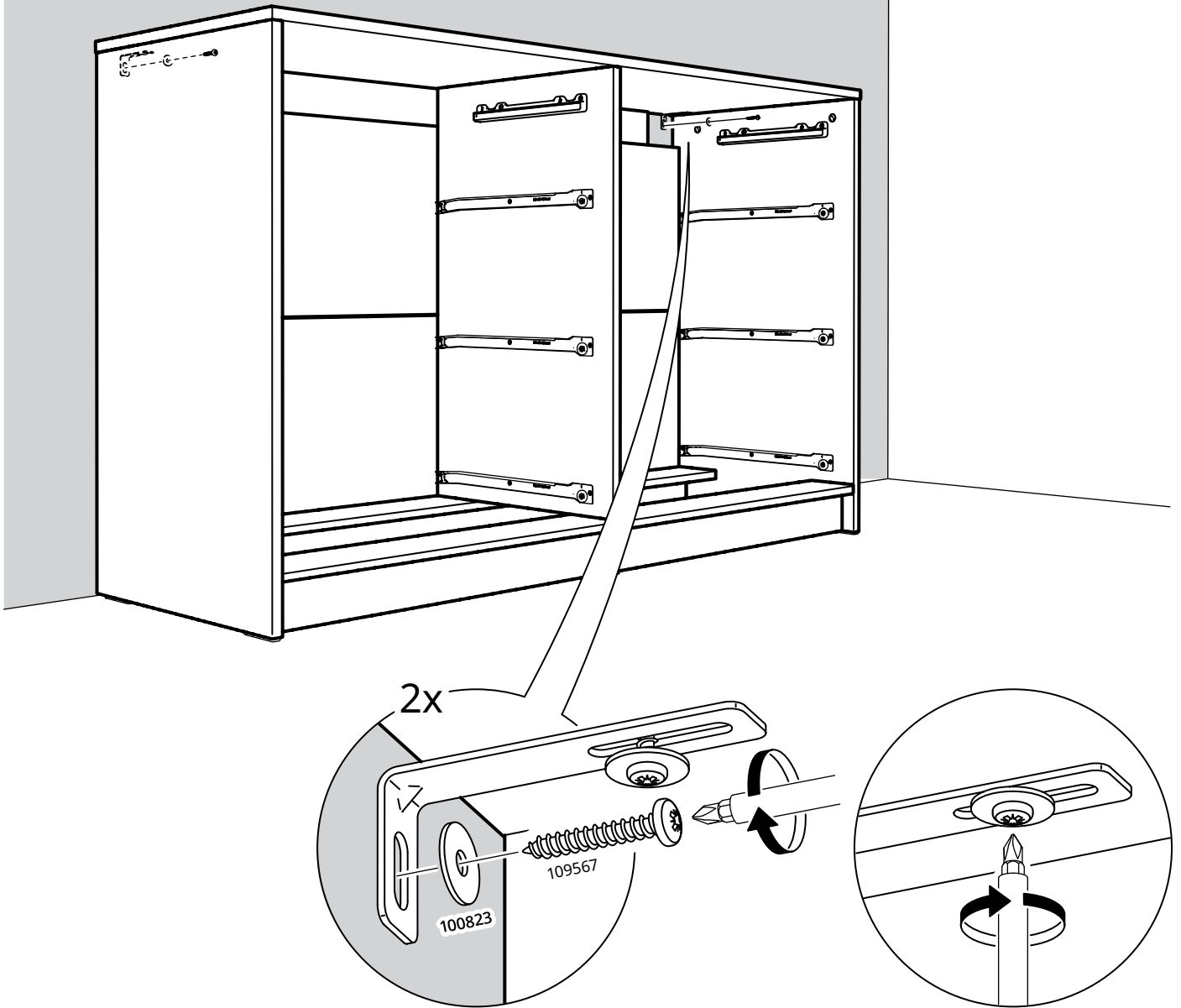

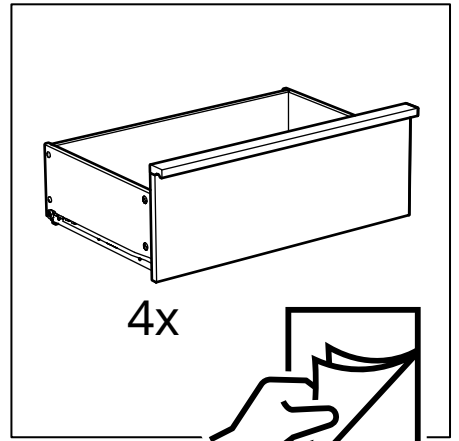
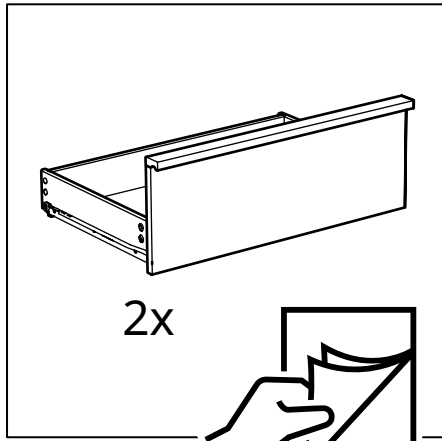
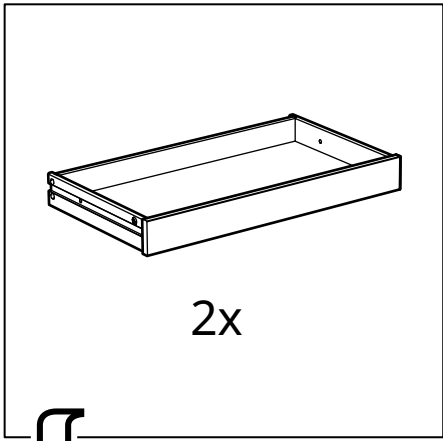

35

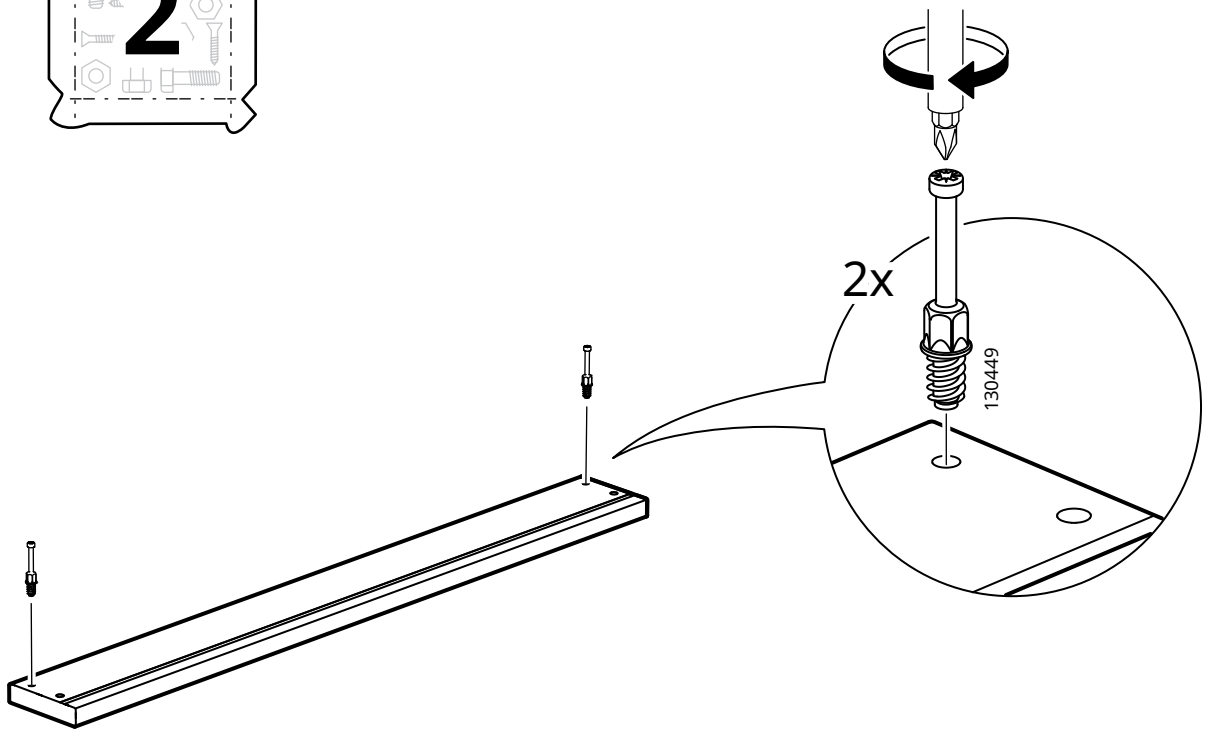

36

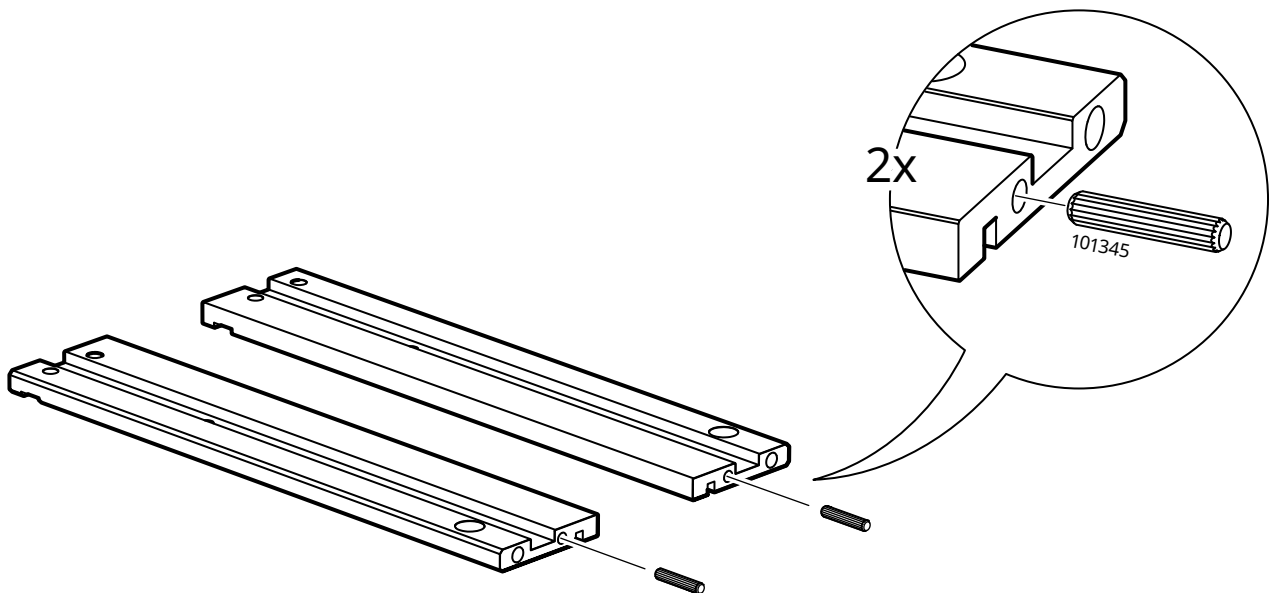

37

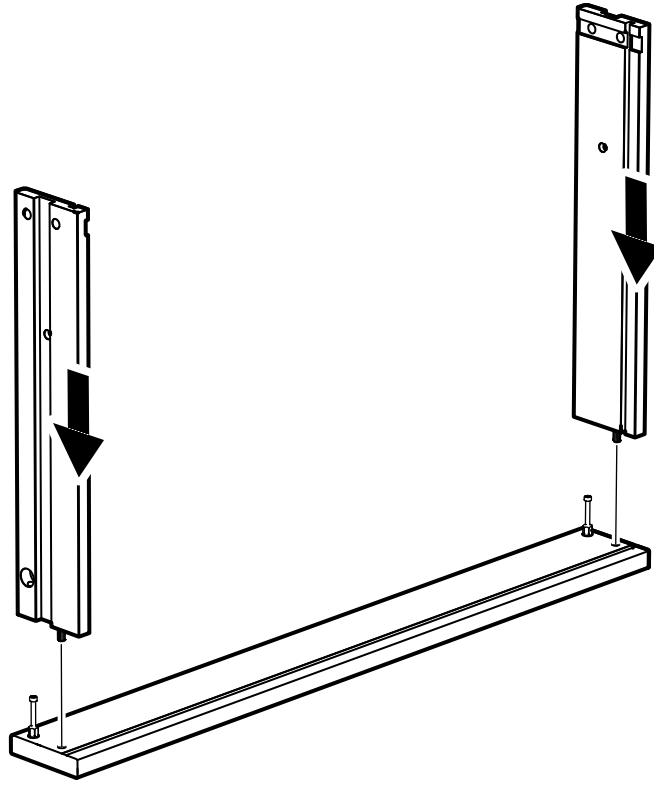

38

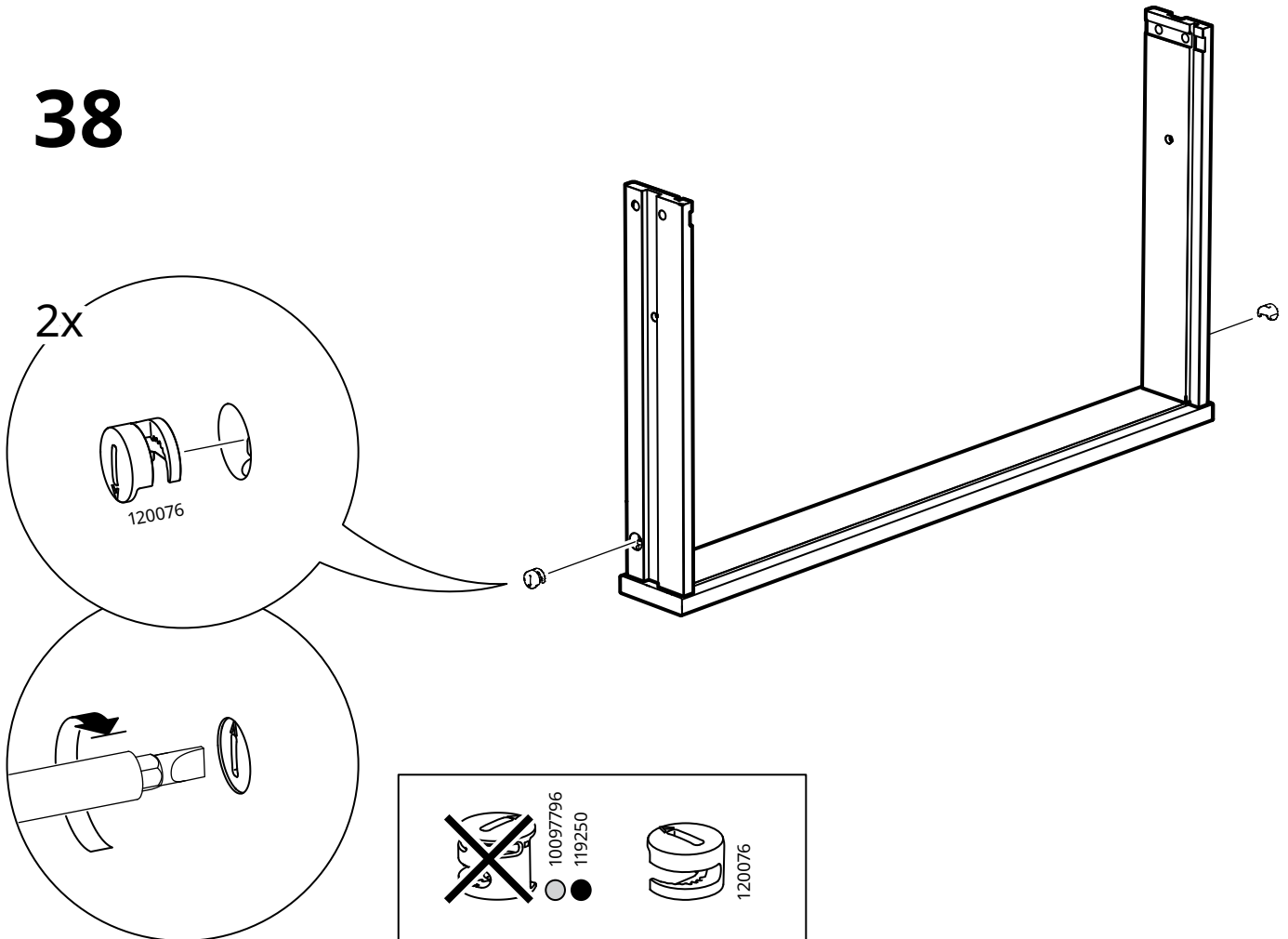

39

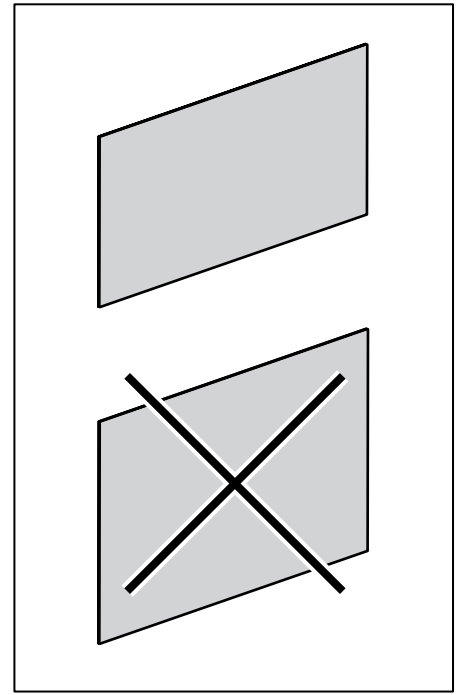
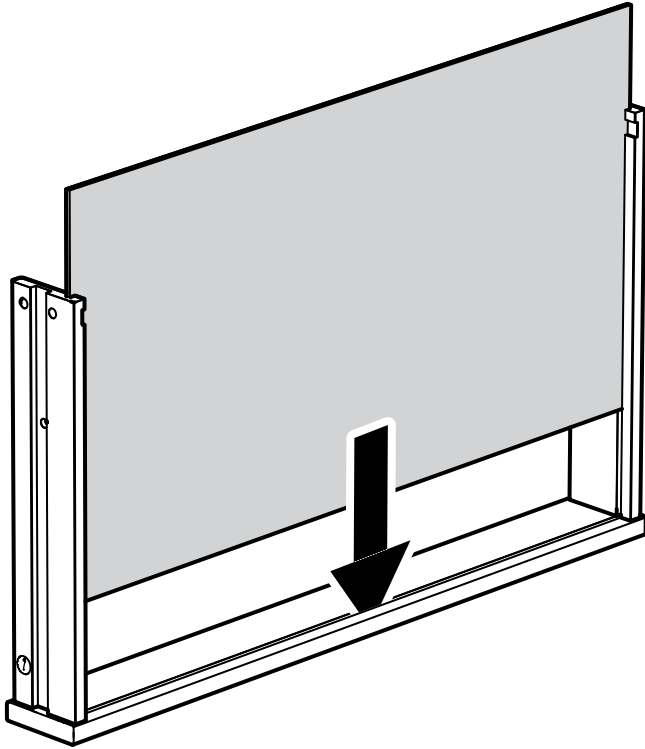

40

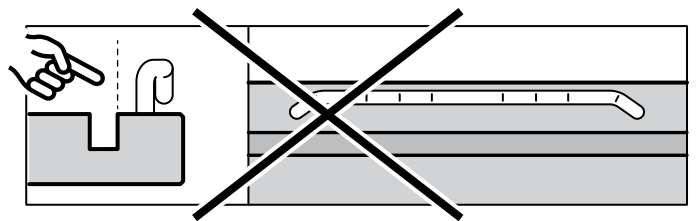
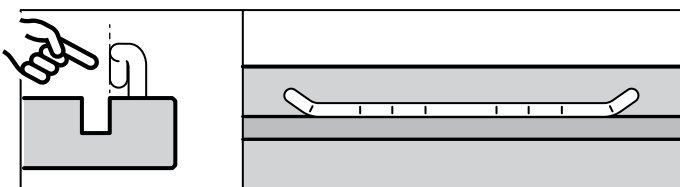
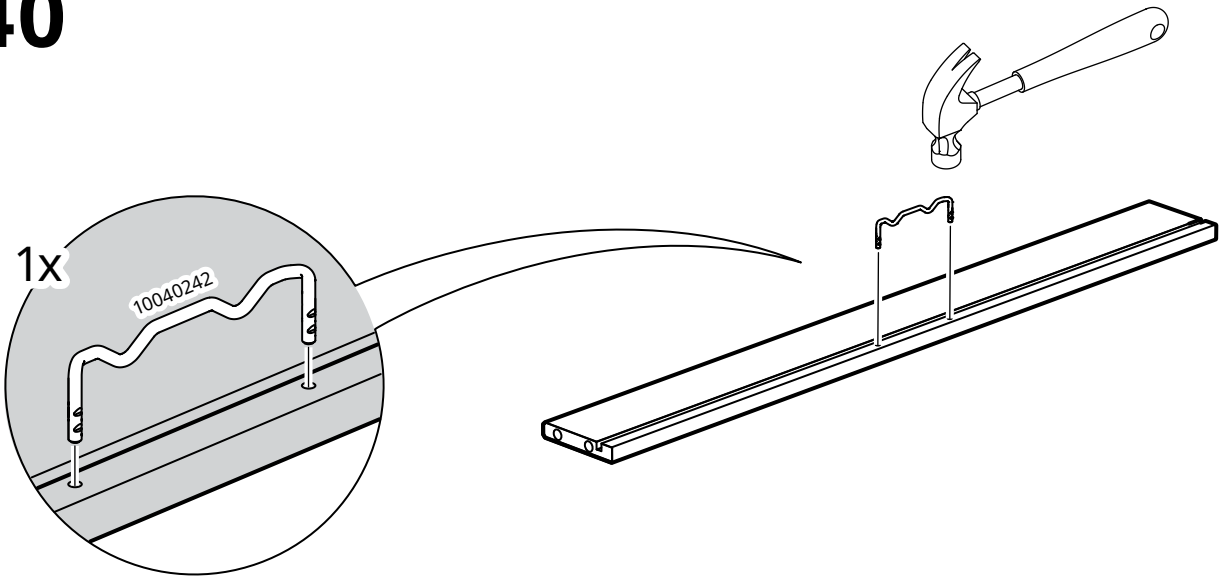

41

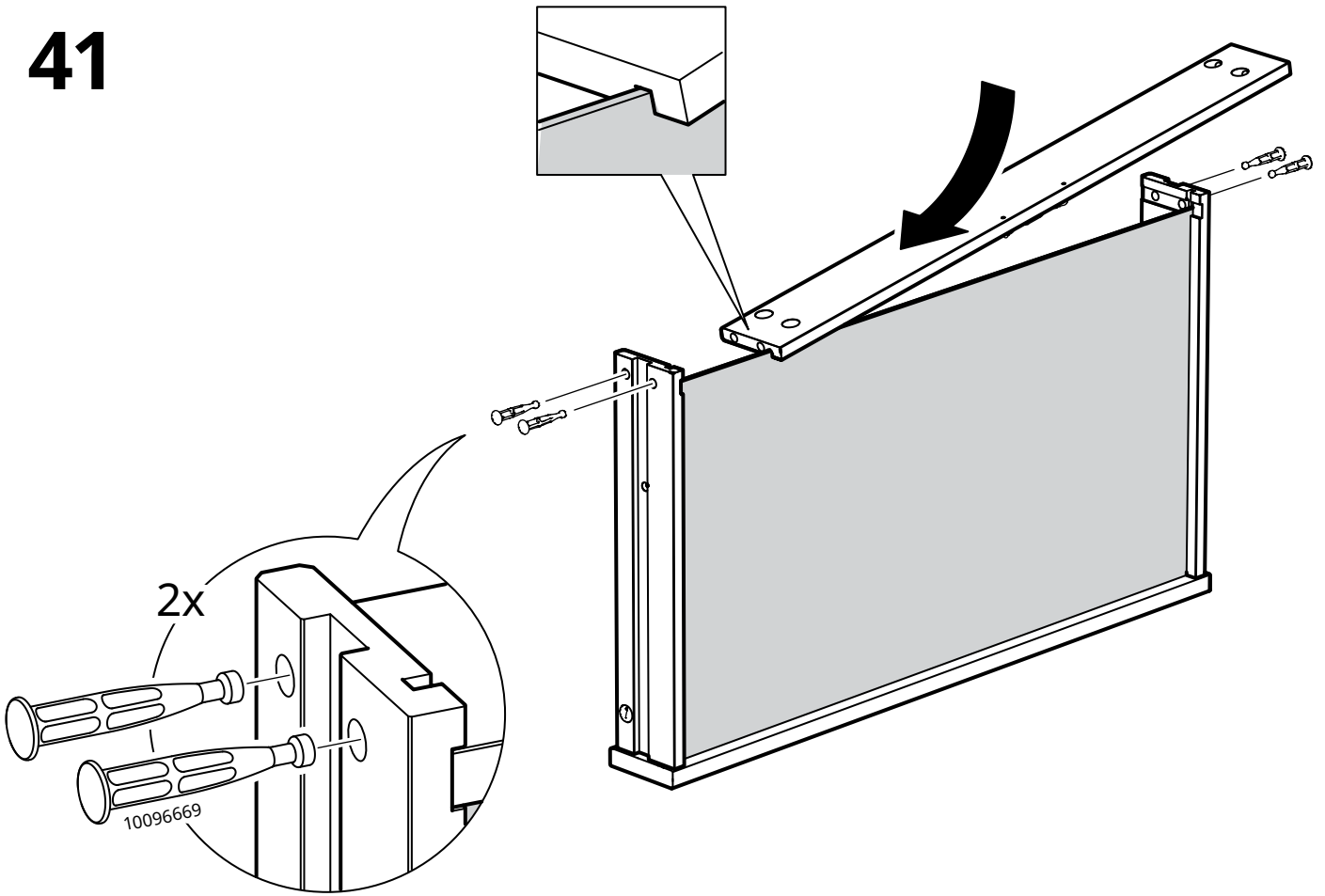

42

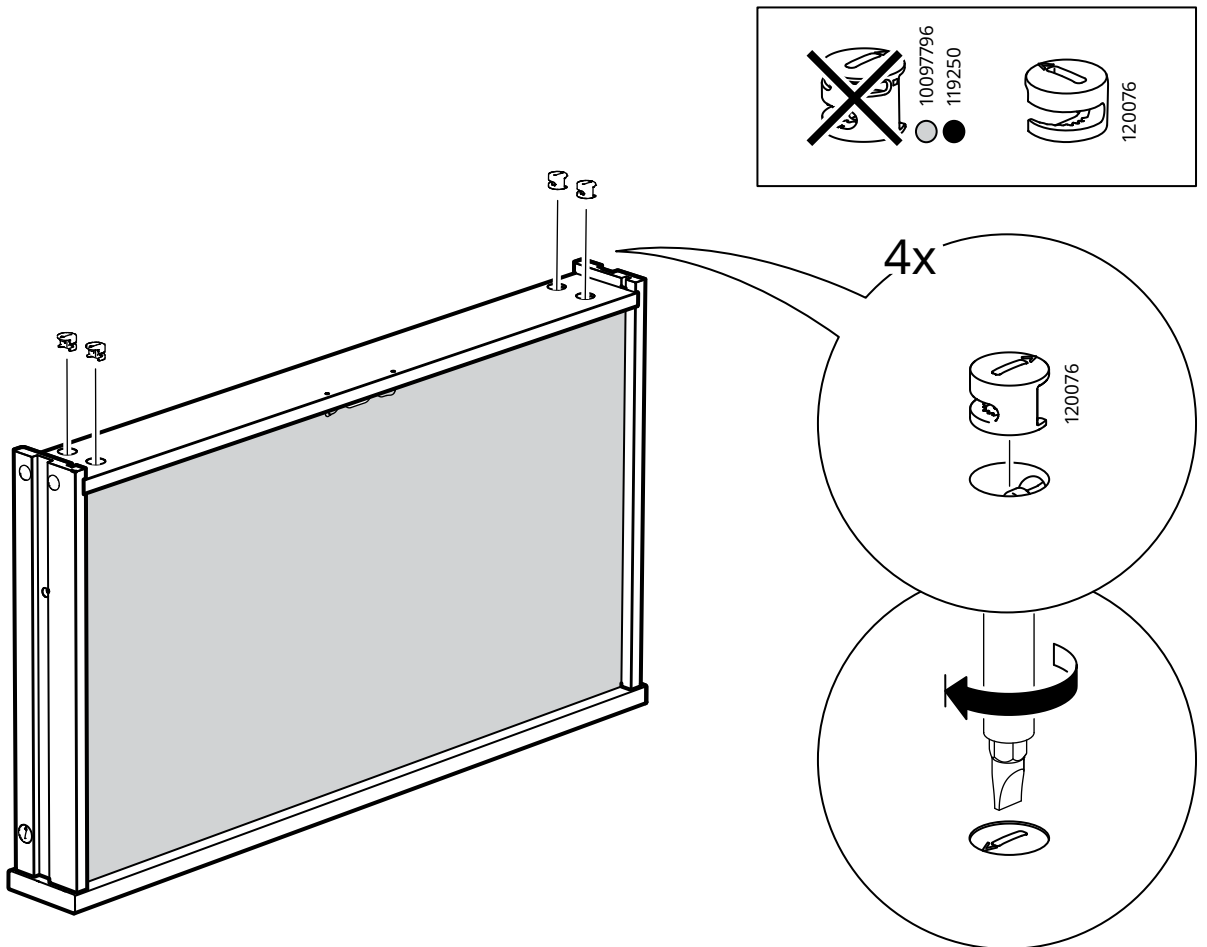

43



Max. 18 cm
(7")

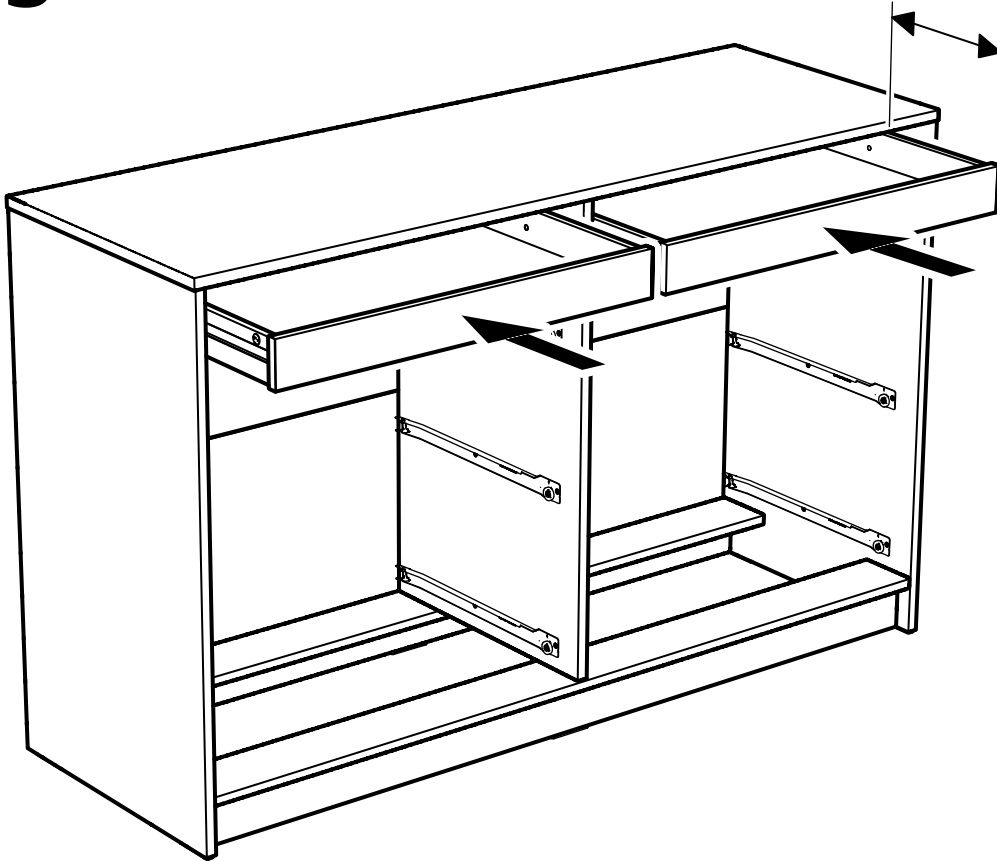

44

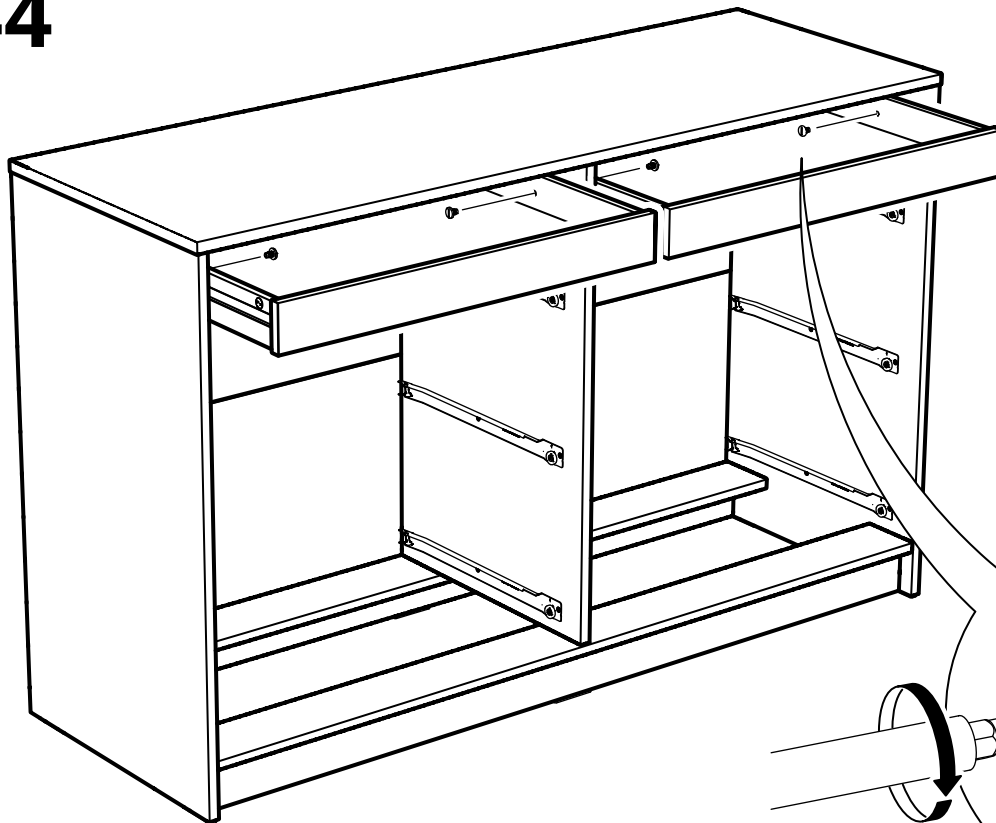

4x

102323

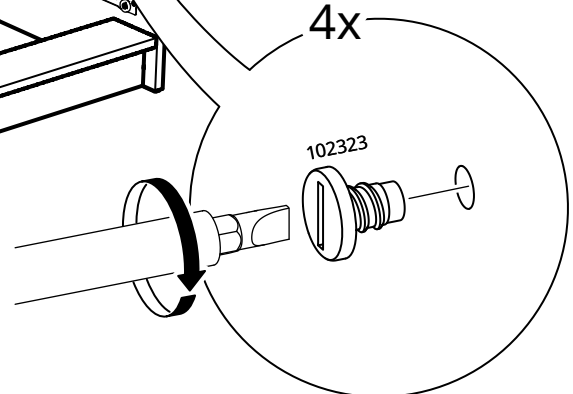

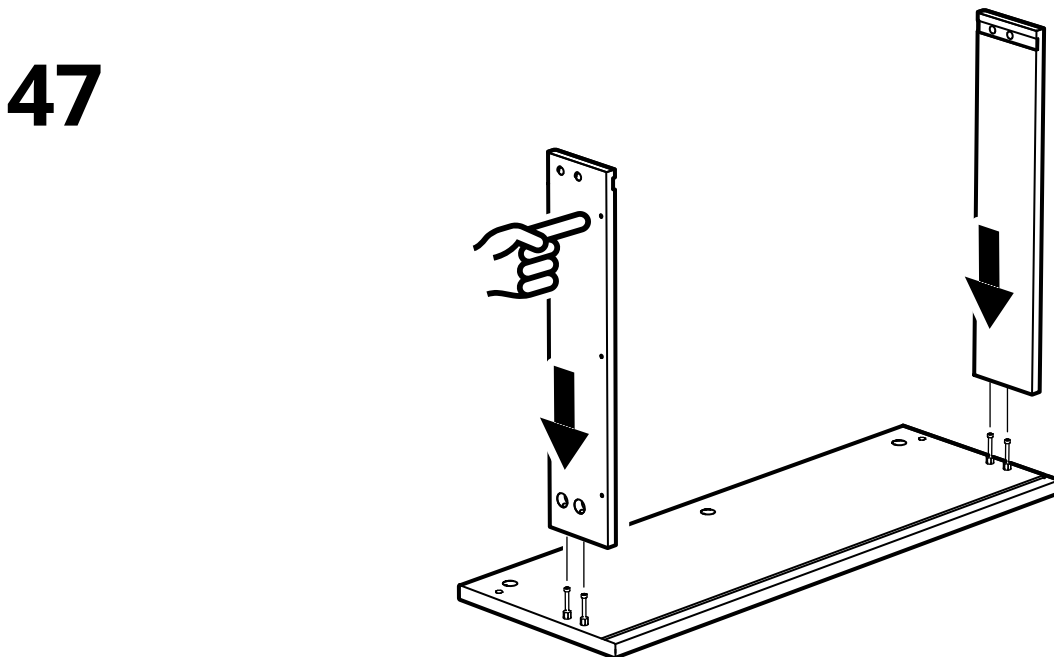
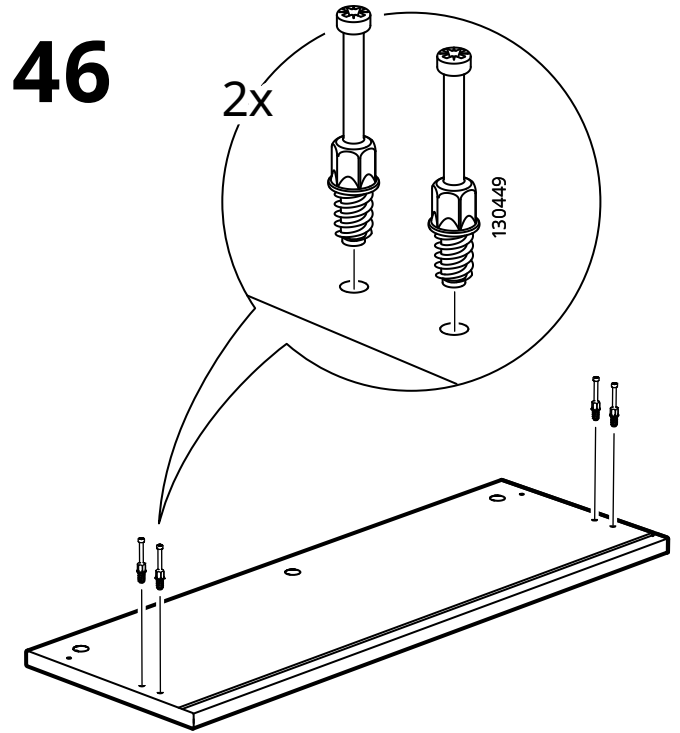
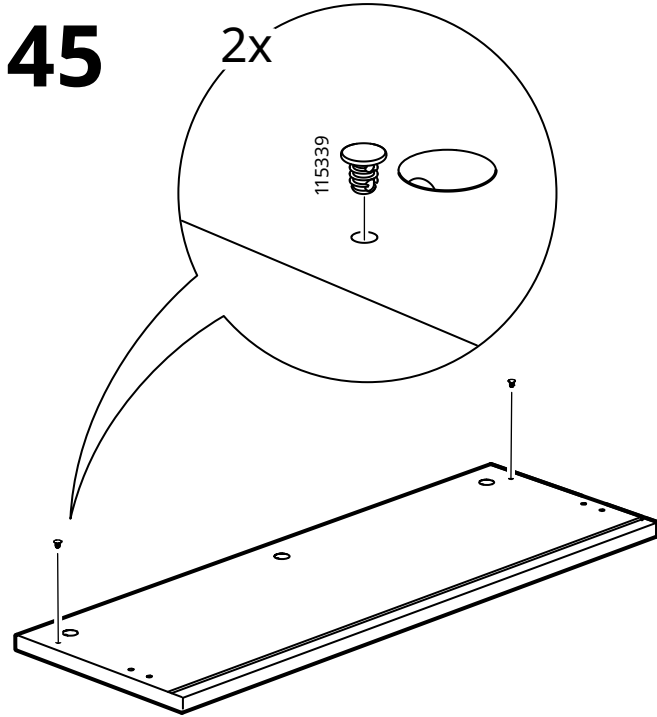
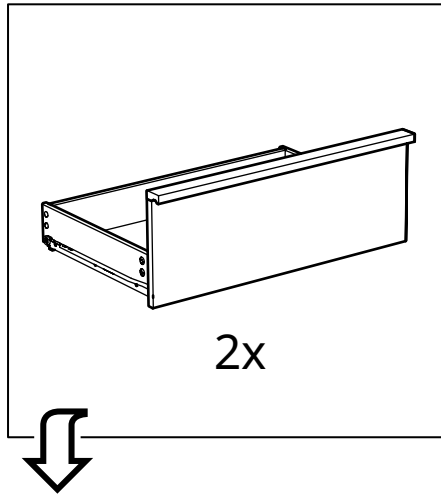

48

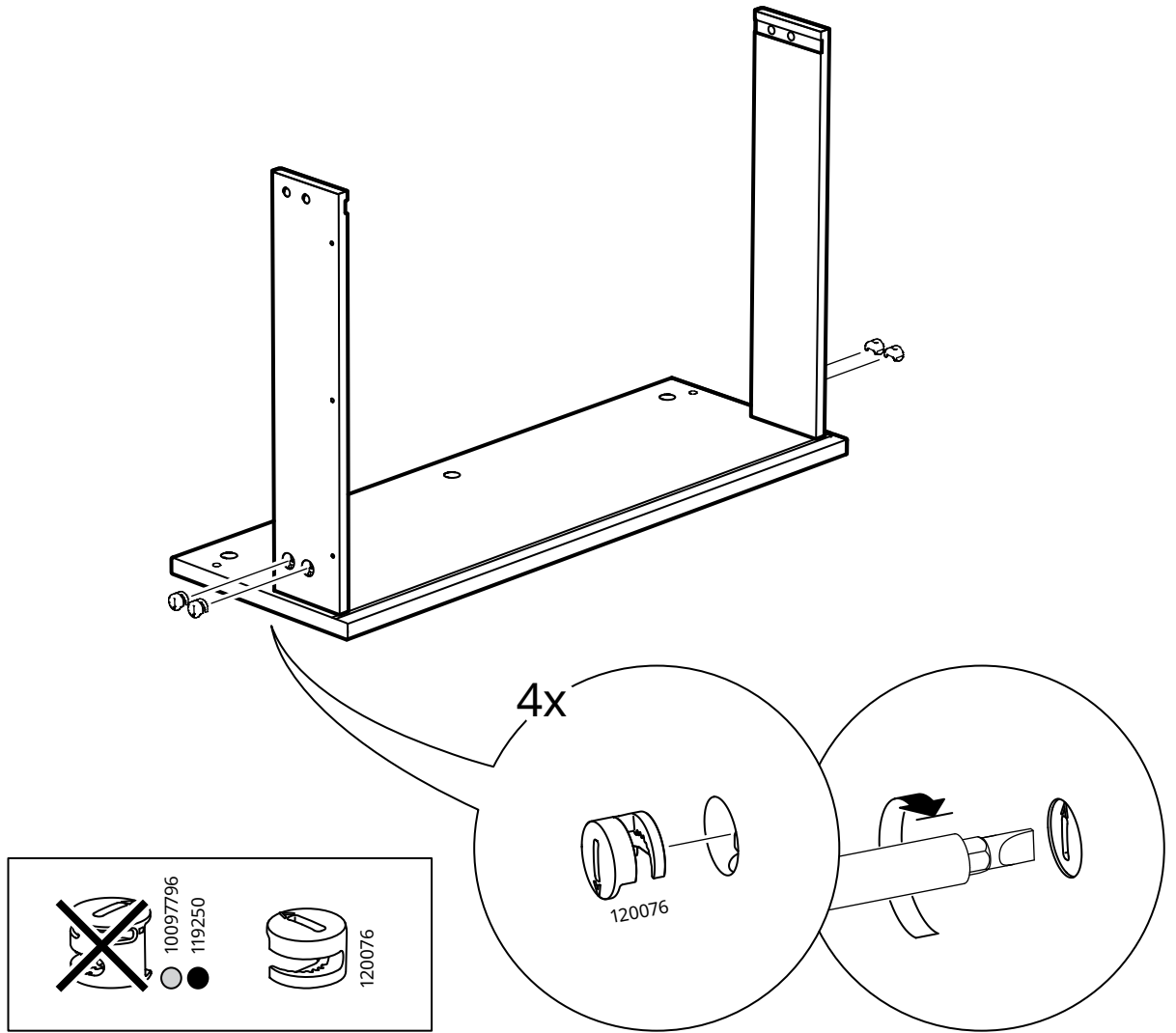

49

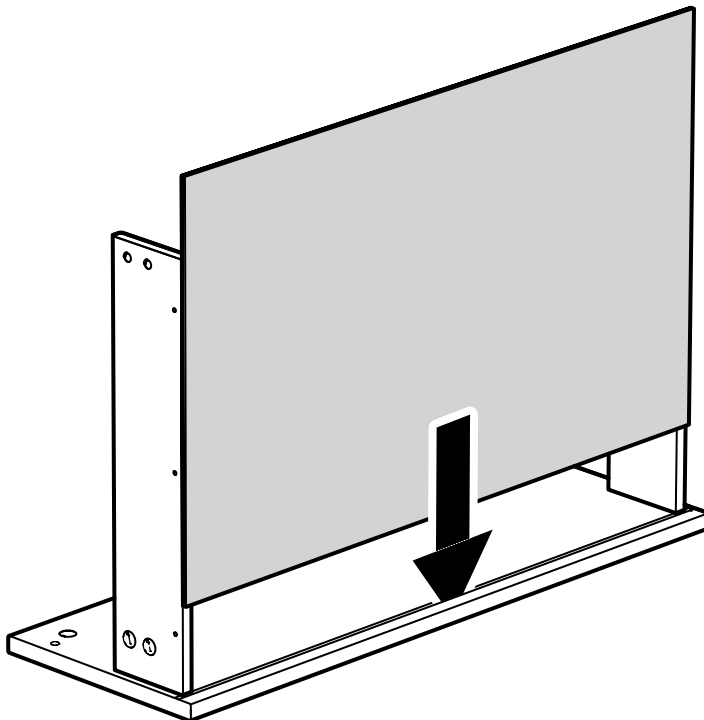

50

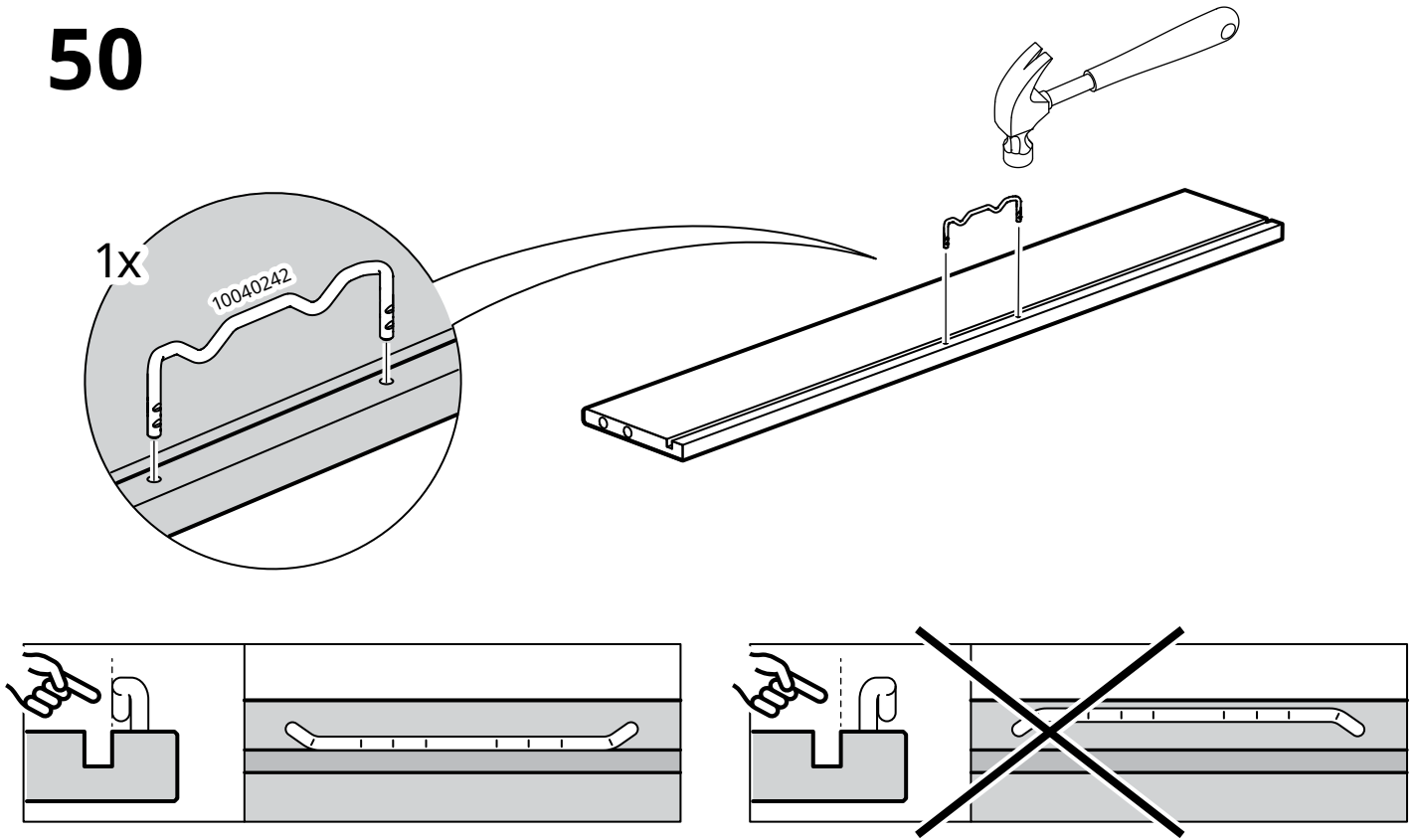

51

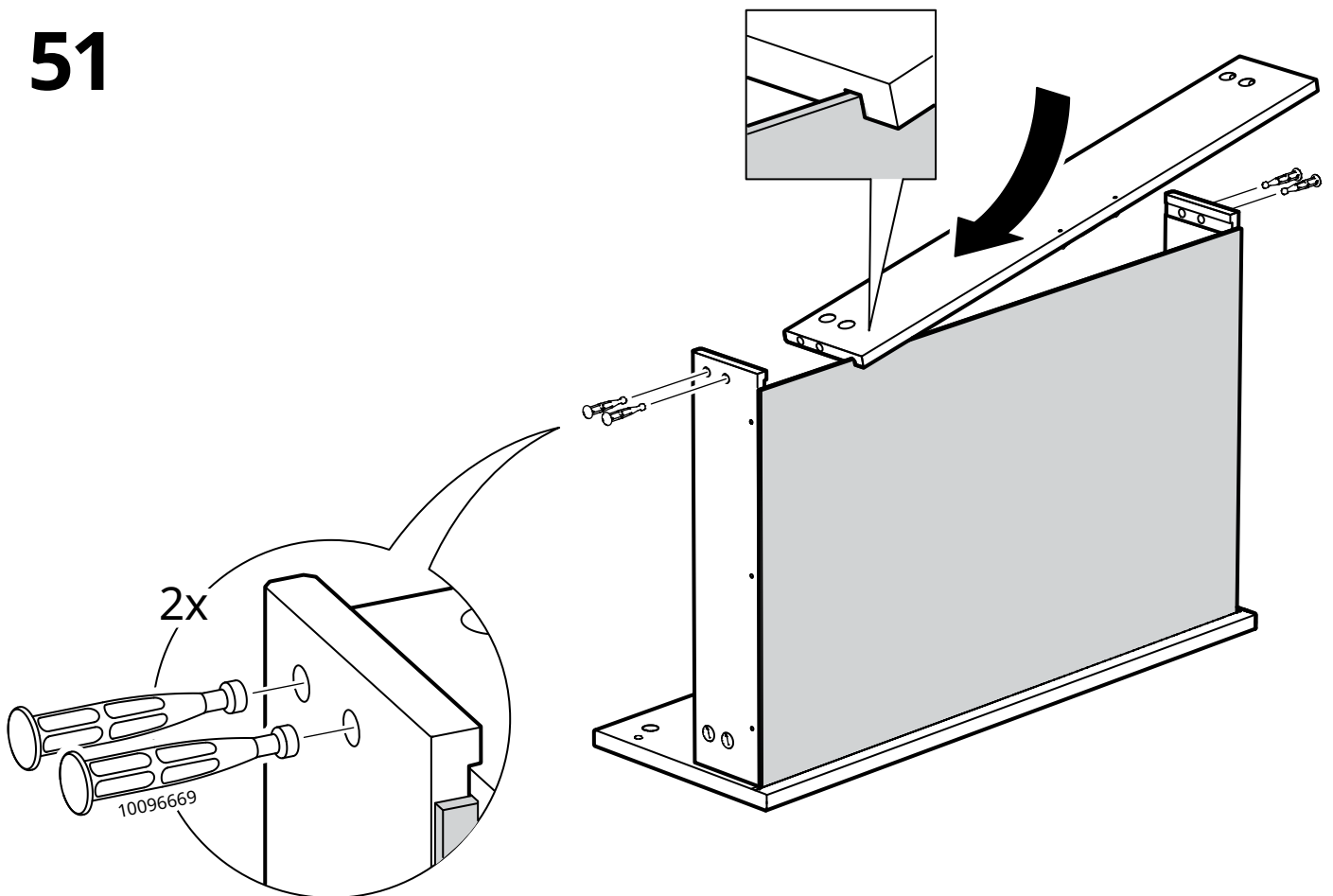

52

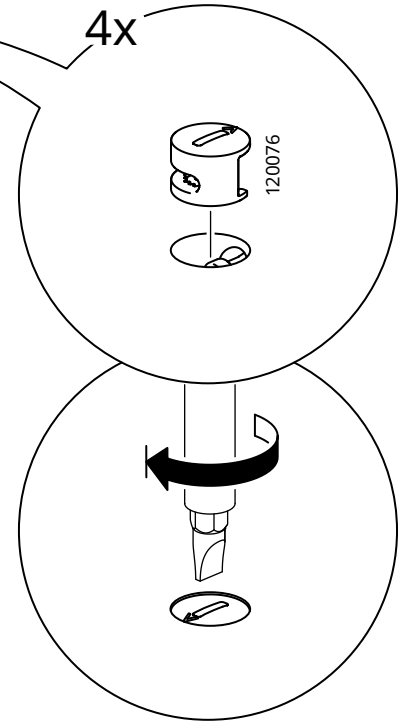
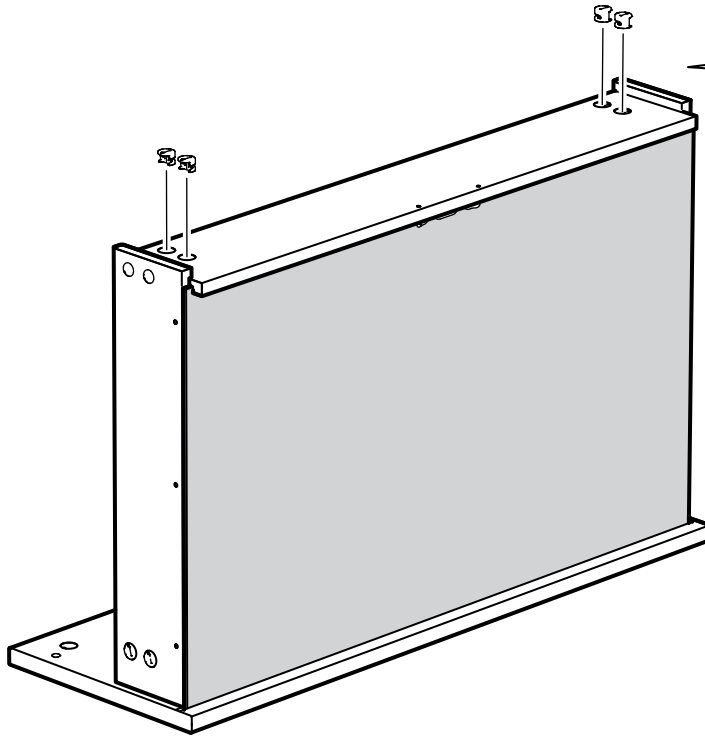
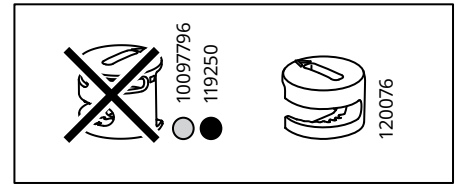

53

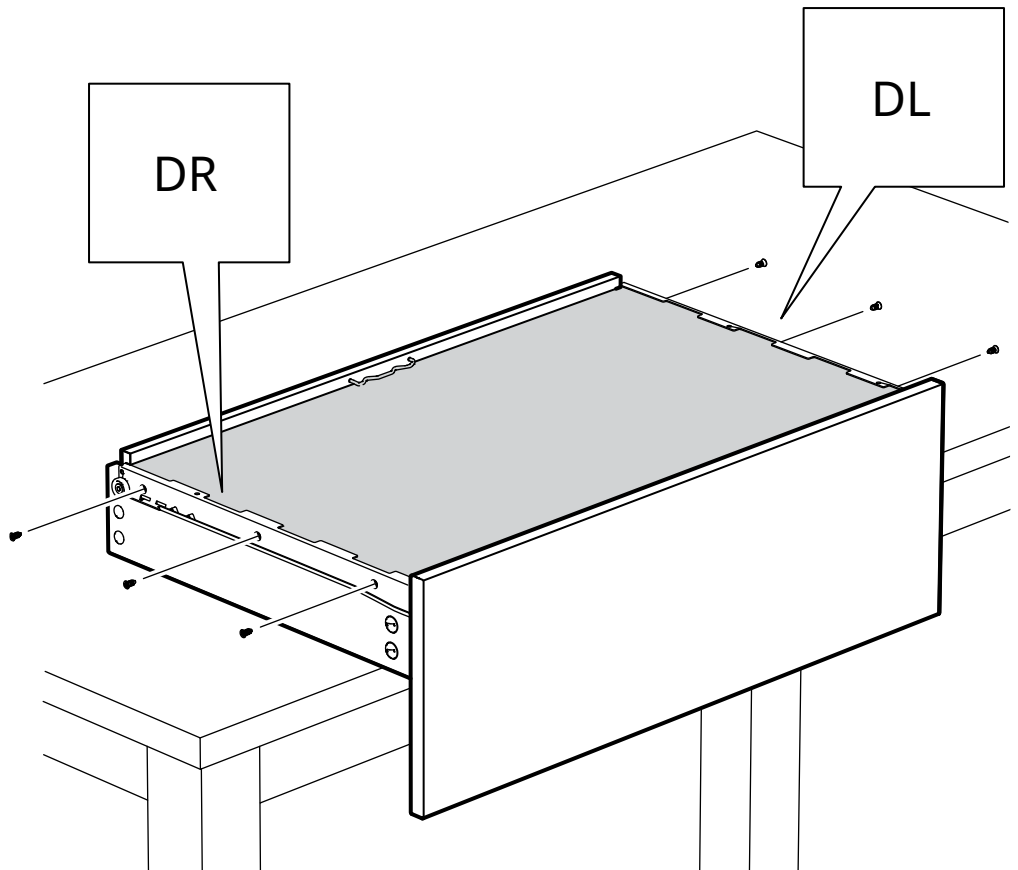
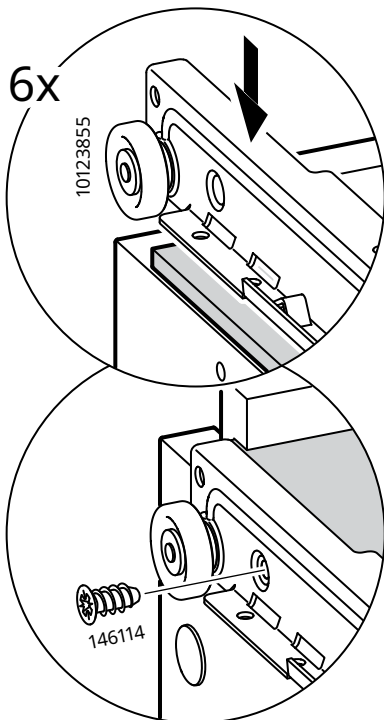

54

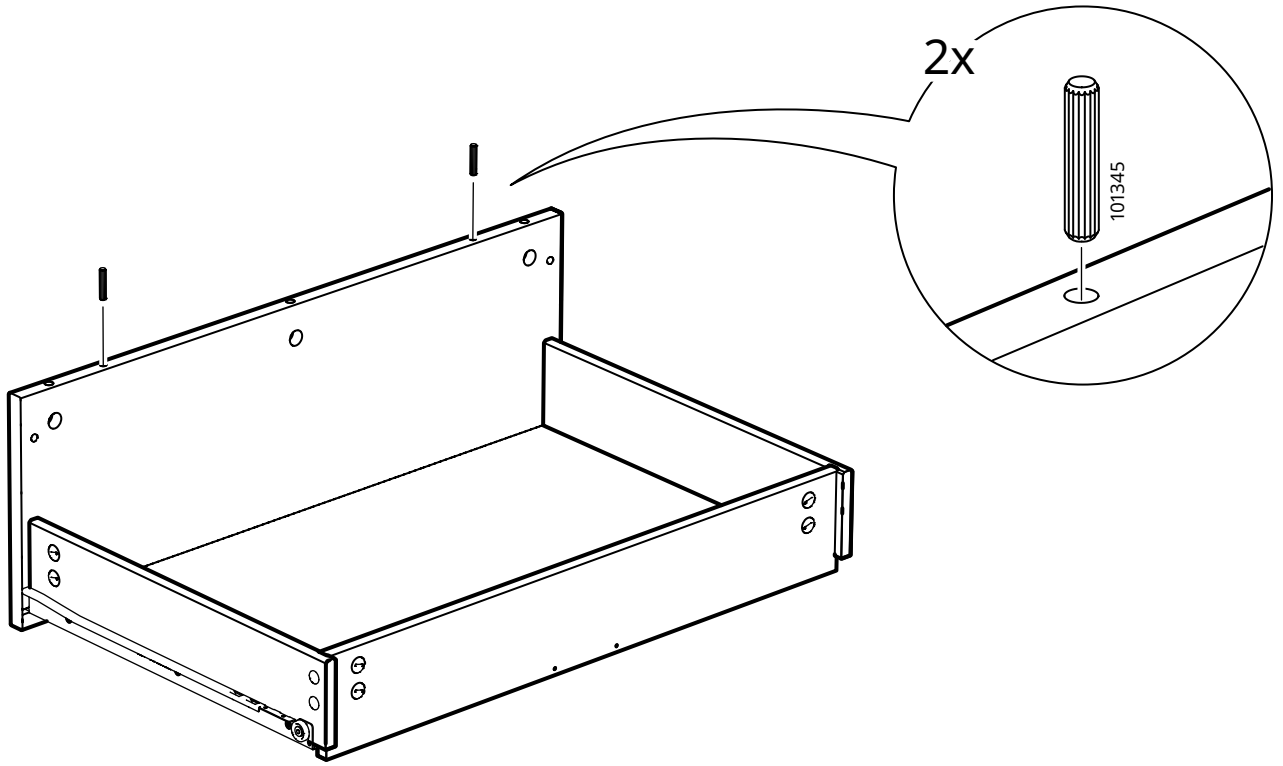

55

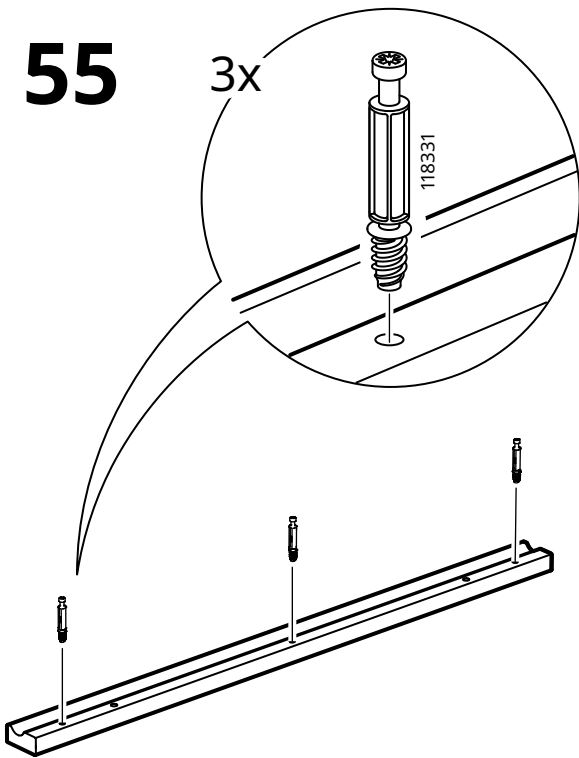

56

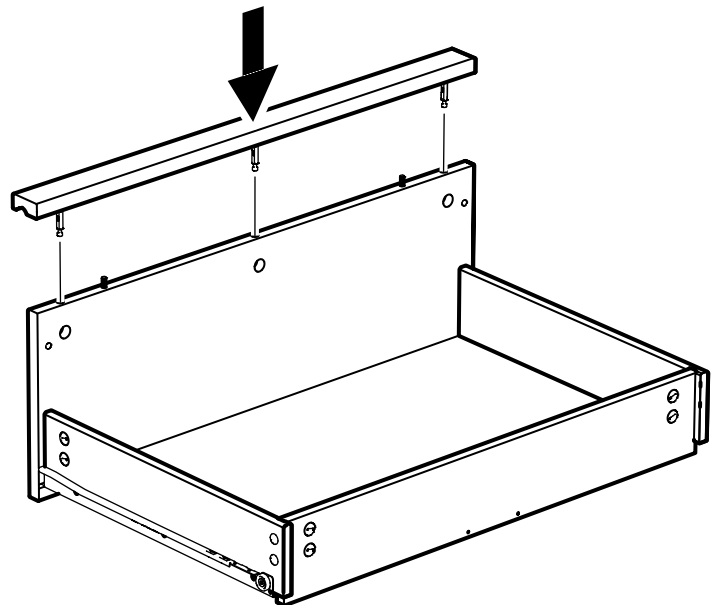

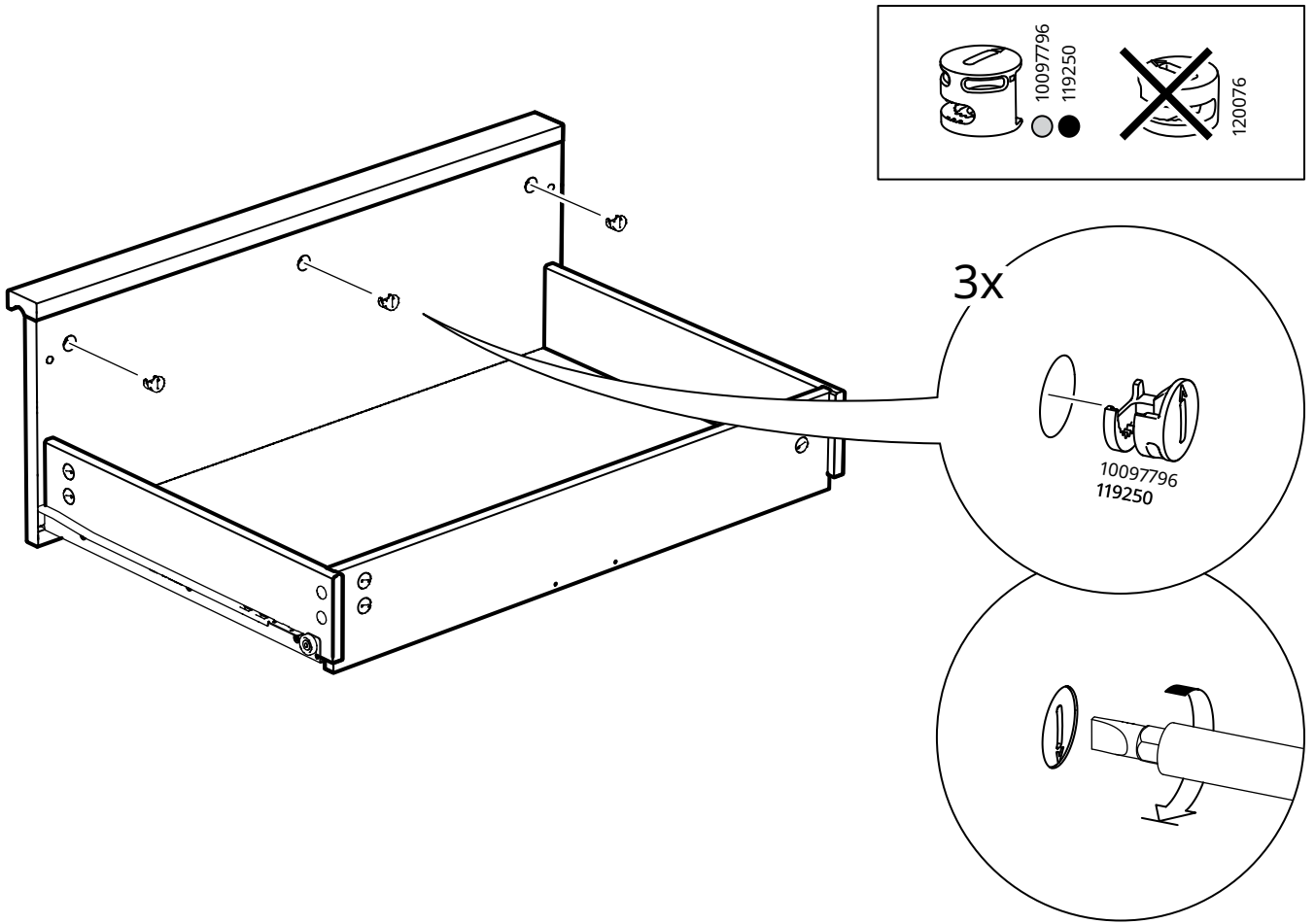

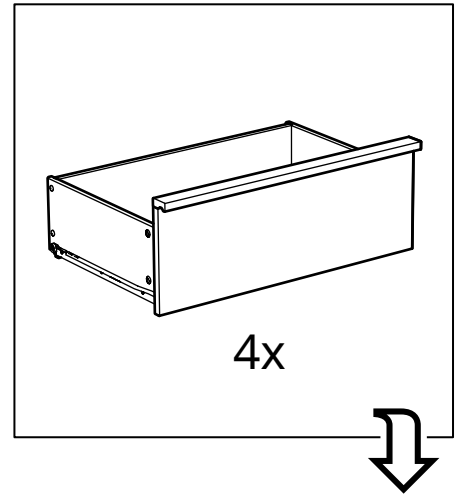

58

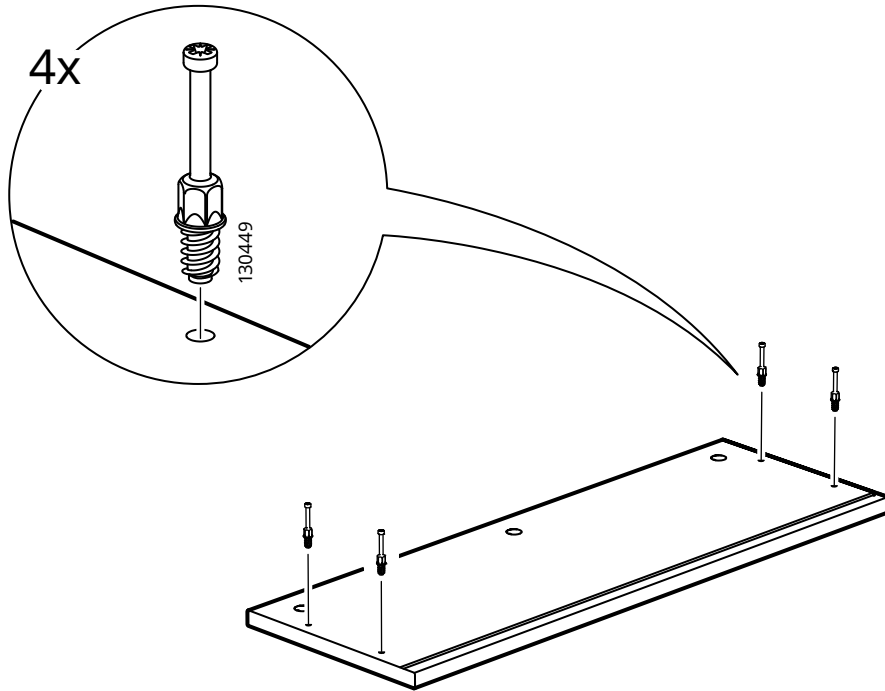

59

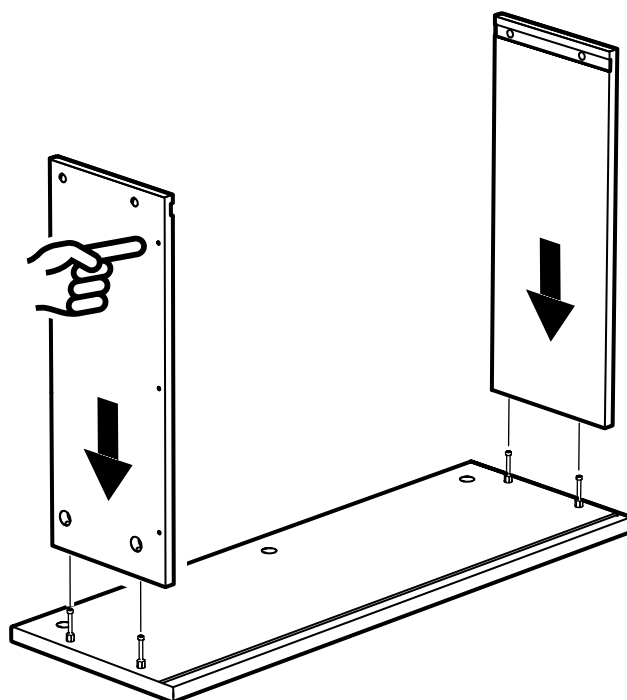

60

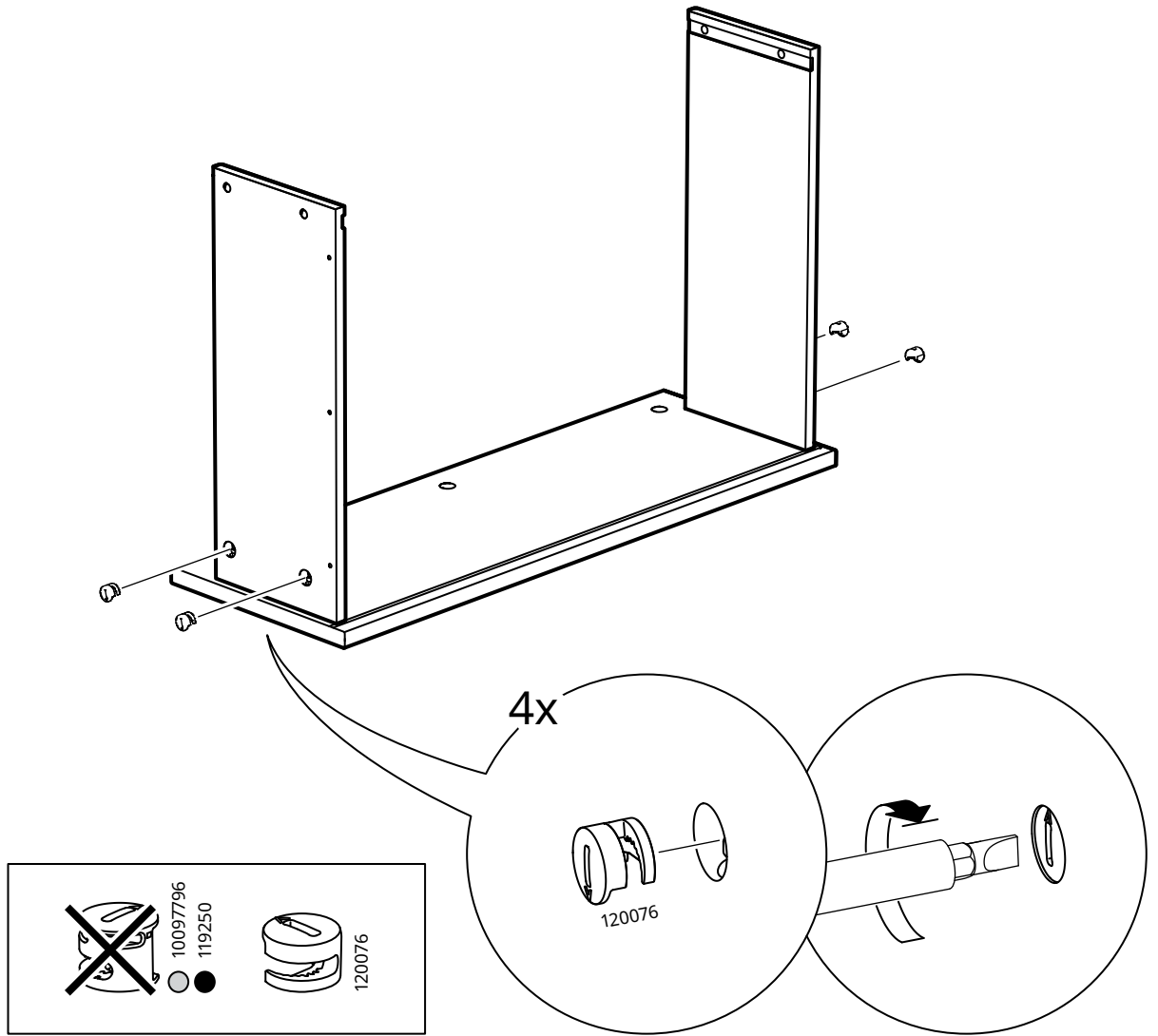

61

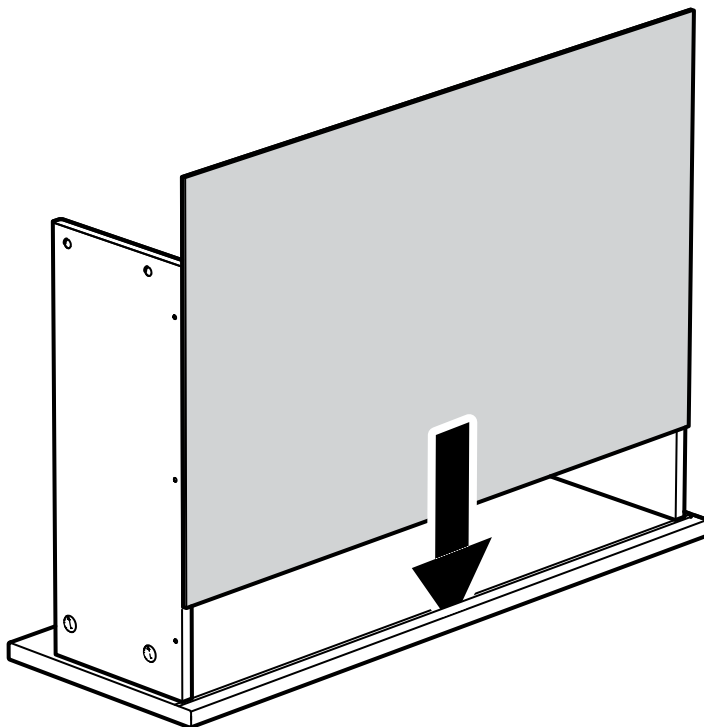

62

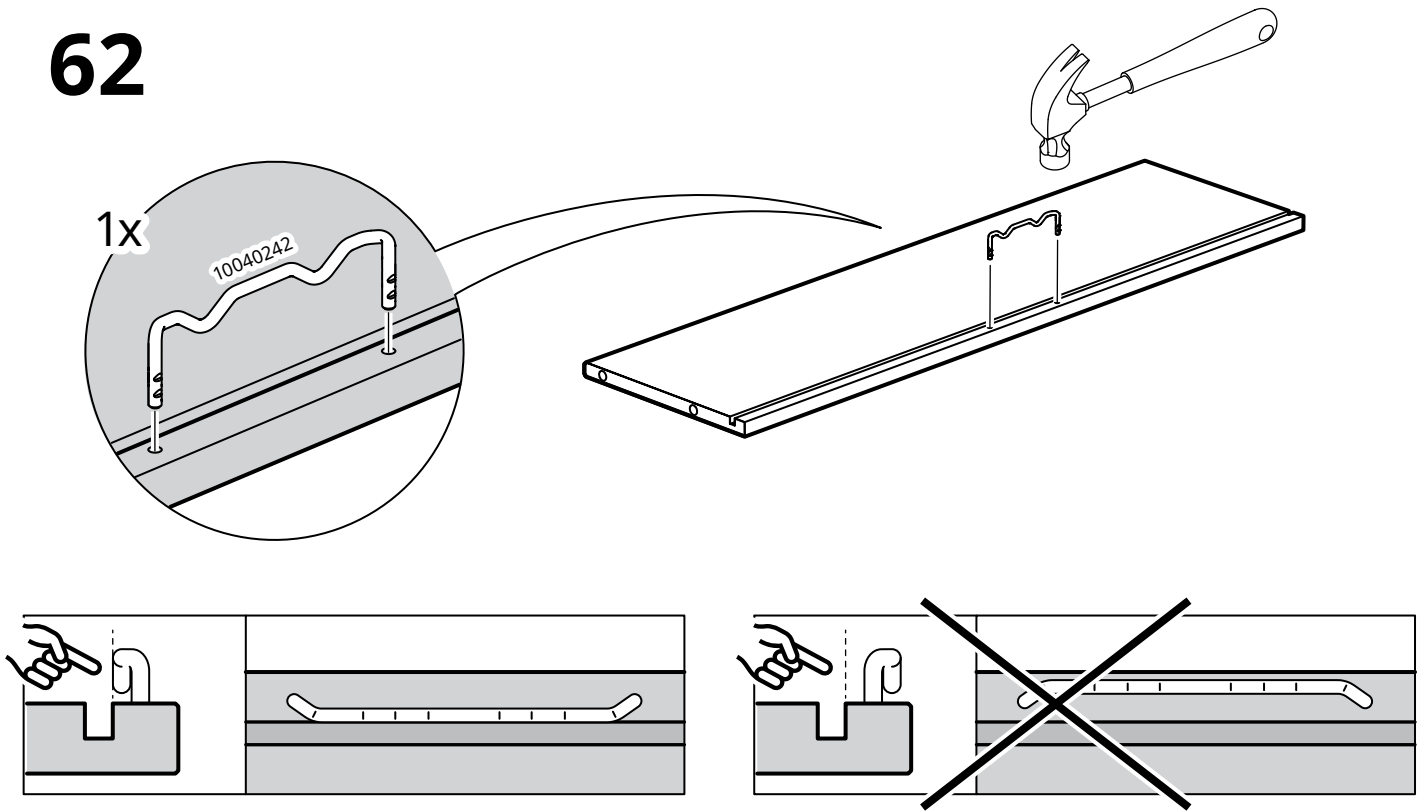

63

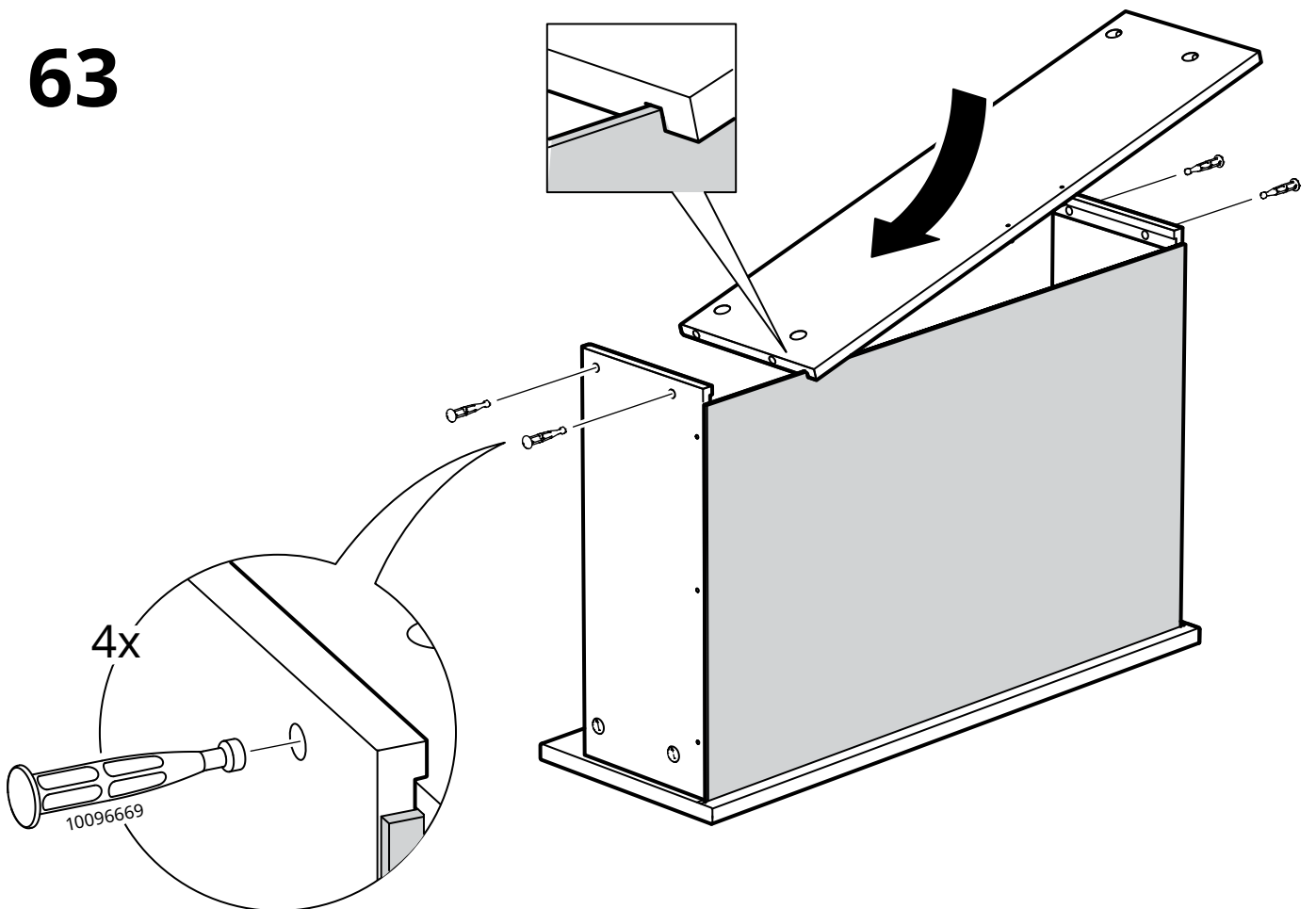

64

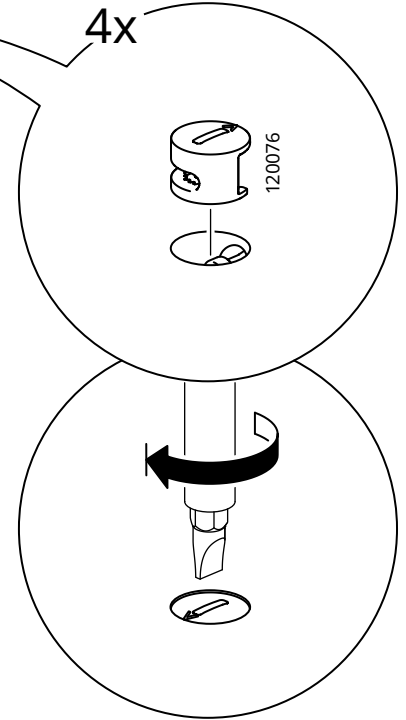
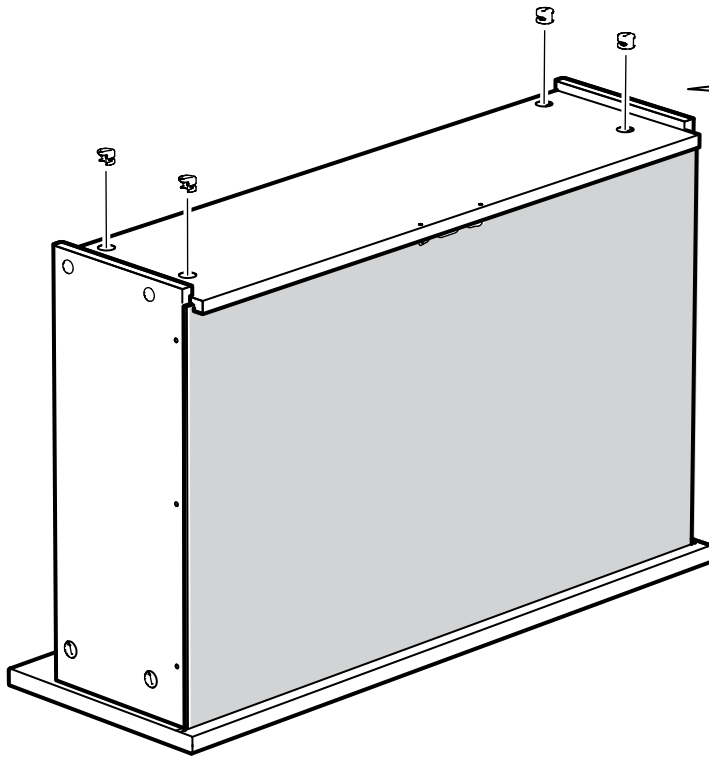
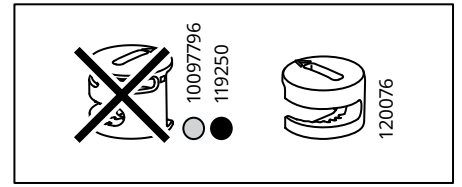

65

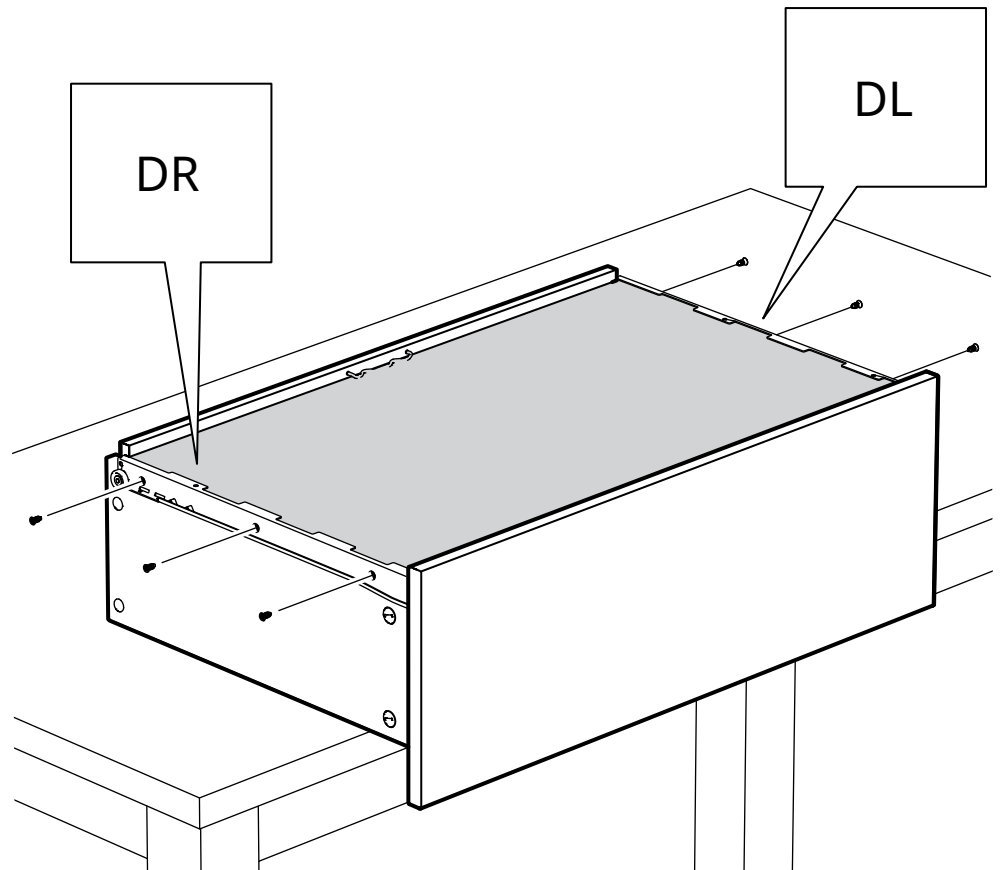
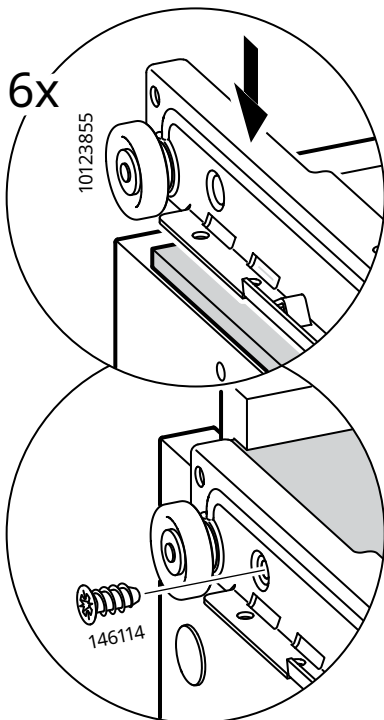

66

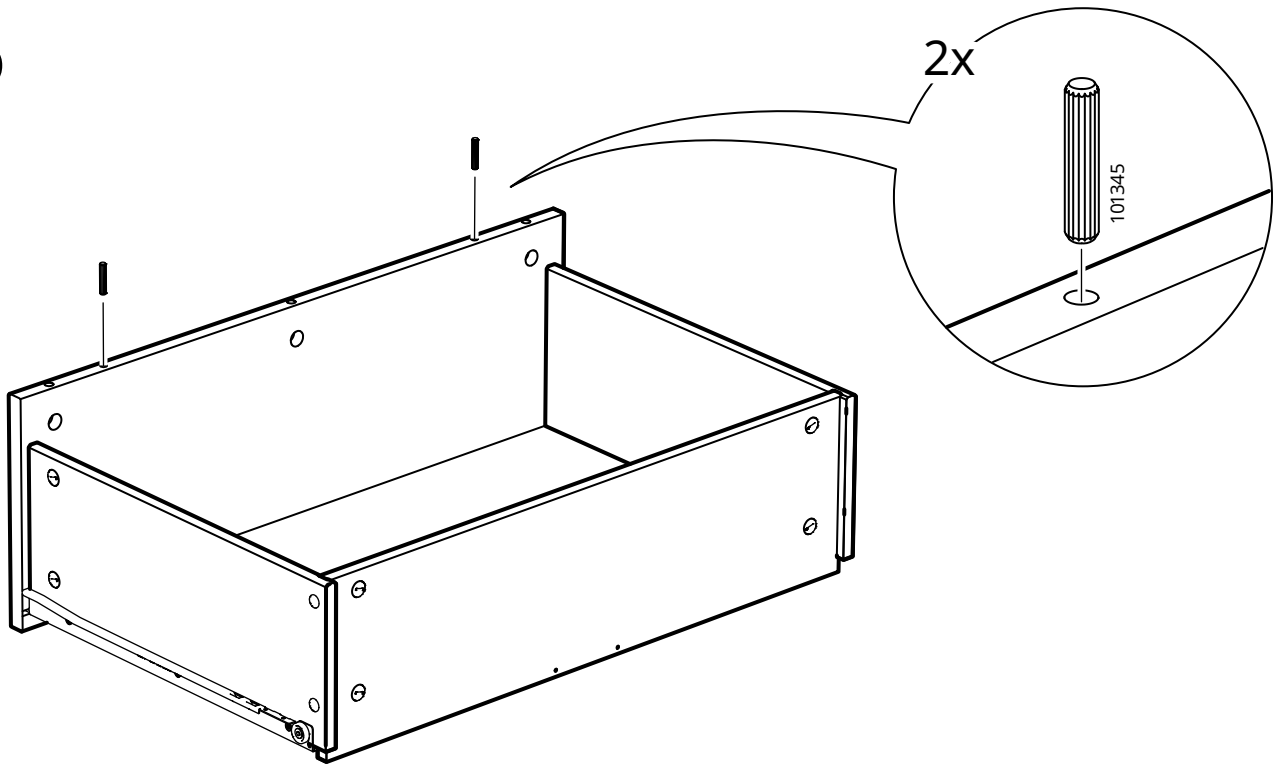

67

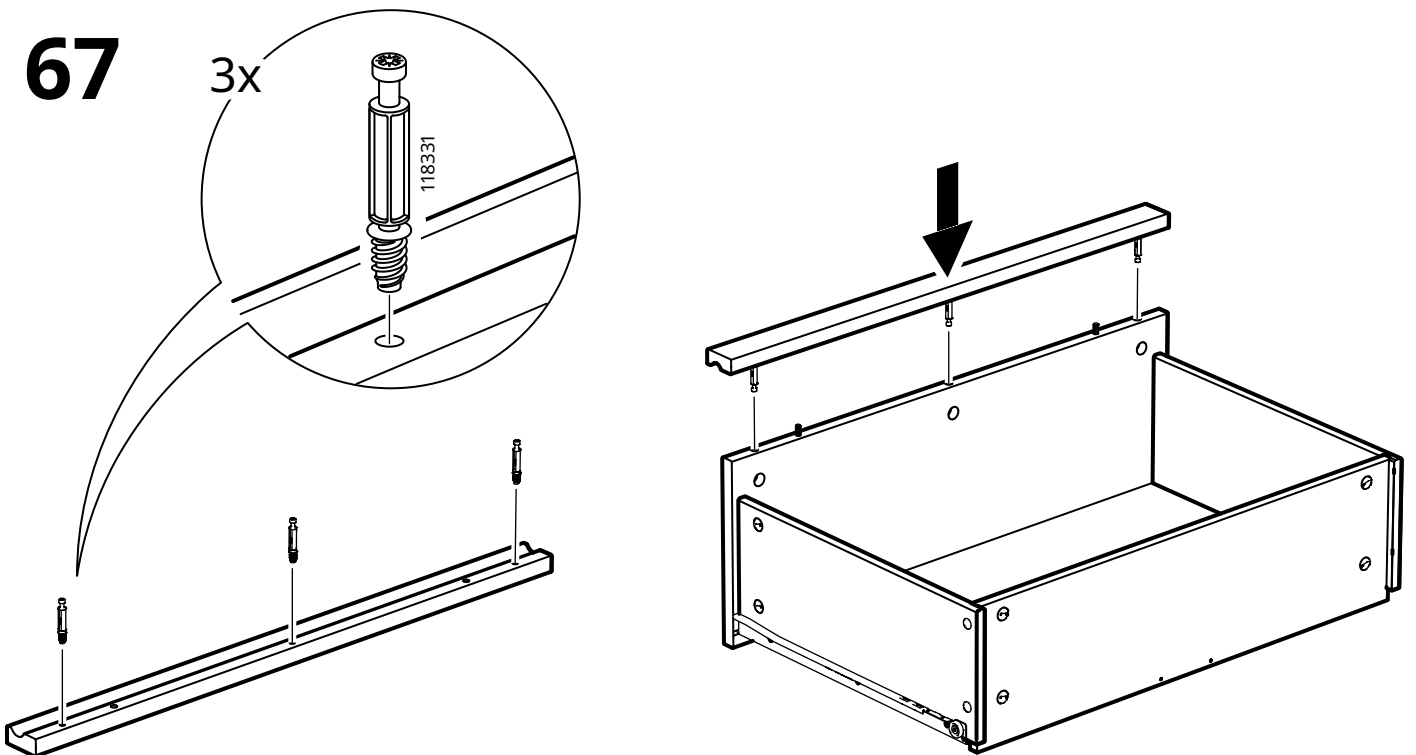

68

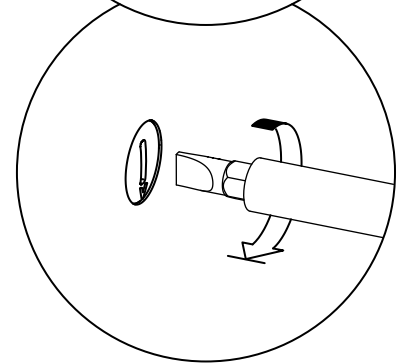
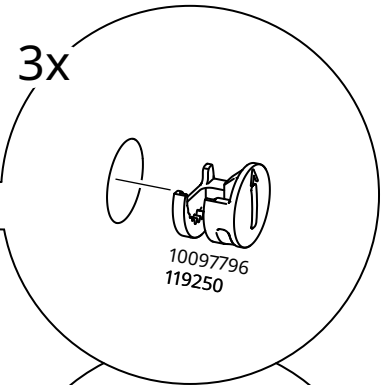
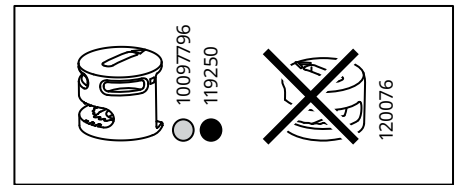
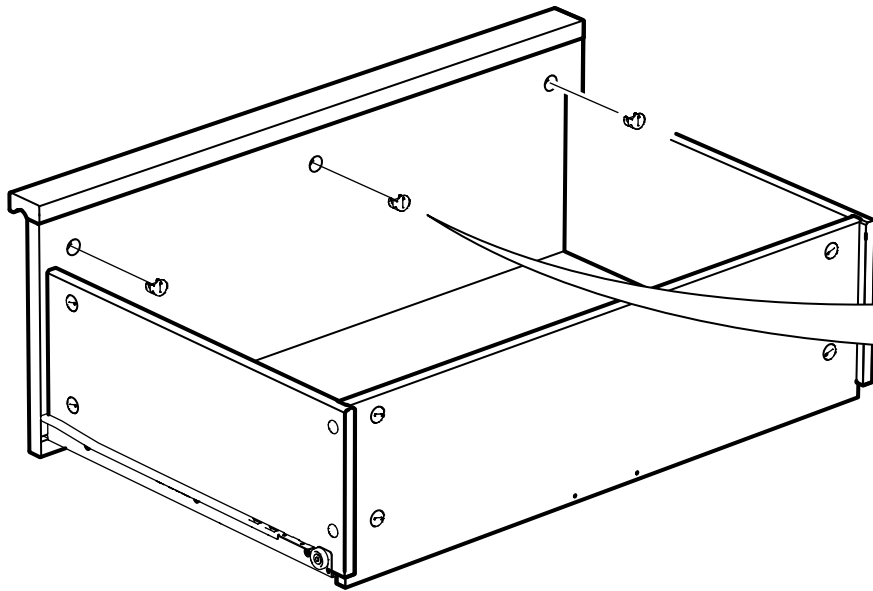

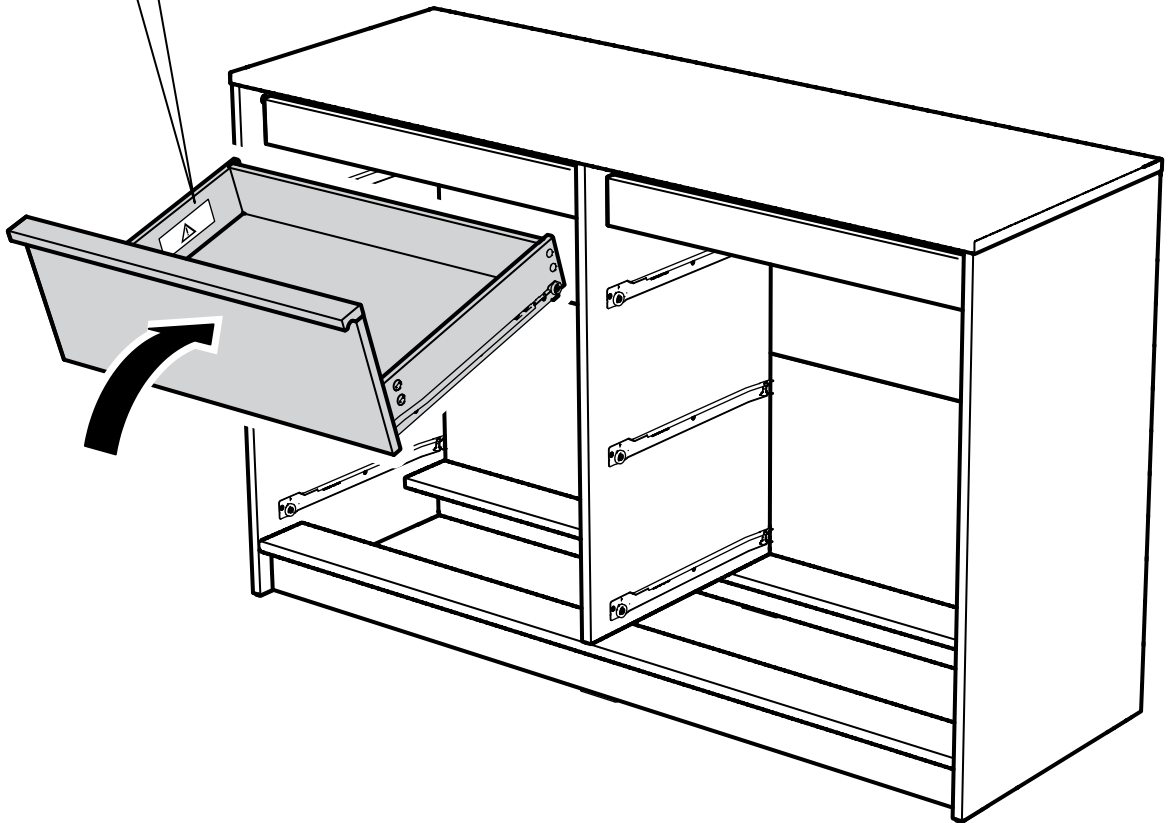
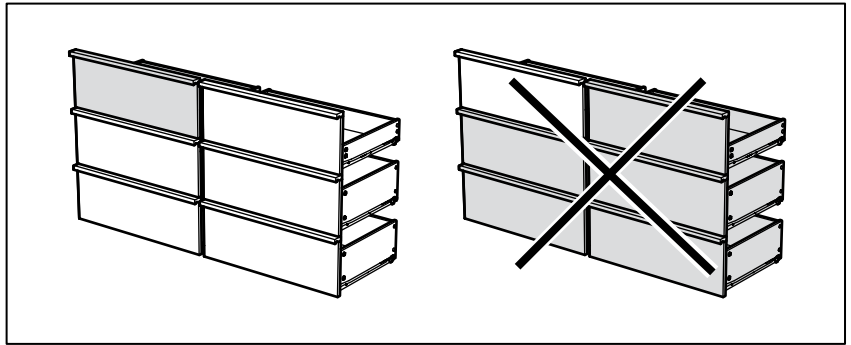

70

