

FRILLESBO

en



Design and Quality
IKEA of Sweden

ENGLISH

4

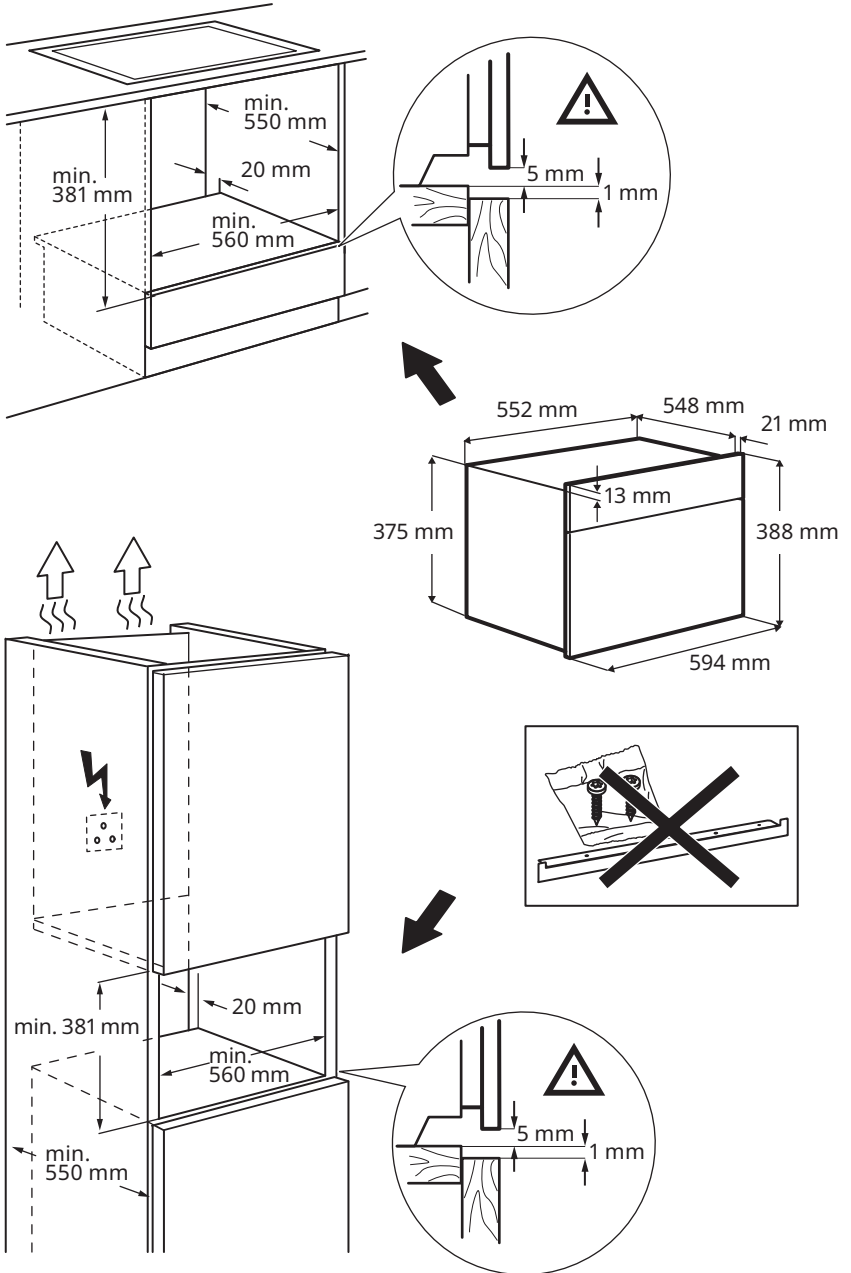

Safety Information

Before the installation and use of the appliance, carefully read the supplied instructions. The manufacturer is not responsible for any injuries or damage that are the result of incorrect installation or usage. Always keep the instructions in a safe and accessible location for future reference.

SAFETY WARNINGS

⚠ This appliance can be used by children aged from 8 years and above and persons with reduced physical, sensory or mental capabilities or lack of experience and knowledge if they have been given supervision or instruction concerning the use of the appliance in a safe way and understand the hazards involved. Children of less than 8 years of age and persons with very extensive and complex disabilities shall be kept away from the appliance unless continuously supervised. Children must not play with the appliance. Keep all packaging away from children and dispose of it appropriately. Children shall not carry out cleaning and user maintenance of the appliance without supervision. If the appliance has a child safety device, it should be activated.

⚠ This appliance is for cooking purposes only.

⚠ This appliance is designed for single household domestic use in an indoor environment.

⚠ This appliance may be used in, offices, hotel guest rooms, bed & breakfast guest rooms, farm guest houses and other similar accommodation where such use does not exceed (average) domestic usage levels.

⚠ **WARNING:** The appliance and its accessible parts become hot during use. Care should be taken to avoid touching heating elements.

⚠ **WARNING:** Ensure that the appliance is switched off before replacing the lamp to avoid the possibility of electric shock.

- ⚠ If the supply cord is damaged, it must be replaced with an identical one by the manufacturer, its service agent or similarly qualified persons in order to avoid a hazard - risk of electrical shock.
- ⚠ Do not change the specification of this appliance.
- ⚠ To remove the shelf supports first pull the front of the shelf support and then the rear end away from the side walls. Install the shelf supports in the opposite sequence.
- ⚠ Always cook with the oven door closed. Use oven gloves to remove pans and accessories.
- ⚠ Do not use a steam cleaner to clean the appliance. Do not use harsh abrasive cleaners or sharp metal scrapers to clean the glass door since they can scratch the surface, which may result in shattering of the glass.
- ⚠ The means for disconnection must be incorporated in the fixed wiring in accordance with the wiring rules.
- ⚠ Use only the food sensor (core temperature sensor) recommended for this appliance (if applicable).

Permitted use

- ⚠ Risk of injury, burns, electric shock, fire, explosion or damage to the appliance.
- ⚠ This appliance is for cooking purposes only. It must not be used for other purposes, for example room heating.
- ⚠ Do not let the appliance stay unattended during operation. Deactivate the appliance after each use. Make sure that the ventilation openings are not blocked.
- ⚠ Keep clothes or other flammable materials away from the appliance, until all the components have cooled down completely - risk of fire.
- ⚠ If the appliance is installed behind a furniture panel (e.g. a door) make sure the door is never closed when the appliance operates. Heat and moisture can build up behind a closed furniture panel and cause subsequent damage to the appliance, the furniture or the floor. Do not close the furniture panel until the appliance has cooled down after use.
- ⚠ Do not operate the appliance with wet hands or when it has contact with water. Do not apply pressure on the open door. Be careful when you remove the door from the appliance. The door is heavy. Do not use the appliance as a work surface or as a storage surface.
- ⚠ Be careful when you open the appliance door while the appliance is in operation. Hot air can release. Do not put flammable products or items that are wet with flammable products in, near or on the

appliance. When you place food into hot oil, it may splash. Do not let sparks or open flames to come in contact with the appliance when you open the door. Open the appliance door carefully. The use of ingredients with alcohol can cause a mixture of alcohol and air.

 To prevent damage or discolouration to the enamel:

- Do not put ovenware or other objects in the appliance directly on the bottom.
- Do not put aluminium foil directly on the bottom of cavity of the appliance.
- Do not put water directly into the hot appliance.
- Do not keep moist dishes and food in the appliance after you finish the cooking.
- Be careful when you remove or install the accessories.

 Use a deep pan for moist cakes. Fruit juices cause stains that can be permanent. Discolouration of the enamel or stainless steel has no effect on the performance of the appliance.

 Clean the appliance regularly to prevent the deterioration of the surface material.

Before maintenance, deactivate the appliance and disconnect from the mains. Ensure the appliance is cooled down before any cleaning or maintenance - risk of burn. Be careful when you remove the door from the appliance. The door is heavy. There is also the risk that the glass panels can break. Replace door glass panels immediately if they are damaged. Contact the Authorised Service Centre.

 Clean the appliance with a moist soft cloth. Use only neutral detergents. Do not use abrasive products, abrasive cleaning pads, solvents or metal objects. Do not clean the catalytic enamel with detergents (if applicable). Fat and food remaining in the appliance can cause fire. Do not remove the knobs from the appliance (if applicable). If you use an oven spray, follow the safety instructions on its packaging.

 Before disposal, remove the door catch to prevent children or pets from becoming trapped inside the appliance - the risk of injury or suffocation.

Installation

 The appliance must be handled and installed by two or more persons - risk of injury. Always use safety gloves and enclosed footwear - risk of cuts.

 Installation, including water supply (if any) and electrical connections, service or repair operation that involves the removal of a cover which gives protection against exposure to microwave energy (if any) and repairs must be carried out by the authorised installer. Follow the assembly instructions supplied with the appliance. Remove all the packaging. Make sure that the appliance has not been damaged during transport. In the event of problems, contact the dealer or your nearest Authorised

Service Centre. Do not install or use a damaged appliance.

 Install the appliance in a safe and suitable place that meets installation requirements. Do not use the appliance before installing it in the built-in structure. Do not pull the appliance by the handle. Keep the minimum distance from other appliances and units. Before mounting the appliance, check if the oven door opens without restraint.

 Ensure that the appliance is switched off and disconnected from the power supply before performing any maintenance operation - risk of electric shock. During installation, make sure the appliance does

not damage the power cable - risk of fire or electric shock. Only activate the appliance when the installation has been completed.

 Do not obstruct the minimum gap between the worktop and the upper edge of the oven - risk of burns.

Electrical warnings

 Risk of fire and electric shock.

 Make sure that the parameters on the rating plate are compatible with the electrical ratings of the mains power supply.

 Do not use extension leads, multi-plug sockets or adapters. Do not operate the appliance if it has a damaged power cable or plug, if it is not working properly, or if it has been damaged or dropped. The appliance must be earthed. Always use a correctly installed shockproof socket. The shock protection of live and insulated parts must be fastened in such a way that it cannot be removed without tools. The electrical components must not be accessible to the user after installation.

 The electrical installation must have an isolation device which lets you disconnect the appliance from the mains at all poles. The isolation device must have a contact opening width of minimum 3 mm. Use only correct isolation devices: line protecting cutouts, fuses (screw type fuses removed from the holder), earth leakage trips and contactors.

 Connect the mains plug to the mains socket only at the end of the installation. Fully close the appliance door before you

connect the mains plug to the mains socket. Make sure that there is access to the mains plug after the installation. If the mains socket is loose, do not connect the mains plug. Do not pull the mains cable to disconnect the appliance. Always pull the mains plug. Do not let mains cables touch or come near the appliance door or the niche below the appliance, especially when it operates or the door is hot.

 To replace the power cable, contact the Authorised Service Centre.

 This product contains a light source of energy efficiency class G.

 Concerning the lamp(s) inside this product and spare part lamps sold separately: These lamps are intended to withstand extreme physical conditions in household appliances, such as temperature, vibration, humidity, or are intended to signal information about the operational status of the appliance. They are not intended to be used in other applications and are not suitable for household room illumination.

 Before disposal, disconnect the appliance from the mains supply. Cut off the mains electrical cable close to the appliance and dispose of it.

Energy saving tips

NOTE: This appliance has features which help you save energy during everyday cooking.

Make sure that the oven door is closed properly when the oven operates. Do not open the door too often during cooking. Keep the door gasket clean and make sure it

is well fixed in its position. Use metal dishes to improve energy saving. When possible, do not preheat the oven before you put the food inside.

When the cooking duration is longer than 30 minutes, reduce the oven temperature to minimum 3 - 10 minutes before the end of

the cooking time, depending on the duration of the cooking. The residual heat inside the oven will continue to cook.

Use the residual heat to warm up other dishes. Keep breaks between baking as short as possible when you prepare few dishes at one time. Choose the lowest possible temperature setting to use residual heat and keep a meal warm.

When possible, use the cooking functions with fan to save energy.

If a programme with the Duration or End Time selection is activated and the cooking

time is longer than 30 minutes, the heating elements automatically deactivate earlier in some oven functions (if applicable).

When possible, turn off the lamp during cooking. Turn it on only when you need it.

Moist Fan Baking (if applicable): Function designed to save energy during cooking. When you use this function the lamp automatically turns off.

Care and cleaning

Warning! Refer to Safety chapters.

Notes on cleaning

Cleaning agents

- Clean the front of the appliance only with a microfibre cloth with warm water and a mild detergent.
- Use a cleaning solution to clean metal surfaces.
- Clean stains with a mild detergent.

Everyday use

- Clean the interior of the appliance after each use. Fat accumulation or other residue may cause fire.
- Do not store food in the appliance for longer than 20 minutes. Dry the interior of the appliance only with a microfibre cloth after each use.

Accessories

- Clean all accessories after each use and let them dry. Use only a microfibre cloth with warm water and a mild detergent. Do not clean the accessories in a dishwasher.
- Do not clean the non-stick accessories using abrasive cleaner or sharp-edged objects.

Removing the shelf supports

Remove the shelf supports to clean the appliance.

1. Turn off the appliance and wait until it is cold.
2. Pull the front of the shelf support away from the side wall.
3. Pull the rear end of the shelf support away from the side wall and remove it.

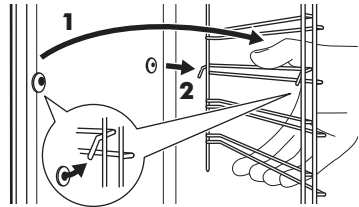

4. Put the shelf supports back to the initial position. Repeat the steps in the reverse order.

If the telescopic runners are supplied, its retaining pins must point to the front.

Removing and installing door

You can remove the door and the internal glass panels to clean it. The number of glass panels is different for different models.

Warning! The door is heavy.

⚠ Caution! Carefully handle the glass, especially around the edges of the front panel. The glass can break.

1. Make sure the appliance is cold.
2. Fully open the door.
3. Press the clamping levers **A** on the two door hinges.

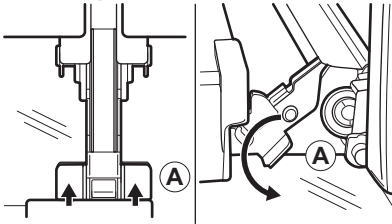

4. Close the oven door to the first opening position (at approximate angle: 70°).
5. Hold the door with one hand on each side and pull it away from the oven at an upwards angle.
6. Put the door with the outer side down on a soft cloth on a stable surface.
7. Hold the door trim **B** on the top edge of the door at the two sides and push inwards to release the clip seal.

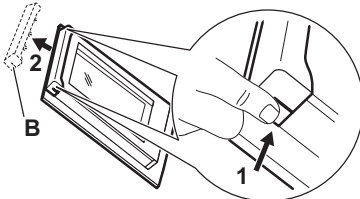

8. Pull the door trim to the front to remove it.
9. Hold the door glass panels on their top edge one by one and pull them up out of the guide.

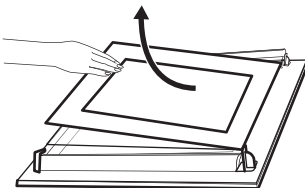

10. Clean the glass panel with water and soap. Dry the glass panel carefully. Do not clean the glass panels in the dishwasher.

After cleaning, do the above steps in the opposite sequence. Install the smaller panel first, then the larger and the door.

Make sure that the glass panels are inserted in the correct position otherwise the surface of the door may overheat.

Replacing the lamp

⚠ Warning! Risk of electric shock.

⚠ Warning! Risk of injury when removing the glass cover.

⚠ Warning! Risk of burns, the glass cover may be hot. Use protective glove when touching the lamp.

1. Turn off the appliance. Wait until the appliance is cold.
2. Disconnect the appliance from the mains.
3. Use a Torx 20 screwdriver to remove the glass cover.
4. Remove and clean the metal frame and the seal.
5. Replace the lamp with a suitable 300°C heat-resistant lamp.
6. Install the metal frame and the seal. Tighten the screws.

Environmental concerns

Recycle materials with the symbol . Put the packaging in relevant containers to recycle it. Help protect the environment and human health by recycling waste of electrical and electronic appliances. Do not dispose of

appliances marked with the symbol  with the household waste. Return the product to your local recycling facility or contact your municipal office.

IKEA guarantee

How long is the IKEA guarantee valid?

This guarantee is valid for 5 years from the original date of purchase of your appliance at IKEA. The original sales receipt is required as proof of purchase. If service work is carried out under guarantee, this will not extend the guarantee period for the appliance.

Who will execute the service?

IKEA service provider will provide the service through its own service operations or authorized service partner network.

What does this guarantee cover?

The guarantee covers faults of the appliance, which have been caused by faulty construction or material faults from the date of purchase from IKEA. This guarantee applies to domestic use only. The exceptions are specified under the headline "What is not covered under this guarantee?" Within the guarantee period, the costs to remedy the fault e.g. repairs, parts, labour and travel will be covered, provided that the appliance is accessible for repair without special expenditure. On these conditions the EU guidelines (Nr. 99/44/EG) and the respective local regulations are applicable. Replaced parts become the property of IKEA.

What will IKEA do to correct the problem?

IKEA appointed service provider will examine the product and decide, at its sole discretion, if it is covered under this guarantee. If considered covered, IKEA service provider or its authorized service partner through its

own service operations, will then, at its sole discretion, either repair the defective product or replace it with the same or a comparable product.

What is not covered under this guarantee?

- Normal wear and tear.
- Deliberate or negligent damage, damage caused by failure to observe operating instructions, incorrect installation or by connection to the wrong voltage, damage caused by chemical or electro-chemical reaction, rust, corrosion or water damage including but not limited to damage caused by excessive lime in the water supply, damage caused by abnormal environmental conditions.
- Consumable parts including batteries and lamps.
- Non-functional and decorative parts which do not affect normal use of the appliance, including any scratches and possible color differences.
- Accidental damage caused by foreign objects or substances and cleaning or unblocking of filters, drainage systems or soap drawers.
- Damage to the following parts: ceramic glass, accessories, crockery and cutlery baskets, feed and drainage pipes, seals, lamps and lamp covers, screens, knobs, casings and parts of casings. Unless such damages can be proved to have been caused by production faults.
- Cases where no fault could be found during a technician's visit.

- Repairs not carried out by our appointed service providers and/or an authorized service contractual partner or where non-original parts have been used.
- Repairs caused by installation which is faulty or not according to specification.
- The use of the appliance in a non-domestic environment i.e. professional use.
- Transportation damages. If a customer transports the product to their home or other address, IKEA is not liable for any damage that may occur during transport. However, if IKEA delivers the product to the customer's delivery address, then damage to the product that occurs during this delivery will be covered by this guarantee.
- Cost for carrying out the initial installation of the IKEA appliance. However, if an IKEA service provider or its authorized service partner repairs or replaces the appliance under the terms of this guarantee, the service provider or its authorized service partner will re-install the repaired appliance or install the replacement, if necessary.

This restriction do not apply to fault-free work carried out by a qualified specialist using our original parts in order to adapt the appliance to the technical safety specifications of another EU country.

How country law applies?

The IKEA guarantee gives you specific legal rights, which covers or exceed local demands. However these conditions do not limit in any way consumer rights described in the local legislation.

Area of validity

For appliances which are purchased in one EU country and taken to another EU country, the services will be provided in the framework of the guarantee conditions normal in the new country. An obligation to carry out services in the framework of the guarantee exists only if the appliance complies and is installed in accordance with:

- the technical specifications of the country in which the guarantee claim is made;
- the Assembly Instructions and User Manual Safety Information;

The dedicated After Sales Service for IKEA appliances:

Please do not hesitate to contact IKEA After Sales Service to:

1. make a service request under this guarantee;
2. ask for clarification on installation of the IKEA appliance in the dedicated IKEA kitchen furniture. The service won't provide clarifications related to:
 - the overall IKEA kitchen installation;
 - connections to electricity (if machine comes without plug and cable), to water and to gas since they have to be executed by an authorized service engineer.
3. ask for clarification on user manual contents and specifications of the IKEA appliance.

To ensure that we provide you with the best assistance, please read carefully the Assembly Instructions and/or the User Manual section of this booklet before contacting us.

How to reach us if you need our service?



Please refer to the last page of this manual for the full list of IKEA appointed contacts and relative national phone numbers.

i In order to provide you with a quicker service, we recommend that you use the specific phone numbers listed at the end of this manual. Always refer to the numbers listed in the booklet of the specific appliance you need an assistance for. Before calling us, assure that you have to hand the IKEA article number (8 digit code) and the Serial Number (8 digit code that can be found on the rating plate) for the appliance of which you need our assistance.

i **SAVE THE SALES RECEIPT!** It is your proof of purchase and required for the guarantee to apply. Note that the receipt reports also the IKEA article name and number (8 digit code) for each of the appliances you have purchased.

Do you need extra help?

For any additional questions not related to After Sales of your appliances, please contact our nearest IKEA store call centre. We recommend you read the appliance documentation carefully before contacting us.

Country	Phone number	Call Fee	Opening time
België	02/716.24.44	Binnenlandse gesprekskosten	8 tot 18.30 Weekdagen Zaterdag 9 tot 13u
Belgique		Tarif des appels nationaux	8 à 18.30 en semaine Samedi 9 à 13h
България	+359 2 492 9397	Според тарифата на оператора за обаждания към стационарен номер	От 8:30 до 17:30 ч в работни дни
Česká Republika	246 019721	Cena za místní hovor	8 až 20 v pracovních dnech
Danmark	70 15 09 09	Landstakst	man. - fre. 09.00 - 20.00 lør. - søn. 09.00 - 18.00
Deutschland	+49 (0)911 323 1016*	* 0,20 €/Verbindung aus dem Fest-netz max. 0,60 €/Verbindung aus dem Mobilfunknetz	Werktags von 8.00 bis 20.00
Ελλάδα	211 176 8276	Υπεραστική κλήση	8 έως 20 κατά τις εργάσιμες ημέρες
España	91 1875537	Tarifa de llamadas nacionales	De 8 a 20 en días laborables
France	0170 36 02 05	Tarif des appels nationaux	9 à 21. En semaine
Hrvatska	00385 1 6323 339	Cijena ovisi o pružatelju telefonske usluge korisnika	radnim danom od ponedjeljka do petka od 08:00 do 16:00
Ireland	0 14845915	National call rate	8 till 20 Weekdays
Ísland	+354 5852409	Innanlandsgjald fyrir síma	9 til 18. Virka daga
Italia	02 00620818	Tariffa applicata alle chiamate nazionali	dalle 8 alle 20 nei giorni feriali
Κυπρος	22 030 529	Υπεραστική κλήση	8.30 έως 16.30 κατά τις εργάσιμες ημέρες
Lietuva	5 230 06 99	Nacionalinių pokalbių tarifai	Pr. - Ketv.: 8:00 - 12:00; 12:45 - 17:00 Pnkt.: 8:00 - 12:00; 12:45 - 15:45
Luxembourg	35242431301	Tarif des appels nationaux	Lu-Ven 8:00-12:00/13:00-17:00
Magyarország	06-1-252-1773	Belföldi díjszabás	Hétköznap 8.00 és 17.00 óra között
Nederland	0172/468568	Geen extra kosten. Alleen lokaal tarief	ma-vr: 8:00 - 18:30 zat: 9:00 - 13:00
Norge	22 72 35 00	Takst innland	8 til 18 ukedager
Österreich	+43-1-2056356	max. 10 Cent/min.	Mo - Fr 8.00 - 20.00 Uhr
Polska	801 400 711 +48 22 749 60 99	Koszt zgodny z taryfą operatora	Od 8 do 20 w dni robocze
Portugal	211557985	Chamada Nacional	9 às 21. Dias de Semana *excepto feriados
România	021 211 08 88	Tarif apel național	8 - 20 în zilele lucrătoare
Россия	8 495 6662929	Действующие телефонные тарифы	с 8 до 20 по рабочим дням Время московское
Schweiz	031 5500 324	Tarif für Anrufe im Bundesgebiet	8 bis 20 Werktage
Suisse		Tarif des appels nationaux	8 à 20. En semaine
Svizzera		Tariffa applicata alle chiamate nazionali	dalle 8 alle 20 nei giorni feriali
Slovenija	+38618108621	lokalni strošek je običajna tržna vrednost, odvisna od ponudnika telefonije	8.00 - 16.00 ob delavnikih
Slovensko	(02) 3300 2554	Cena vnútroštátneho hovoru	8 až 20 v pracovných dňoch
Suomi	030 6005203	pvm/mpm	Ma - To 8:00 -18:00 Pe 9:00 -16:00
Sverige	0775 700 500	lokalsamtal (lokal taxa)	mån-fre 8.30 - 20.00 lör-sön 9.30 - 18.00
United Kingdom	020 3347 0044	National call rate	9 till 21. Weekdays
Србија	+381 11 7 555 444 (ако позивате изван Србије) 011 7 555 444 (ако позивате из Србије)	Цена позива у националном саобраћају	Понедељак – субота: 09 – 20 Недеља: 09 – 18
Eesti, Latvija, Ukraina		www.ikea.com	



701138130-A-392025

