

MYLLRA

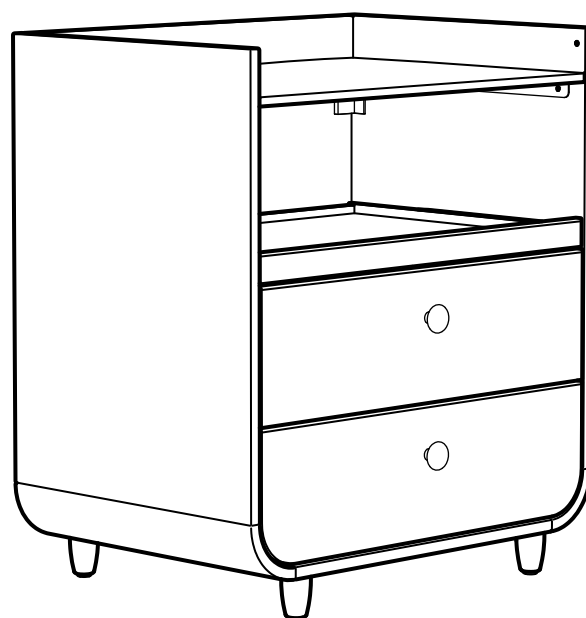

Design and Quality
IKEA of Sweden

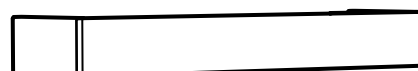
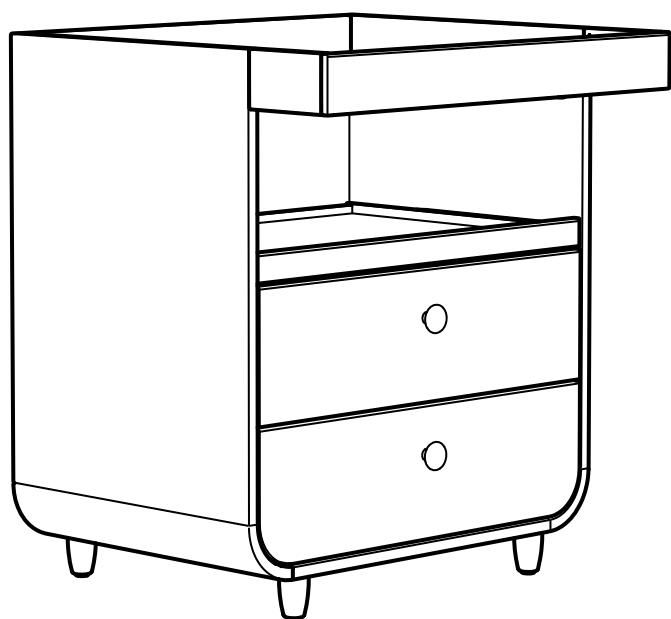
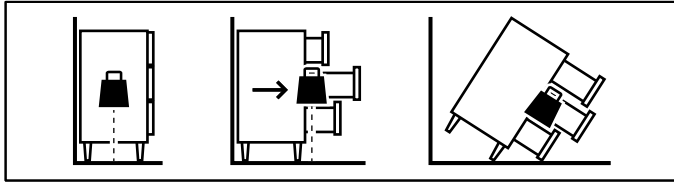

English

WARNING!

Serious or fatal crushing injuries can occur from furniture tip-over. To reduce the risk of furniture tip-over:

ALWAYS secure this furniture to the wall using tip-over restraints.

To further reduce the risk of serious injury and death from tip-overs:

Place heaviest items in the lower drawer.

Do not set TVs or other heavy objects on top of this product.

Never let children climb or hang on drawers, doors, or shelves.

Read and follow each step of the instruction carefully.

Deutsch

ACHTUNG!

Umfallende Möbelstücke können lebensgefährlich sein. Um die Gefahr umkippender Möbel zu vermeiden:

Um diesem Risiko zu entgehen, muss das Möbel **UNBEDINGT** mit dem beigegepackten Kippenschutz an der Wand befestigt werden.

Um das Risiko schwerer oder gar tödlicher Verletzungen durch umkippende Möbelstück weiter zu mindern, bitte Folgendes beachten:

Die schwersten Gegenstände in die untersten Schubladen stellen.

Fernsehgeräte oder andere schwere Geräte niemals auf das Produkt stellen.

Kindern niemals erlauben, auf Schubladen, Türen und Regale zu klettern oder sich daran zu hängen.

Die Anleitung sorgfältig lesen und Schritt für Schritt befolgen.

Français

AVERTISSEMENT !

Il existe un risque de blessures graves ou mortelles en cas de basculement du meuble. Afin de limiter le risque de basculement d'un meuble :

TOUJOURS fixer ce meuble au mur à l'aide des fixations antibasculement.

Pour encore réduire les risques de blessures graves ou mortelles dus au basculement du meuble :

Placer les choses les plus lourdes dans le tiroir du bas.

Ne pas poser de TV ou d'objet lourd sur le dessus de ce produit.

Ne jamais laisser les enfants grimper ou s'accrocher aux tiroirs, portes ou tablettes.

Lire et suivre attentivement toutes les étapes de la notice de montage.

Nederlands

WAARSCHUWING!

Opbergmeubels die omvallen kunnen ernstig of levensbedreigend letsel veroorzaken. Om het risico te verkleinen dat het meubel omvalt:

Om dat te voorkomen dient het meubel **ALTIJD** met het meegeleverde kantelbeslag aan de muur te worden bevestigd.

Om het risico op kantelende voorwerpen en daarmee ernstig letsel of dodelijke ongevallen nog verder te vermijden, is het verstandig hiermee rekening te houden:

Plaats de zwaarste spullen in de onderste lades.

Zet nooit een tv of andere zware voorwerpen op het meubel.

Laat kinderen nooit op lades, deuren, planken of kasten klimmen of eraan gaan hangen.

Lees en volg elke stap van de instructies zorgvuldig.

Dansk

ADVARSEL!

Man kan komme alvorligt eller livsfarligt til skade, hvis møblet vælter. For at reducere risikoen for, at møblet vælter: Møblet skal **ALTID** fastgøres til væggen med væltesikringer.

For yderligere at reducere risikoen for alvorlig tilskadecomst og dødsfald som følge af vælteulykker:

Placer de tungeste ting i de nederste skuffer.

Placer ikke et tv eller andre tunge genstande oven på dette produkt.

Sørg for, at børn ikke klatrer eller hænger i skuffer, låger eller hylder.

Læs og følg omhyggeligt hvert enkelt trin i anvisningerne.

Íslenska

VARÚÐ!

Alvarleg eða lífshættuleg meiðsli geta orðið ef húsgagn fellur fram fyrir sig. Dragðu úr hættu á að húsgagn falli fram fyrir sig:

Þetta húsgagn á alltaf að vera fest við vegg með festingum.

Til að draga úr hættu á alvarlegum meiðslum og dauða vegna falls húsgagns: Setjið þyngstu hlutina í lægri skúffuna.

Setjið ekki sjónvörp eða önnur þung tæki ofan á þessa vöru.

Leyfið aldrei börnum að klifra eða hanga á skúffum, hurðum eða hillum.

Lestu leiðbeiningarnar og fylgdu hverju skrefi þeirra vandlega.

Norsk

ADVARSEL

Alvorlige ulykker kan skje som følge av møbler som velter. For å redusere faren for at møbler velter:

Fest ALLTID møbelet til veggen det medfølgende anti-velt-beslaget.

For å redusere faren ytterligere for at veltende gjenstander forårsaker alvorlige eller dødelige skader:

Legg de tyngste tingene i den nederste skuffen.

Plasser aldri TV-apparater eller andre tunge gjenstander oppå møbelet.

La aldri barn klatre eller henge på skuffer, dører eller hyller.

Les og følg hvert steg i instruksene nøye.

Suomi

VAROITUS!

Kalusteen kaatuminen voi aiheuttaa vakavia vammoja. Kalusteen kaatumista voi ehkäistä seuraavasti:

Kalusteet on **AINA** kiinnitettävä seinään tuotteeseen kuuluvalla kiinnitysrautkaisulla.

Kalusteen kaatumiseen liittyvän loukkaantumisen ja menehtymisriskin minimoimiseksi huomioi seinään kiinnittämisen lisäksi myös seuraavat asiat:

Sijoita raskaimmat tavarat alalaatikoon.

Älä sijoita tv:tä tai muita raskaita esineitä tämän tuotteen päälle.

Älä anna lasten roikkua tai kiipeillä laatikoissa, ovissa tai hyllyillä.

Lue ohjeet kohta kohdalta ja noudata niitä huolellisesti.

Svenska

VARNING!

Förvaringsmöbler som välter kan orsaka allvarliga eller livshotande skador.

För att undvika detta ska du **ALLTID** fästa möbelen i väggen med tippskyddsbeslag.

För att ytterligare minimera risken för att vältande föremål orsakar allvarliga eller dödliga skador bör du tänka på följande:

Placera alltid tunga föremål längst ner.

Placera aldrig TV-apparater eller andra tunga föremål ovanpå möbelen.

Tillåt aldrig barn att klättra eller hänga på lådor, dörrar eller hyllor.

Läs och följ varje steg av instruktionerna noggrant.

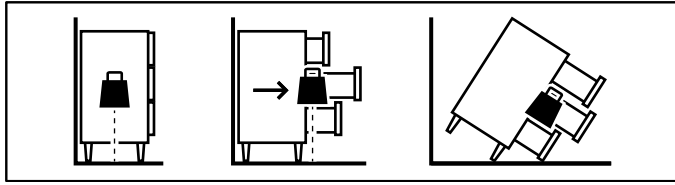

Česky VAROVÁNÍ!

Převržení nábytku může mít vážné nebo fatální následky. Abyste snížili riziko převržení nábytku:

VŽDY připevněte tento nábytek ke stěně pomocí přiloženého kování.

Abyste ještě více snížili riziko vážného zranění nebo smrti z převržení nábytku, řiďte se těmito pokyny:

Nejtěžší věci umístěte do spodní zásuvky.

Na tento výrobek nedávejte televize nebo jiné těžké předměty.

Nenechte děti šplhat nebo se zavěsit na zásuvky, dvířka nebo police.

Pečlivě si přečtěte a dodržujte jednotlivé kroky uvedené v montážním návodu.

Español ADVERTENCIA:

Si el mueble volcase, podría provocar lesiones graves e incluso mortales. Para limitar el riesgo de vuelco de los muebles:

Fija SIEMPRE el mueble a la pared con herrajes antivuelco.

Para reducir más el riesgo de daños graves o mortales por el vuelco del mueble:

Coloca los objetos más pesados en el cajón inferior.

No pongas la televisión u otros objetos pesados en la parte superior del mueble.

Nunca permitas que los niños trepen o se cuelguen de los cajones, baldas o puertas.

Lee y sigue cada paso de las instrucciones cuidadosamente.

Italiano AVVERTENZA!

Se il mobile si ribalta può causare lesioni da schiacciamento gravi o mortali. Per ridurre il rischio di ribaltamento dei mobili:

Fissa SEMPRE questo mobile alla parete usando i componenti antiribaltamento di sicurezza.

Per ridurre ulteriormente il rischio di lesioni gravi o mortali causate dal ribaltamento:

Metti gli oggetti più pesanti nel cassetto inferiore.

Non collocare la TV o altri oggetti pesanti su questo prodotto.

Non lasciare che i bambini si appendano o si arrampichino sui cassetti, sulle ante o sui ripiani.

Leggi e segui attentamente ogni fase delle istruzioni.

Magyar FIGYELEM!

Súlyos vagy végzetes sérüléseket okozhatnak a felboruló bútorok. A felborulás kockázatának csökkentése érdekében:

MINDIG rögzítsd a bútort a falhoz a borulásgátlók segítségével.

A felborulás miatti komoly vagy halálos sérülések kockázatának továbbbi csökkentéséhez:

A nehezebb dolgokat helyezd az alsó fiókba.

Ne helyezd TV-t, vagy egyéb nehéz tárgyat a termék tetejére.

Ne engedd, hogy a gyerekek felmásszanak a fiókokra, az ajtókra, vagy a polcokra, és azokról lógjanak.

Figyelmesen olvasd el az útmutatót és kövesd az abban leírtakat!

Polski OSTRZEŻENIE!

Na skutek przewrócenia się mebla może dojść do poważnych obrażeń lub śmierci. W celu ograniczenia ryzyka przewrócenia się mebla:

ZAWSZE mocuj ten mebel do ściany za pomocą zabezpieczeń przed przewróceniem.

Aby dodatkowo zmniejszyć ryzyko poważnych obrażeń lub śmierci na skutek przewrócenia się mebla:

Umieszczaj najcięższe przedmioty w dolnej szufladzie.

Nie stawiaj na meblu telewizora ani innych ciężkich przedmiotów.

Nigdy nie pozwalaj dzieciom wieszać się na szufladach, drzwiczkach bądź półkach ani się na nie wspinać.

Dokładnie przeczytaj instrukcję i postępuj zgodnie z każdym jej punktem.

Eesti HOIATUS!

Mööbli ümberkukkumisele võivad järgneda rängad või surmaga lõppevad vigastused. Ümberkukkumisohtu vähendamiseks:

KINNITA see mööbliese seinale külge, kasutades vastavaid kinnitusi.

Et vigastus- või surmaohtu veelgi vähendada:

Pane raskemad esemed alumistesse sahtlitesse.

Ära paiguta selle toote peale telerit või teisi raskeid esemeid.

Ära kunagi lase lastel ronida või rippuda sahtlitel, ustel või riulitel.

Loe kogu kasutusjuhend läbi ja järgi seda hoolikalt.

Latviešu BRĪDINĀJUMS!

Apgāžoties mēbeles var izraisīt nopietnas vai pat nāvējošas traumas. Lai samazinātu mēbeļu apgāšanās risku:

VIENMĒR piestiprināt mēbeles pie sienas, izmantojot drošības stiprinājumus.

Lai maksimāli izvairītos no nopietnu vai nāvējošu traumu riska:

Smagākos priekšmetus likt apakšējā atvilktnē.

Uz šīs preces nedrīkst novietot televizoru vai citus smagus priekšmetus.

Neļaut bērniem rāpties uz atvilktnēm, durvīm vai plauktiem vai karāties, turoties pie šiem elementiem.

Rūpīgi izlasīt un ievērot lietošanas instrukciju.

Lietuvių ĮSPĖJIMAS

Užvirtus baldams galima patirti sunkių arba mirtinų traumų. Tam, kad baldų užvirtimo rizika būtų mažesnė:

VISADA pritvirtinkite baldus prie sienos tam skirtais laikikliais.

Kad dar labiau sumažintumėte sunkių sužalojimų ir mirties riziką dėl užvirtimo:

Sunkiausias daiktus dėkite į apatinį stalčių.

Niekada nelaikykite ant šio gaminio televizoriaus, įrangos ir kitų sunkių daiktų.

Neleiskite vaikams karštytis stalčiais, drelėmis ar lentynomis ir ant jų kyboti.

Atidžiai perskaitysite nurodymus ir atliksite visus nurodytus veiksmus.

Português AVISO!

Podem ocorrer ferimentos graves ou fatais devido à queda de móveis. Para diminuir o risco de queda de móveis:

Fixe SEMPRE este móvel à parede com acessórios de fixação.

Para reduzir ainda mais o risco de lesões graves e morte devido a queda de móveis:

Coloque os objetos mais pesados nas gavetas mais baixas.

Não coloque televisões ou outros objetos pesados em cima deste artigo.

Nunca permita que as crianças trepem ou se pendurem nas gavetas, portas ou prateleiras.

Leia e siga cuidadosamente as instruções.

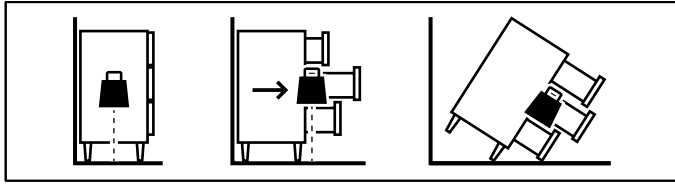

Româna

AVERTISMENT!

Răsturnarea pieselor de mobilier poate provoca răniiri grave sau fatale. Pentru a reduce riscul răsturnării mobilierului:

Fixează ÎNTOTDEAUNA mobilierul de perete cu dispozitivele anti-răsturnare potrivite.

Pentru a reduce riscul de accidente grave și decese provocate de răsturnare:

Așază obiectele grele în sertarul inferior.

Nu așeza televizorul sau alte obiecte grele deasupra piesei de mobilier.

Nu lăsa copiii să se urce pe piesele de mobilier sau să se agațe de sertare, uși sau police.

Citește instrucțiunile și urmează cu atenție fiecare pas.

Slovensky

UPOZORNENIE!

Pri prevrátení nábytku hrozí vážne až smrteľné poranenie. Aby ste znížili riziko prevrátenia:

Nábytok ZA KAŽDÝCH OKOLNOSTÍ do steny uktovite.

S cieľom eliminovať riziko vážneho poranenia či úmrtia v dôsledku prevrátenia nábytku, dbajte na nasledujúce zásady:

Umiestňujte ťažšie predmety do spodnej zásuvky. Televízor a iné ťažké veci nedávajte na vrch.

Nedovoľte deťom šplhať a vešať sa na skrinky, dvierka, alebo police.

Pozorne si prečítajte a dodržiavajte každý krok.

Български

ПРЕДУПРЕЖДЕНИЕ!

Сериозни или фатални инциденти могат да бъдат предизвикани от преобръщането на мебелите. За да намалите риска от преобръщане на мебели:

ВИНАГИ закрепвайте тези мебели към стената, като използвате обезопасителни скоби.

За да намалите риска от сериозни наранявания и фатални инциденти при преобръщане:

Поставяйте тежките вещи в най-долните чекмеджета.

Не поставяйте телевизор или други тежки вещи върху продукта.

Никога не позволявайте на децата да се катерят или да се повисват на чекмеджета, врати или рафтове.

Прочетете и следвайте внимателно всяка стъпка от инструкциите.

Hrvatski

UPOZORENJE!

Ako se namještaj prevrne, može doći do ozbiljnih ili smrtonosnih ozljeda. Kako bi se smanjila opasnost od prevrtanja namještaja:

Potrebno je UVIJEK pričvrstiti namještaj na zid koristeći sredstva za pričvršćivanje.

Za smanjenje rizika od ozbiljnih ili smrtonosnih ozljeda zbog prevrtanja:

Najteže predmete staviti u donju ladicu.

Ne postavljati TV ili druge teške predmete na ovaj proizvod.

Ne dopustiti djeci da se penju na ladice, vrata i police ili vješaju o njih.

Pažljivo pročitati i slijediti svaki korak upute.

Ελληνικά

Προειδοποίηση!

Σοβαροί ή μοιραίοι τραυματισμοί μπορεί να συμβούν από την ανατροπή επίπλου. Για να μειώσετε τον κίνδυνο ανατροπής του επίπλου:

ΠΑΝΤΑ να ασφαρίζετε αυτό το έπιπλο στον τοίχο χρησιμοποιώντας τα εξαρτήματα στερέωσης.

Για να μειωθεί περαιτέρω ο κίνδυνος σοβαρού τραυματισμού και θανάτου από ανατροπές:

Τοποθετήστε τα πιο βαριά αντικείμενα στο πιο χαμηλό συρτάρι.

Μην τοποθετείτε τηλεοράσεις ή άλλα βαριά αντικείμενα πάνω από αυτό το προϊόν.

Ποτέ μην αφήνετε τα παιδιά να ανεβαίνουν ή να κρεμιούνται από τα συρτάρια, τις πόρτες, ή τα ράφια.

Διαβάστε και ακολουθήστε προσεκτικά κάθε βήμα της οδηγίας.

Українська

ЗАСТЕРЕЖЕННЯ:

Падіння меблів може призвести до важких або смертельних травм. Щоб зменшити ризик перекидання меблів:

ЗАВЖДИ надійно прикріплюйте ці меблі до стіни, використовуючи відповідні кріплення.

Для подальшого зменшення ризику отримання важких і смертельних травм від падіння меблів:

Розмістіть найважчі речі у нижній шухляді.

Не ставте телевизор або інші важкі речі на ці меблі.

Ніколи не дозволяйте дітям залазити на шухляди, дверцята чи полиці або виснути на них.

Уважно прочитайте та дотримуйтесь інструкцій.

Srpski

UPOZORENJE!

Prevrtanje nameštaja može da izazove nastanak ozbiljnih ili fatalnih povreda. Da se umanjí opasnost od prevrtanja nameštaja:

UVEK pričvrsti ovaj nameštaj za zid zaštitom protiv prevrtanja.

Da dodatno smanjiš opasnost od teških povreda ili smrti od prevrtanja:

Najteže stvari stavi u donju fioku.

Ne postavljaj TV i druge teške predmete na vrh ovog proizvoda.

Ne daj deci da se penju ili kače na fioke, vrata ili police.

Pažljivo pročitaj ova uputstva i pridržavaj ih se.

Slovenščina

OPOZORILO!

Prevrnitev pohištva lahko privede do hudih telesnih poškodb ali smrti. Da zmanjšaš nevarnost prevrnitve pohištva:

VEDNO pritrđi ta kos pohištva na steno z varovali proti prevrnitvi.

Za dodatno zmanjšanje možnosti resnih ali smrtnih poškodb zaradi prevrnitve pohištva:

Težji predmeti naj bodo shranjeni v spodnjem predalu.

Na ta izdelek ne postavljaj televizorja in ne odlagaj drugih težkih predmetov.

Otrokom prepriči, da bi plezali ali se obešali na predale, vrata ali police.

Pozorno preberi navodila in jih dosledno upoštevaj.

Türkçe

UYARI!

Mobilyaların devrilmesi sonucunda ezilemeye bağlı ciddi veya ölümcül yaralanmalar meydana gelebilir. Mobilyanın devrilme riskini azaltmak için:

Mobilyayı DAİMA devrilme önleyici aparat kullanılarak duvara sabitleyiniz.

Ayrıca ciddi yaralanma riskini azaltmak için ipuçları:

Ağır nesnelere alt çekmeceye yerleştiriniz.

Bu ürünün üstüne TV veya diğer ağır nesnelere koymayınız.

Çocukların çekmecelere, kapaklara veya raflara tırmanmasına ya da asılmasına izin vermeyiniz.

Talimatın her adımını dikkatle okuyunuz ve uygulayınız.

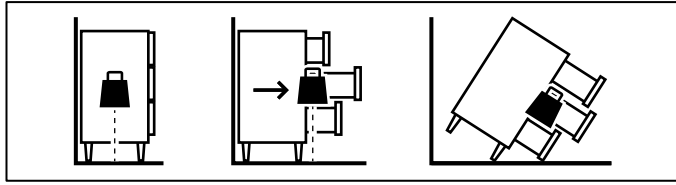

中文

安全警示!

家具傾倒可能导致严重或致命的伤害。为降低家具倾倒的风险:

请务必使用防翻倒约束装置,以便将家具固定在墙上。

为进一步降低家具翻倒而造成的重伤或死亡风险:

请将重物放在低层抽屉中。

请勿将电视机或其它重物放在该产品顶部。

请勿让儿童攀爬或悬挂在抽屉、柜门或搁板上。

请仔细阅读并按照说明中的每个步骤进行操作。

繁中

警告!

家具傾倒可能造成嚴重或致命的傷害。為降低家具傾倒的風險:

務必使用固定配件將此家具固定在牆上。

家具傾倒或會造成嚴重或致命的傷害:

請將重物放置在底層抽屜。

請勿將電視或其他重物放在此產品的上方。

切勿讓兒童攀爬或懸掛在抽屜、門板或層架上。

請仔細閱讀並依照說明書的步驟。

한국어

경고!

가구 전복 사고가 발생하면 심각한 부상을 입을 수 있습니다. 가구가 넘어질 위험을 줄이려면 다음과 같은 조치를 취하세요.

가구는 전복 사고 방지용 부품으로 벽에 반드시 고정하세요.

심각한 부상이나 사망에 이를 수 있는 가구 전복 방지를 위해서는 다음과 같이 하세요.

무거운 물건은 아래쪽 서랍에 보관하세요.

본 제품 위에 무거운 물건이나 TV를 두지 마세요.

아이들이 서랍이나 도어, 선반 등을 타고 오르거나 매달리지 않게 하세요.

지침의 각 단계를 자세히 읽고 따르세요.

日本語

警告!

家具の転倒により、家具の下敷きになって大ケガ、あるいは生命にかかわるような傷害を負う危険があります。家具の転倒のリスクを減らすために以下のことを守ってください。

転倒防止用固定具を用いて、必ず本製品を壁に固定してください。

家具の転倒による重大なケガや死亡事故を防ぐため、

重い物は下段の引き出しに入れてください。

本製品の上にテレビなどの重いものを置かないでください。

安全のため、引き出しや扉、棚の上によじ登ったり、ぶら下がったりしないよう、お子さまにご指導ください。

注意事項をよく読み、手順に従ってください。

Bahasa Indonesia

PERINGATAN

Cedera serius dapat terjadi akibat perabot terjatuh. Untuk mengurangi risiko furnitur terjatuh:

SELALU kencangkan perabot ke dinding dengan menggunakan alat pengencang.

Untuk mengurangi resiko cedera serius dan kematian akibat perabotan terjatuh:

Letakkan benda berat di laci paling bawah.

Jangan meletakkan TV atau benda berat di atas produk ini.

Jangan biarkan anak memanjat atau mengganduli laci, pintu dan rak.

Baca dan ikuti setiap langkah petunjuk dengan seksama.

Bahasa Malaysia

AMARAN!

Kecederaan serius atau maut boleh berlaku akibat perabot terbalik. Bagi mengurangkan risiko perabot terbalik:

SENTIASA kukuhkan perabot ini pada dinding menggunakan penahan rebah.

Bagi mengurangkan lagi risiko kecederaan serius dan kematian akibat terbalik:

Tempatkan barang paling berat di dalam laci paling bawah.

Jangan letakkan TV atau lain-lain objek berat di atas produk ini.

Jangan biarkan kanak-kanak memanjat atau bergayut pada laci, pintu, atau para-para.

Baca dan ikuti setiap langkah arahan dengan teliti.

عربي

تحذير!

مخاطر تعرّض لإصابات خطيرة نتيجة انقلاب الأثاث. للحد من خطر انقلاب الأثاث:

يجب تثبيت هذا الأثاث دائماً على الحائط بواسطة أدوات التثبيت.

لتقليل مخاطر الإصابة الخطيرة والتعرض للموت نتيجة انقلاب الأثاث:

يجب وضع الأشياء الثقيلة في الدرج السفلي.

لا يجب وضع تلفزيون أو أي أشياء ثقيلة أخرى فوق هذا المنتج.

يجب عدم السماح للأطفال بتسلق أو التعلق على الأدراج، الأبواب، أو الأرفف.

يرجى قراءة ومتابعة كل خطوة من التعليمات بدقة.

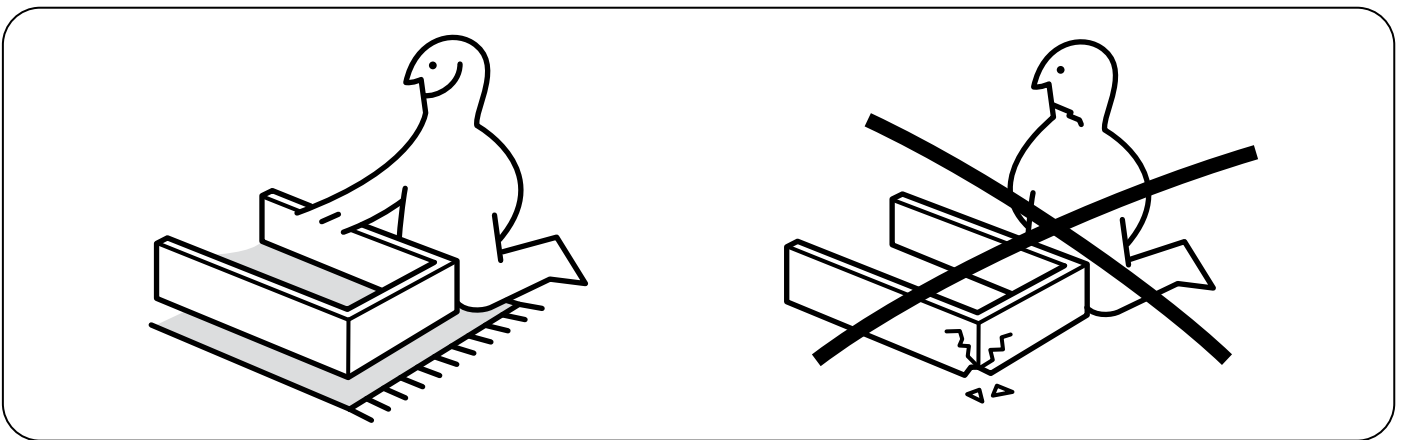
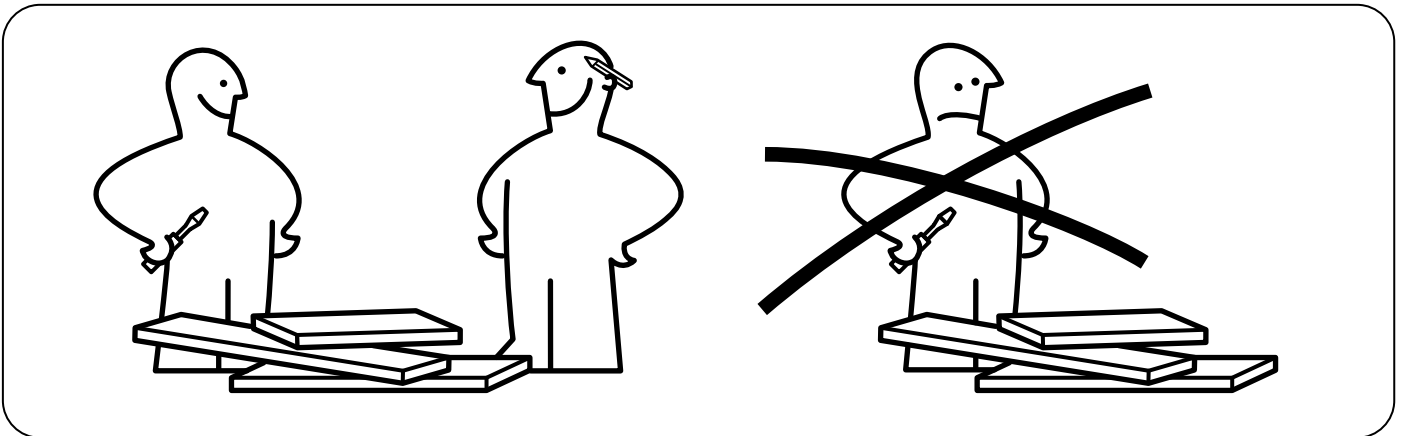
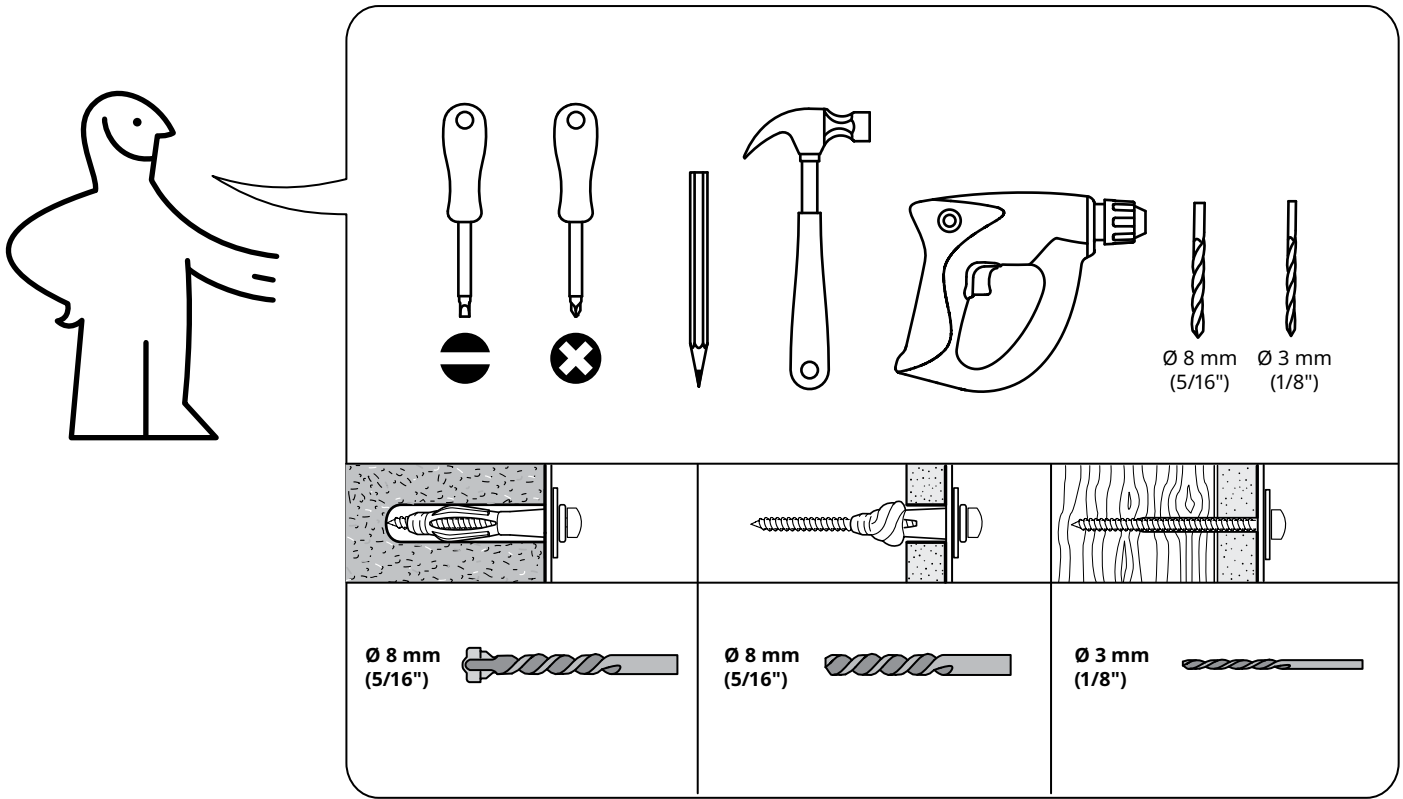

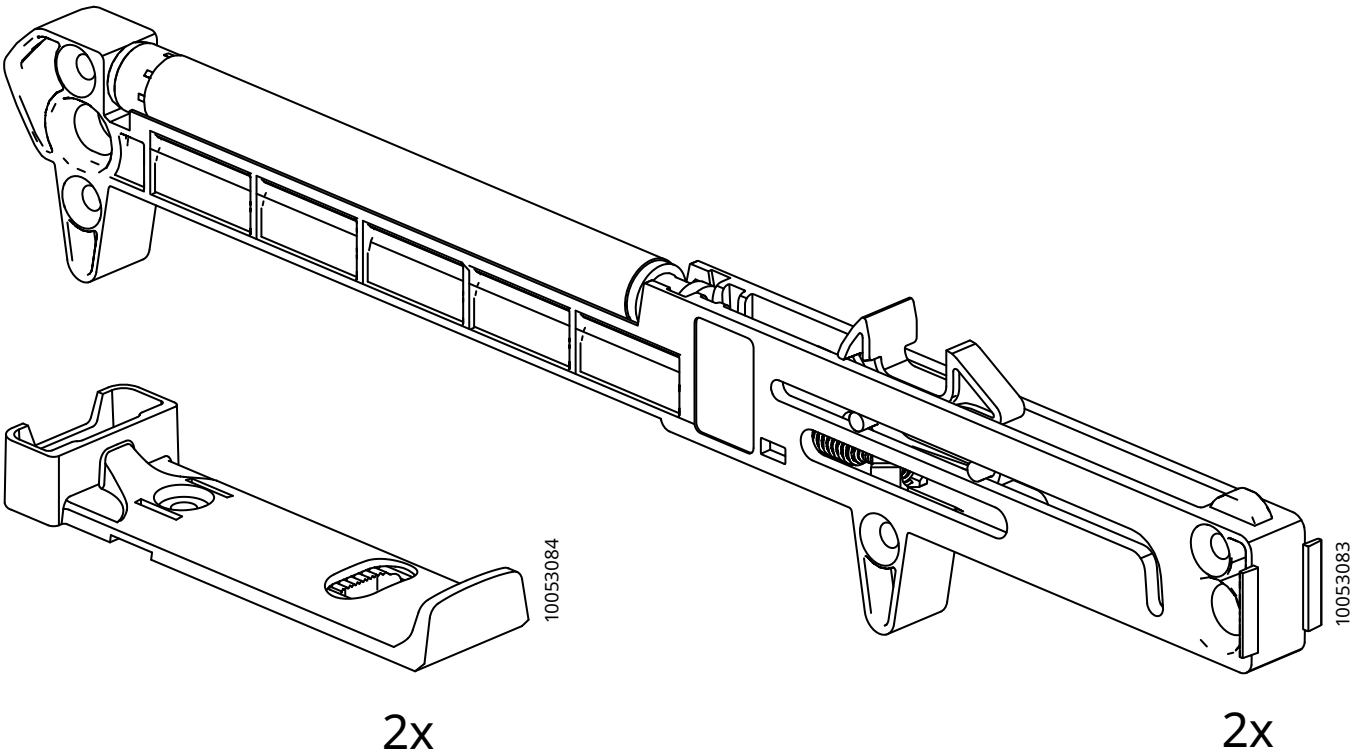
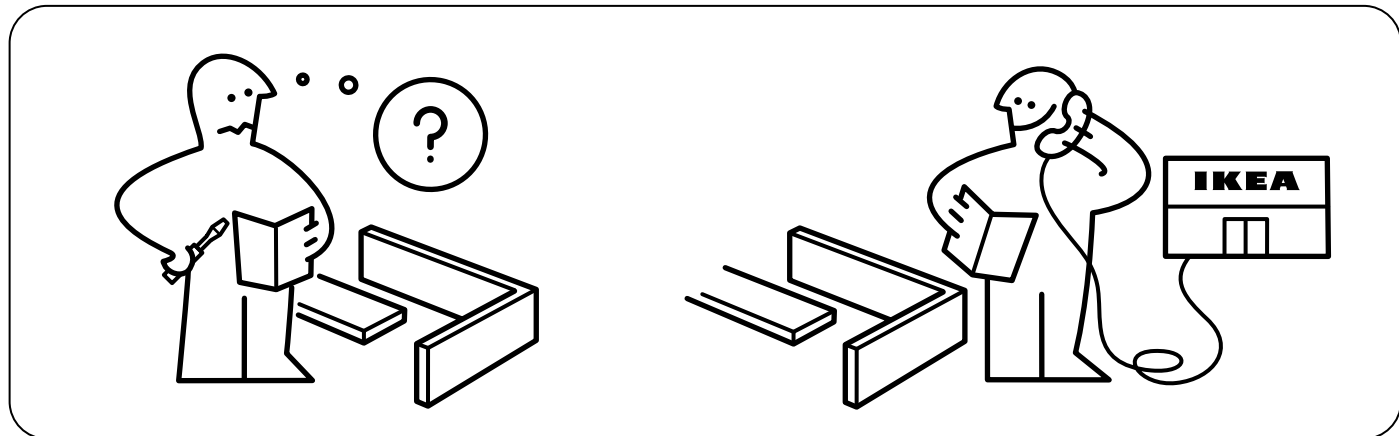
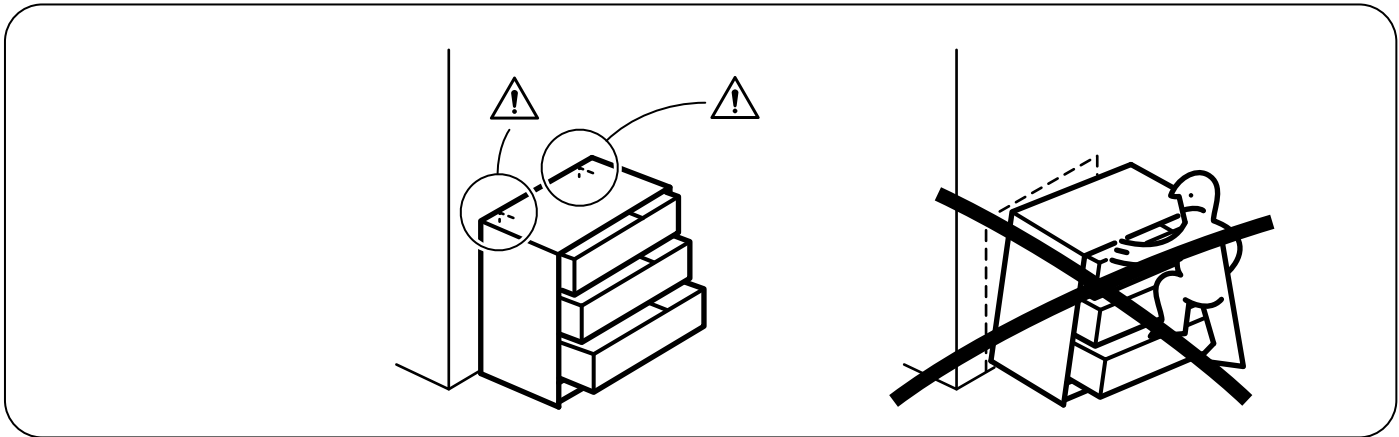

1



16x

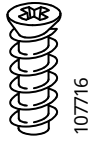

26x



4x

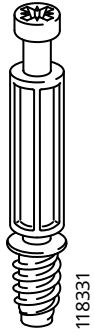

28x



4x

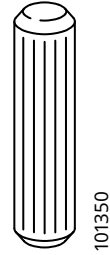

40x

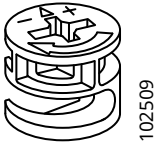

18x

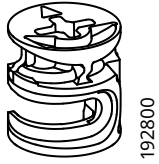

10x

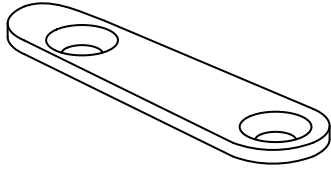

2x

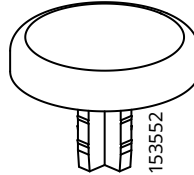

4x

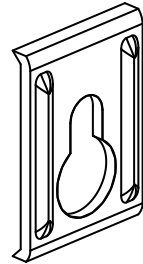

4x

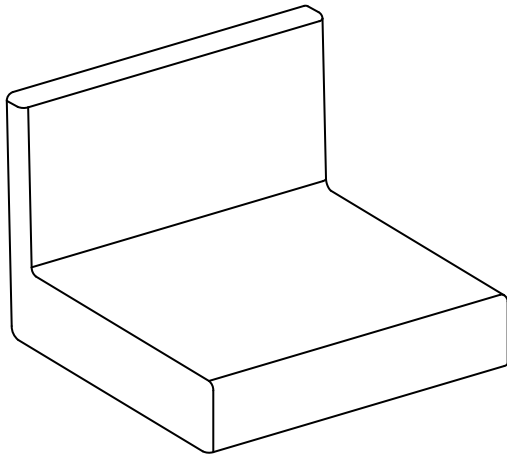

4x

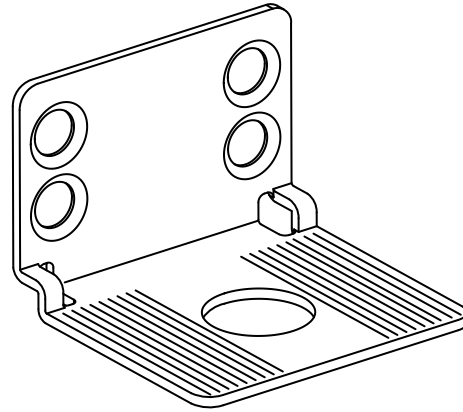

4x

2



100359

4x

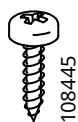

108445

4x



113928

18x

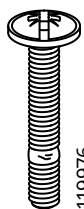

119976

2x

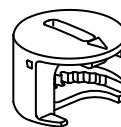

119030

25x

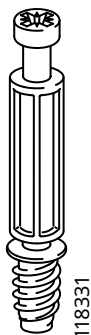

118331

17x



101341

20x

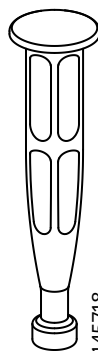

145718

8x

3



147968

2x

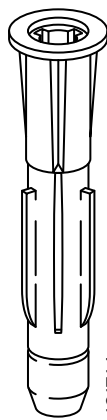

121714

2x

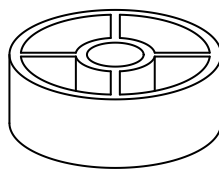

110646

2x

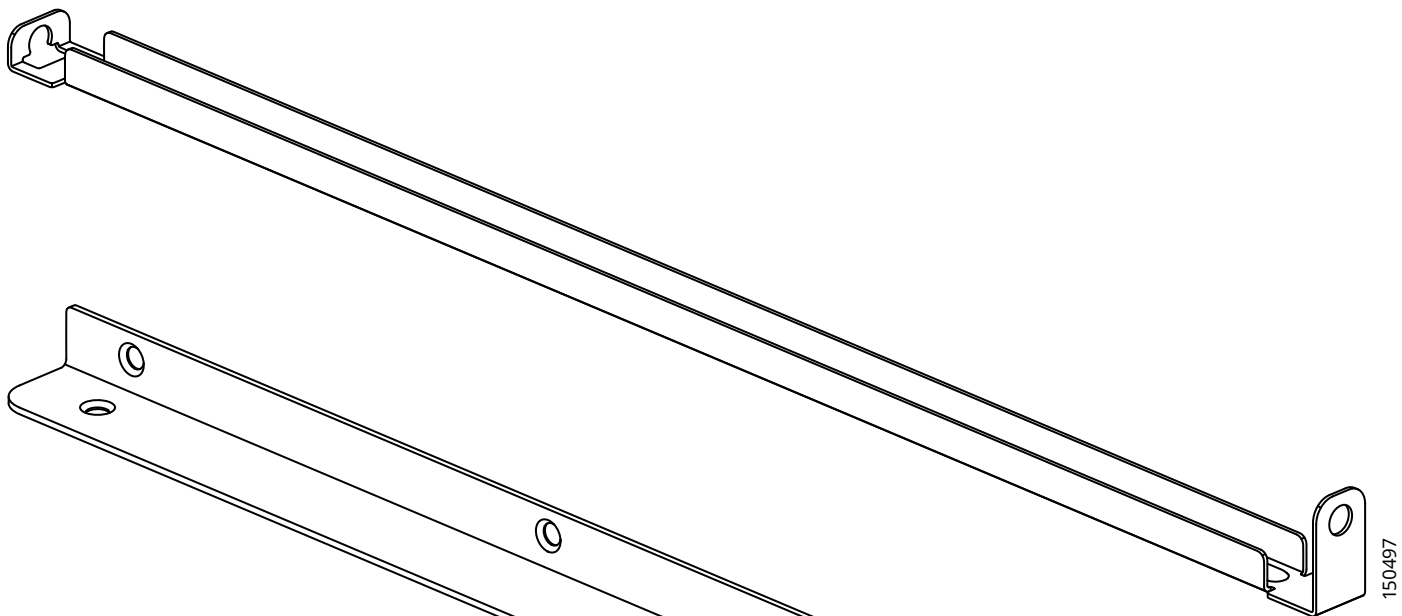

2x

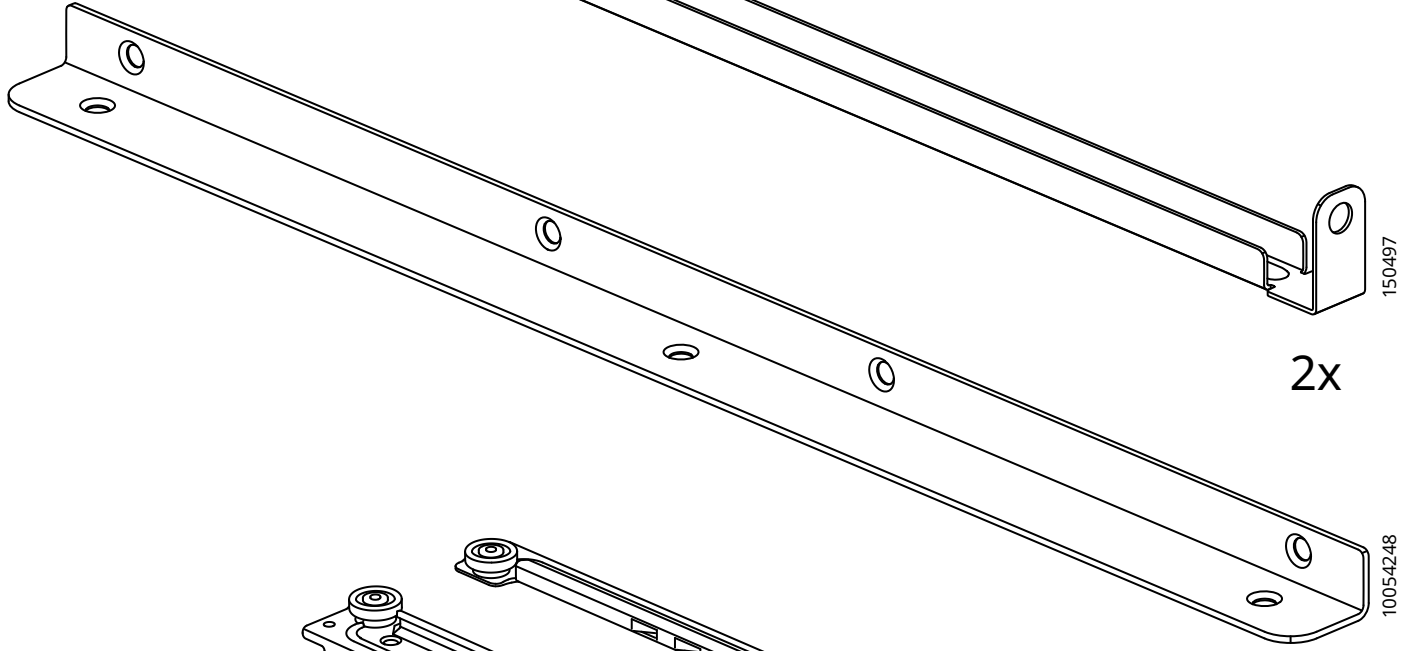

2x

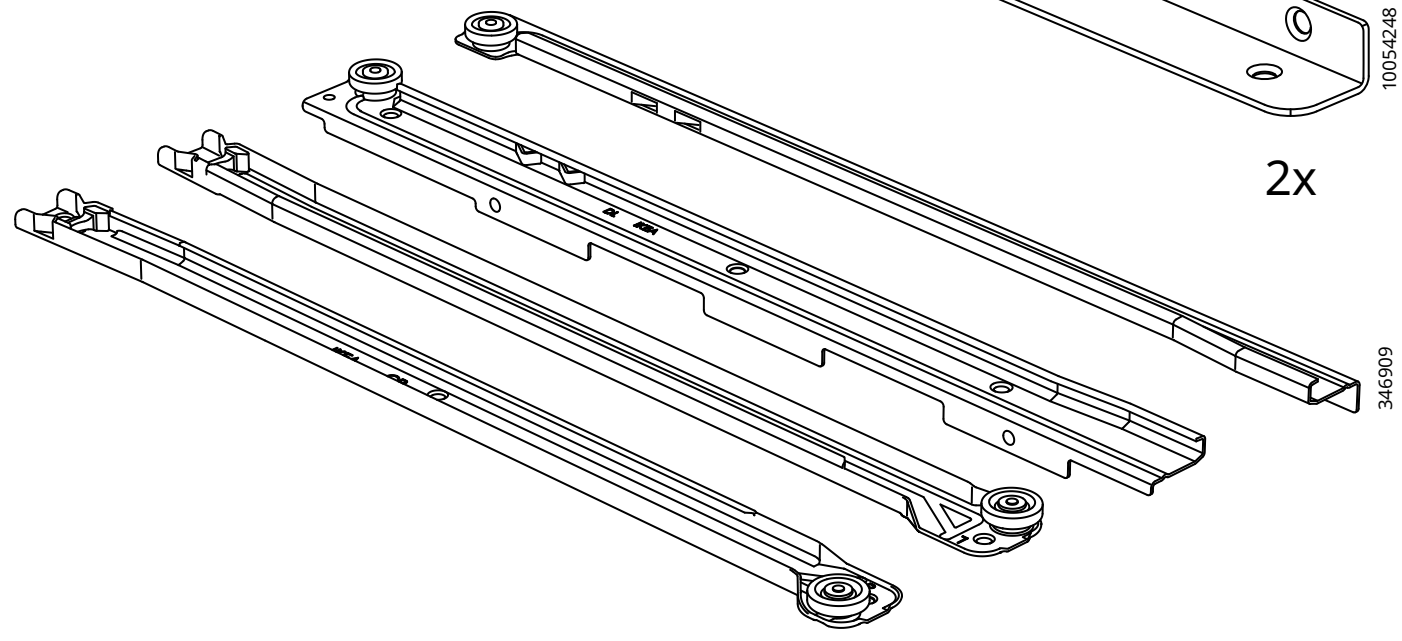

3x

1

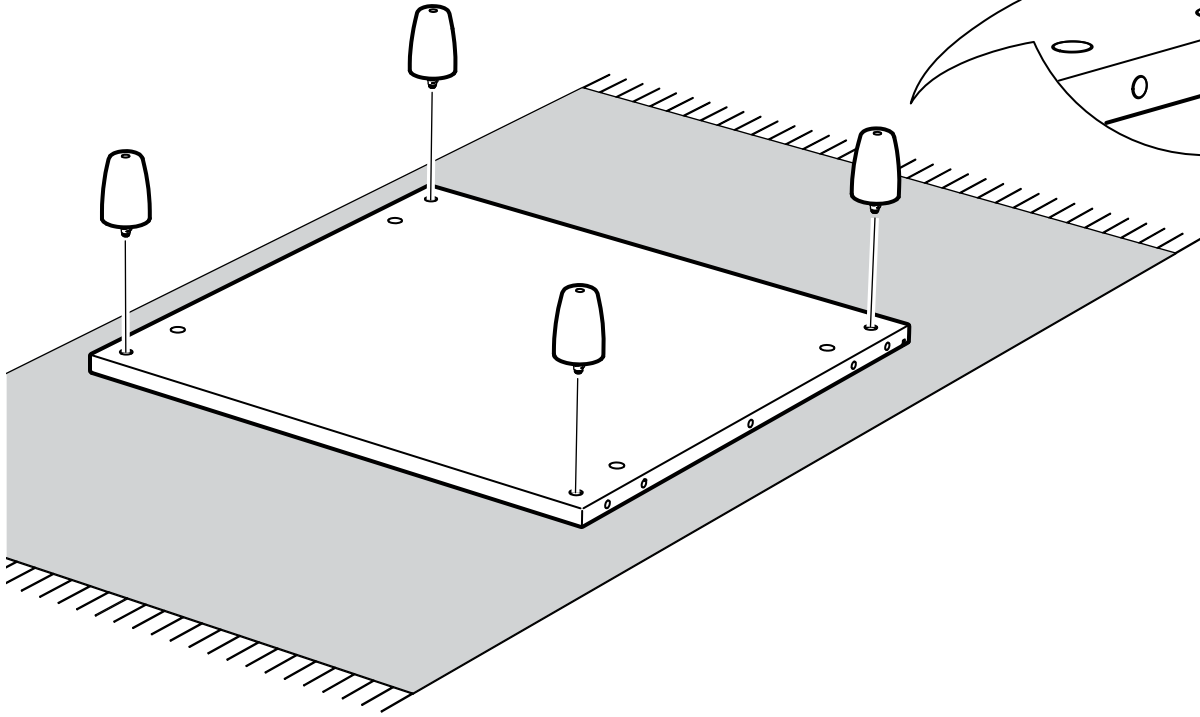
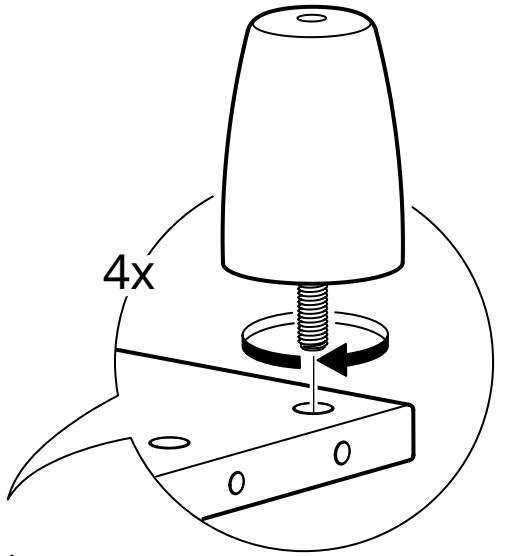

2

4X

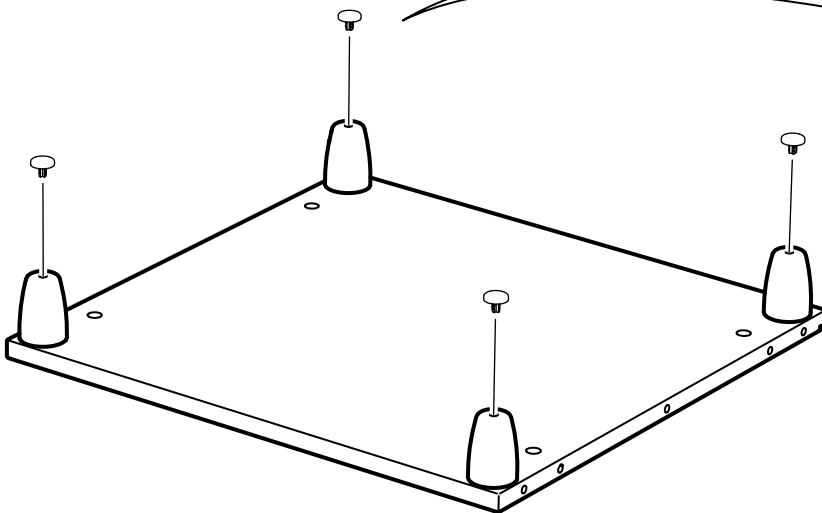
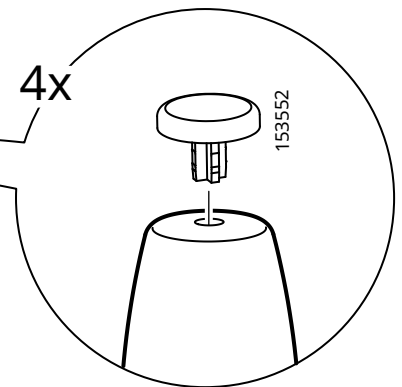

3

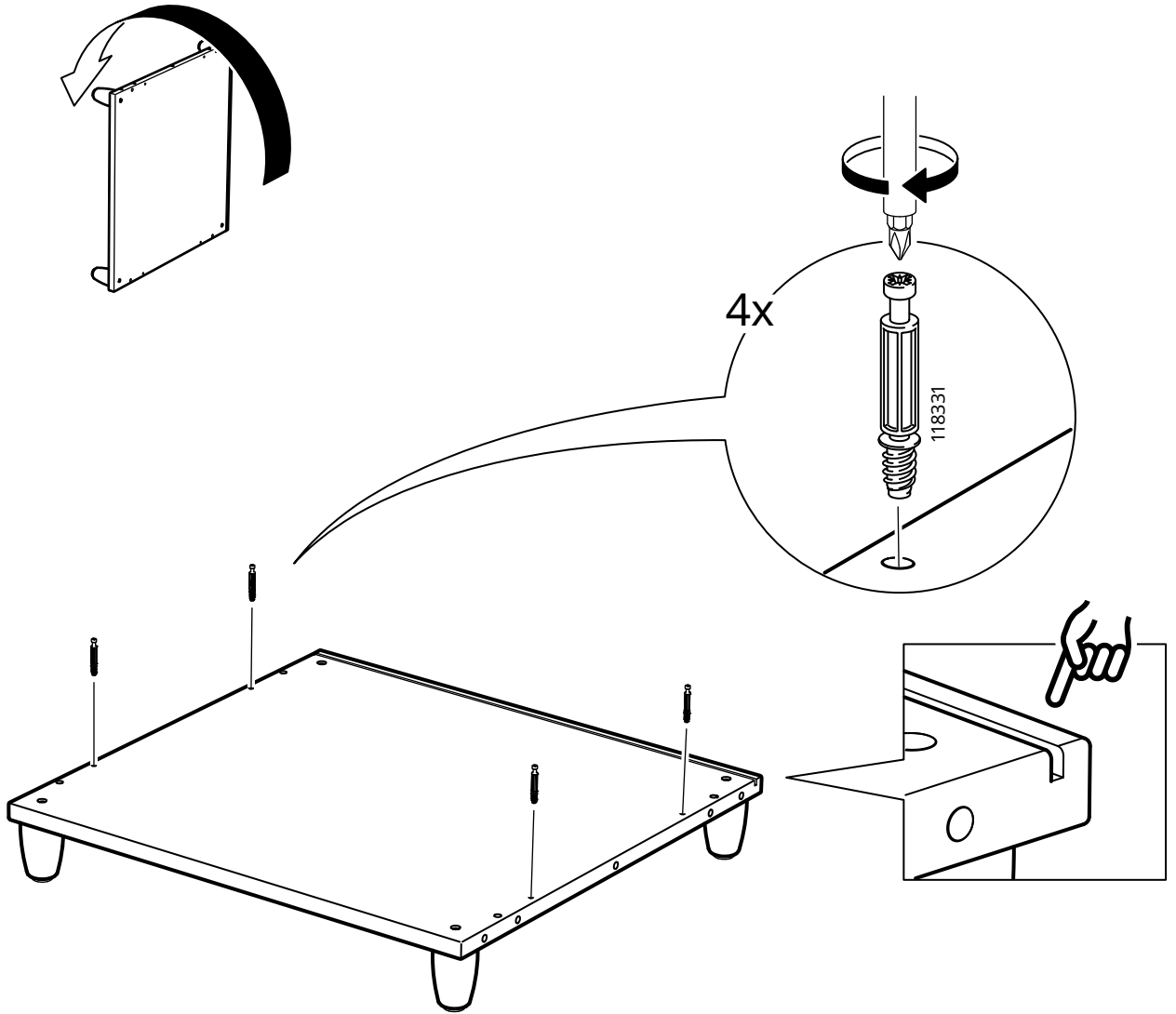

4

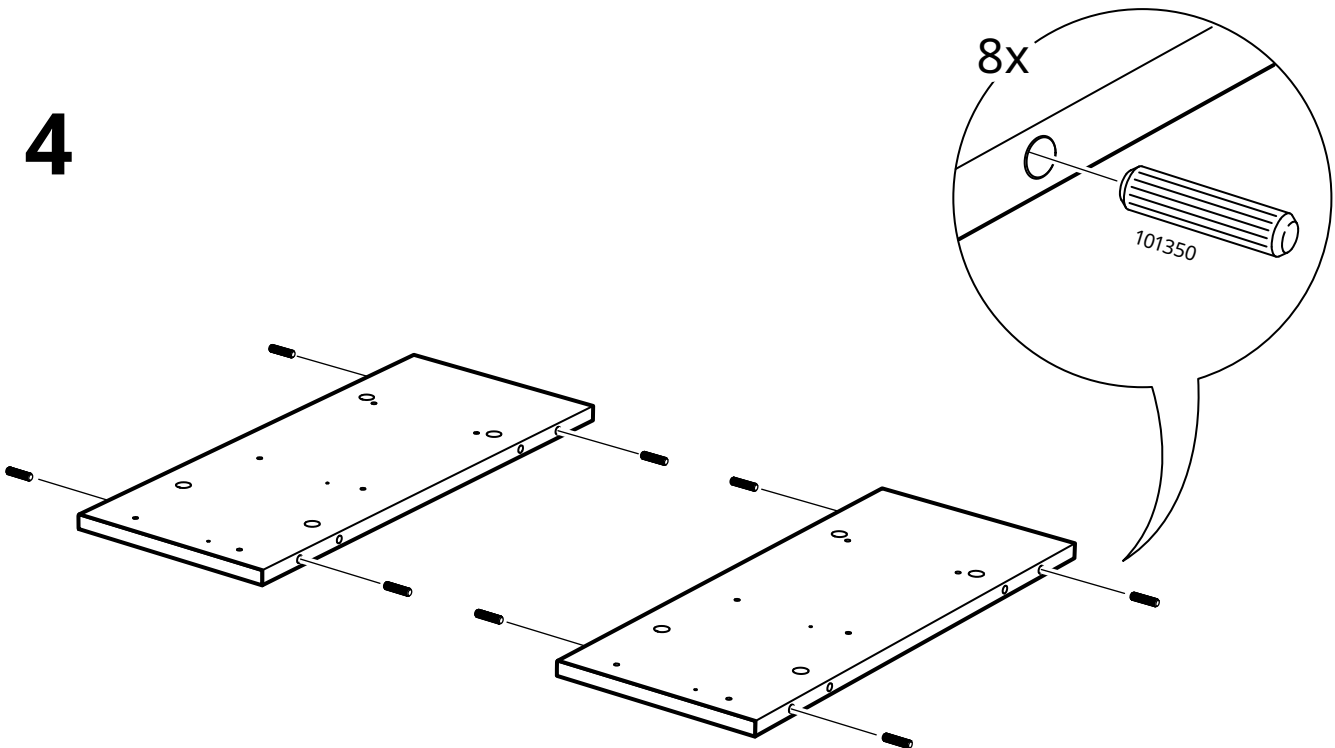

5

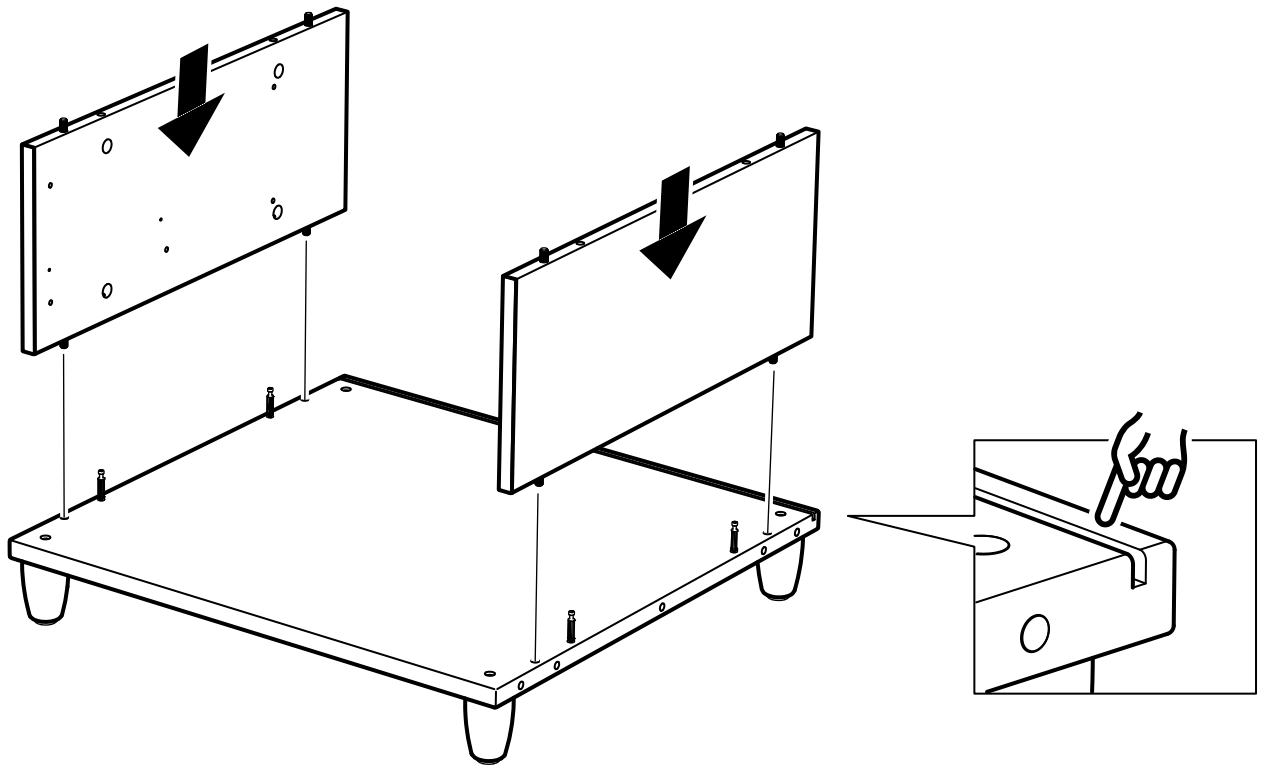

6

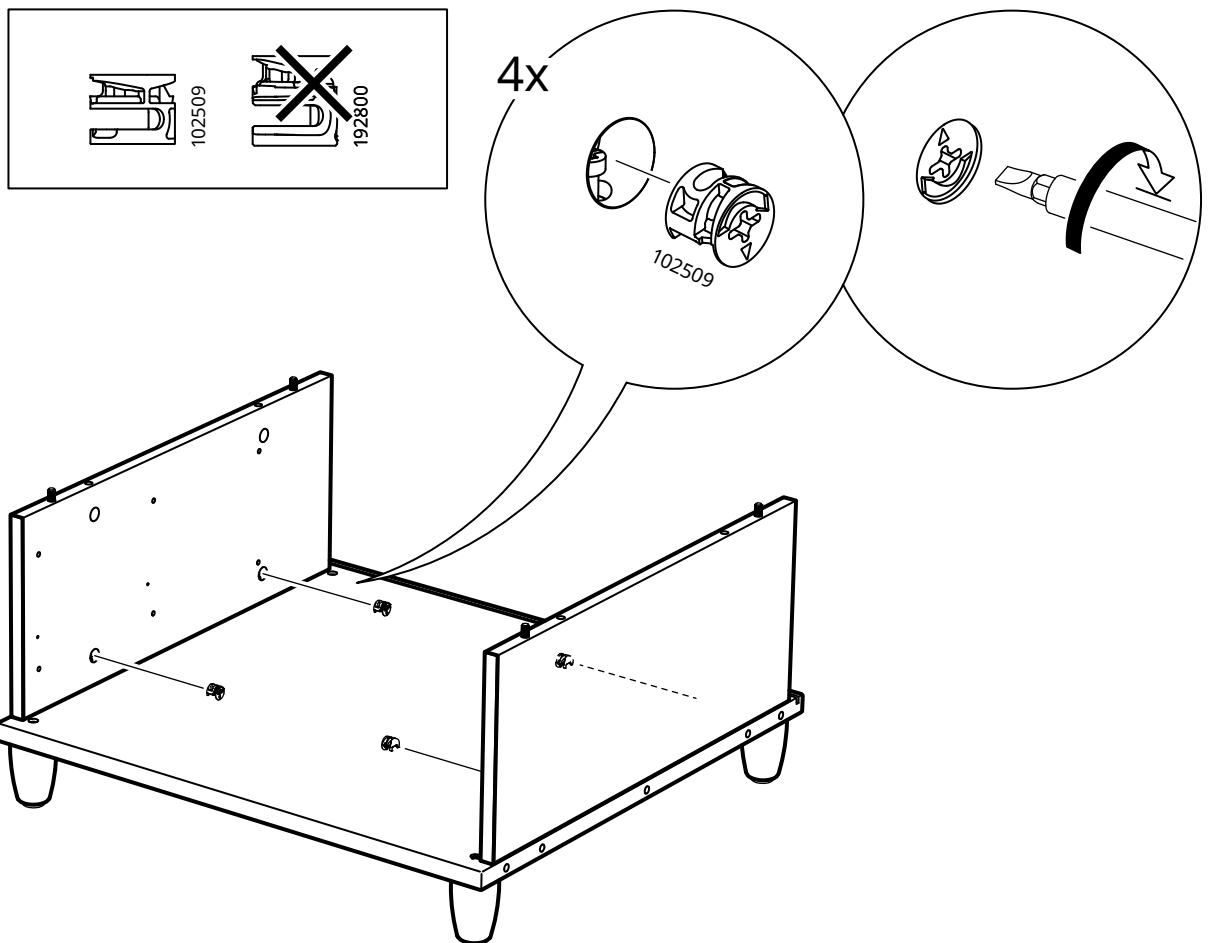

7

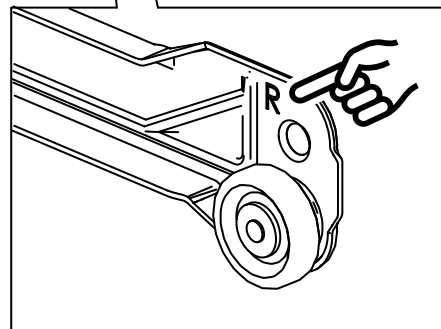
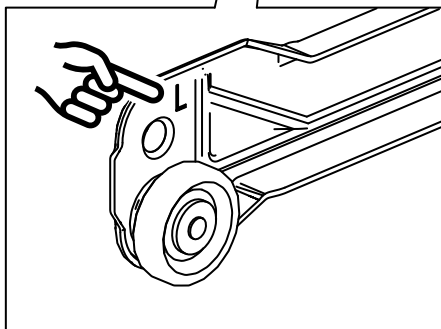
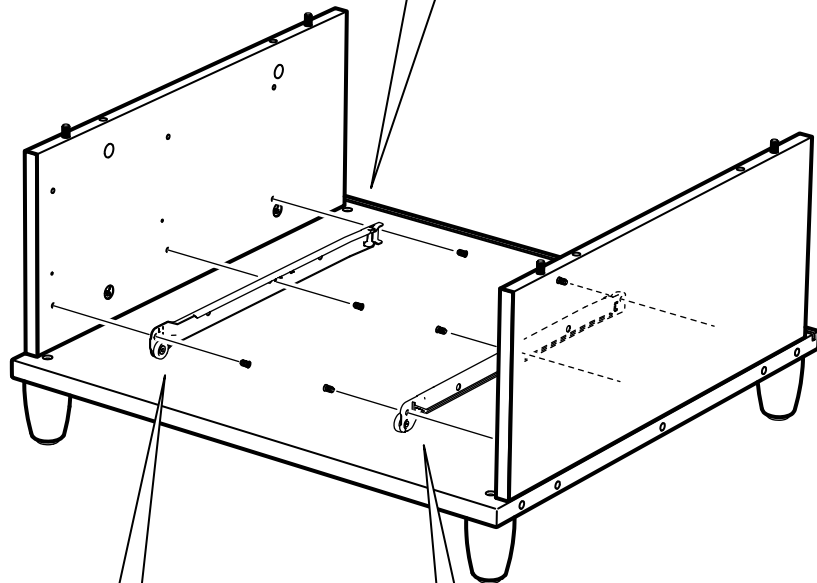
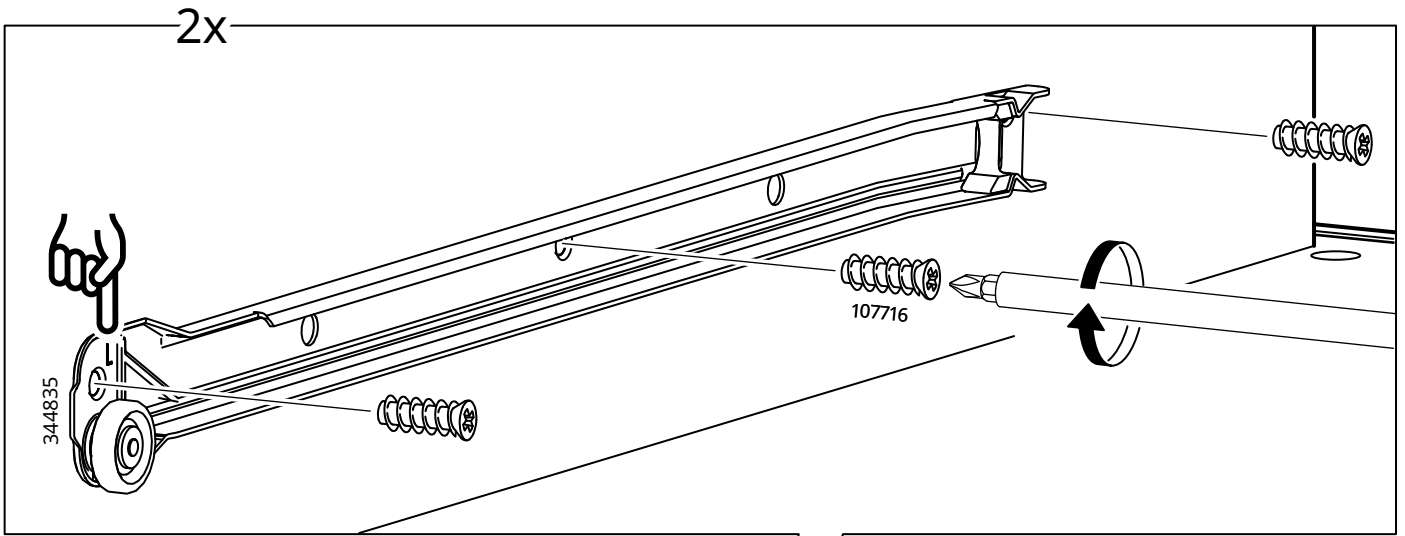

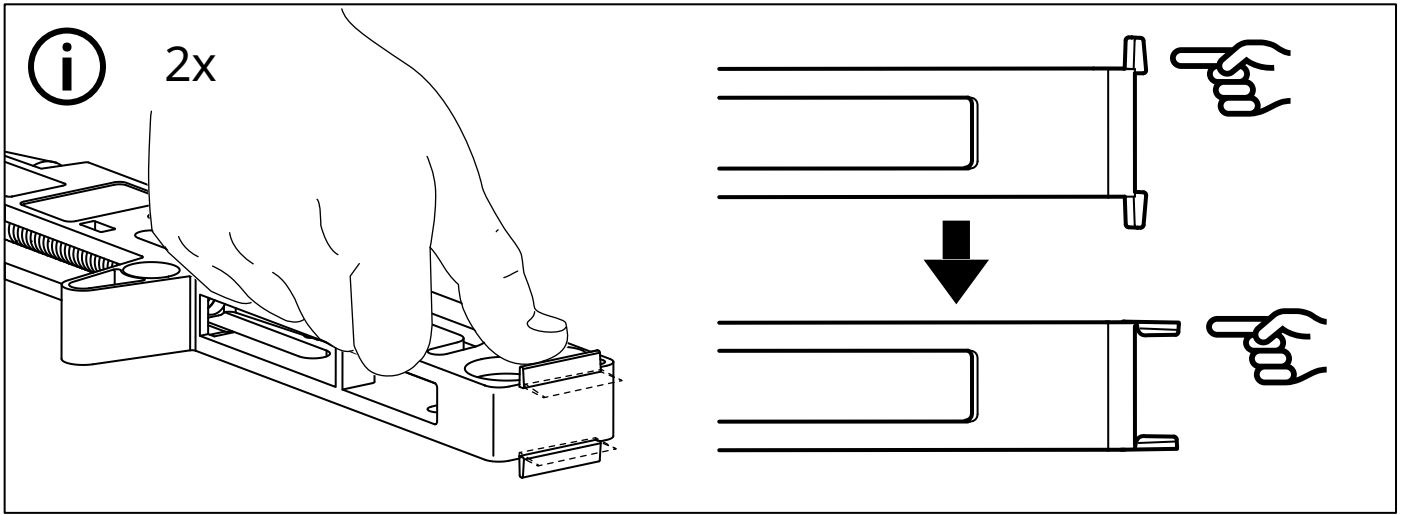

8

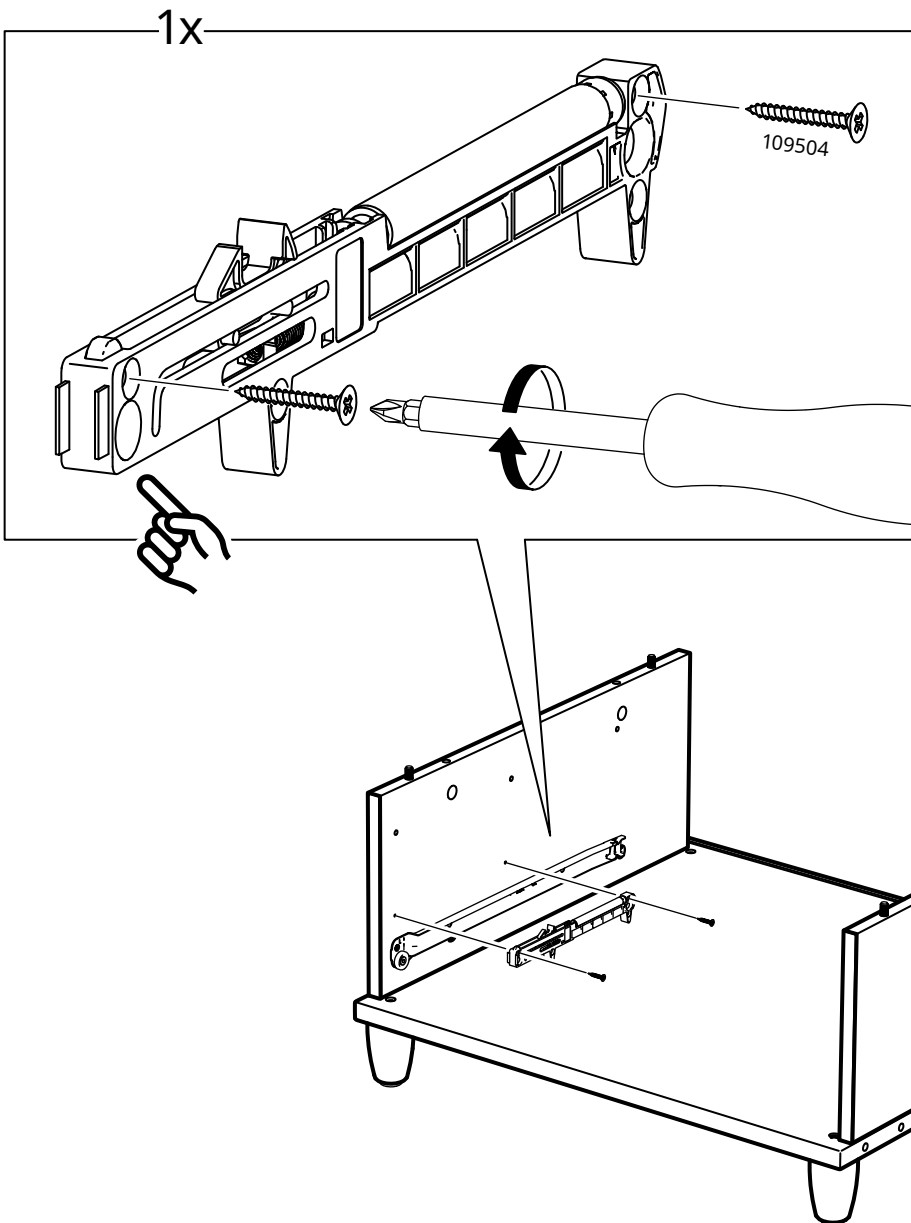

9

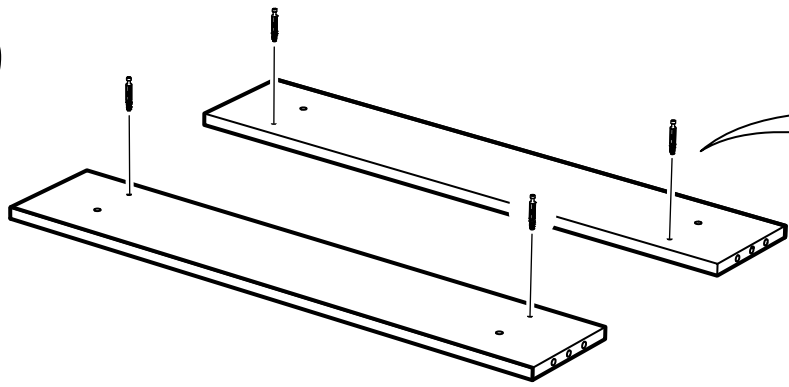

4x

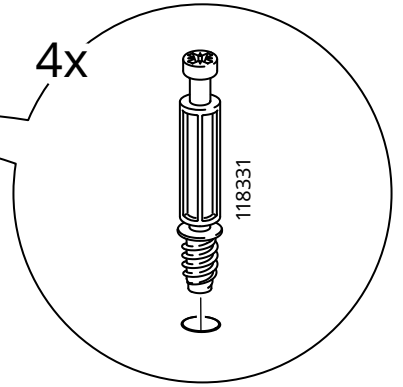

10

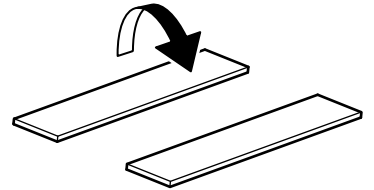
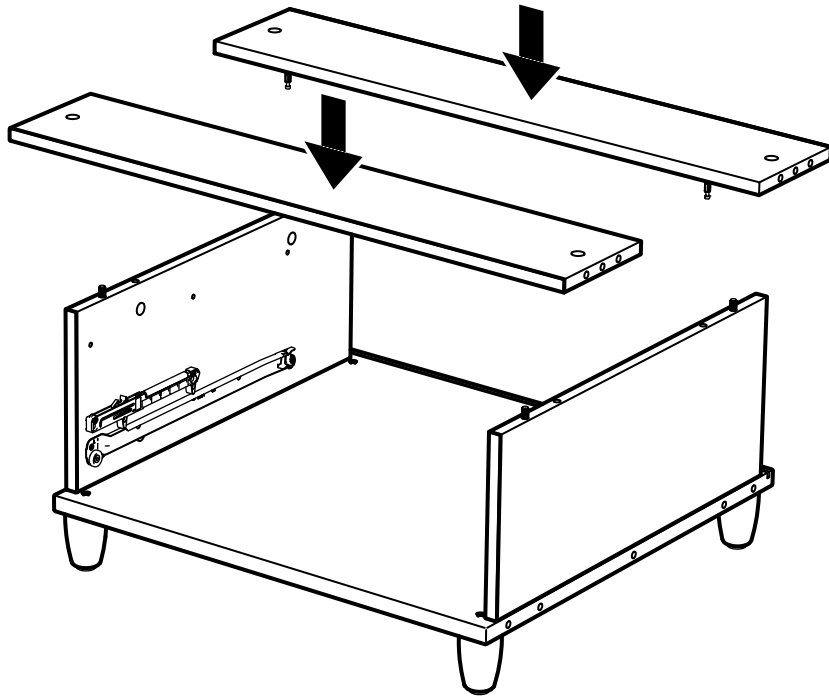

11

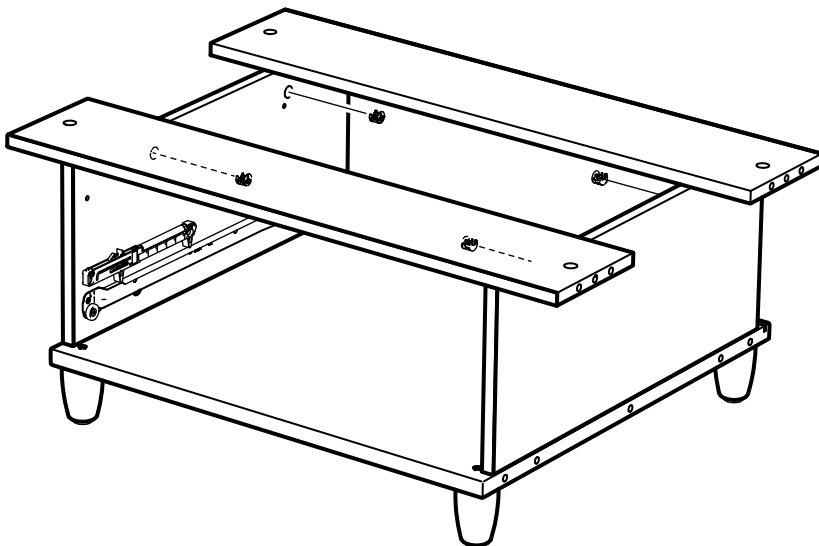

4x

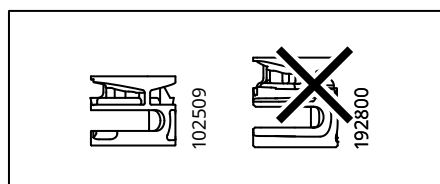
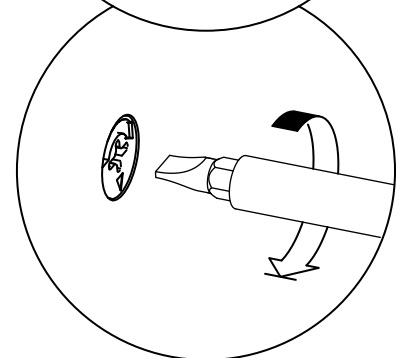
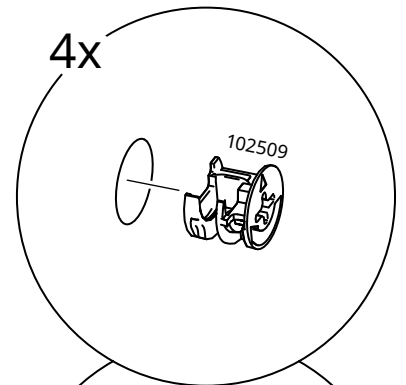

12

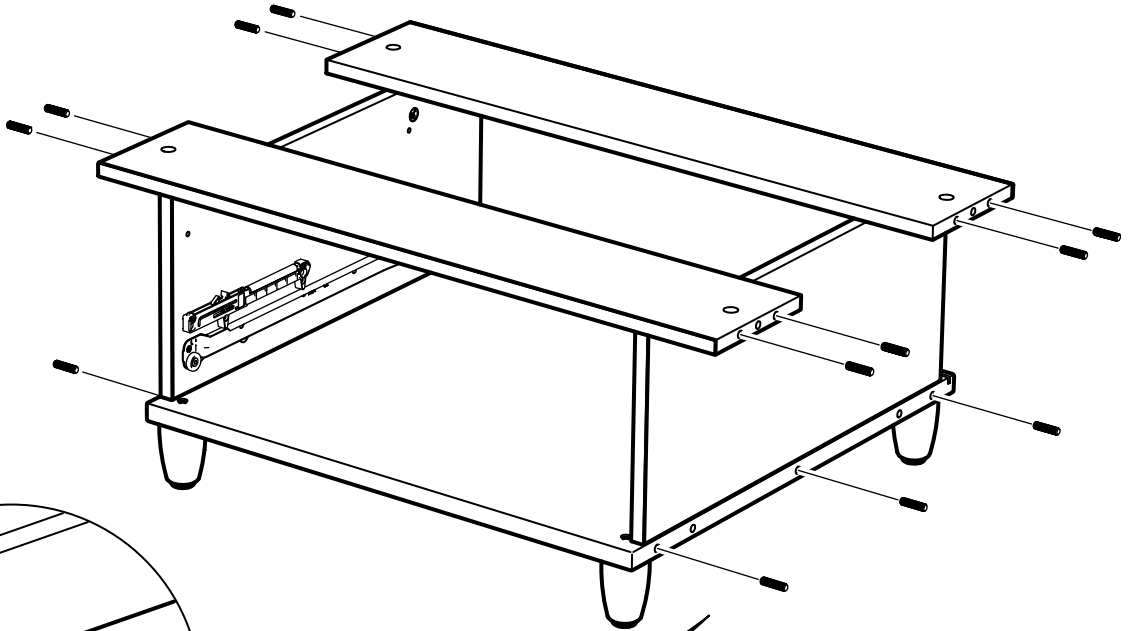

14x

101350

6x

118331

13

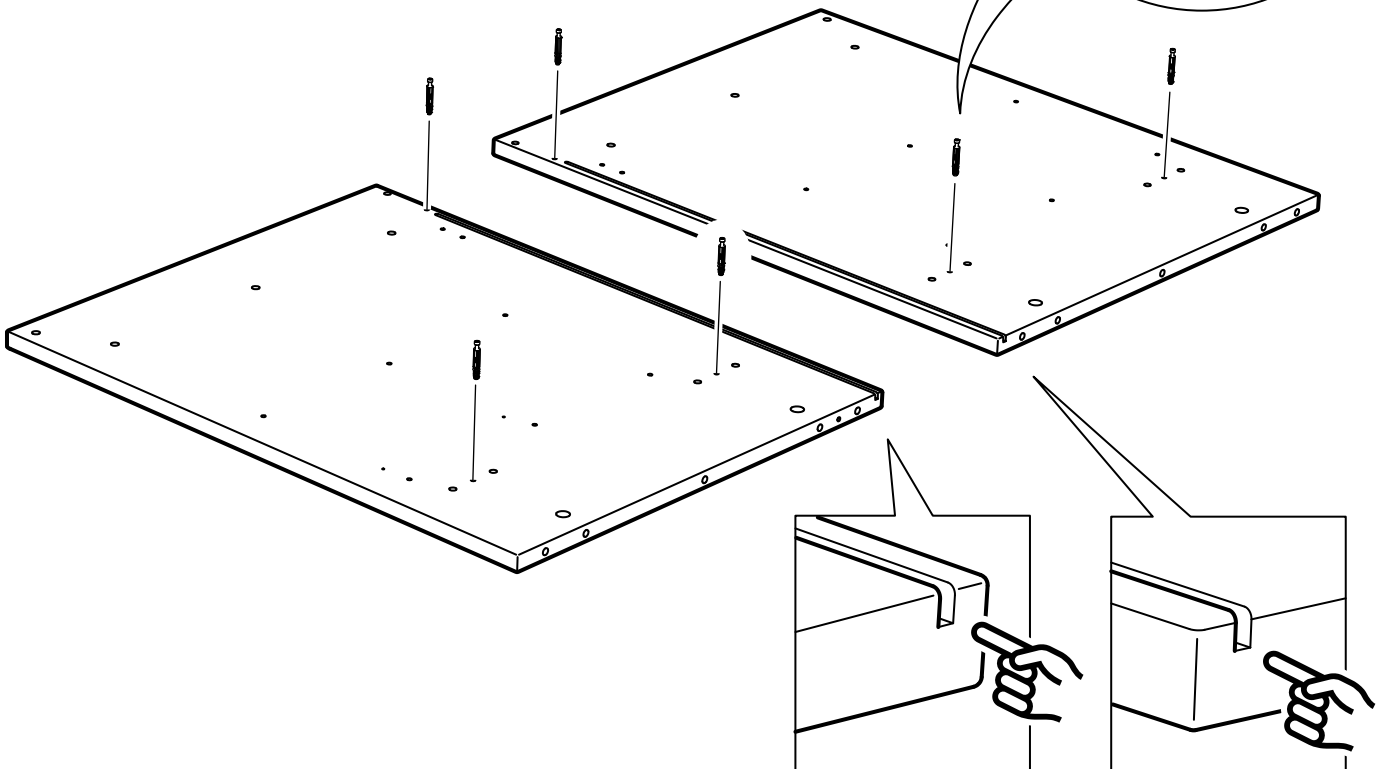

14

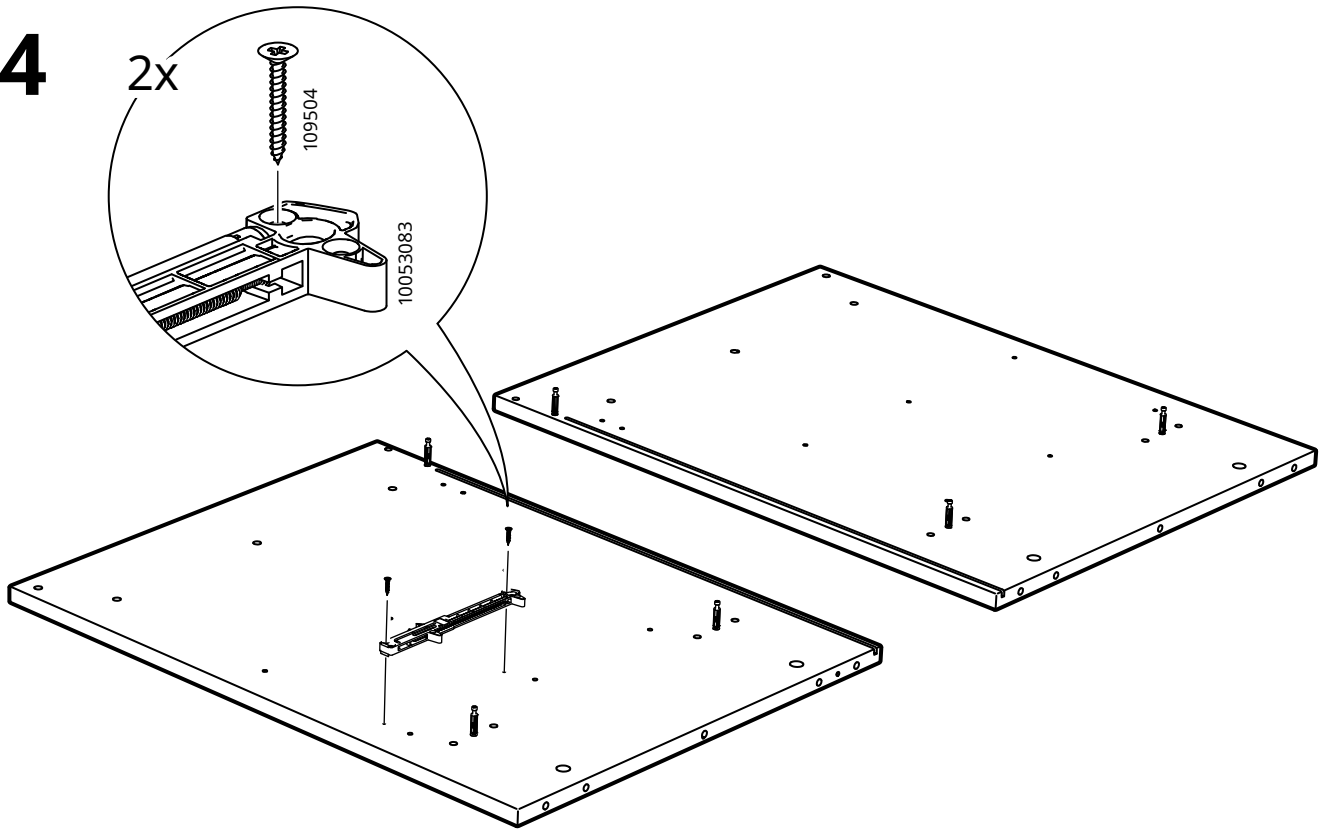

15

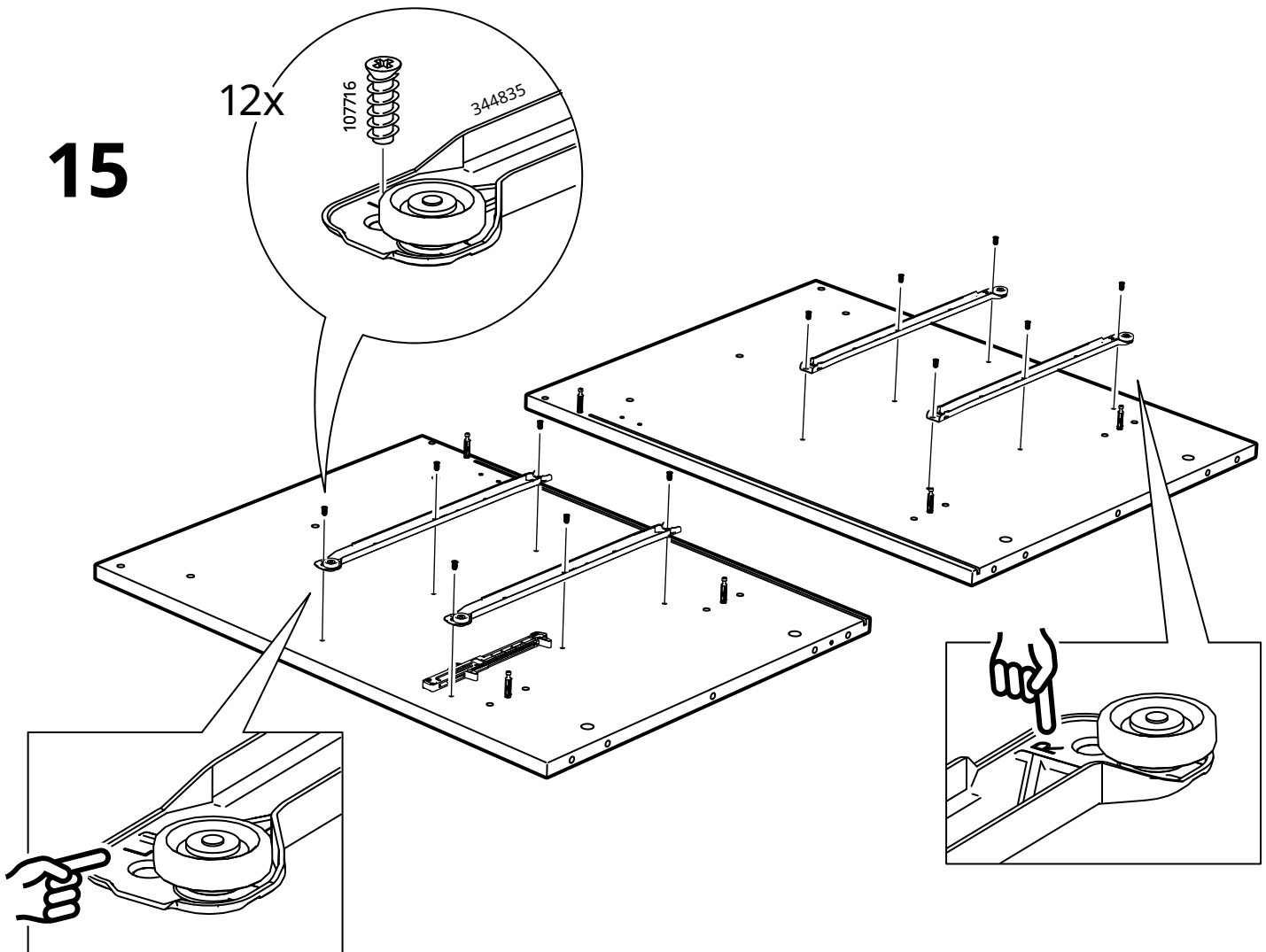

16

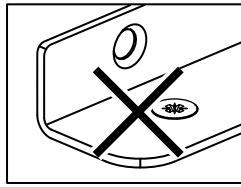
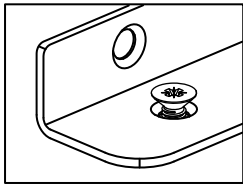

6x

10054248

100355

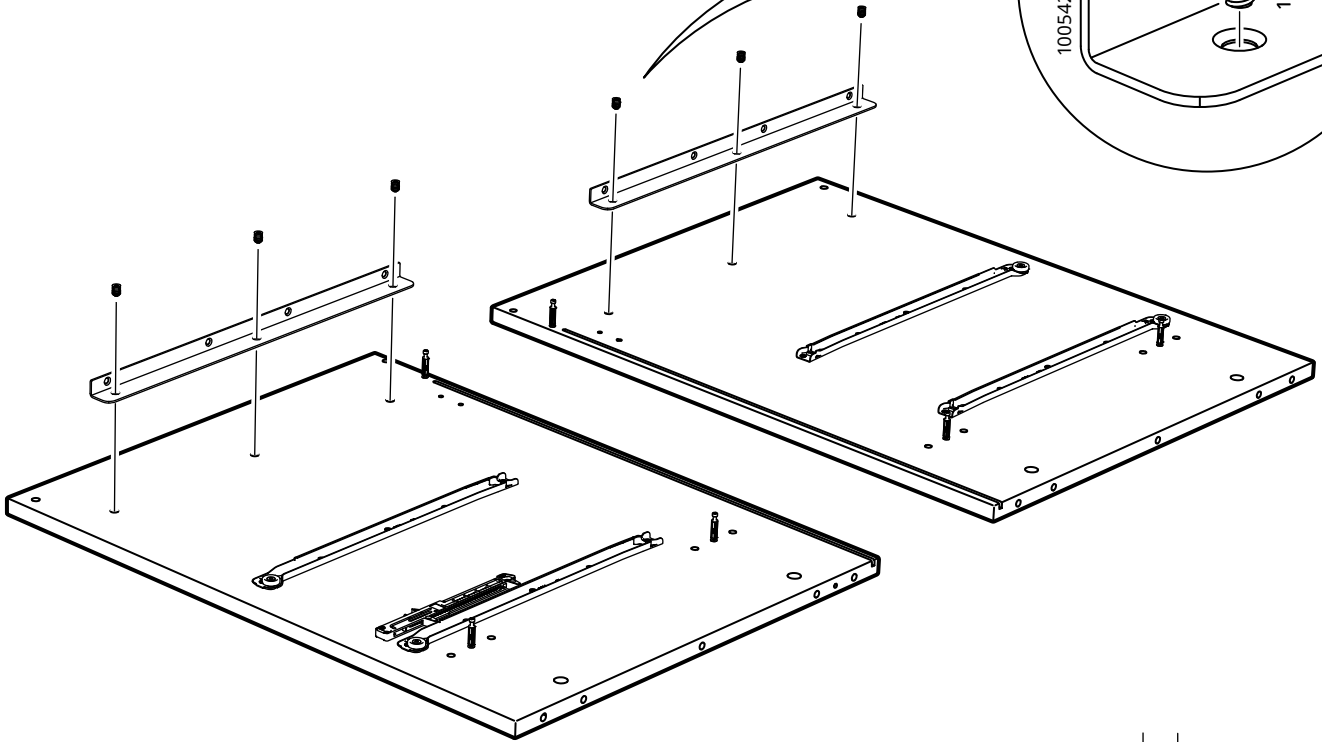

17

2x

107716

115753

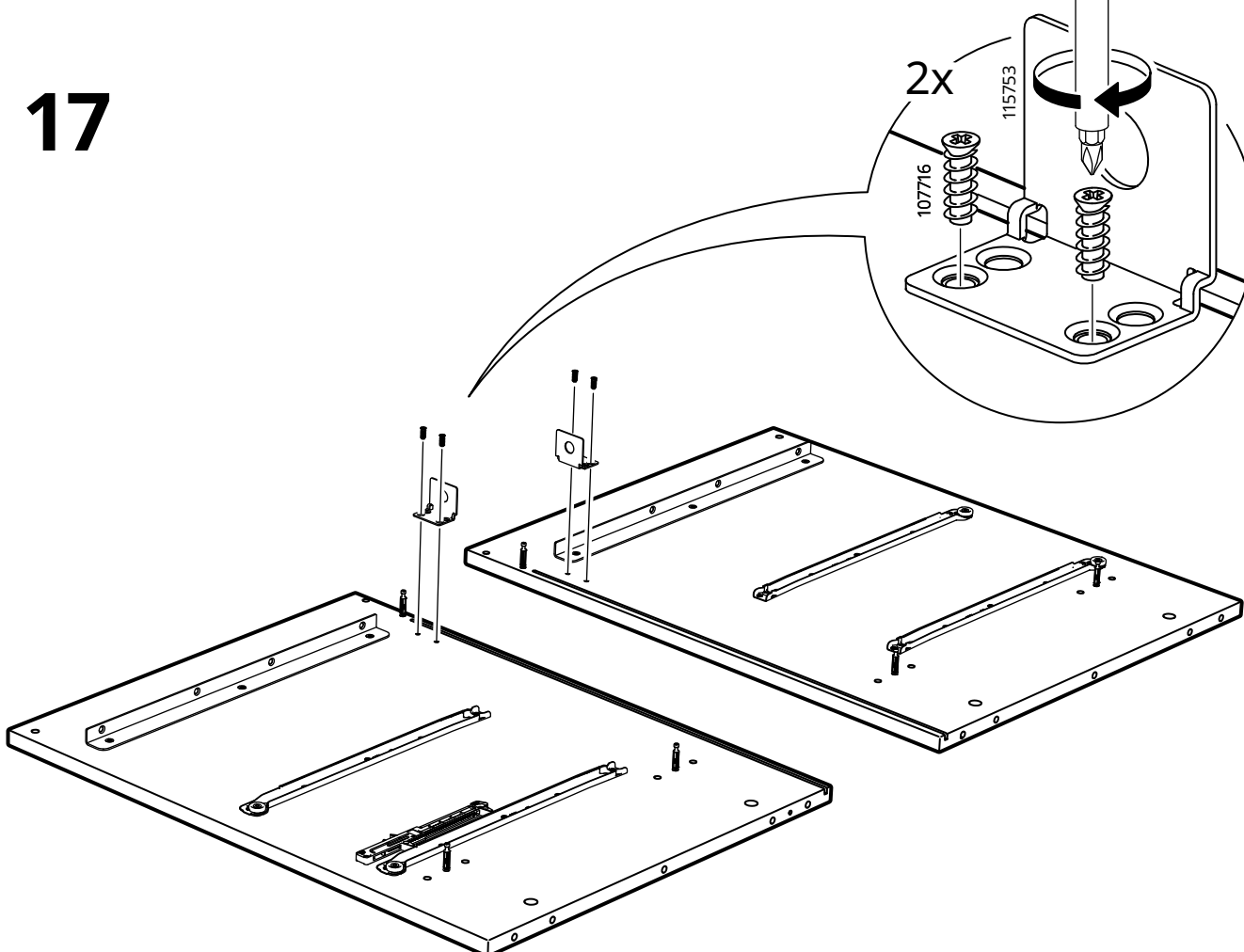

18

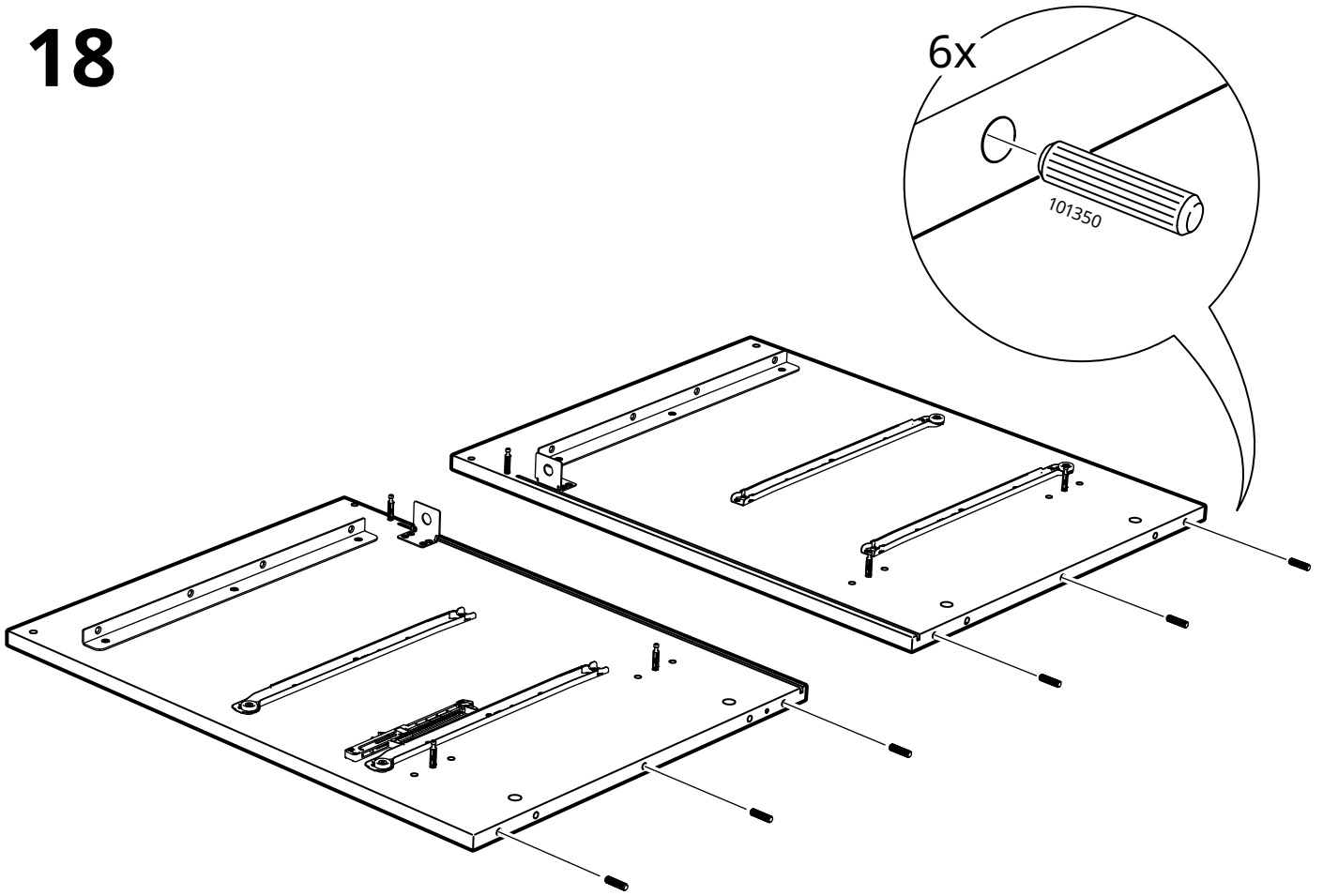

19

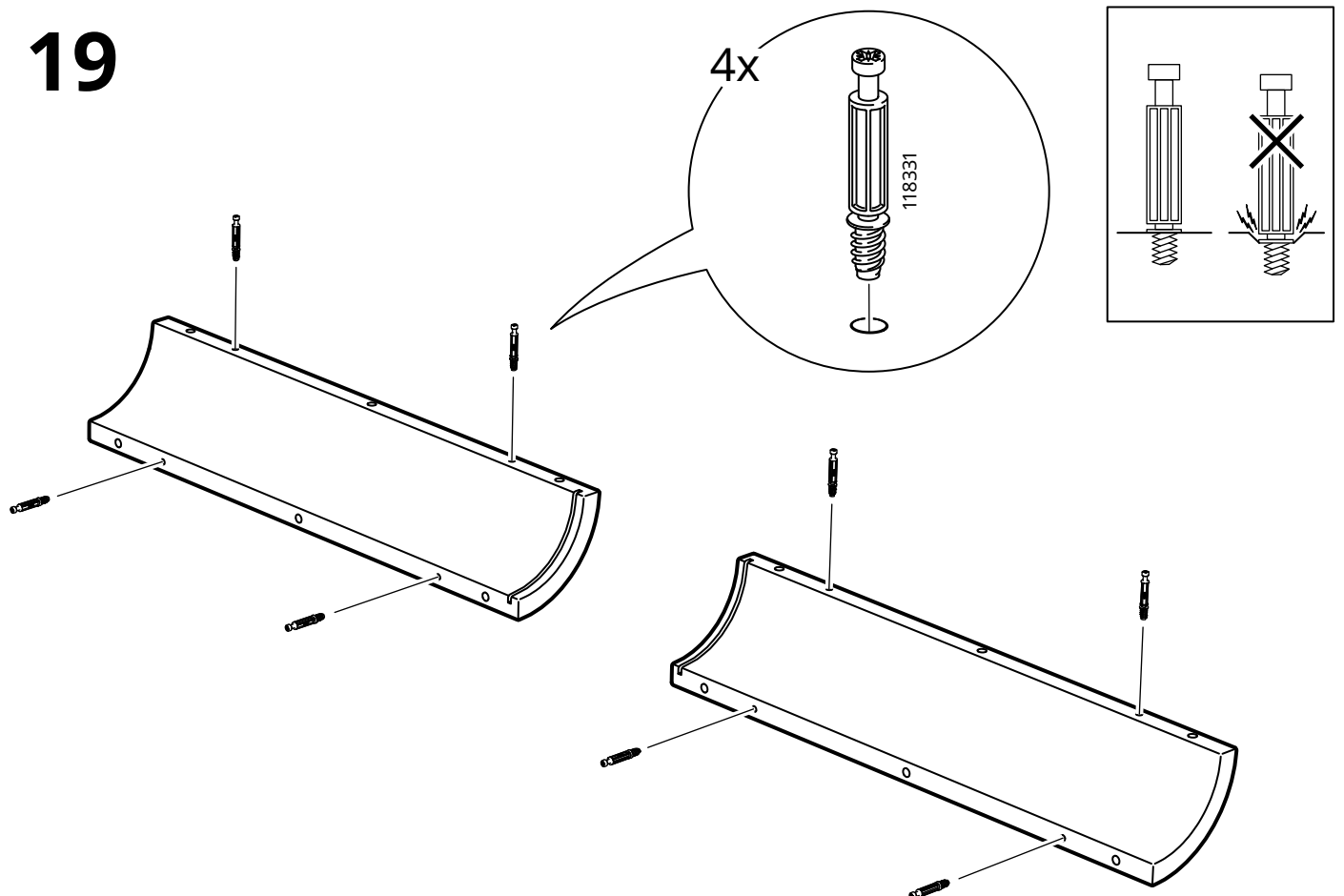

20

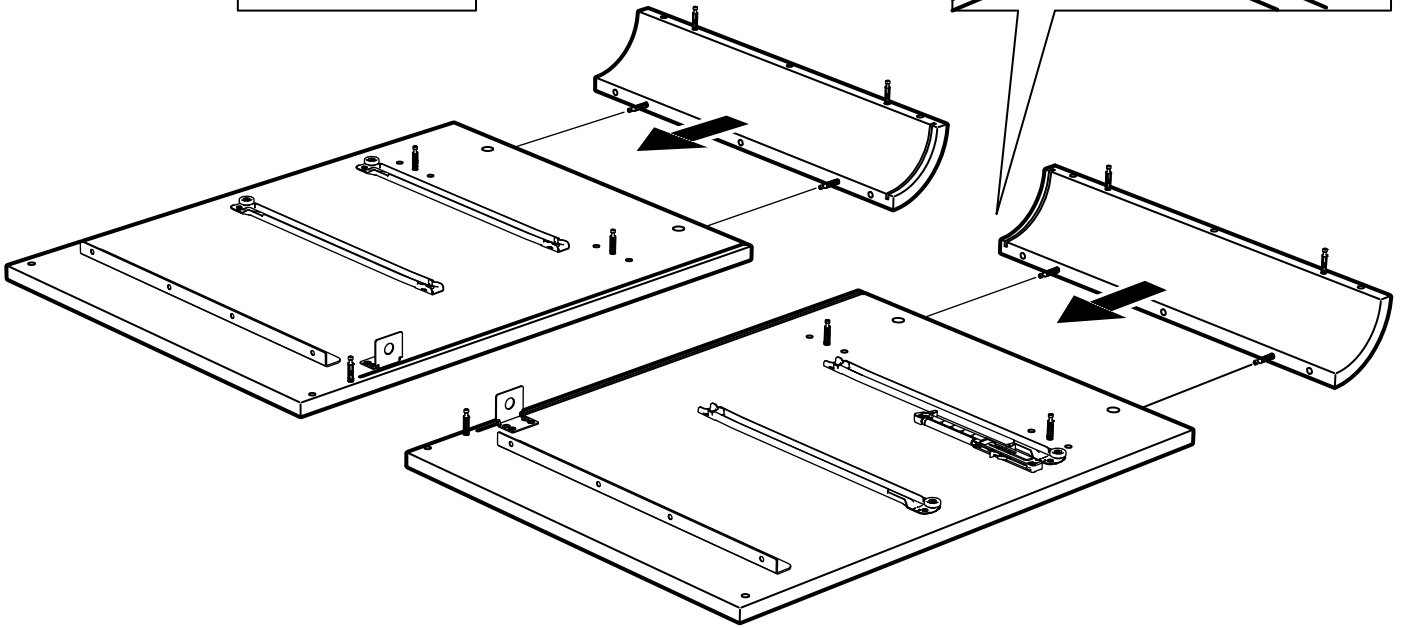
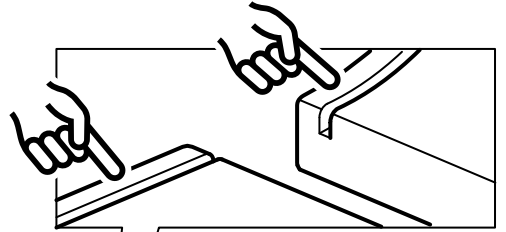
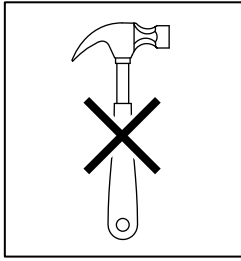

21

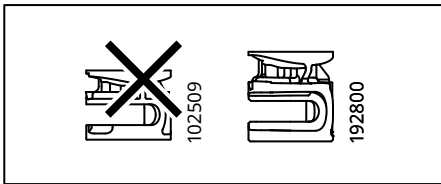

4x

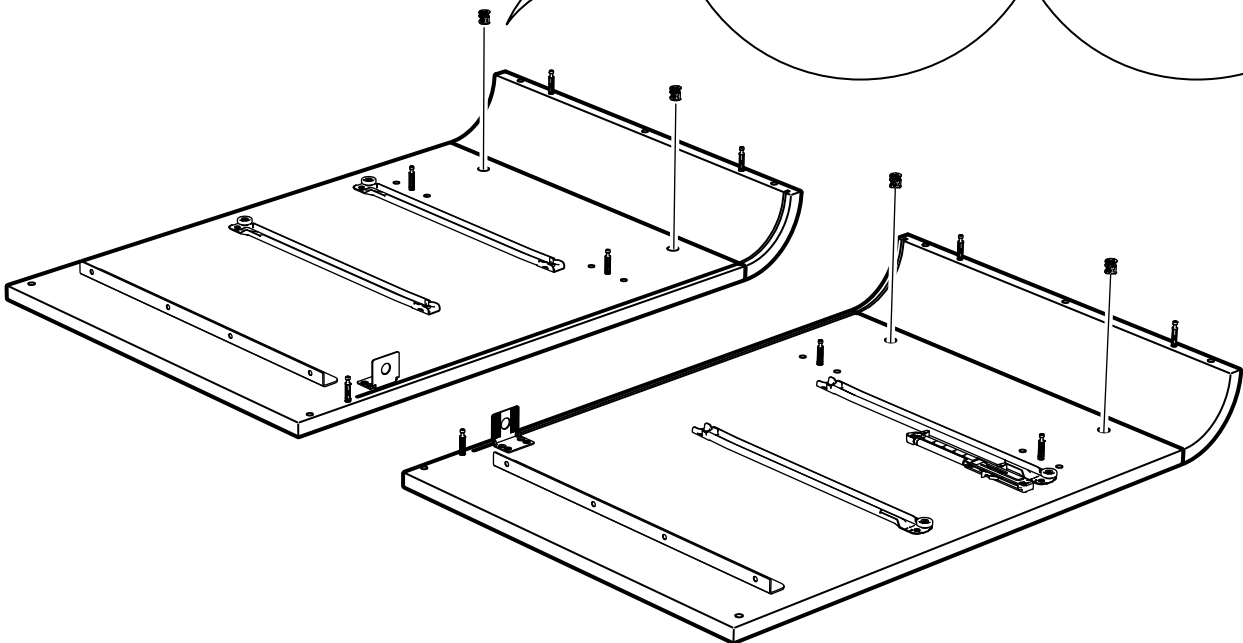
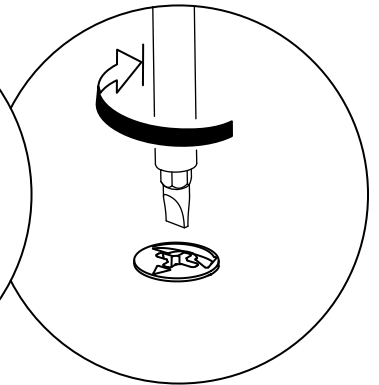
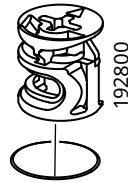

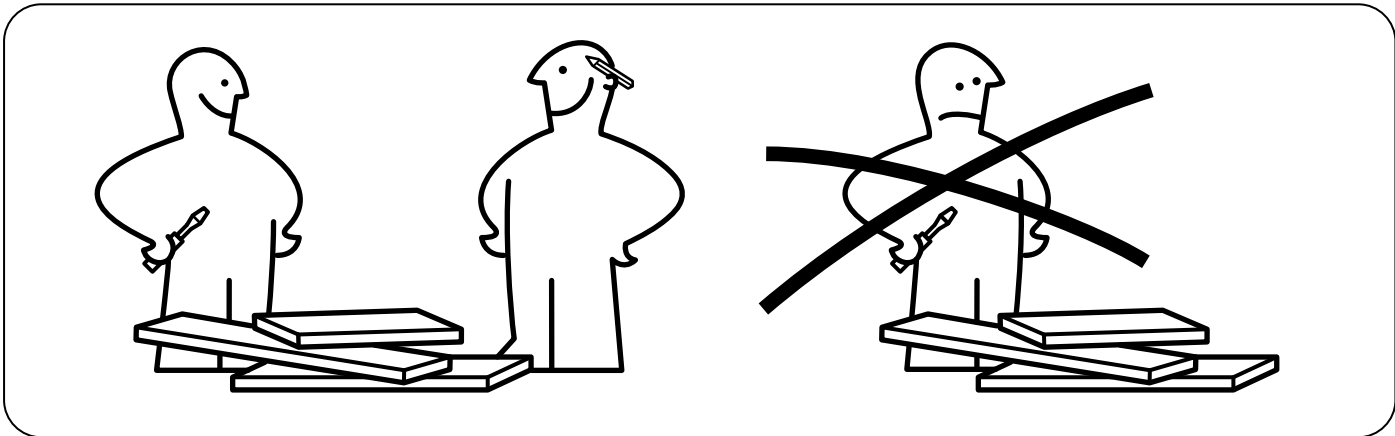

22

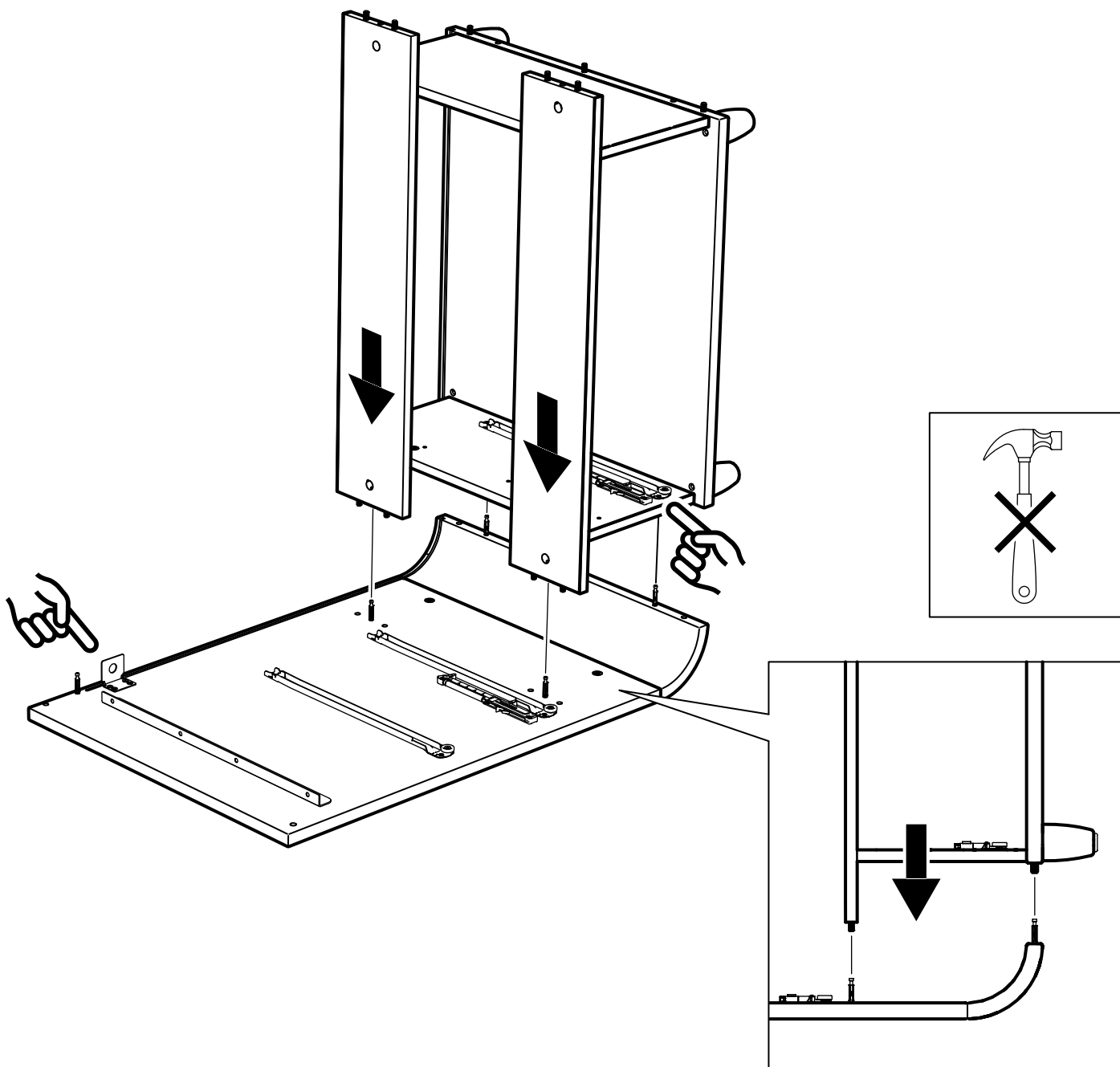

23

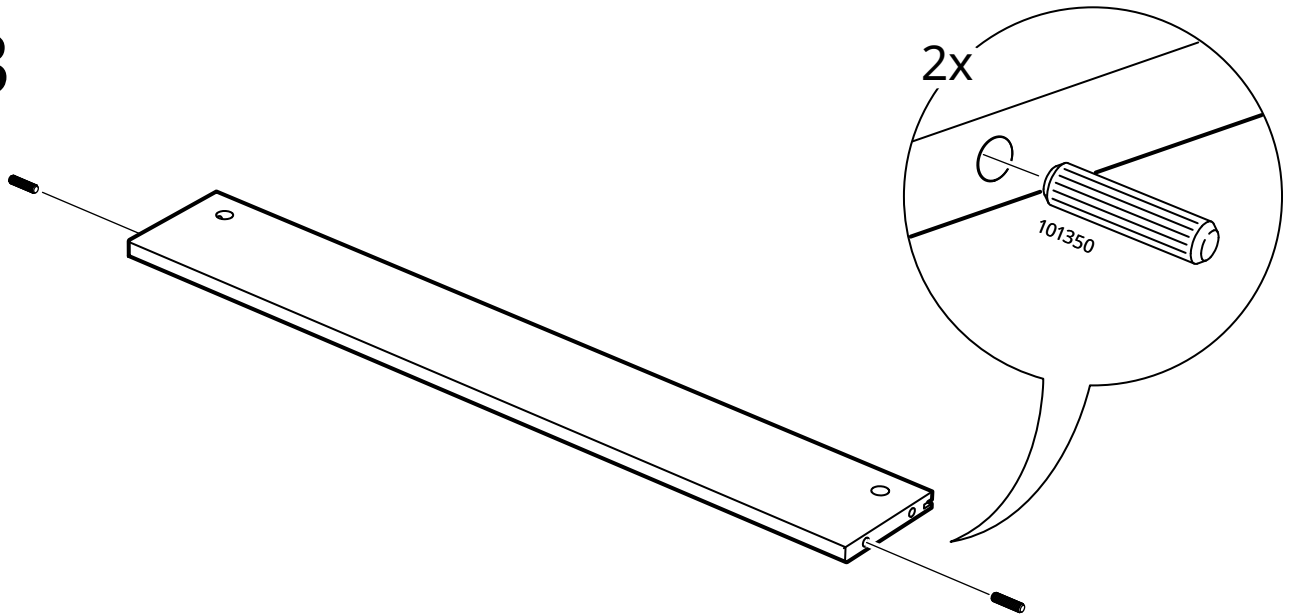

24

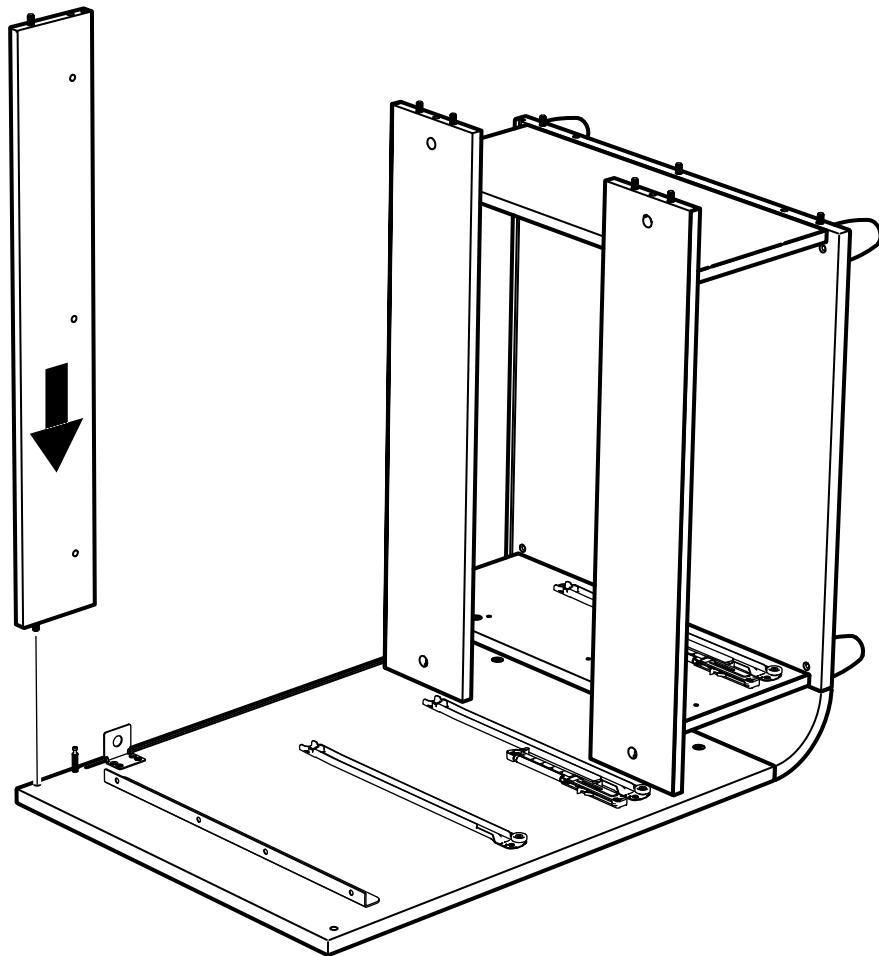

25

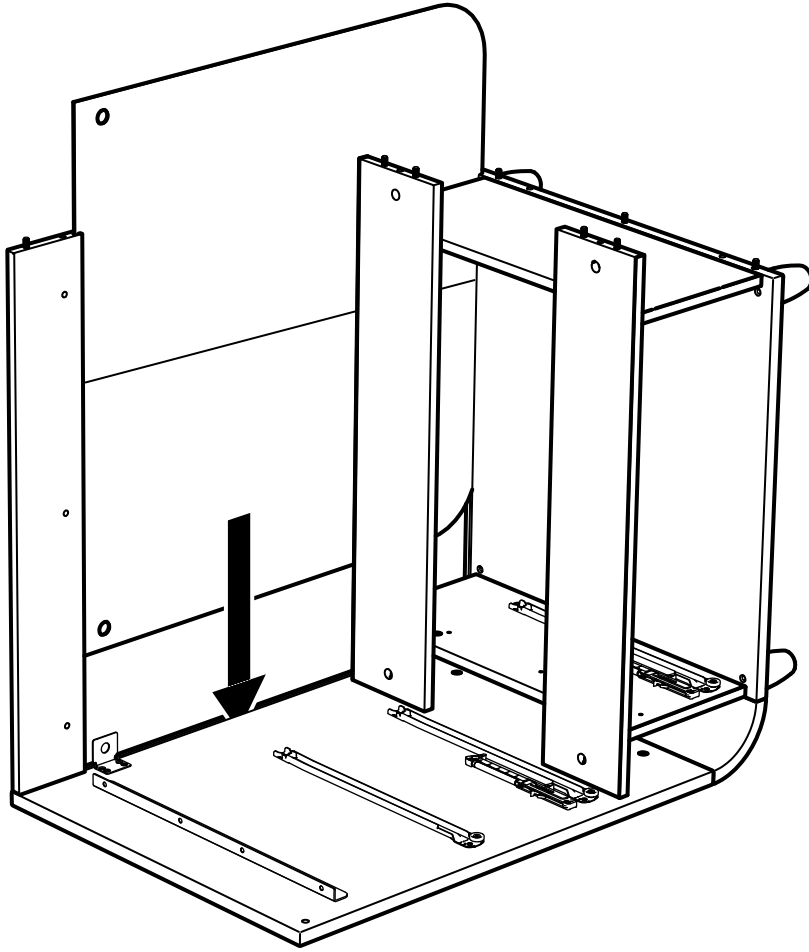

26

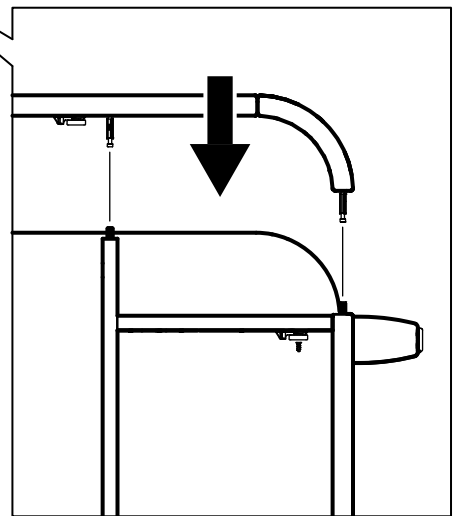
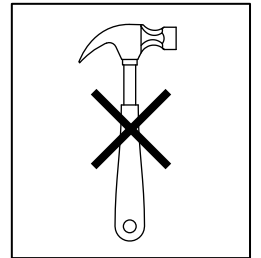
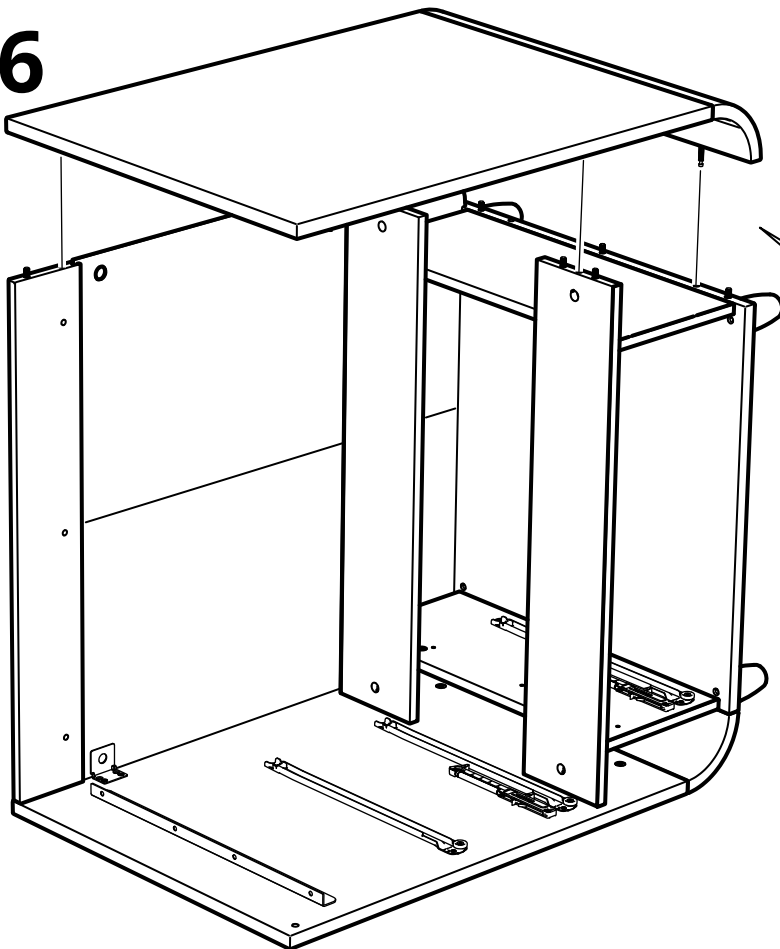

27

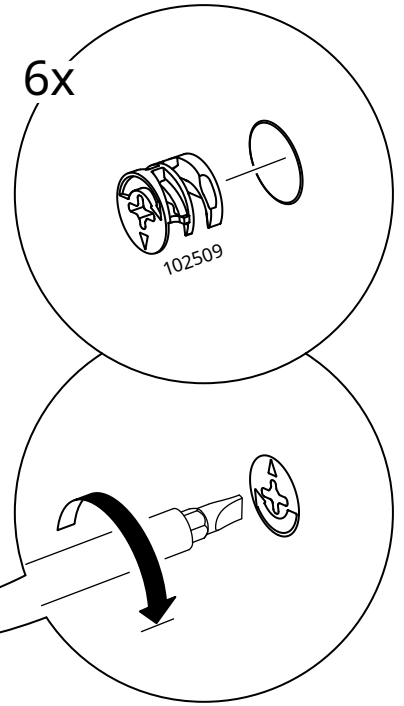
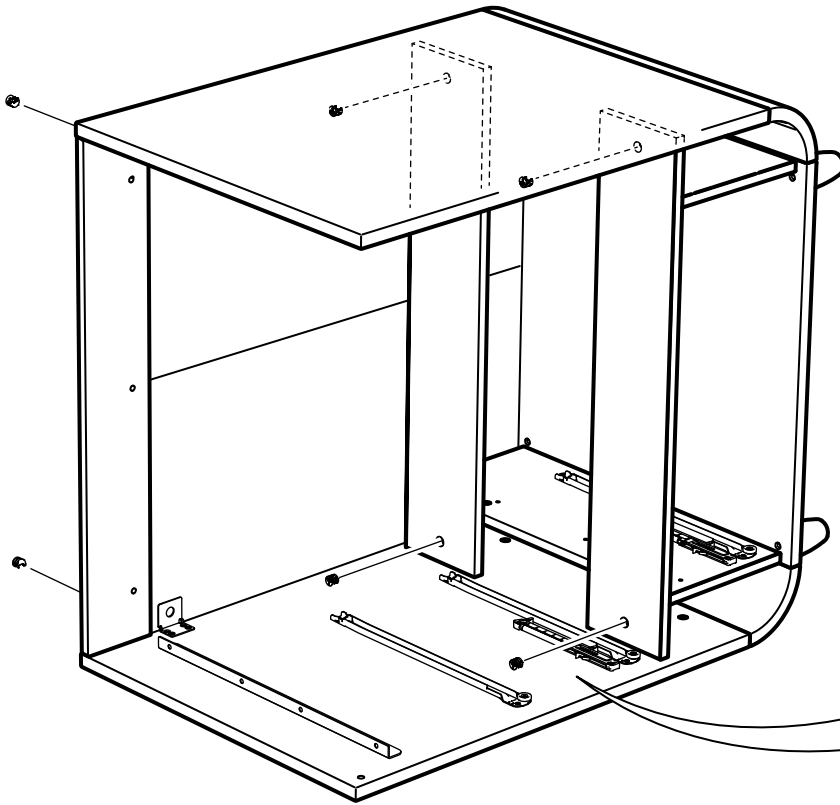
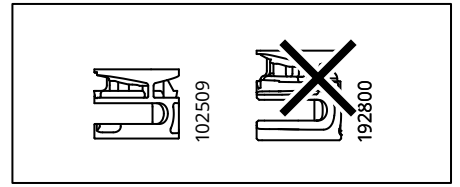

28

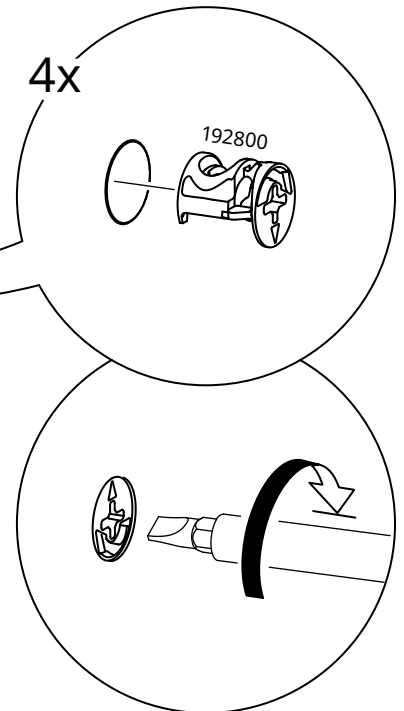
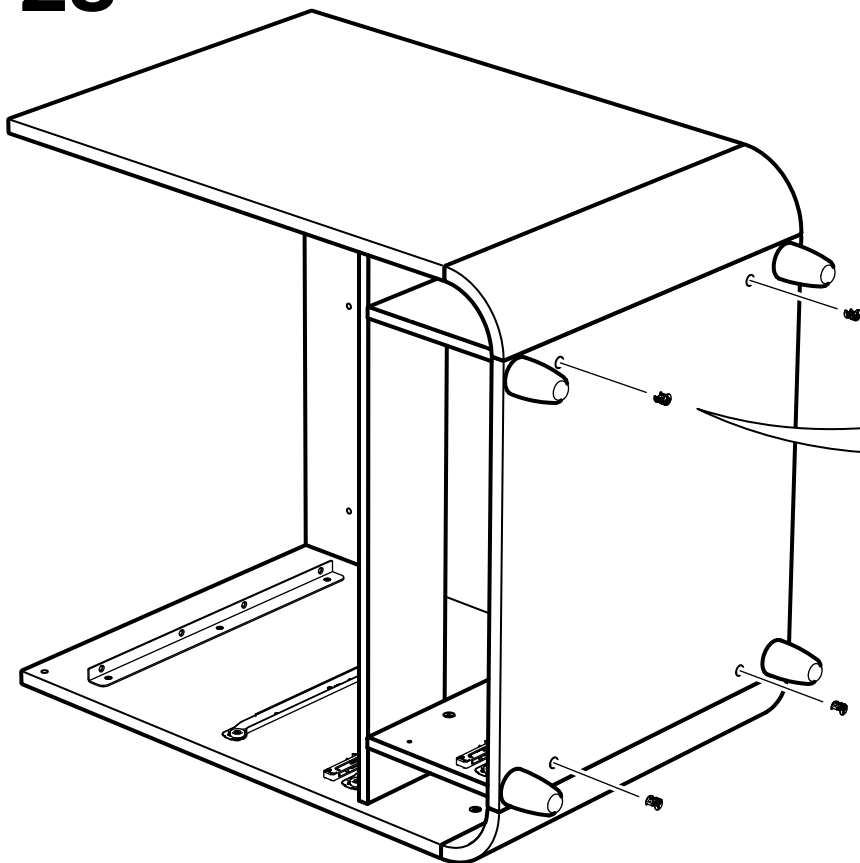
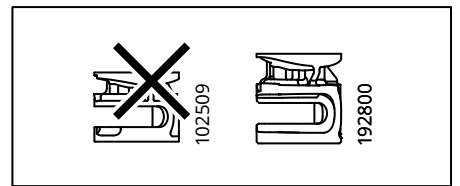

29

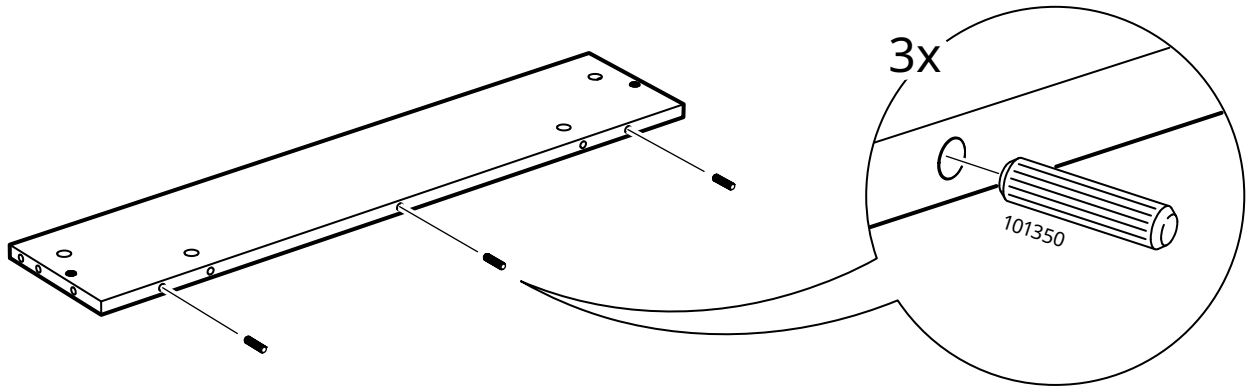

30

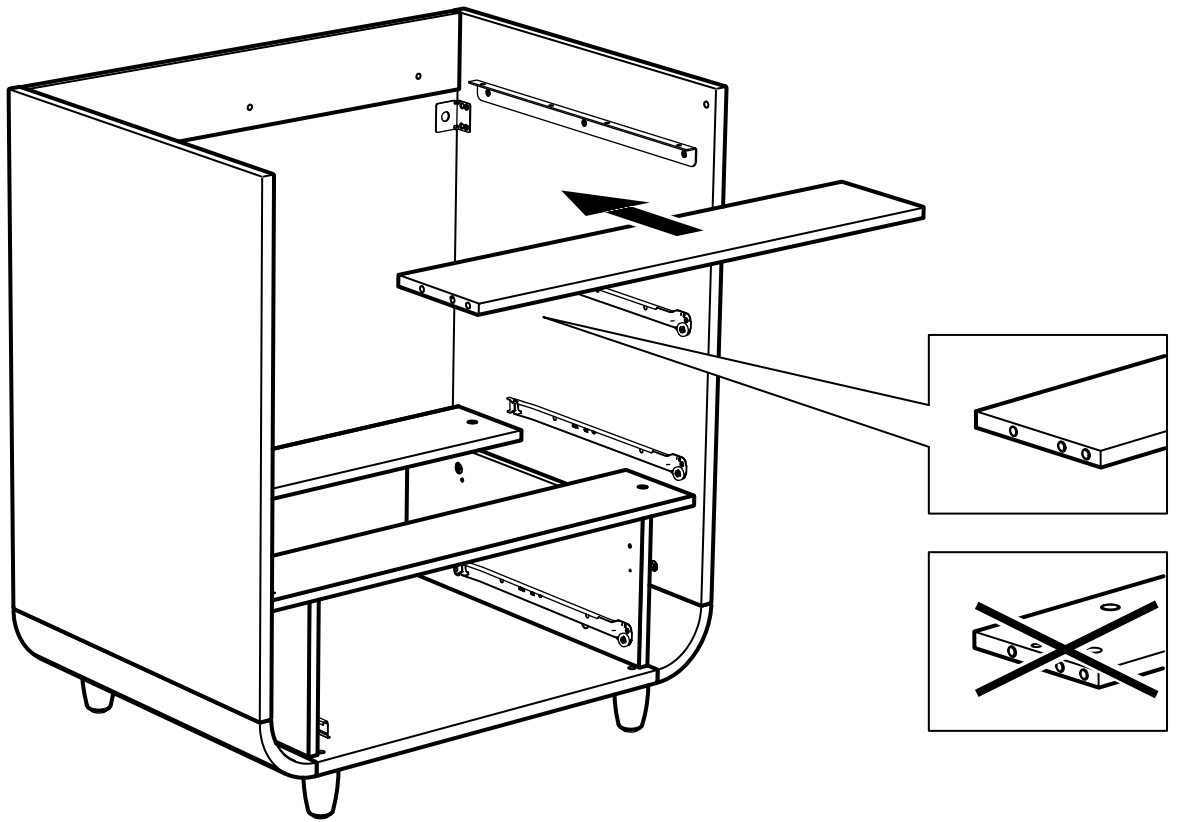

31

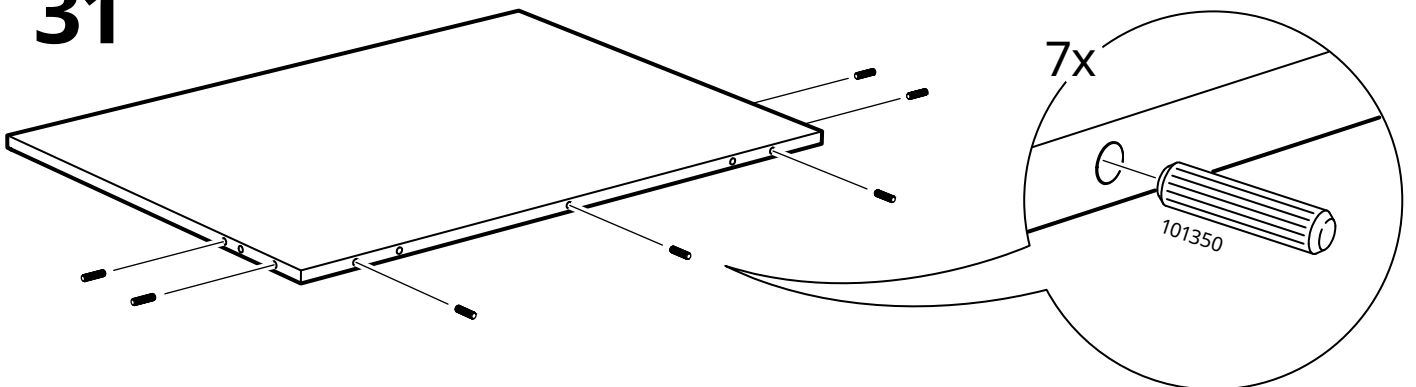

32

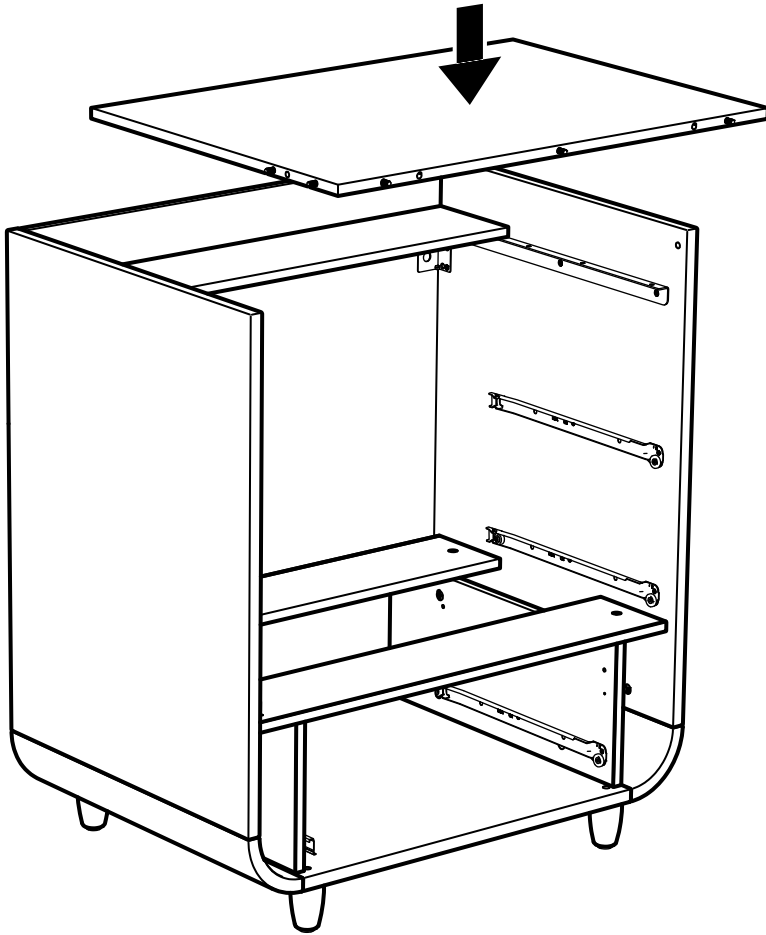

33

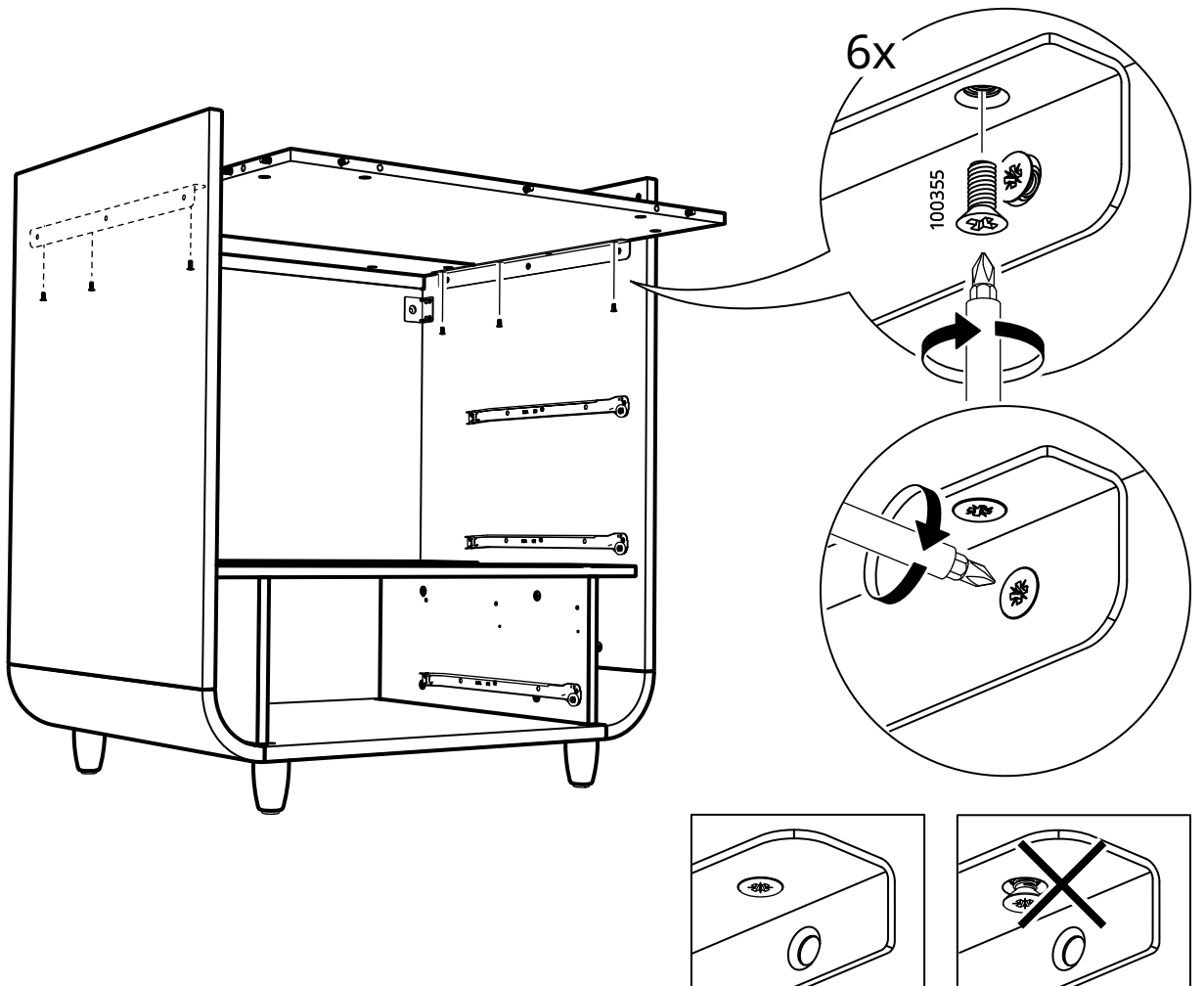

34

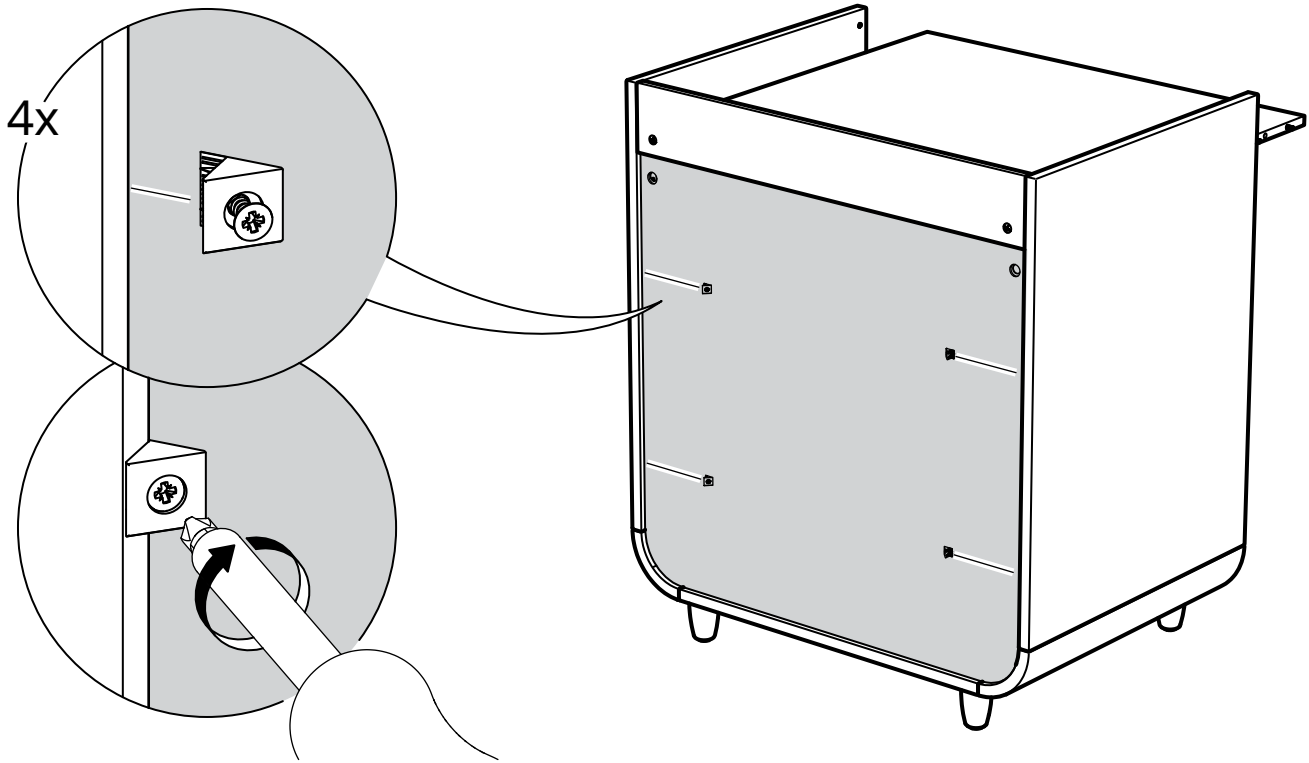

35

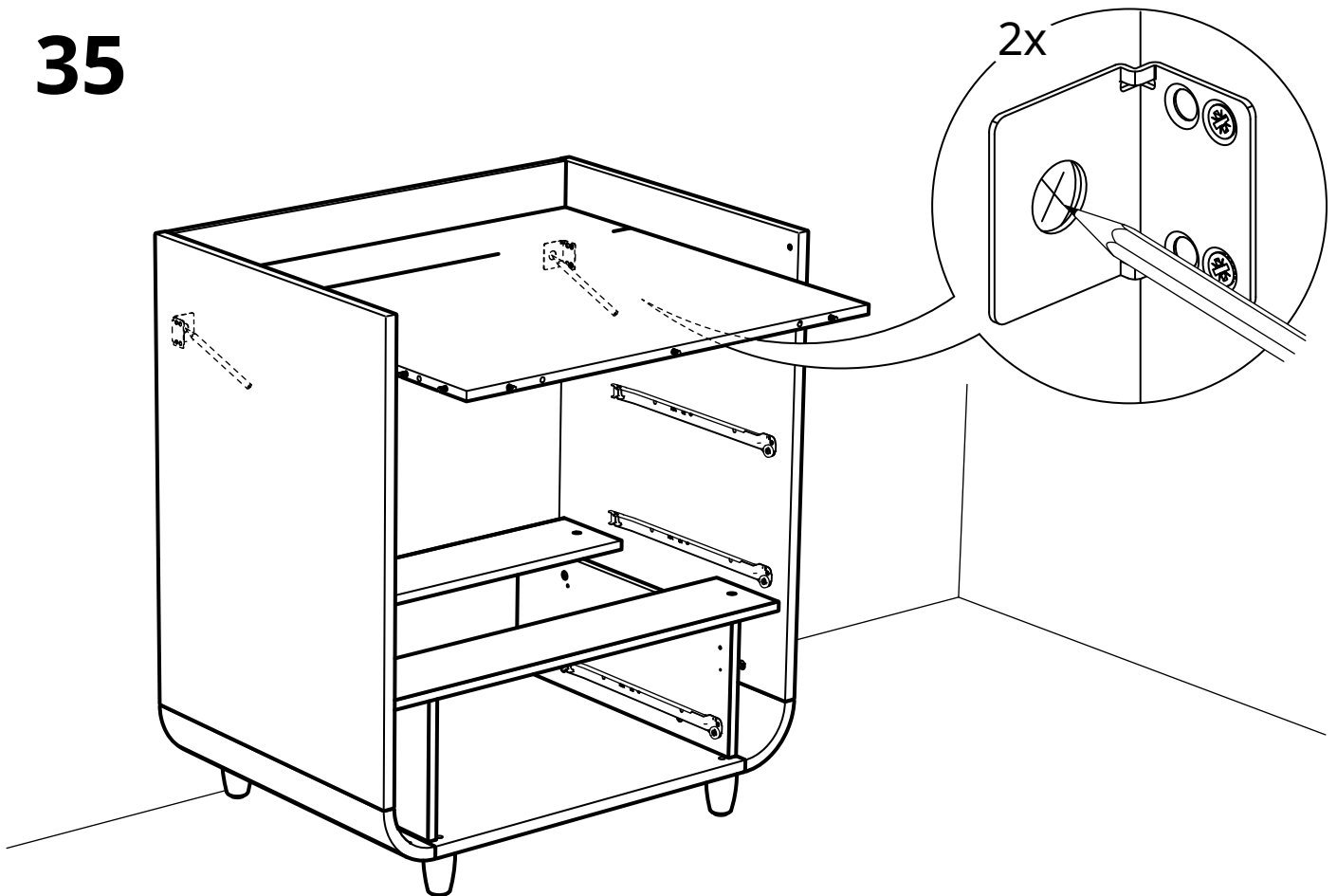

36

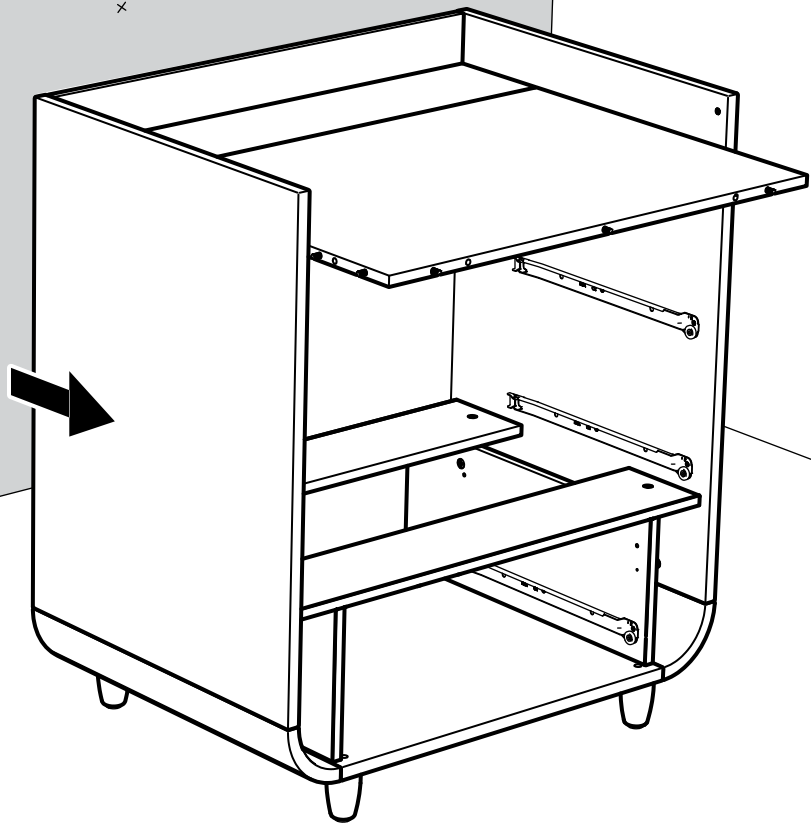

37

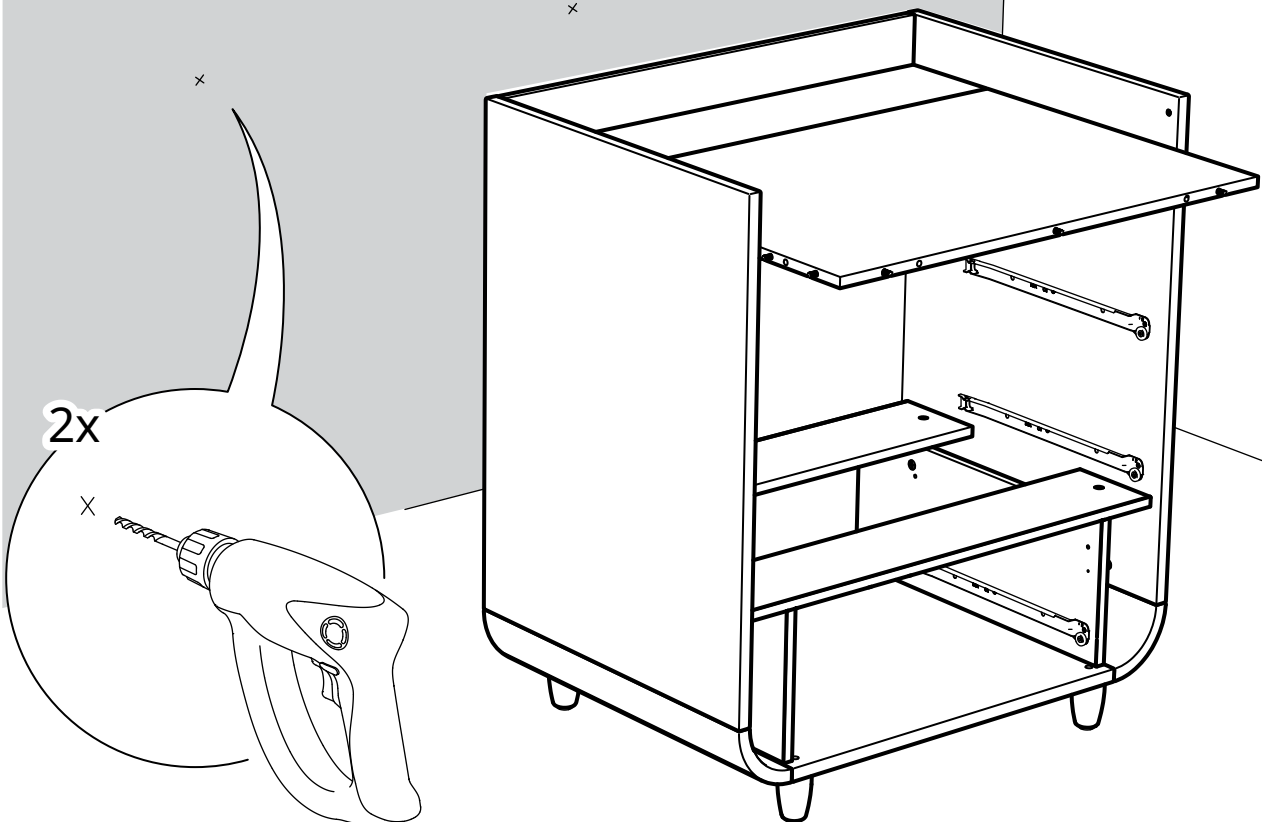

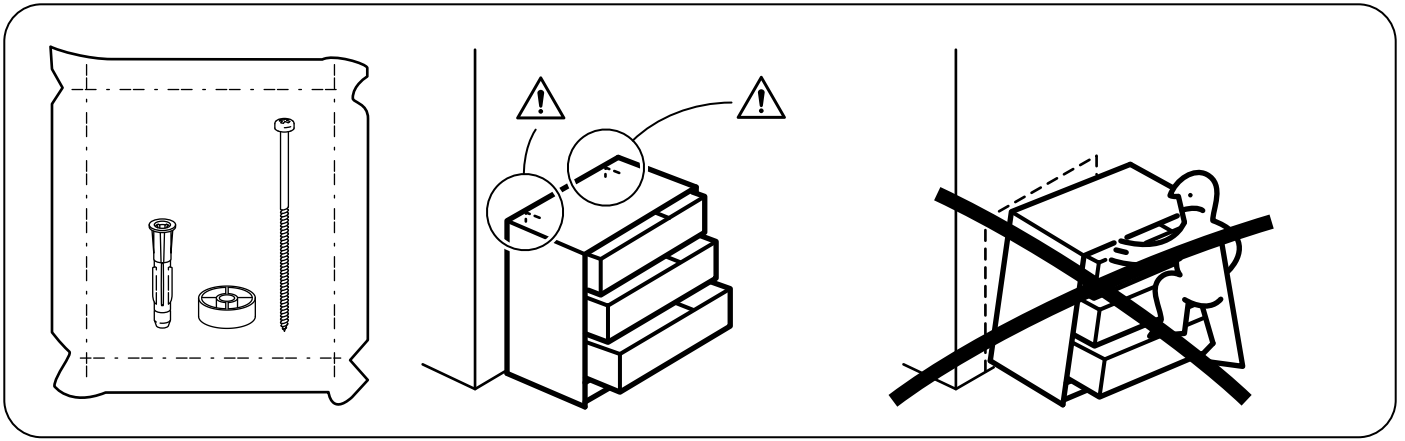

38

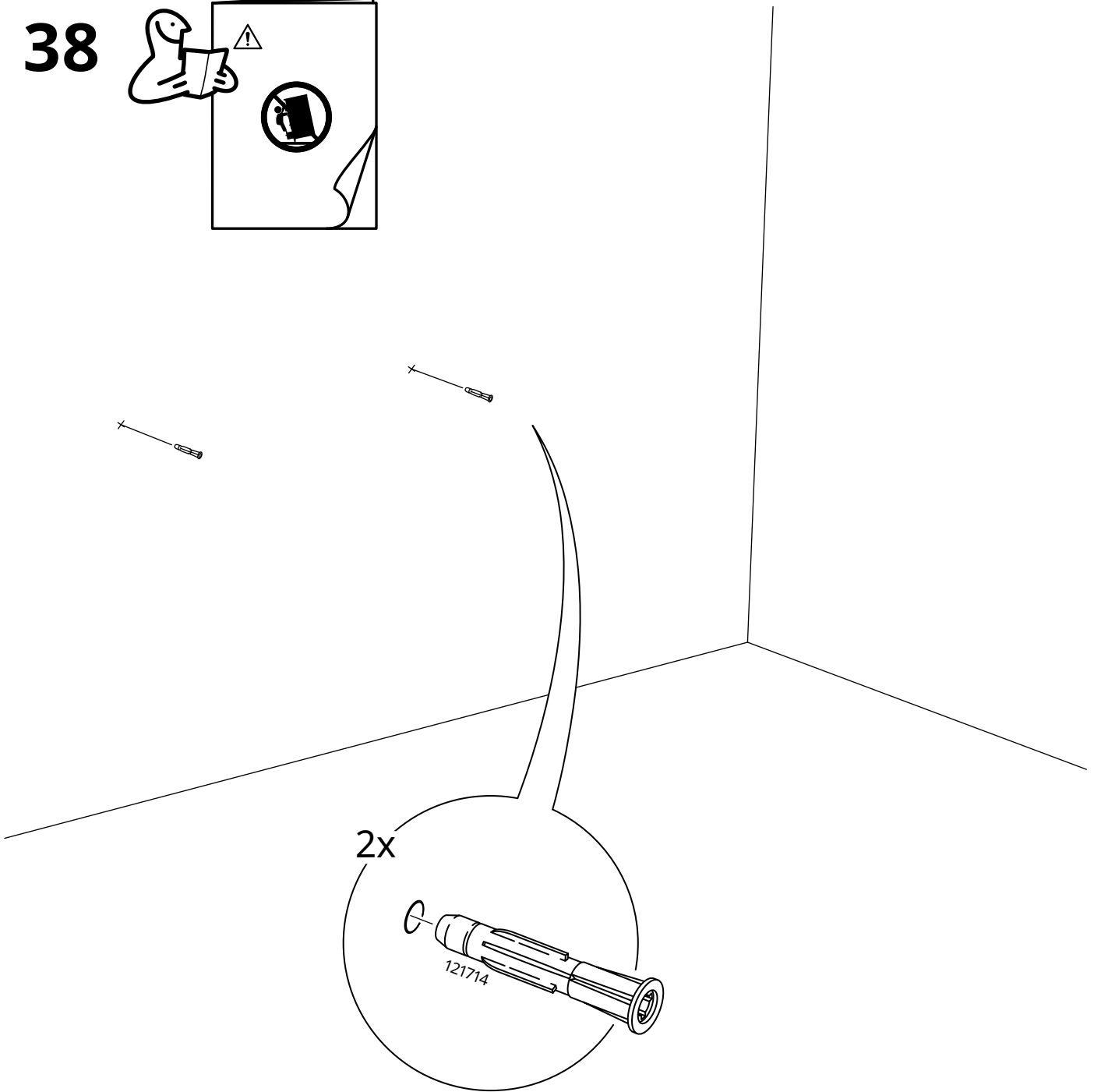
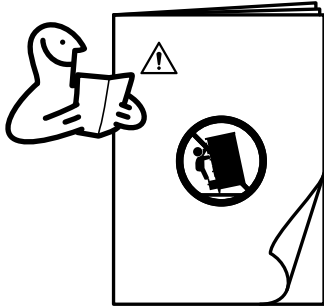

39

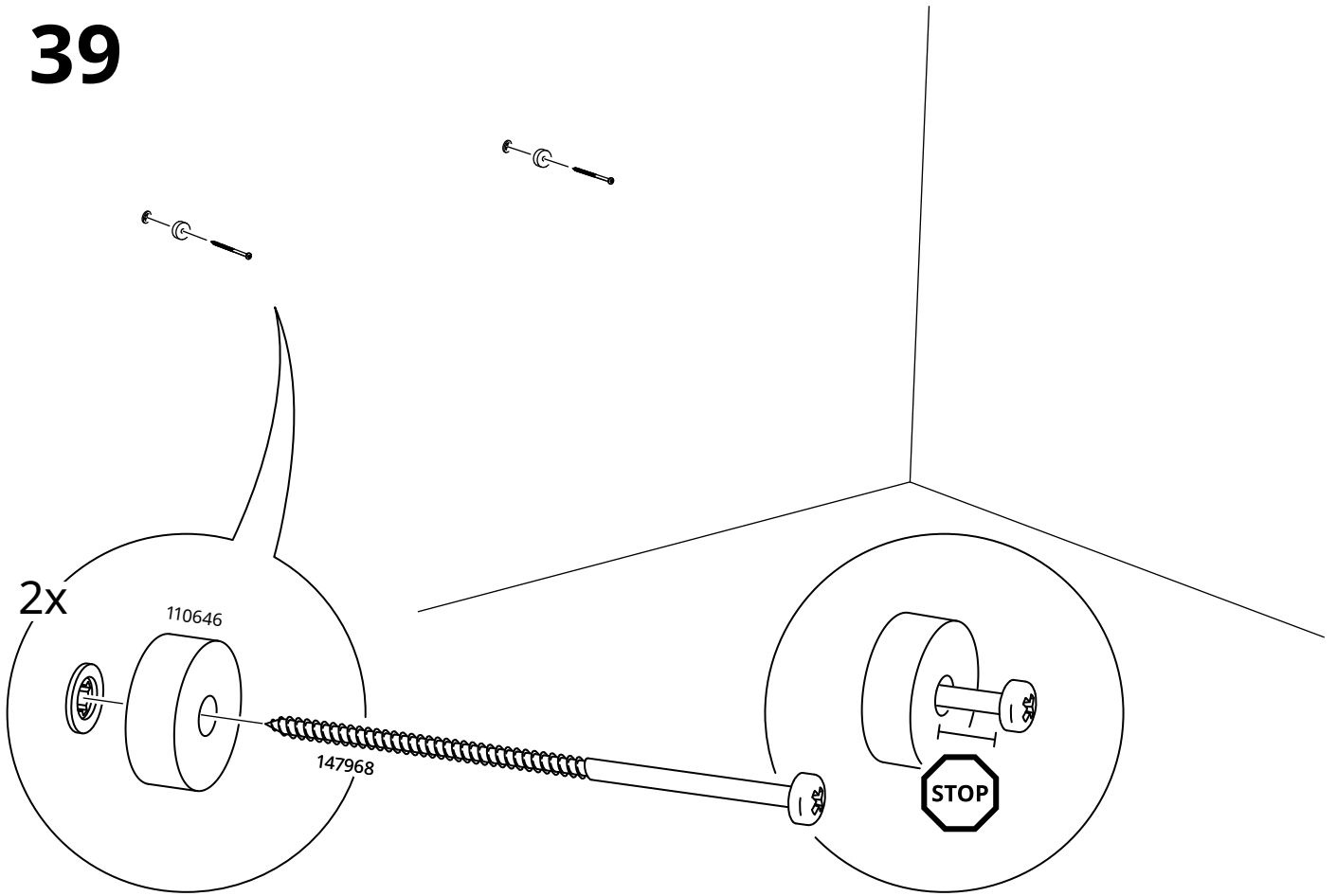

40

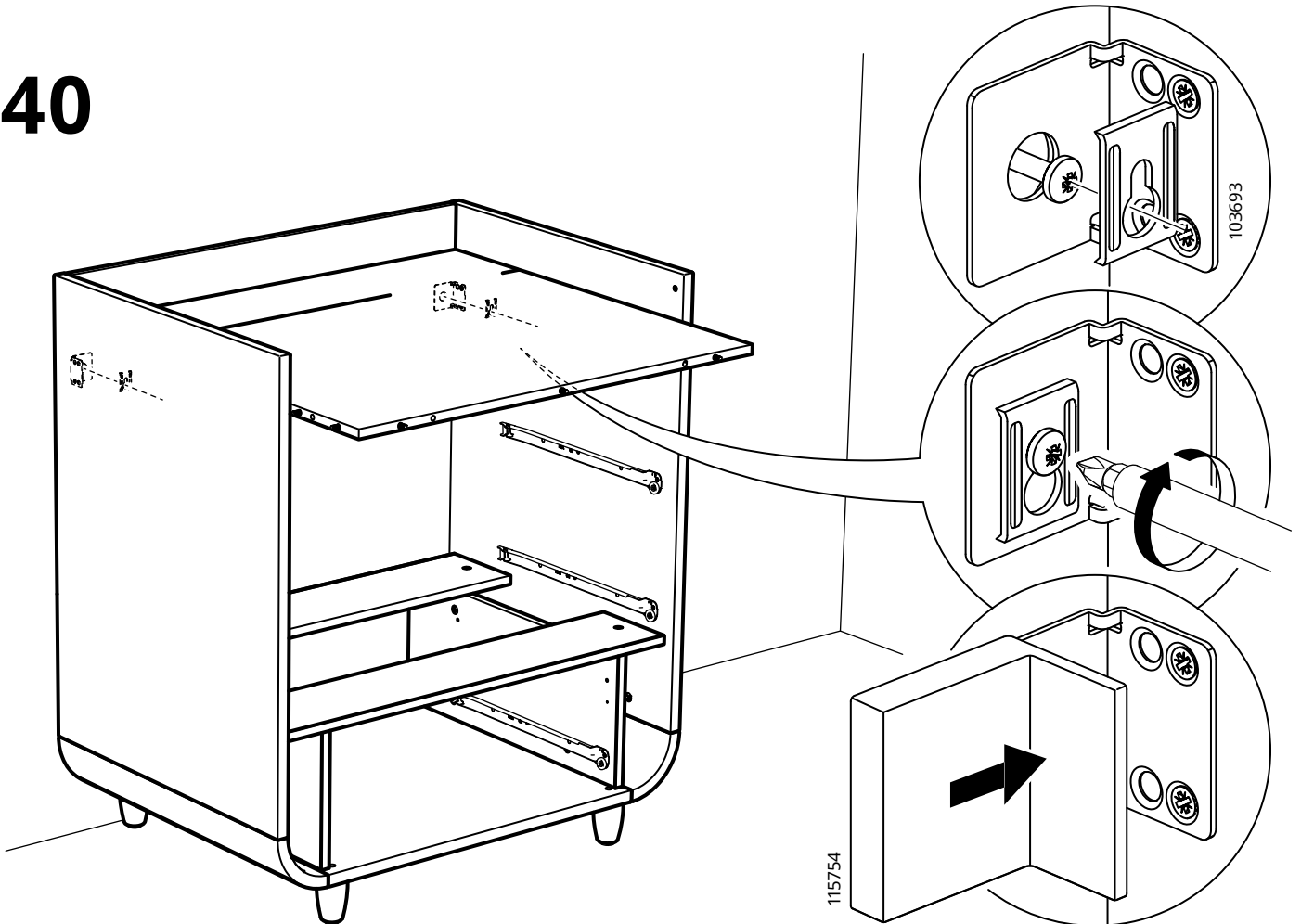

41



12x

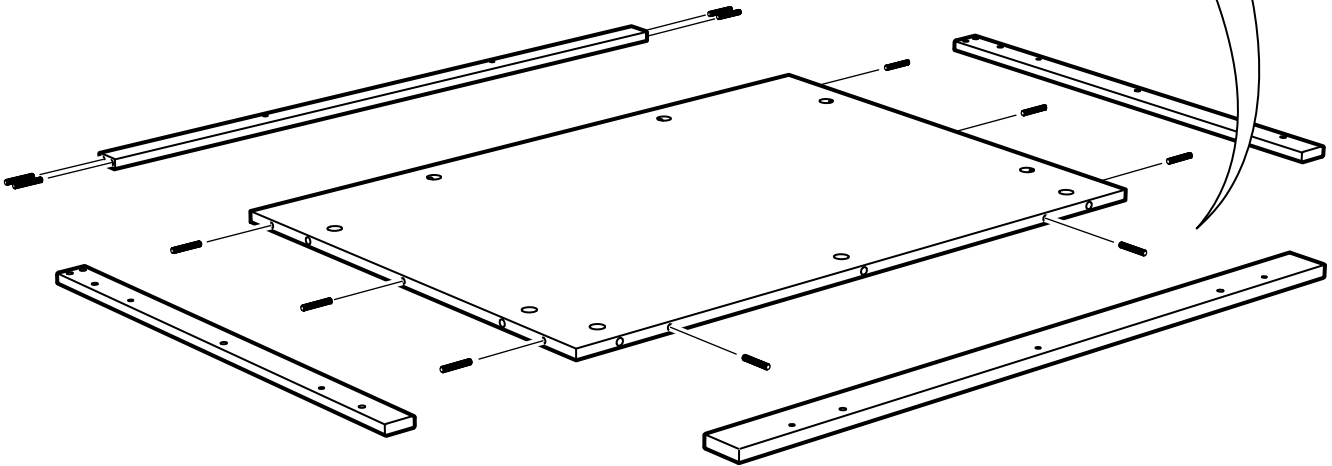
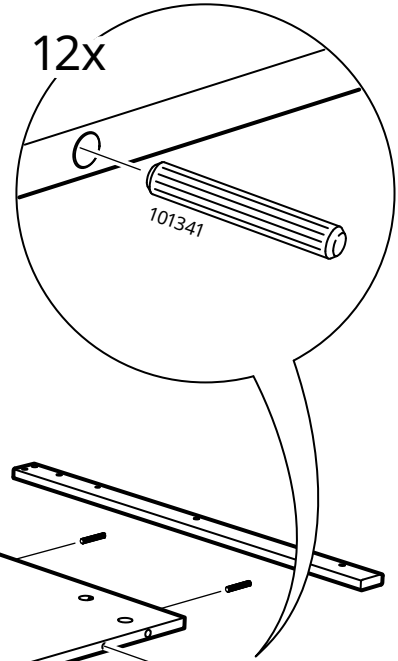

42

9x

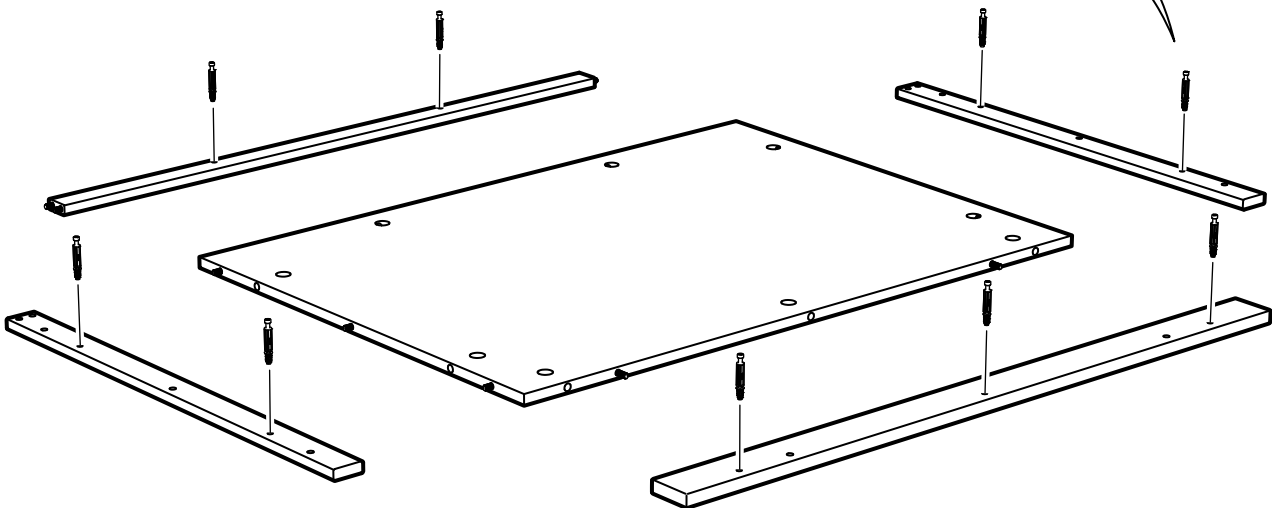
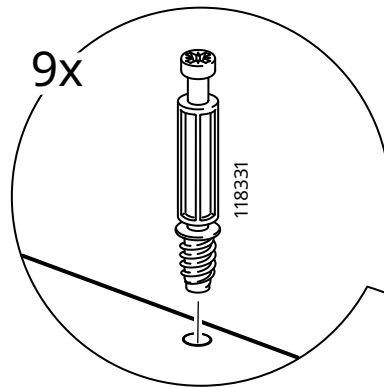

43

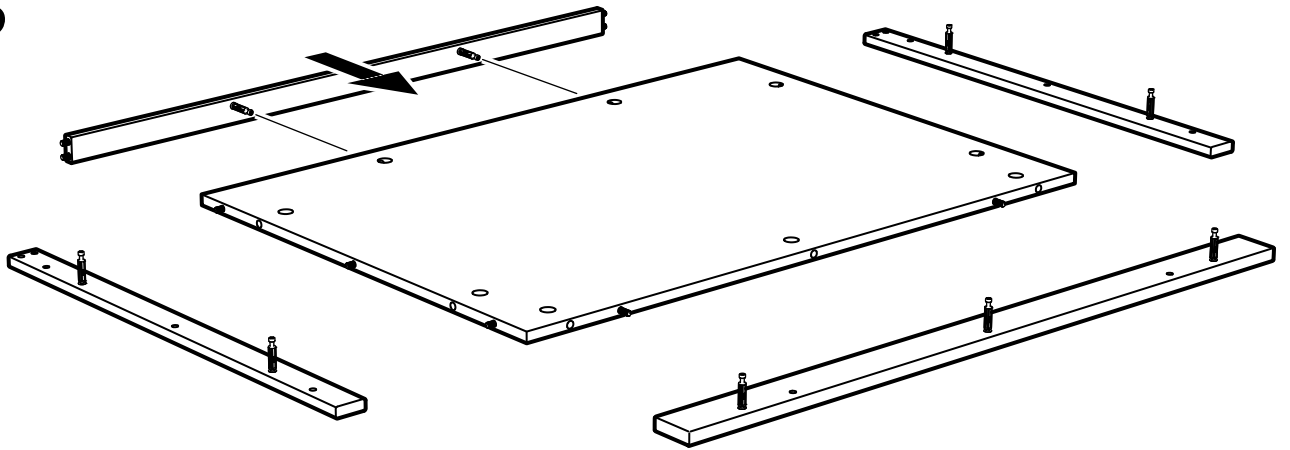

44

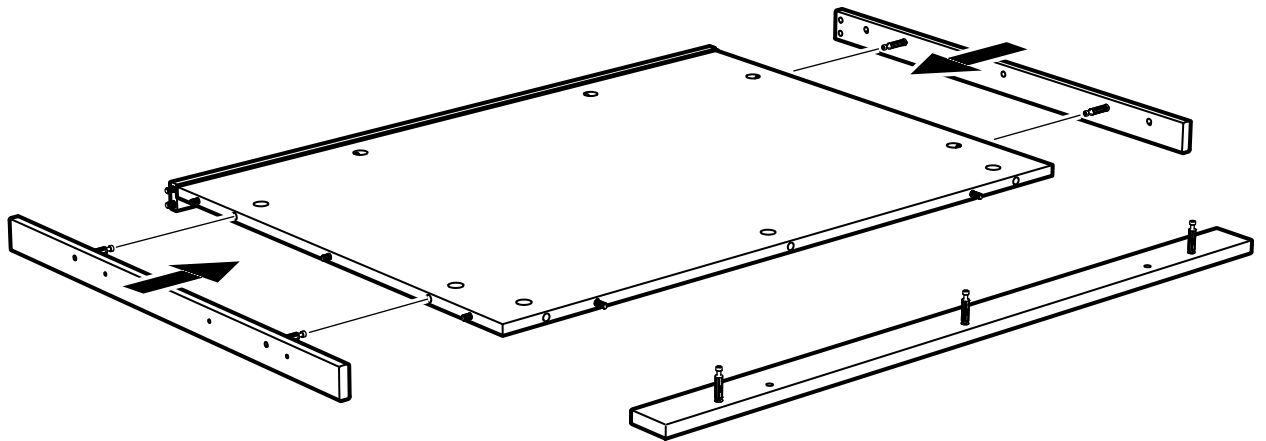

45

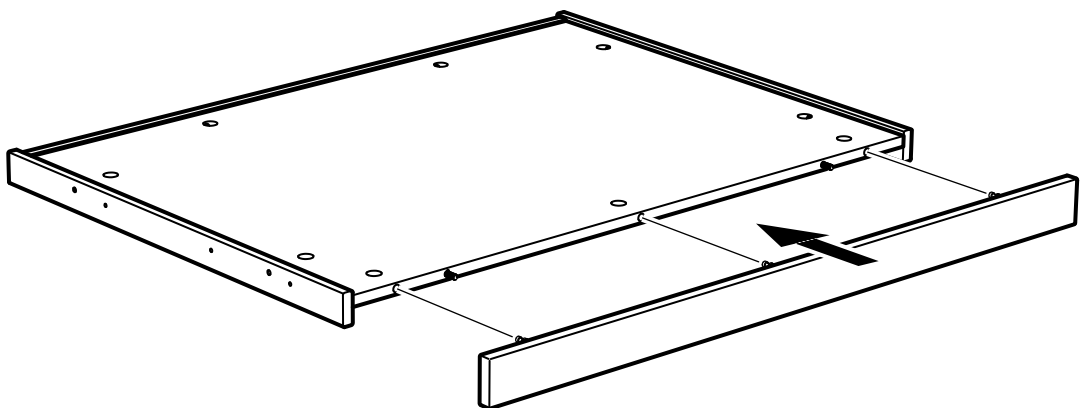

46

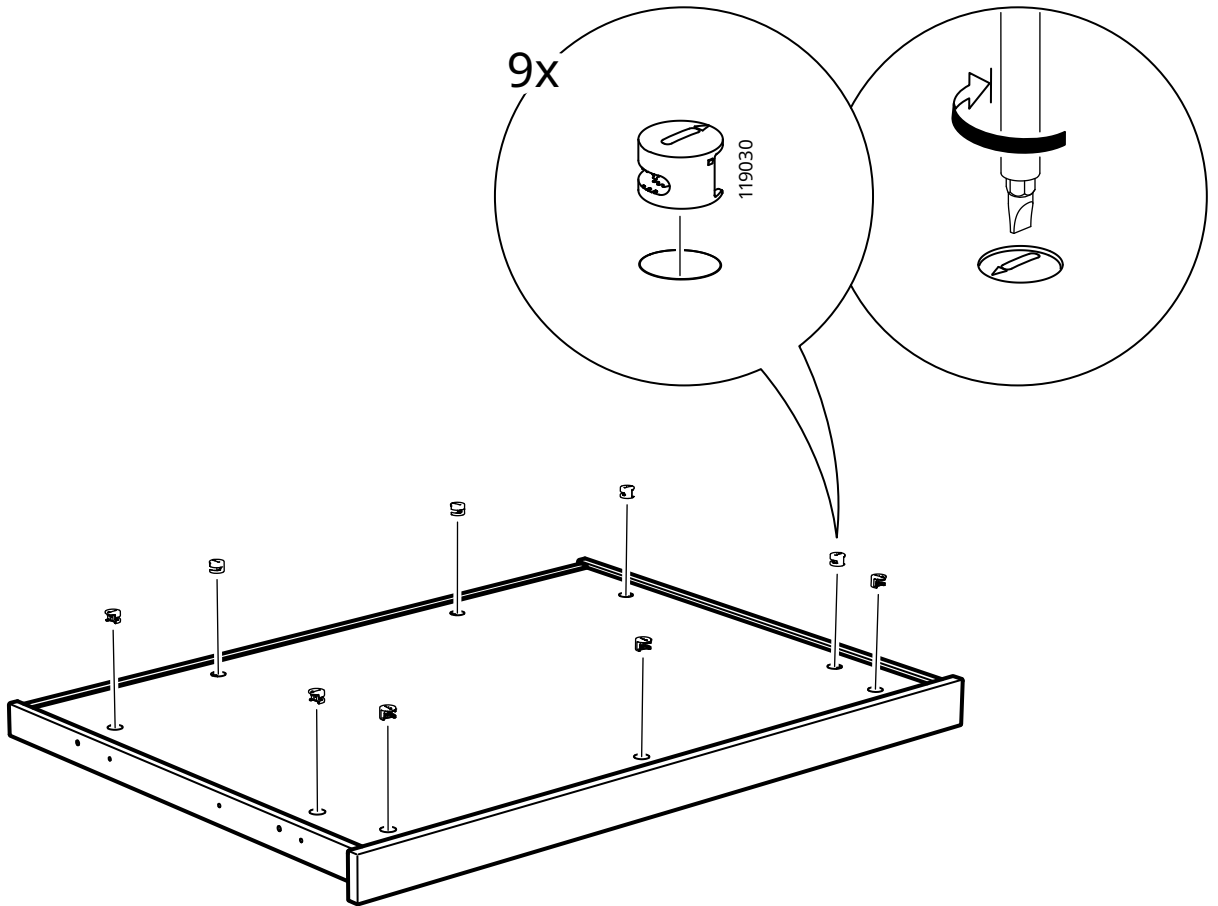

47

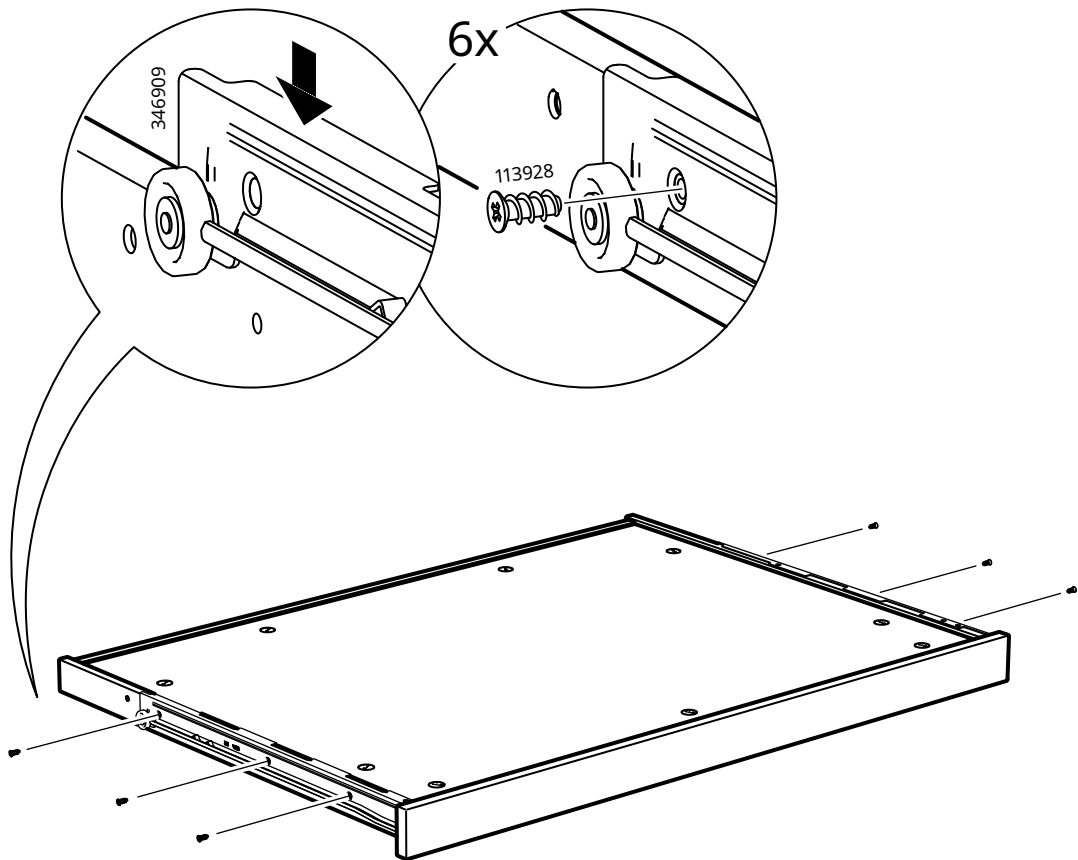

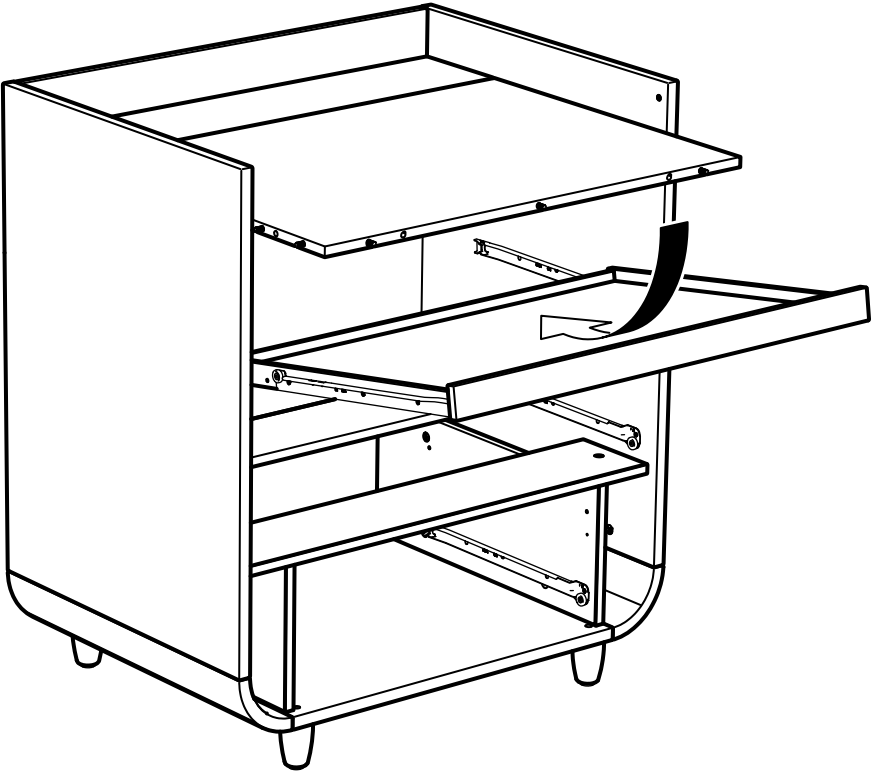

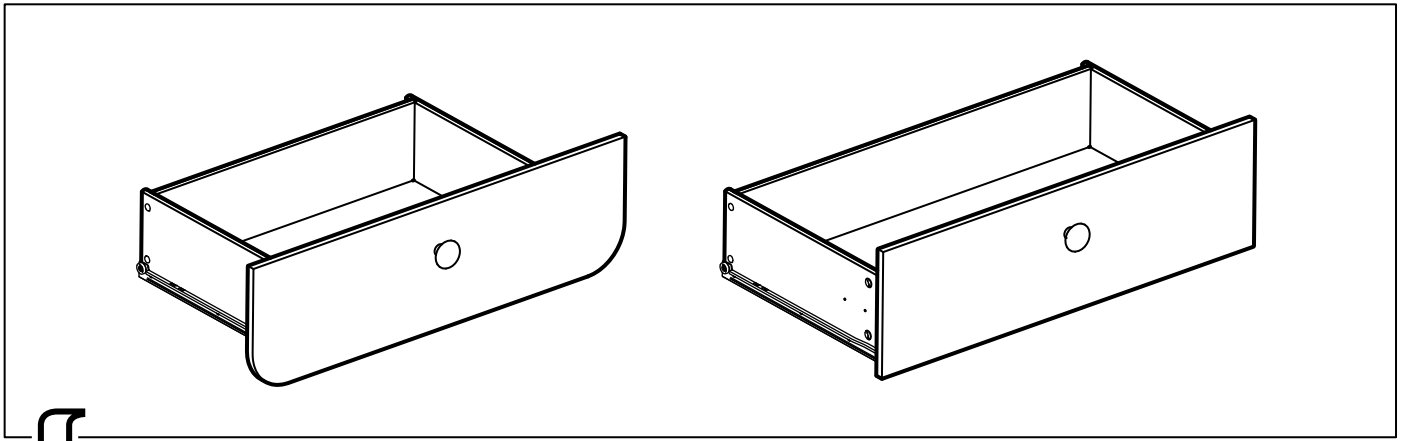

49

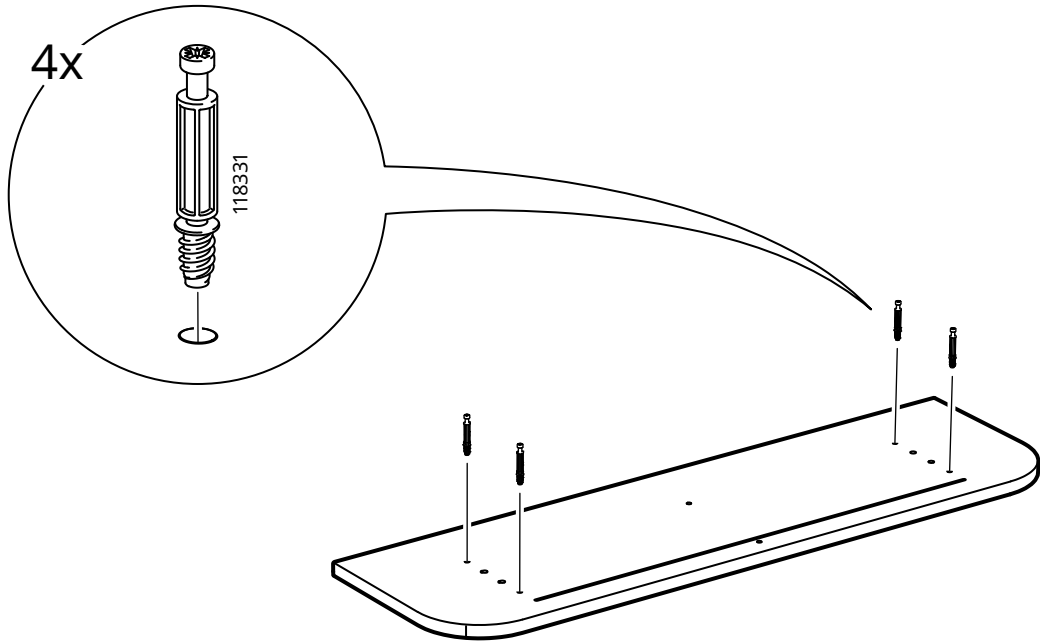

50

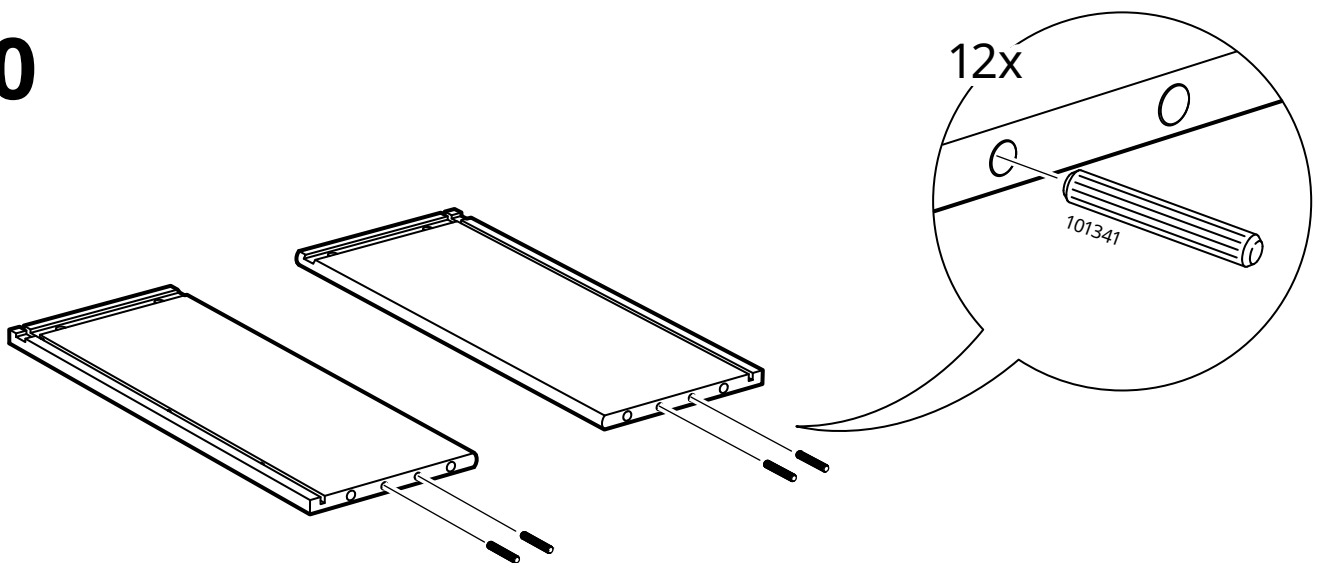

51

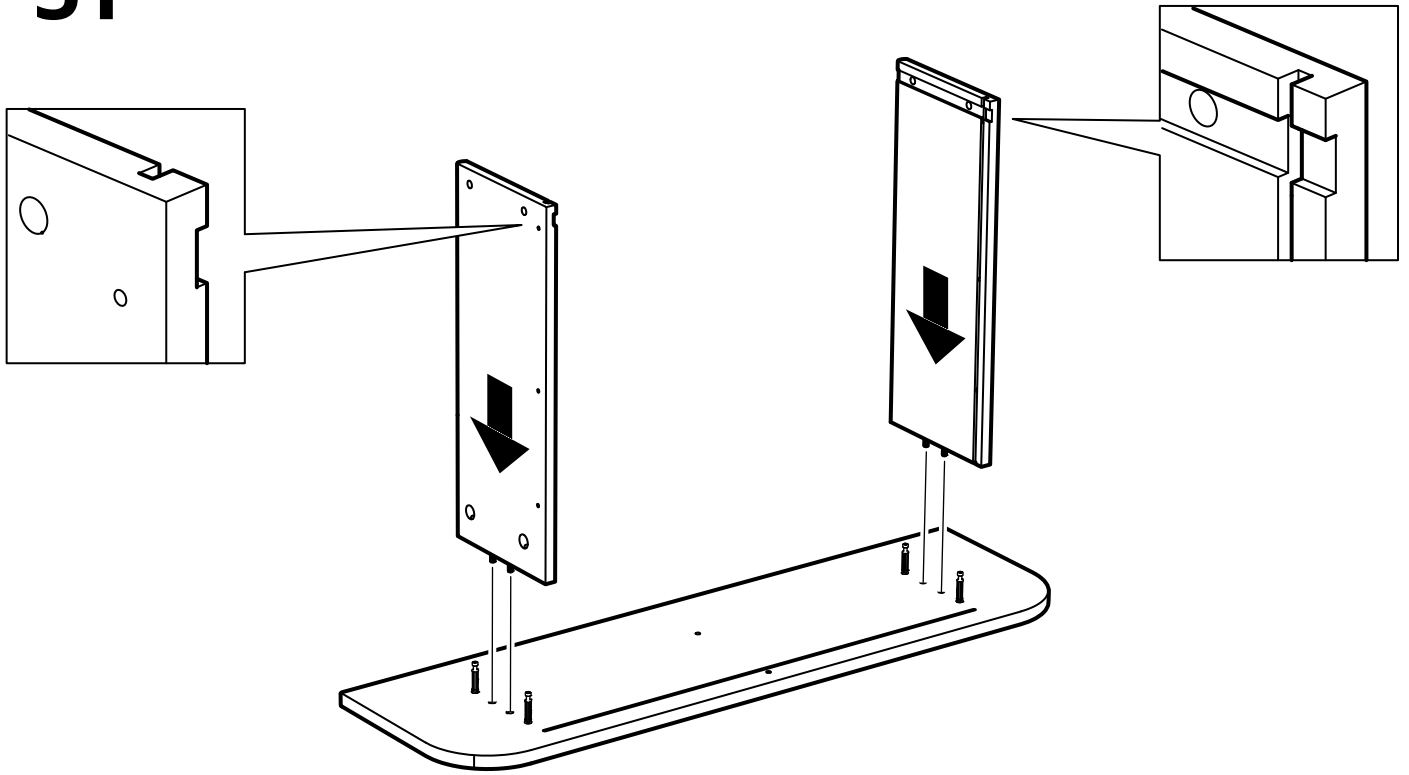

52

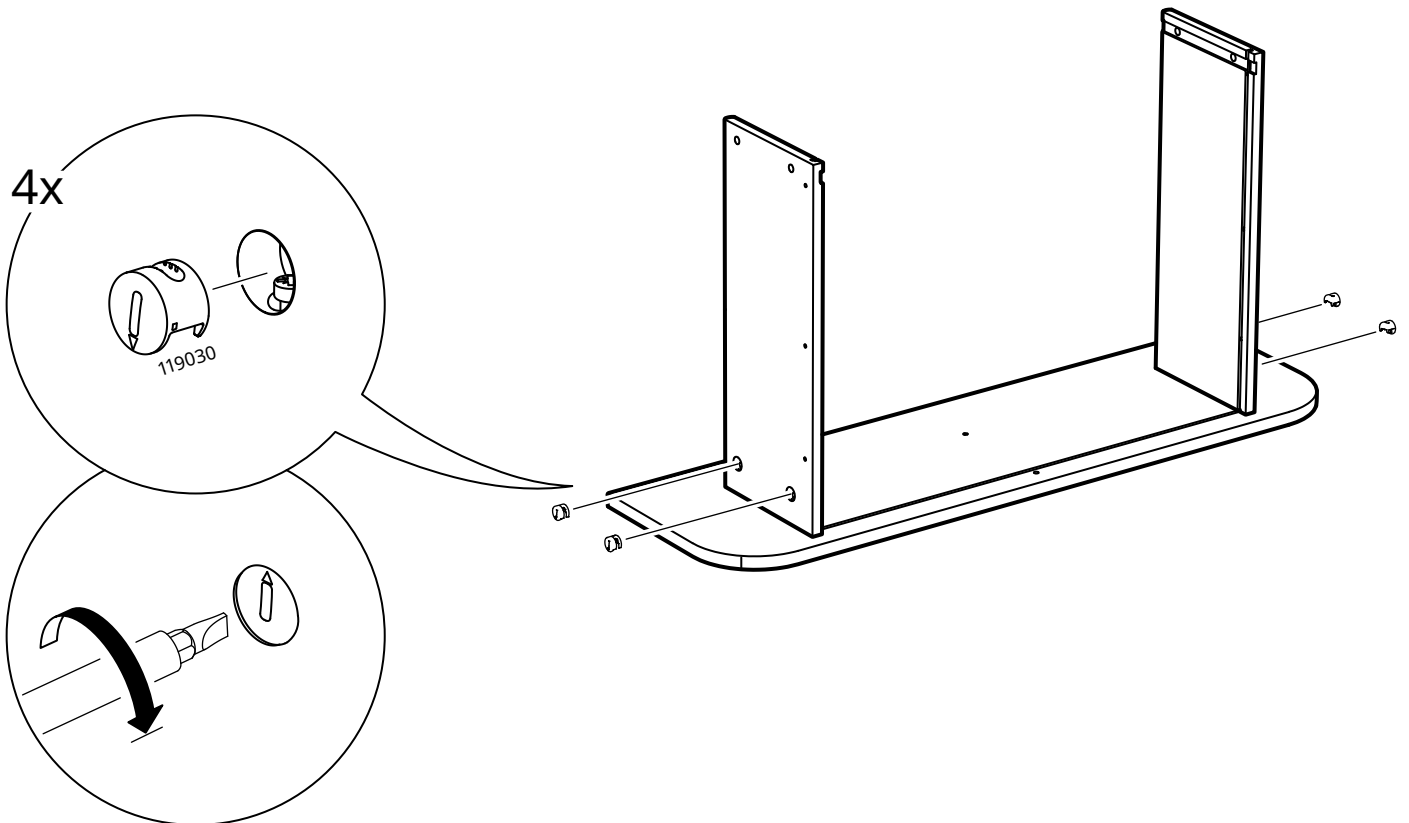

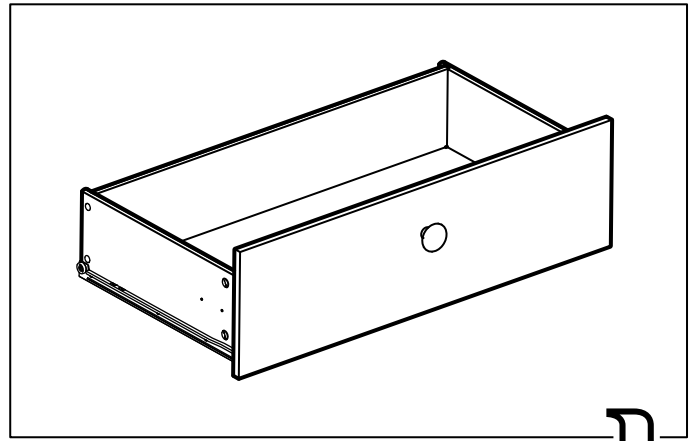
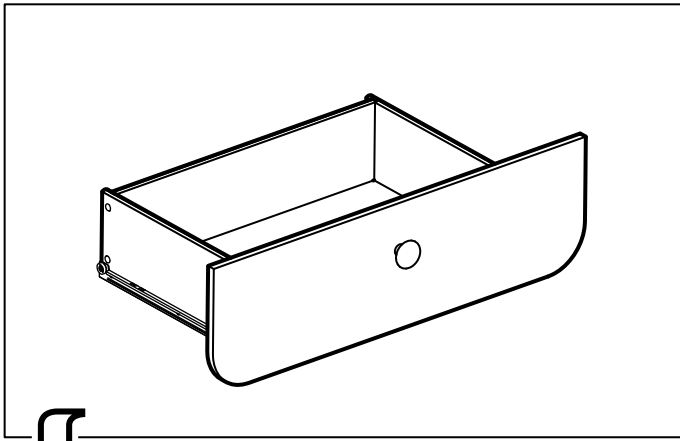

53

53

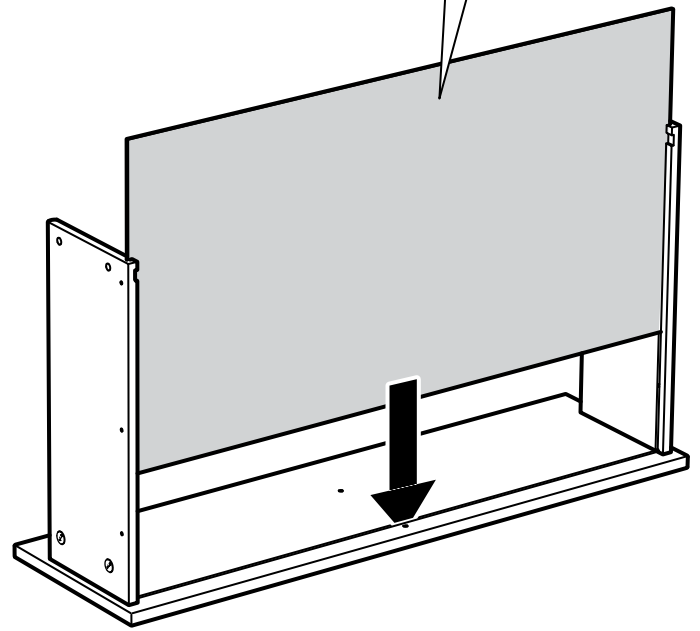
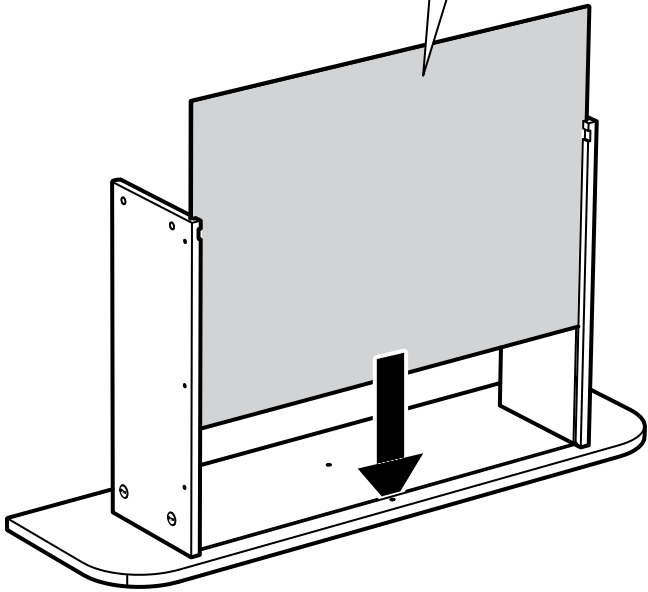
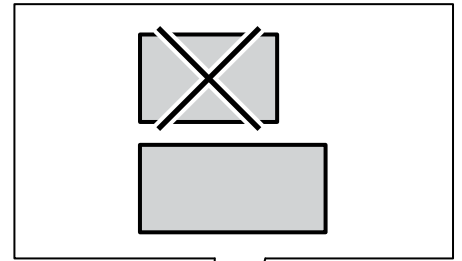
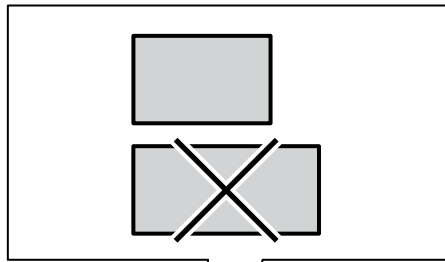

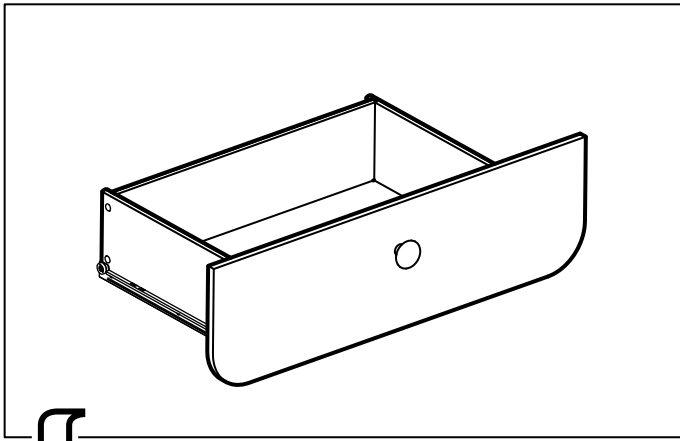

54

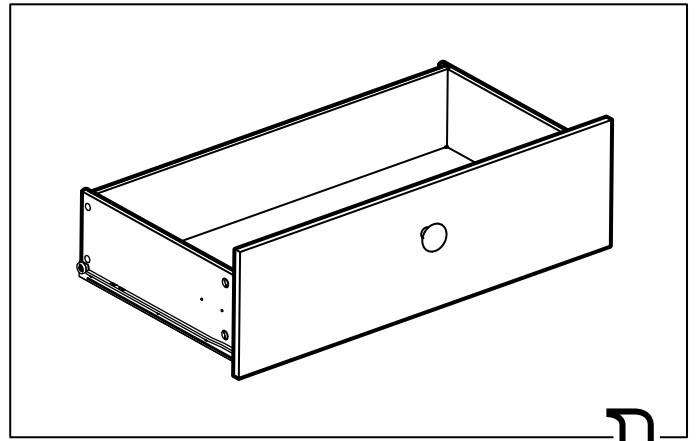

54

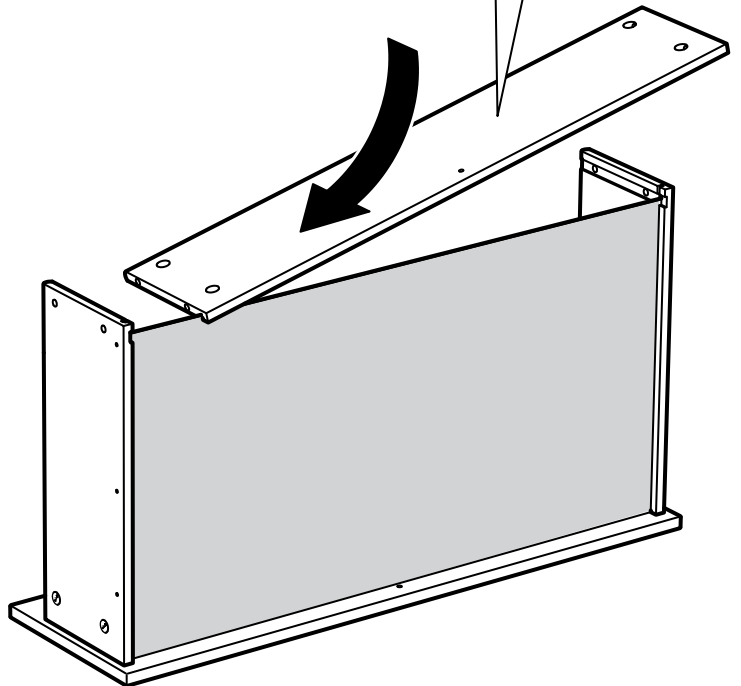
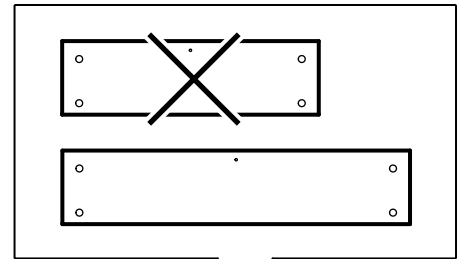
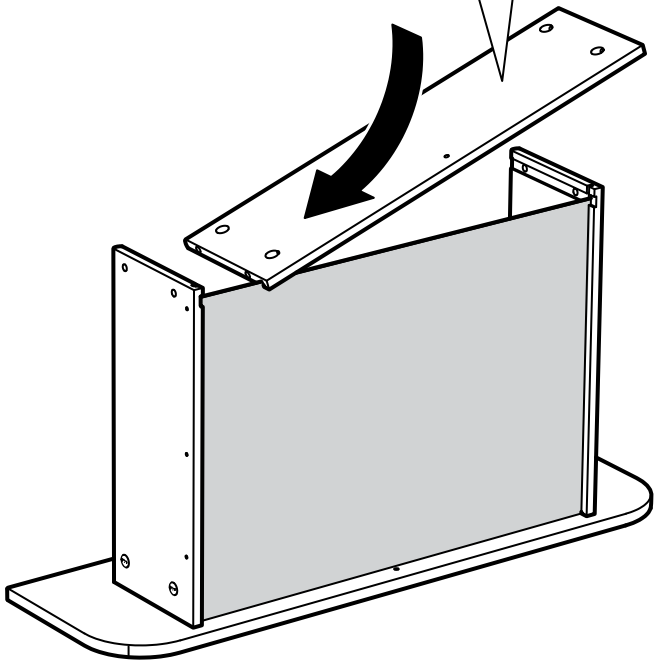
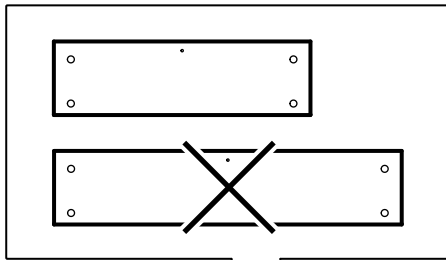

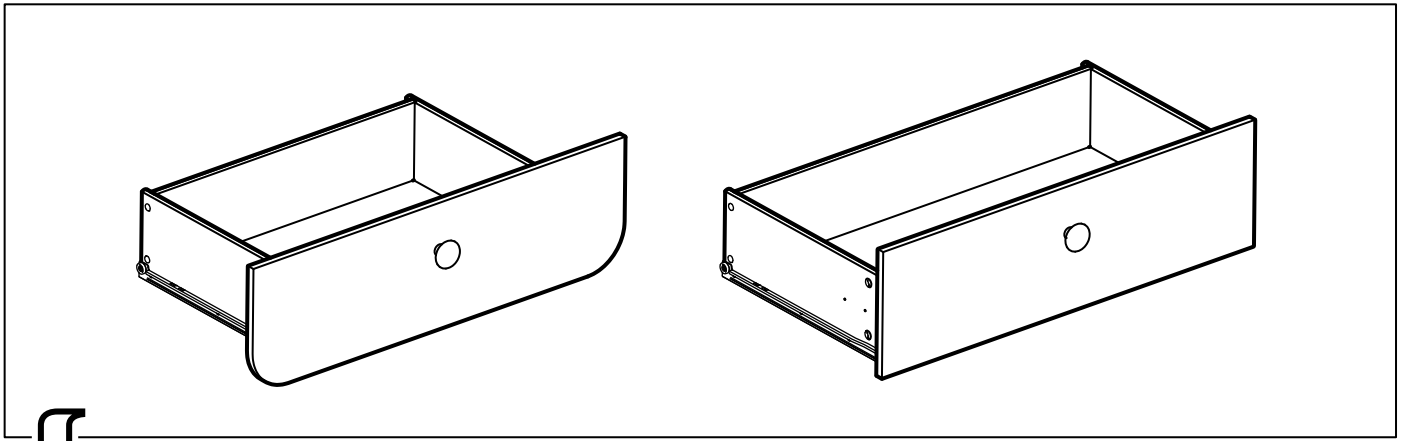

55

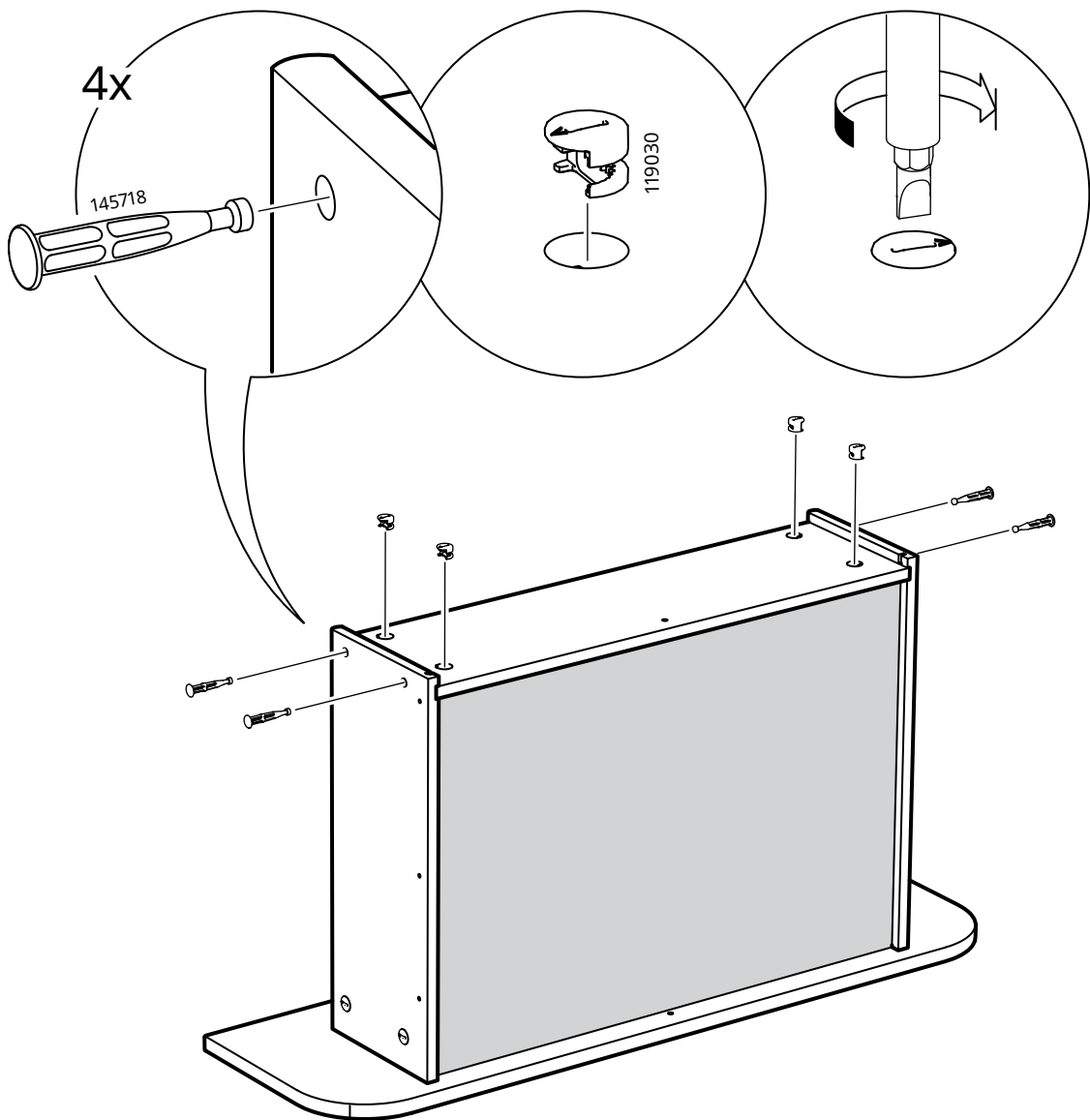

56

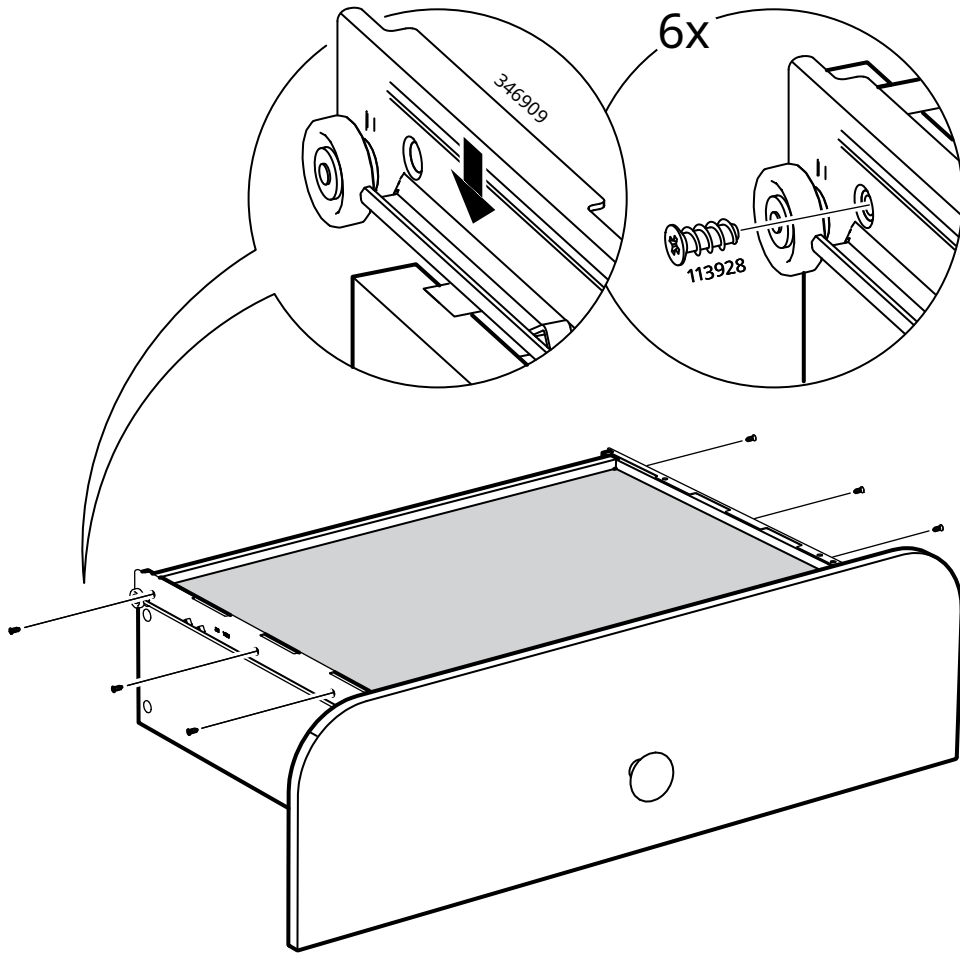

57

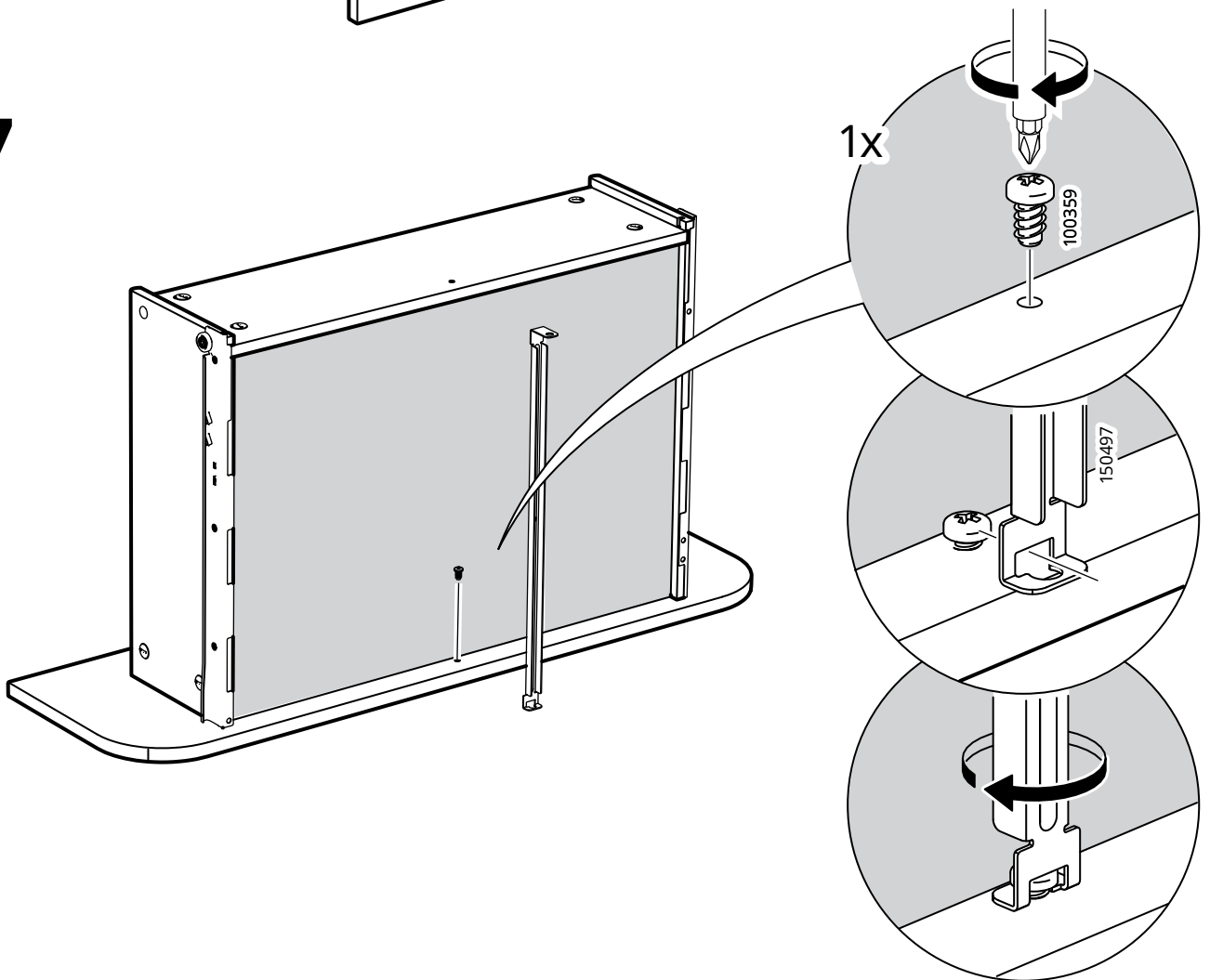

58

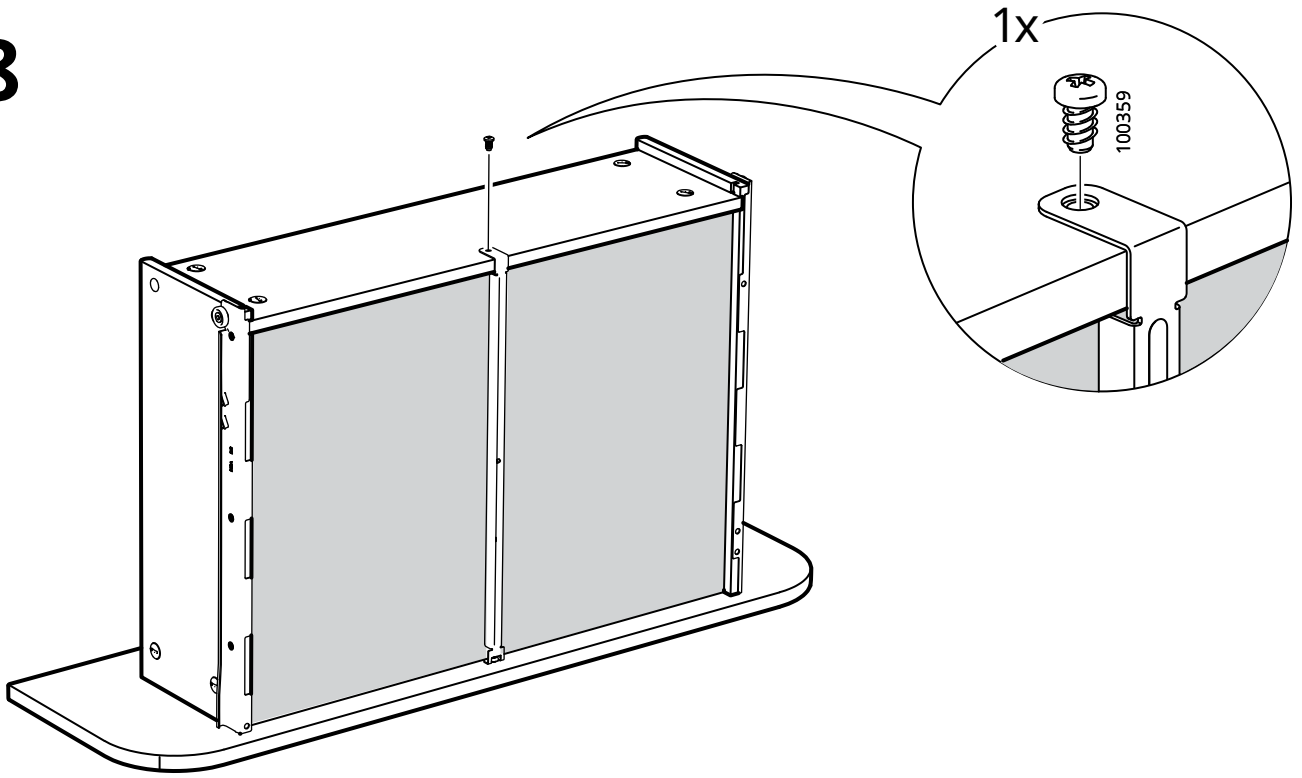

59

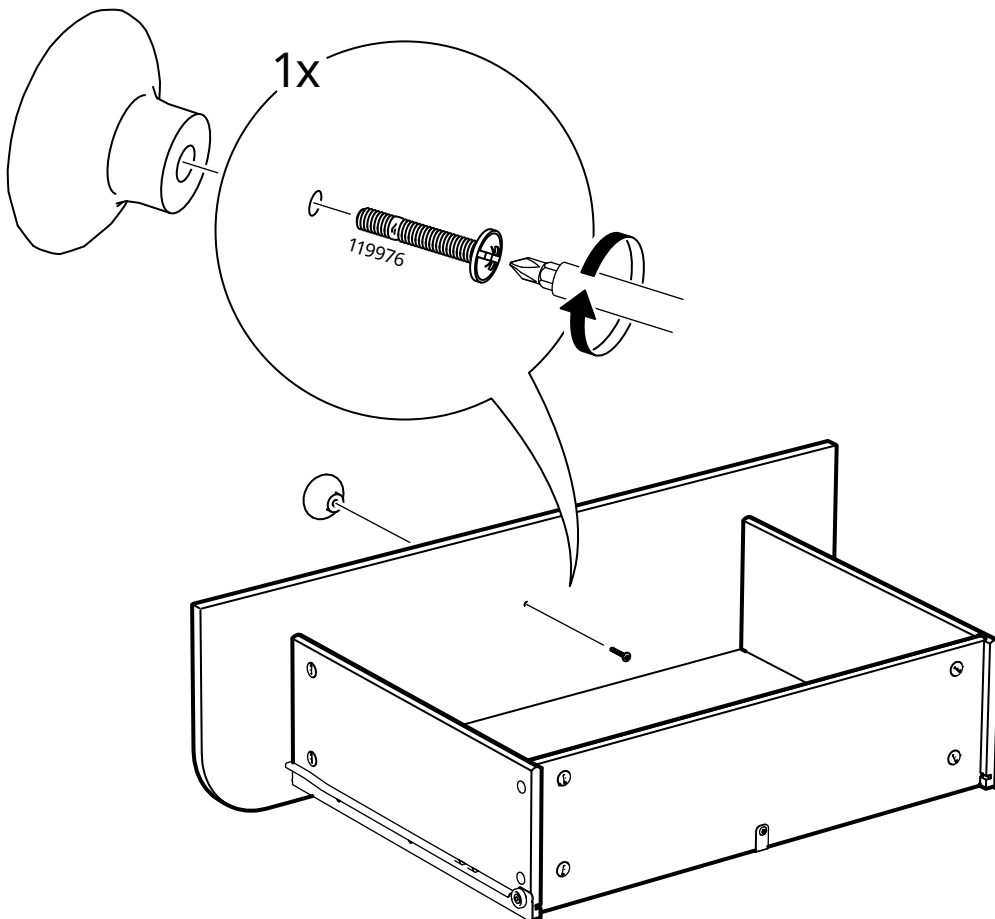

60

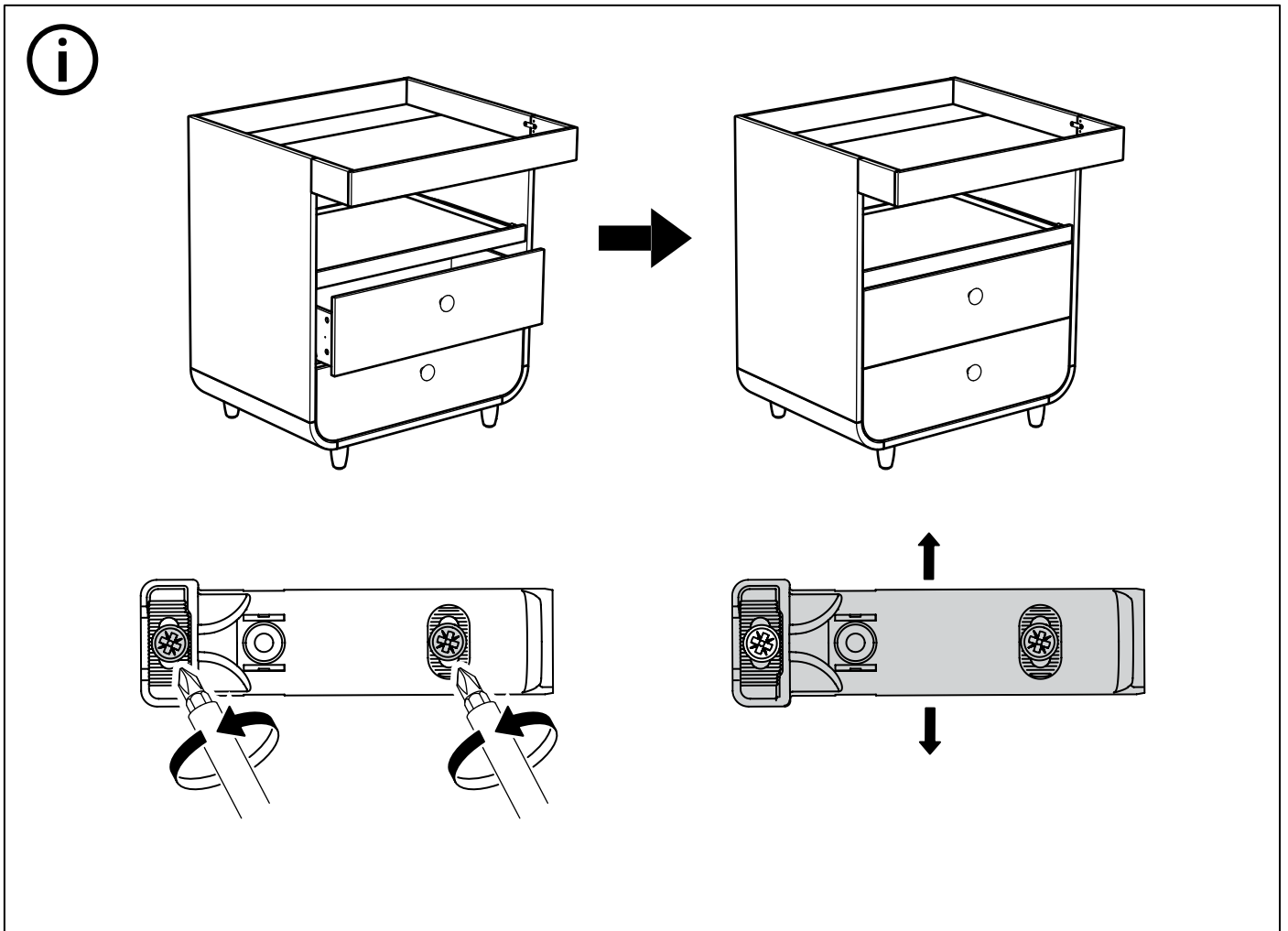
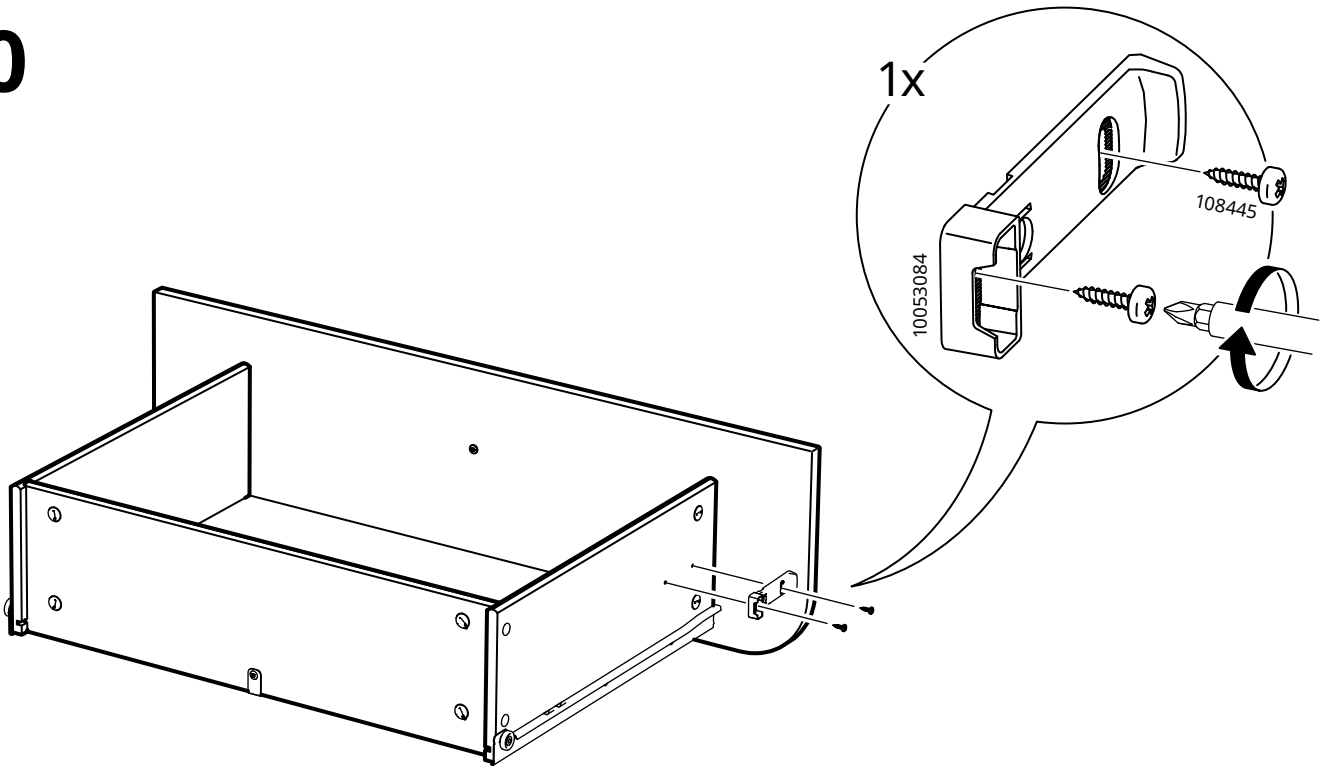

61

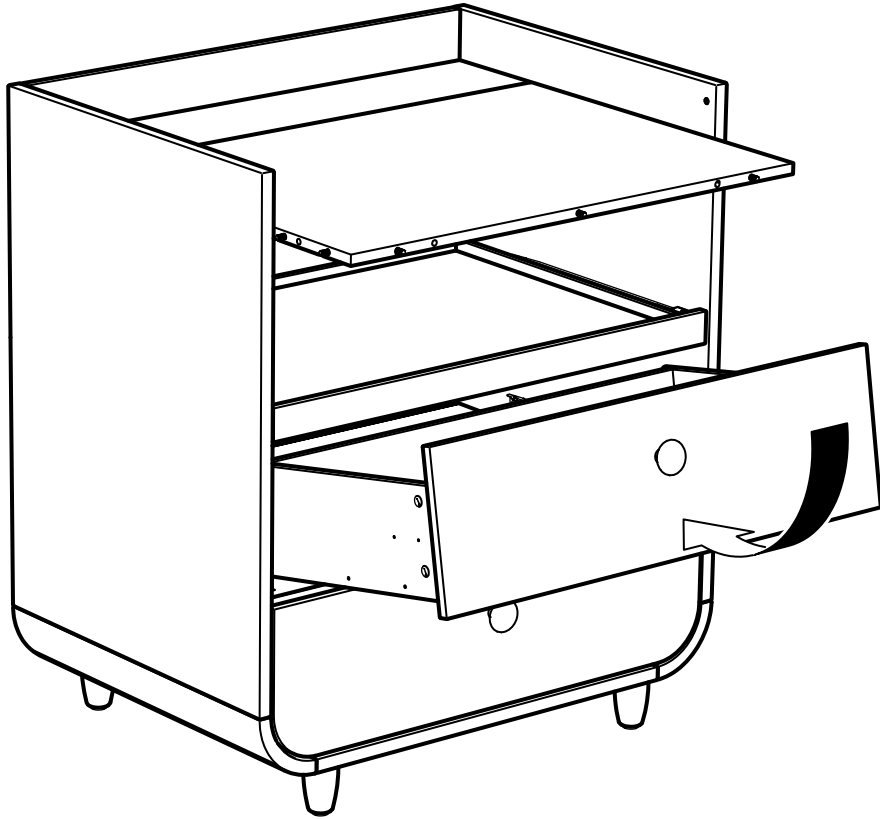

62

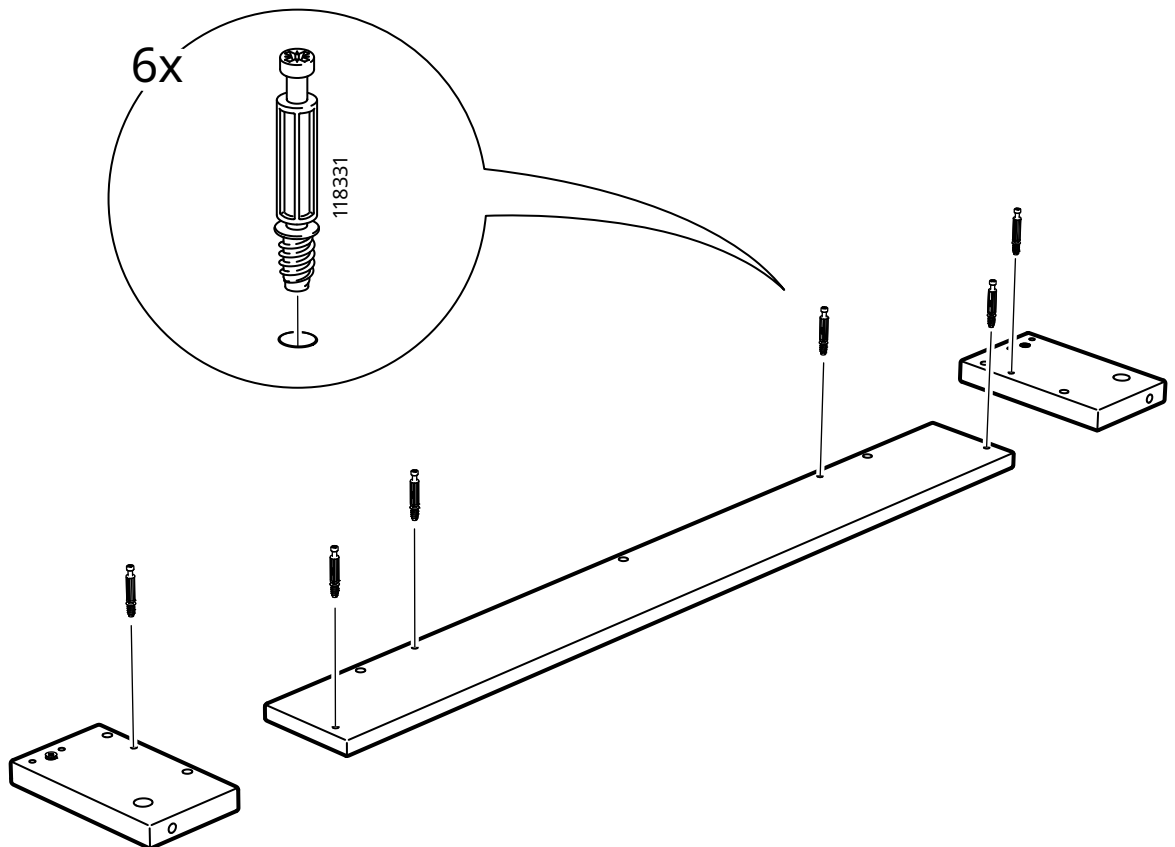

63

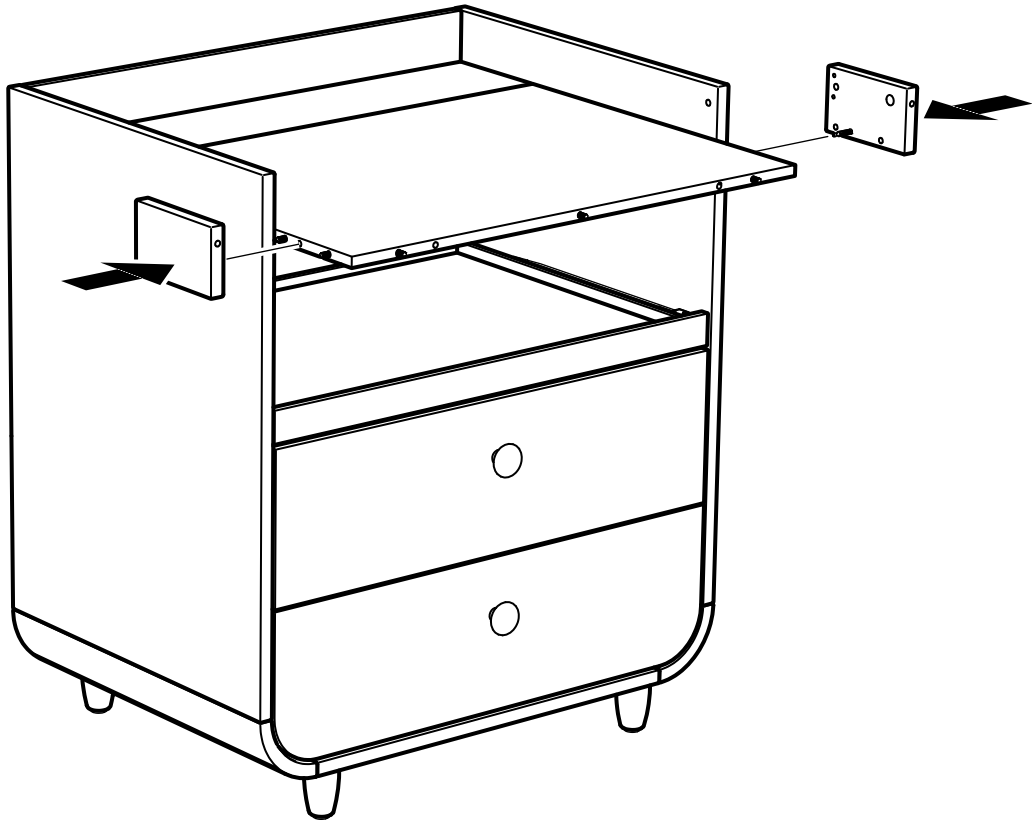

64

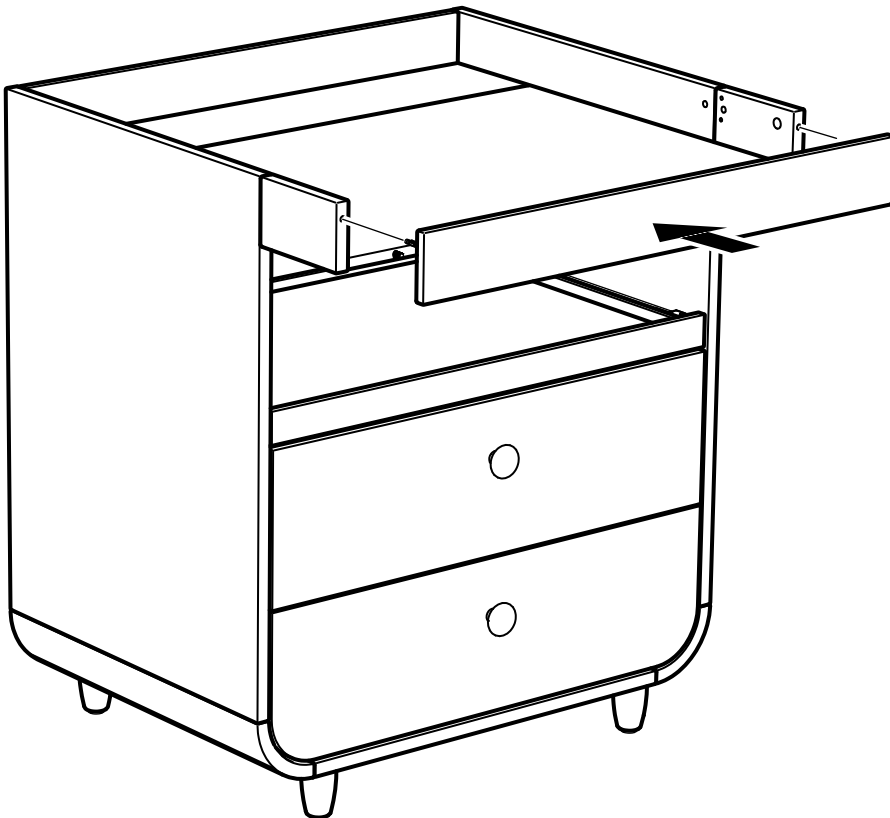

65

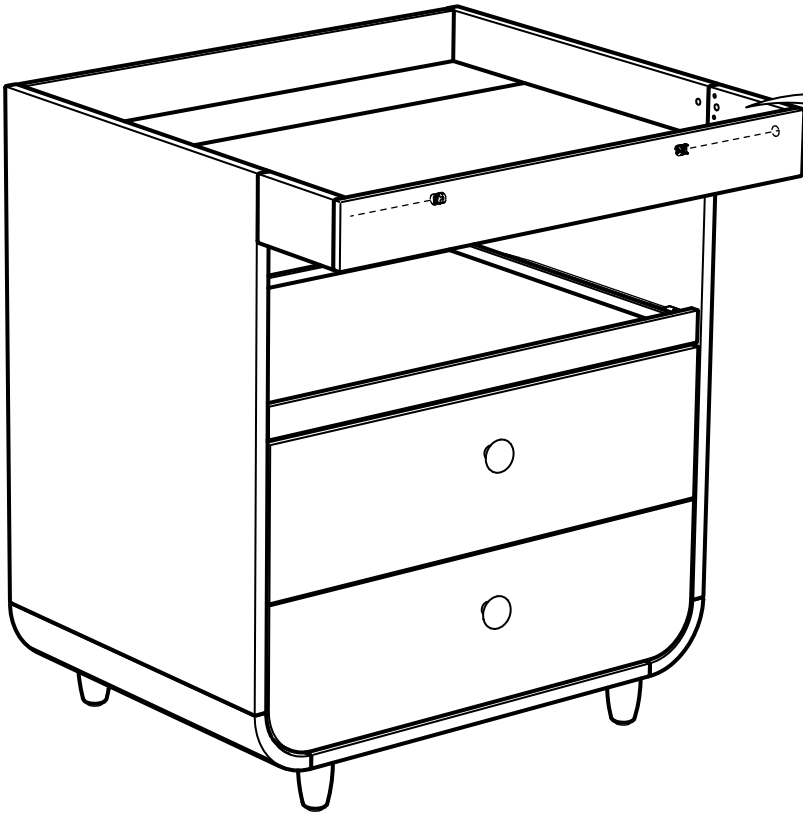
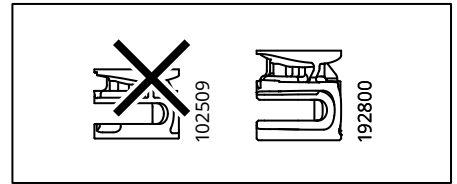

2x

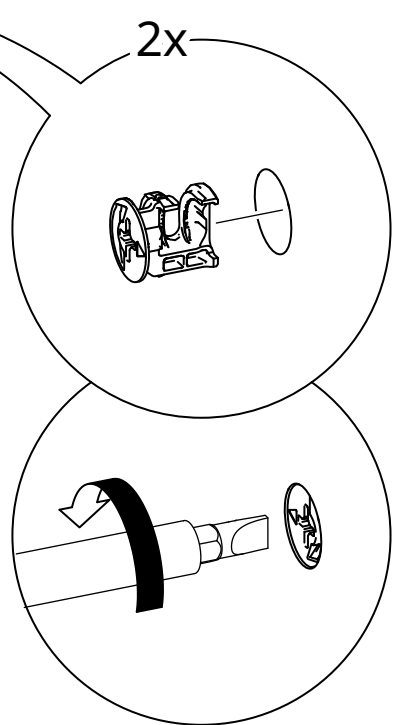

66

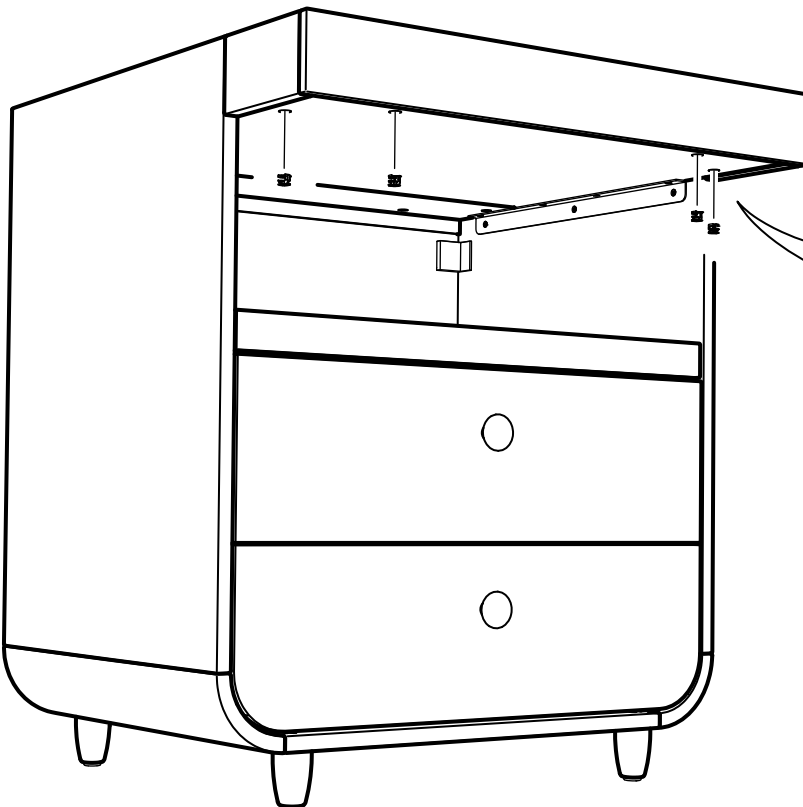
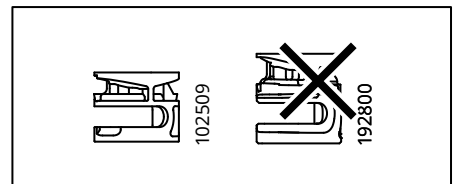

4x

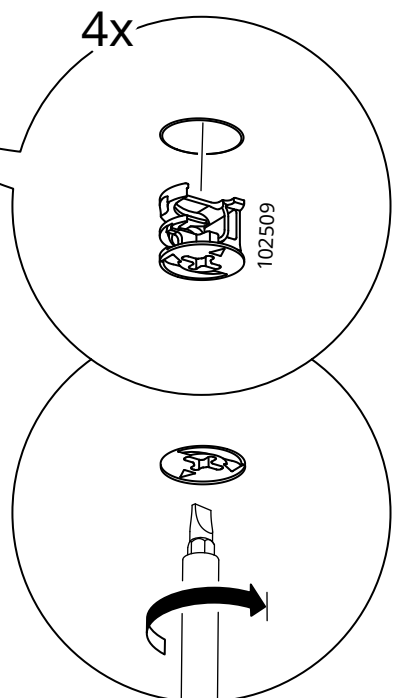

67

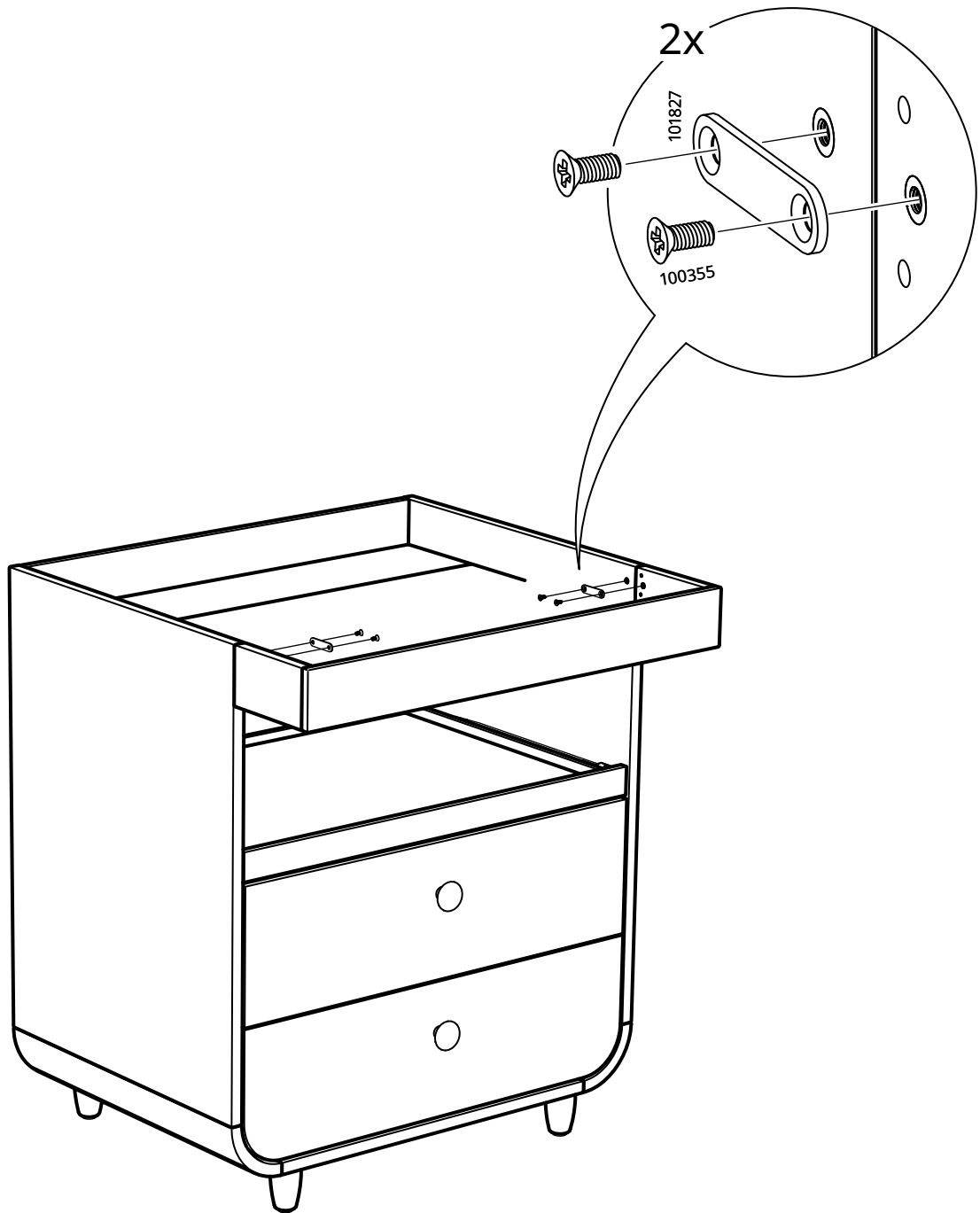

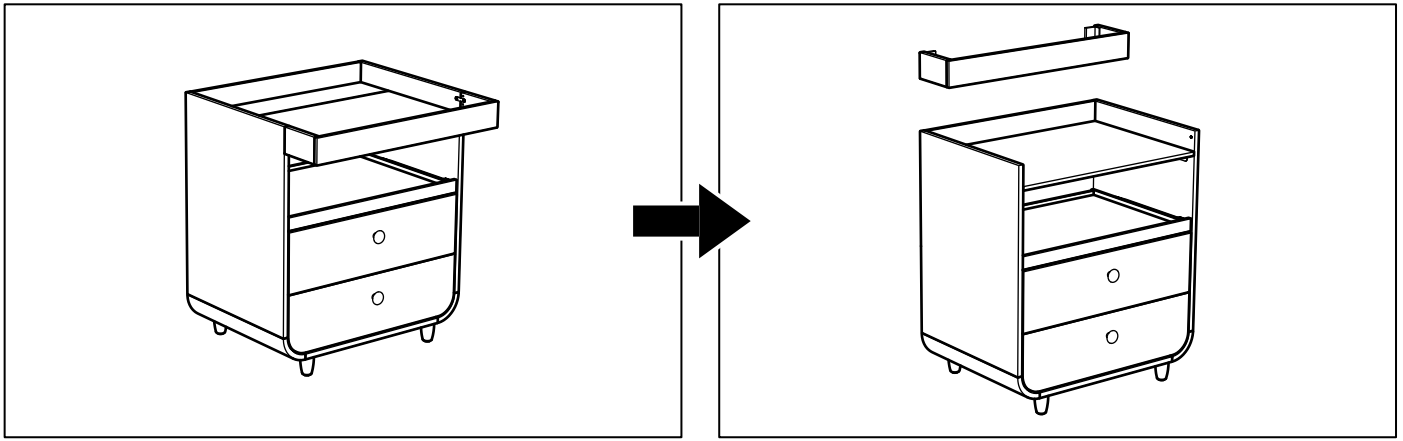

1

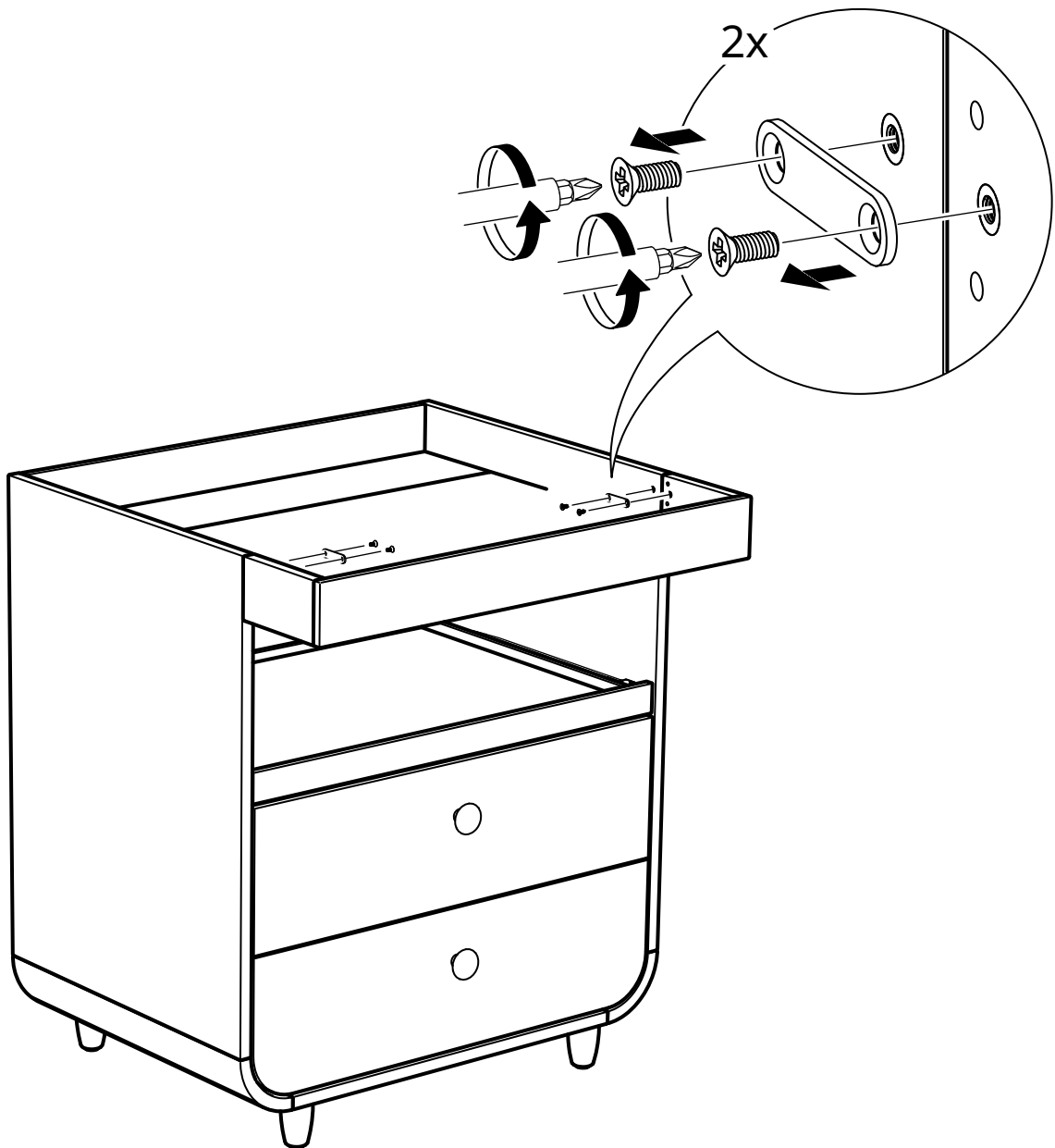

2

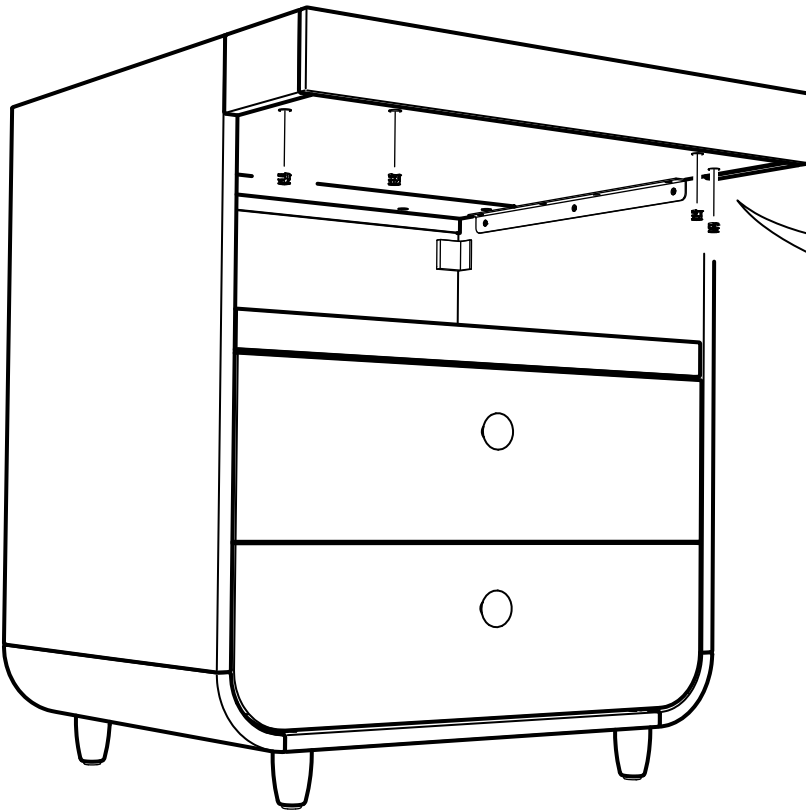

4x

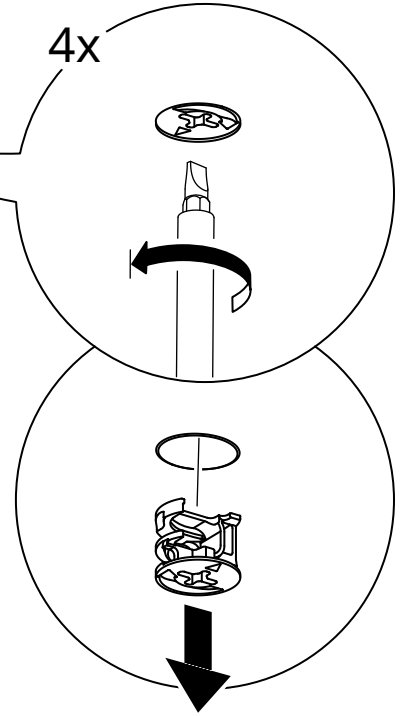

3

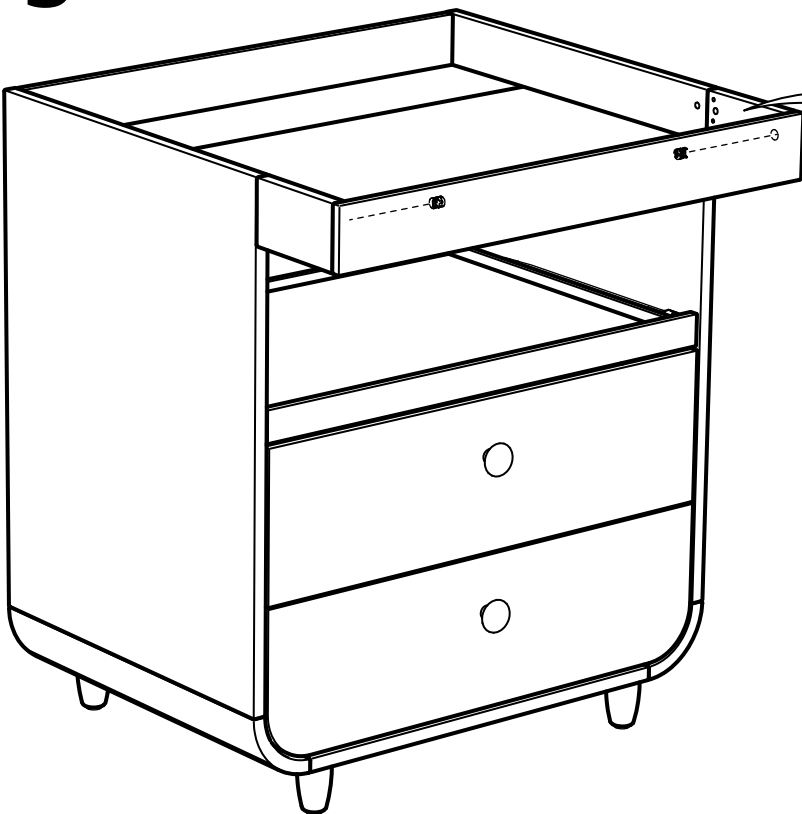

2x

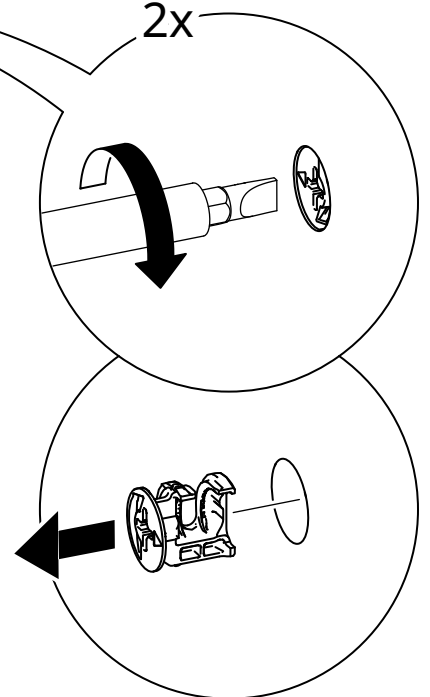

4

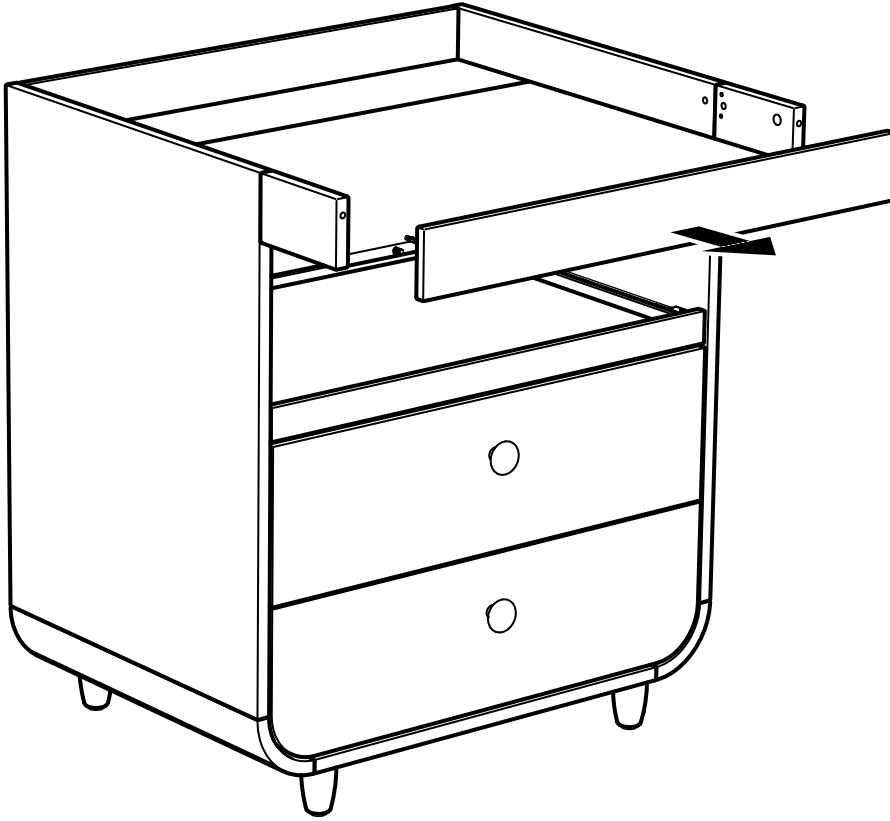

5

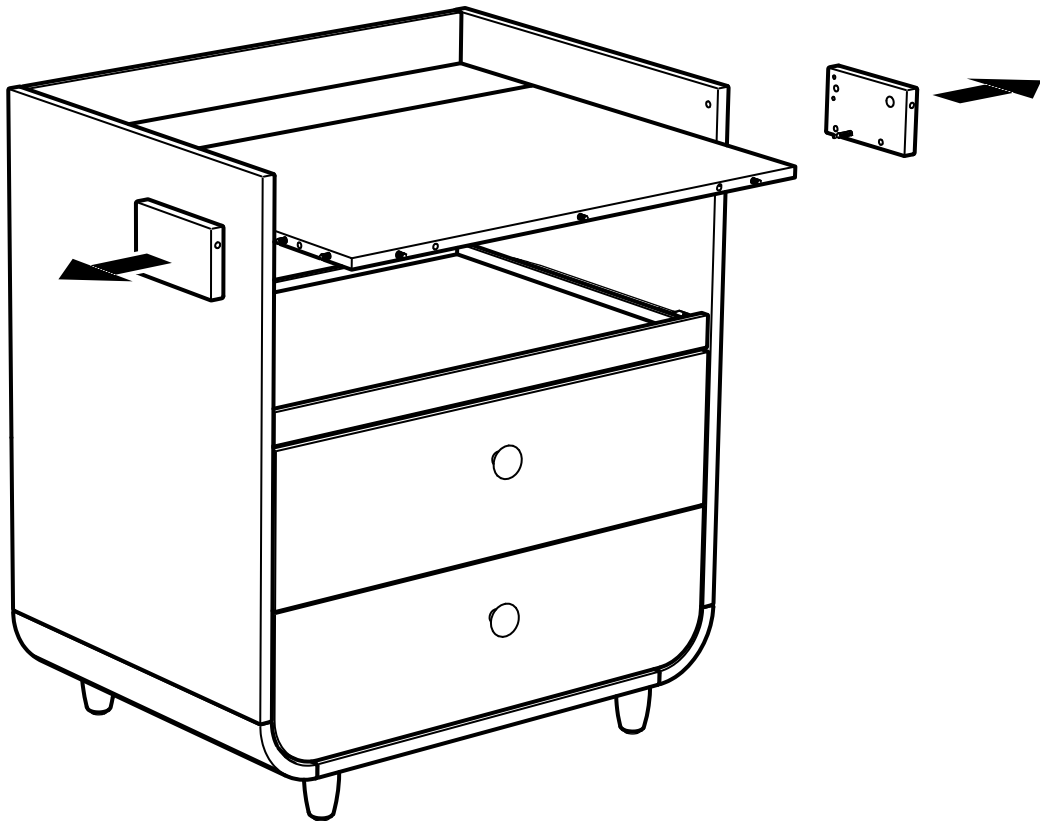

6

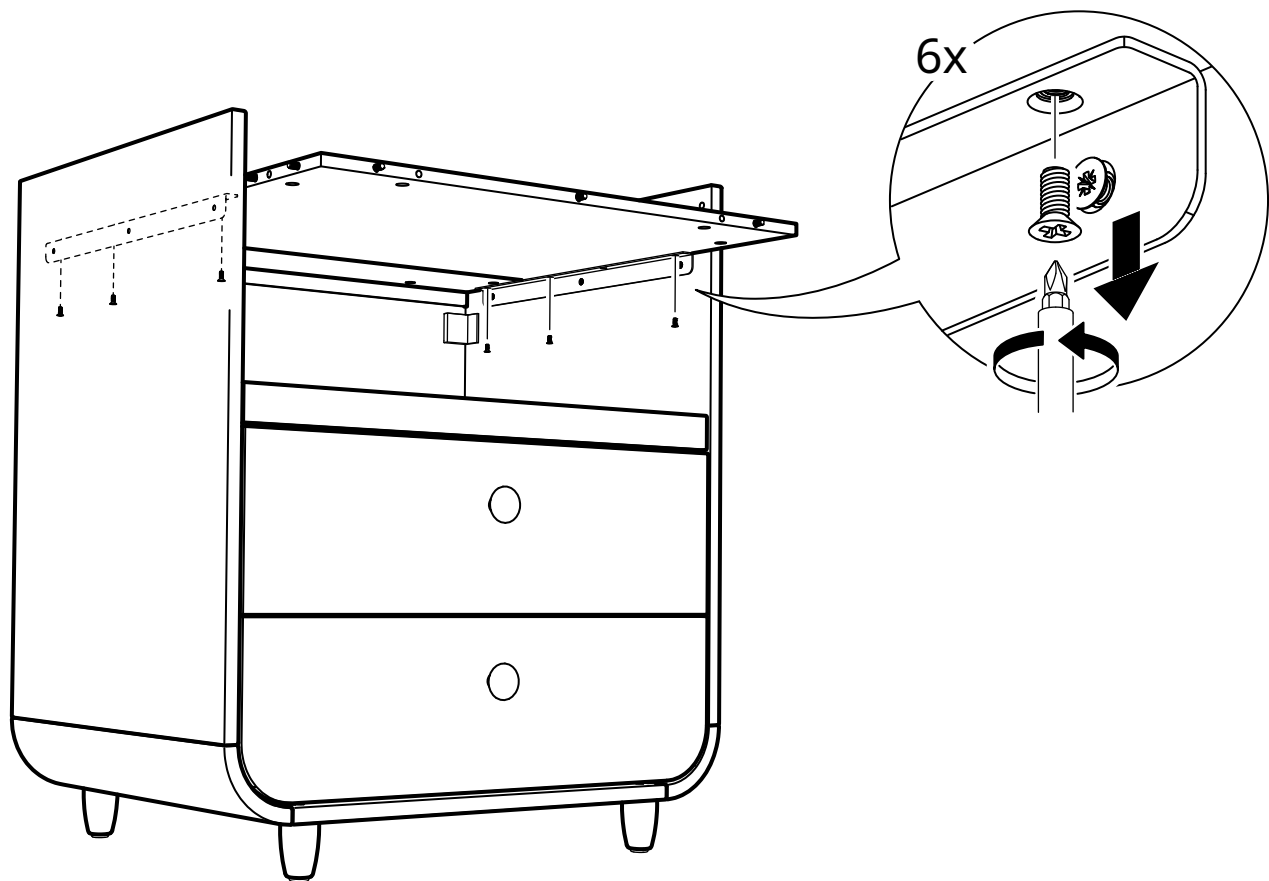

7

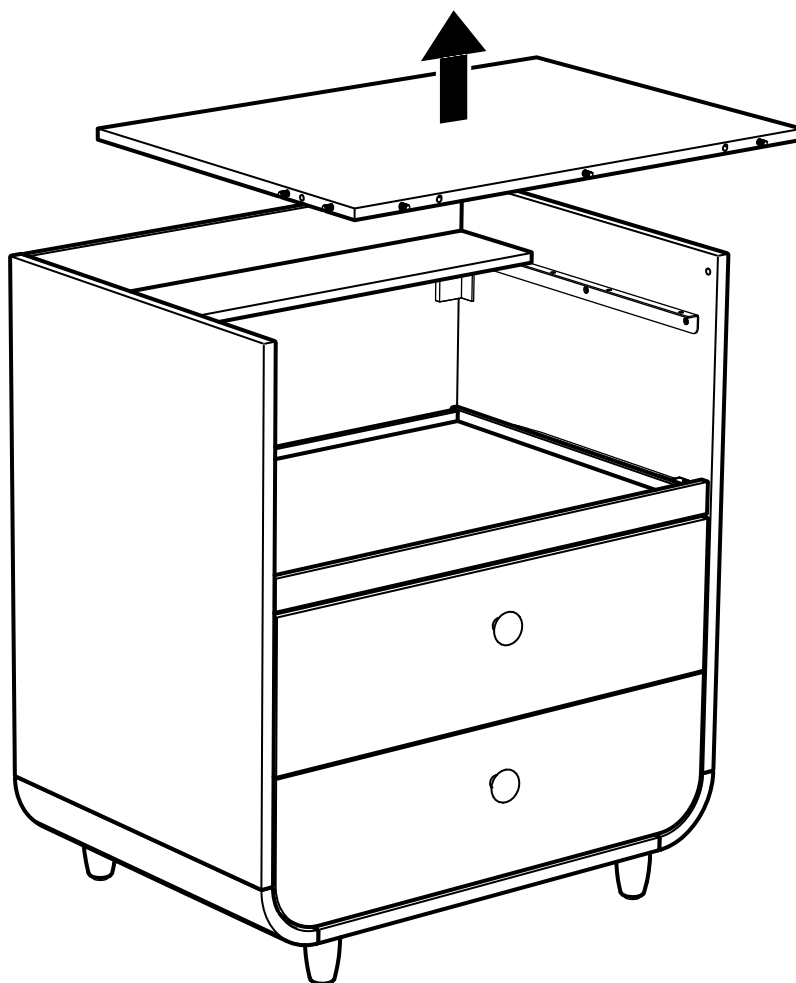

8

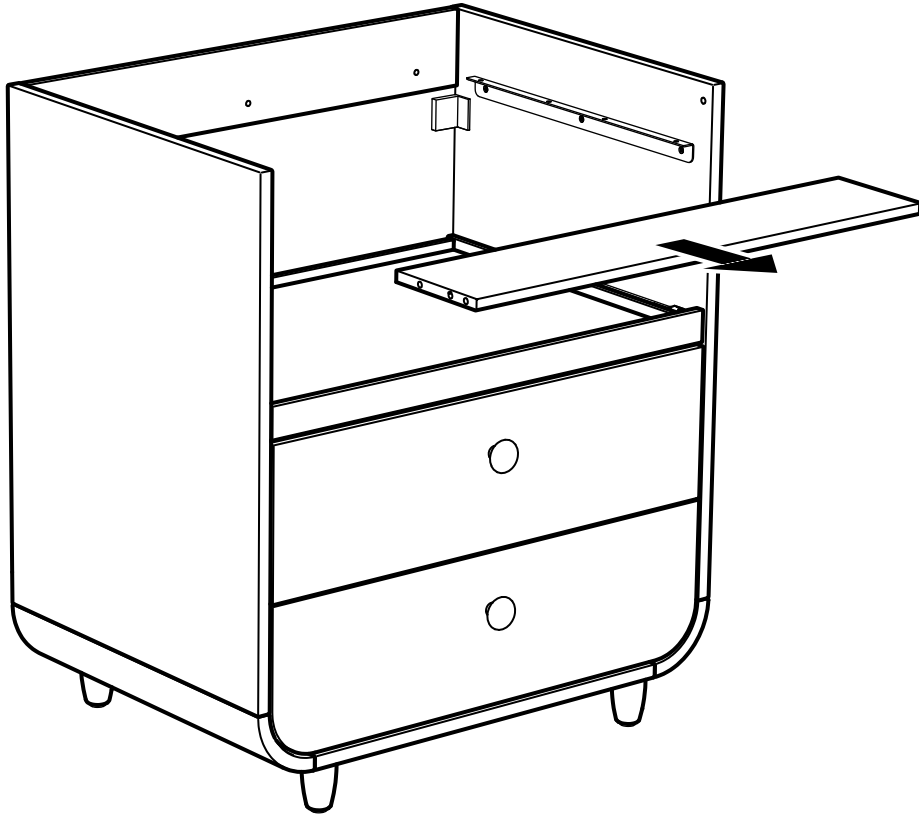

9

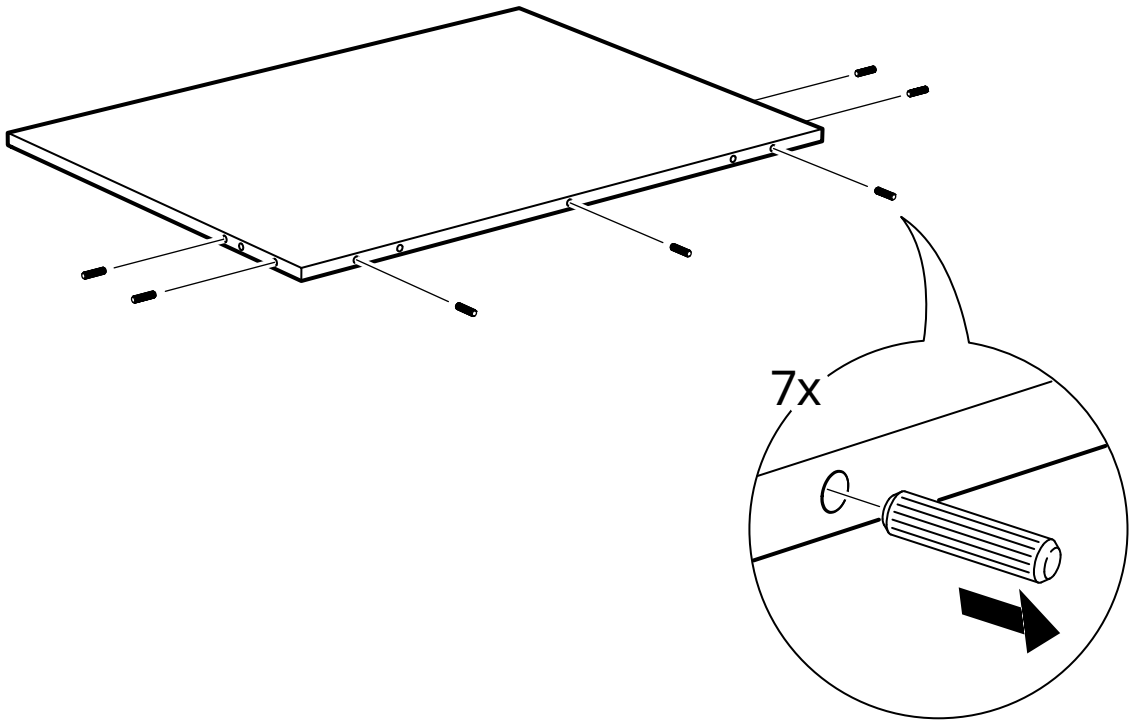

10

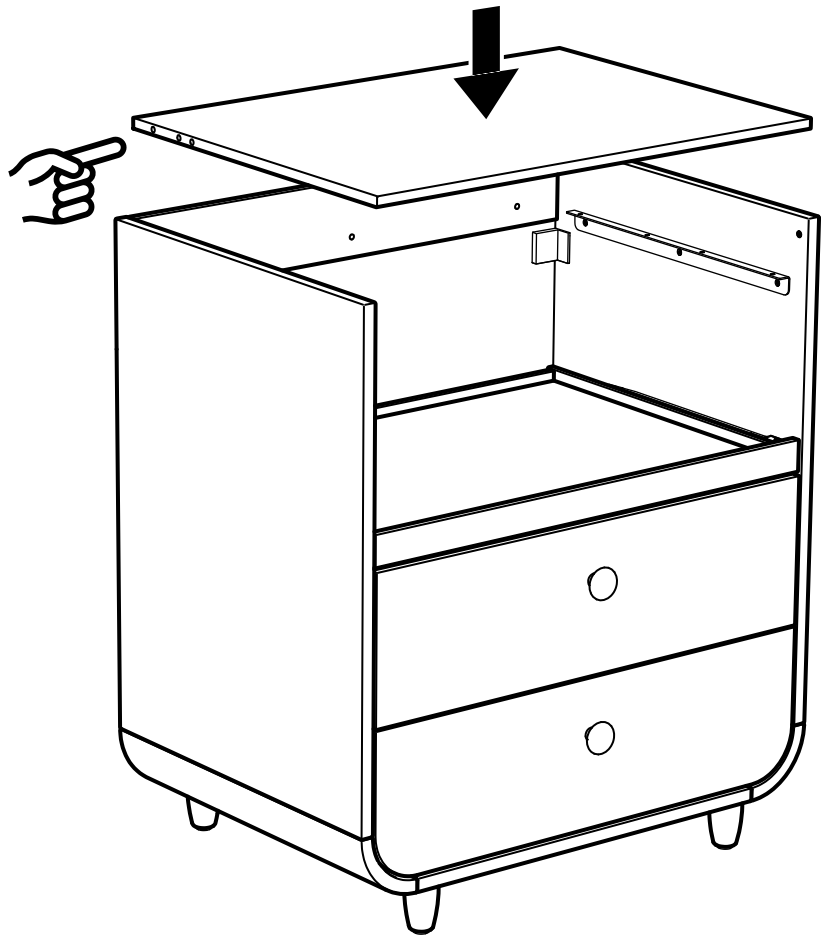
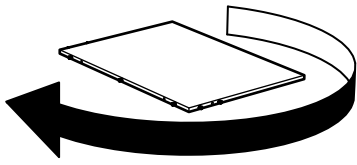

11

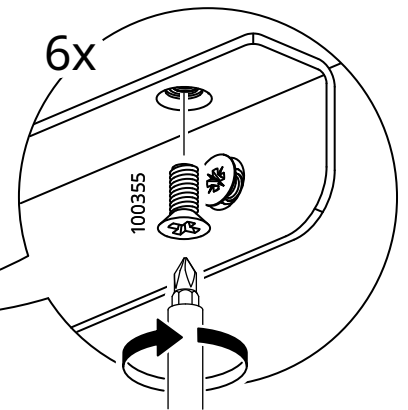
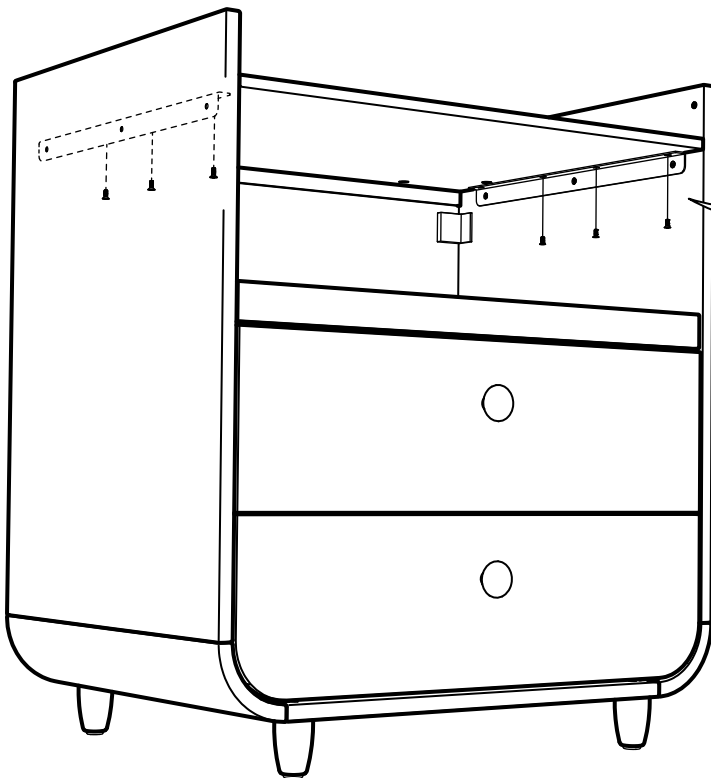

12

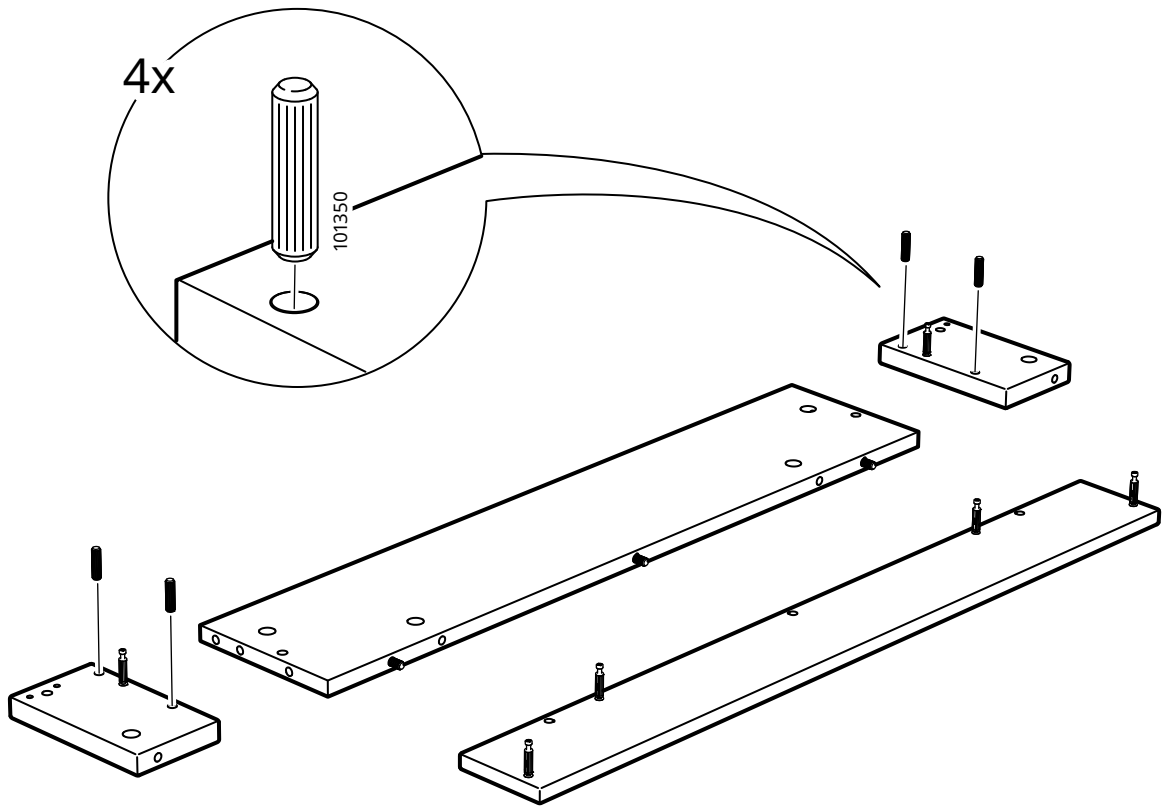

13

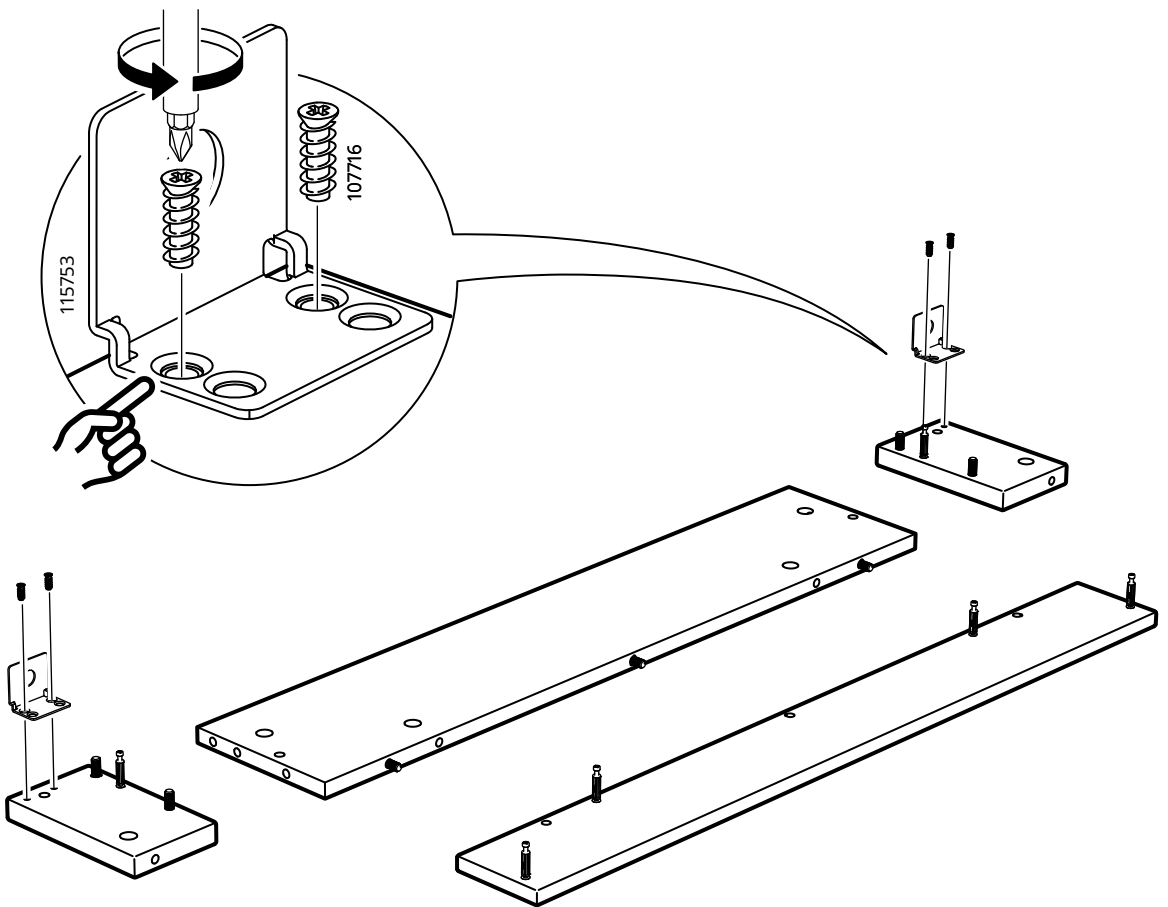

14

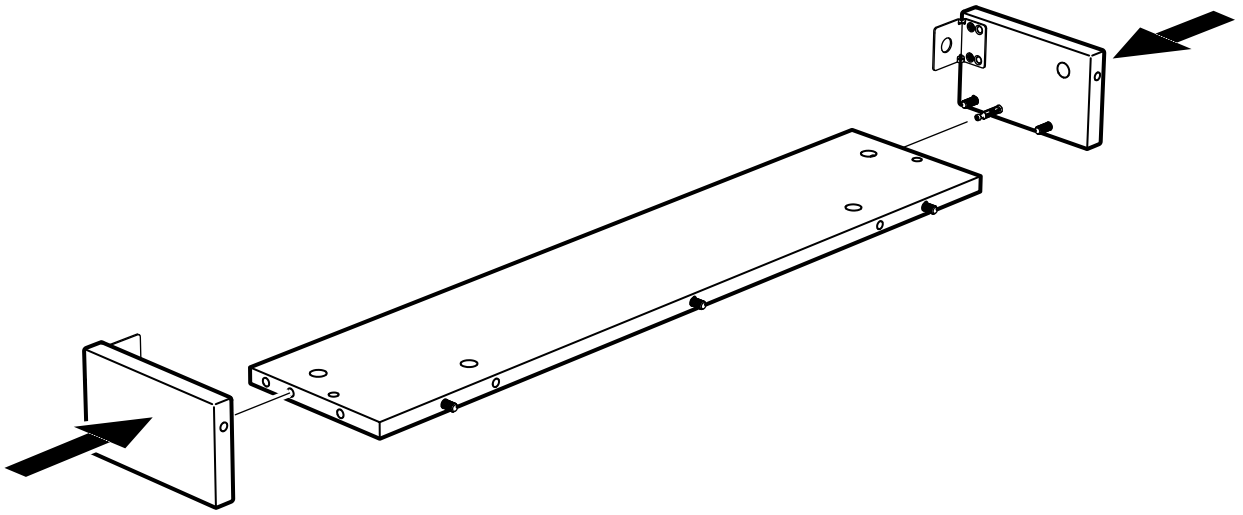

15

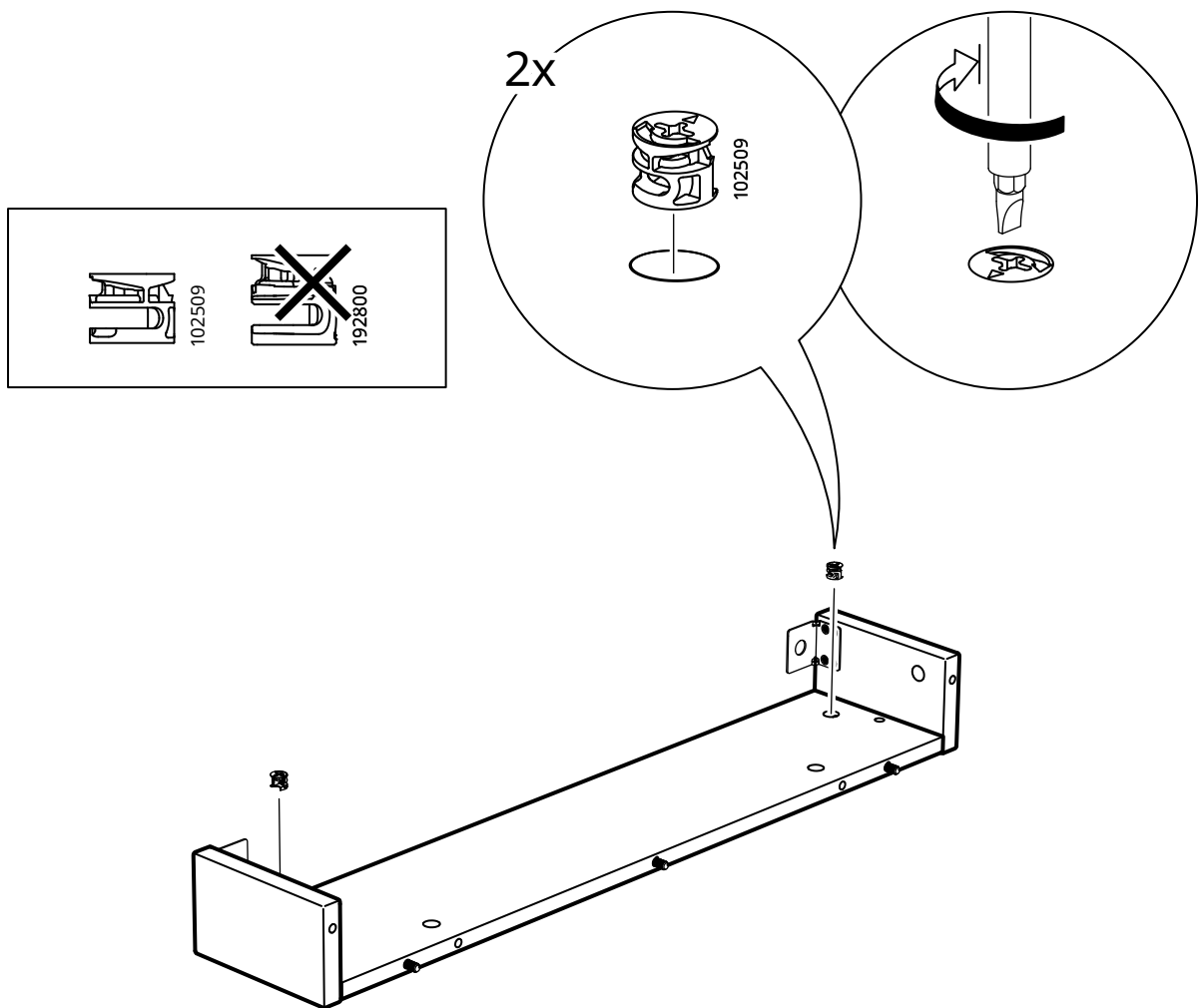

16

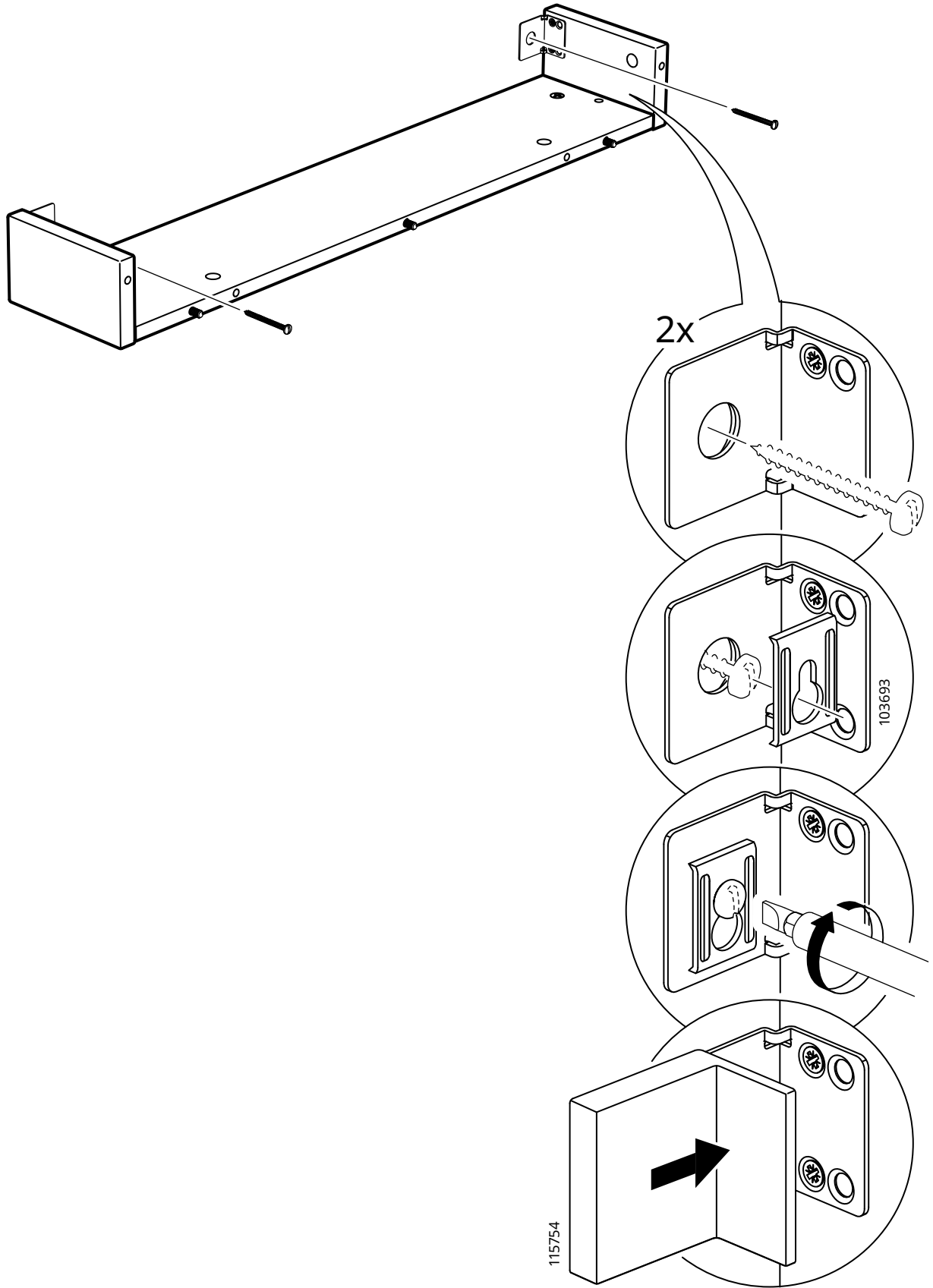

17

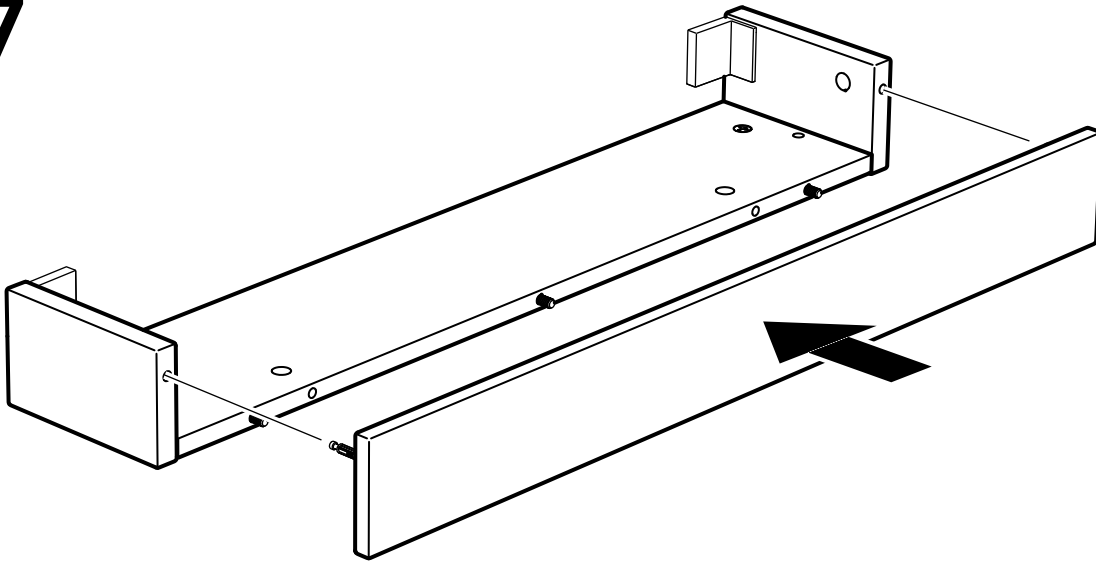

18

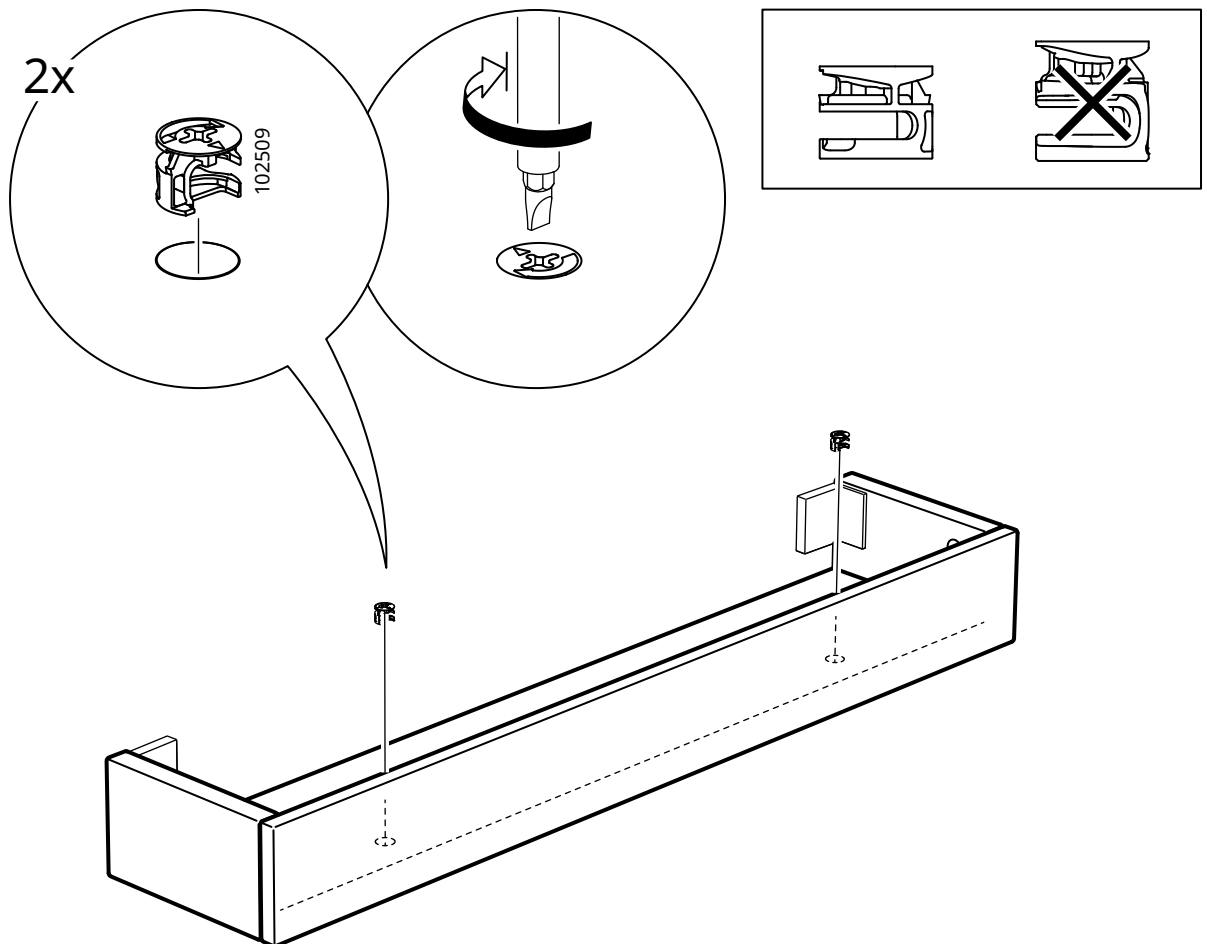

19

