

# SONGESAND

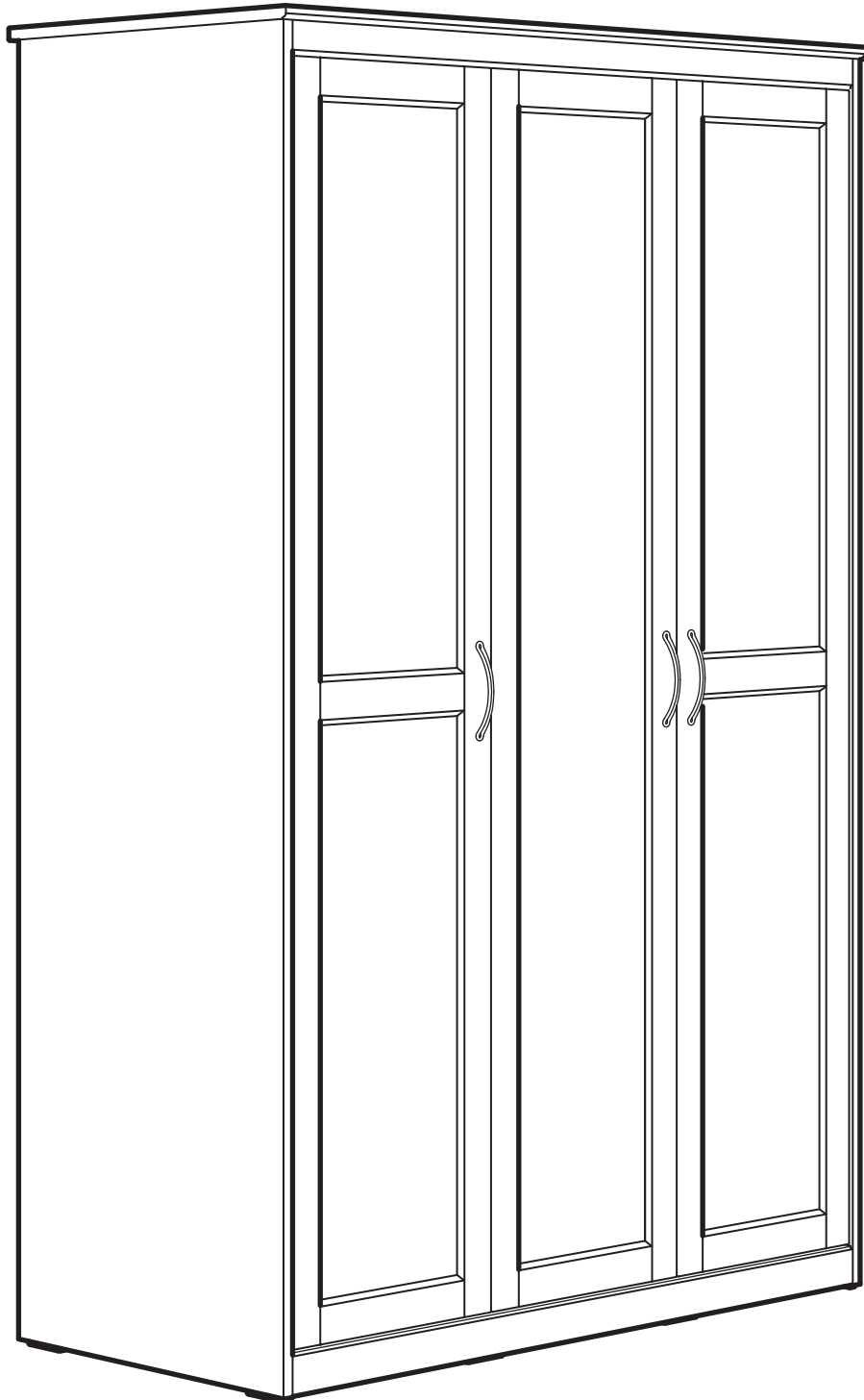

Design and Quality  
IKEA of Sweden



Español

## ADVERTENCIA:

Si el mueble volcase, podría provocar lesiones graves e incluso mortales. Para limitar el riesgo de vuelco de los muebles:

**Fija SIEMPRE el mueble a la pared con herrajes antivuelco.**

**Para reducir más el riesgo de daños graves o mortales por el vuelco del mueble:**

Coloca los objetos más pesados en el cajón inferior.

No pongas la televisión u otros objetos pesados en la parte superior del mueble.

Nunca permitas que los niños trepen o se cuelguen de los cajones, baldas o puertas.

Lee y sigue cada paso de las instrucciones cuidadosamente.

Català

## ATENCIÓ!

Si el moble bolca, pot provocar lesions greus o la mort. Per reduir el risc que un moble bolqui:

**Colla SEMPRE el moble a la paret amb ferramentes antibolcada.**

**Per reduir encara més el risc de danys greus o mortals:**

Posa els objectes més pesants al calaix inferior.

No posis un televisor o altres objectes pesants en la part de dalt del moble.

No deixis que els infants s'enfilin o es penguin dels calaixos, les lleixes o les portes.

Llegeix i segueix atentament els passos de les instruccions.

Euskara

## KONTUZ!

Altzaria iraultzen bada, lesio oso larriak edo heriotza izan daitezke ondorioak. Altzarien iraulteta-arriskua mugatzeko:

**Finkatu BETI altzariak horman ez iraultzeko burdinkien bidez.**

**Altzaria iraultzeagatik lesio larriak edo heriotza-lesioak izateko arriskua are gehiago murrizteko:**

Jarri gehien pisatzen duten objektuak beheko tiraderan.

Ez jarri telebista edo bestelako objektu astunak altzariaren goiko aldean.

Ez utzi inoiz hurrei tiradera, ate edo apaletan gora egiten edo horietatik zintzilikatzen.

Irakurri eta jarraitu argibideetako urrats bakoitza kontu handiz.

Galego

## ADVERTENCIA

A envorcadura dun moble pode provocar lesións moi graves e mesmo mortais. Para reducir os riscos de envorcadura:

**Fixar SEMPRE este moble á parede utilizando os accesorios antienvorcadura.**

**Para reducir aínda máis o risco de que se produzan lesións graves ou mesmo mortais:**

Colocar os obxectos máis pesados no caixón inferior.

Non colocar un televisor nin ningún outro obxecto pesado enriba deste produto.

Evitar que as crianzas suban enriba do moble ou se colguen dos caixóns, portas ou estantes.

Ler e seguir atentamente as instrucións.







Español

**ADVERTENCIA:**

Si el mueble volcase podría provocar lesiones graves e incluso mortales. Para limitar el riesgo de vuelco de los muebles:

Fija **SIEMPRE** el mueble a la pared con herrajes antivuelco.

Para reducir más el riesgo de daños graves o mortales por el vuelco del mueble:

Coloca los objetos más pesados en el cajón inferior.

No pongas la televisión u otros objetos pesados en la parte superior del mueble.

Nunca permitas que los niños trepen o se cuelguen de los cajones, baldas o puertas.

Lee y sigue cada paso de las instrucciones cuidadosamente.

Català

**ATENCIÓ!**

Si el mueble bolca, pot provocar lesions greus o la mort. Per reduir el risc que un mueble bolqui:

Colla **SEMPRE** el mueble a la paret amb ferramentes antibolcada.

Per reduir encara més el risc de danys greus o mortals:

Posa els objectes més pesants al calaix inferior.

No posis un televisor o altres objectes pesants en la part de dalt del mueble.

No deixis que els infants s'enfilin o es pengin dels calaixos, les lleixes o les portes.

Llegeix i segueix atentament els passos de les instruccions.

Euskara

**KONTUZ!**

Altzaria iraultzen bada, lesio oso larriak eta heriotza izan daitezke ondo iraultzean. Iraultze-arriskua mugatzeko:

Finkatu **BETI** altzariak horman ez iraultzeko burdinkien bidez.

Altzaria iraultzeagatik lesio larriak eta heriotza-lesioak izateko arriskua are gehiago guturrizteko:

Jarri gehien pisatzen duten objektuak beheko tiraderan.

Ez jarri telebista edo bestelako objektu astunak altzariaren goiko aldean.

Ez utzi inoiz haurrei tiradera, ate edo apaletan gora egiten edo horietatik zintzilikatzen.

Irakurri eta jarraitu argibideetako urrats bakoitza kontu handiz.

Galego

**ADVERTENCIA**

A enforcadura dun mueble pode provocar lesións moi graves e mesmo mortais. Para reducir os riscos de enforcadura:

Fixar **SEMPRE** este mueble á parede utilizando os accesorios antienvorcadura.

Para reducir aínda máis o risco de que se produzan lesións graves ou mesmo mortais:

Colocar os obxectos máis pesados no caixón inferior.



Non colocar un televisor nin ningún outro obxecto pesado enriba deste produto.

Evitar que as criancas suban encima do mueble ou se colguen dos cajóns, portas ou estantes.

Leer e seguir atentamente as instrucións.

Ø 5/16" (8 mm) Ø 1/8" (3 mm)

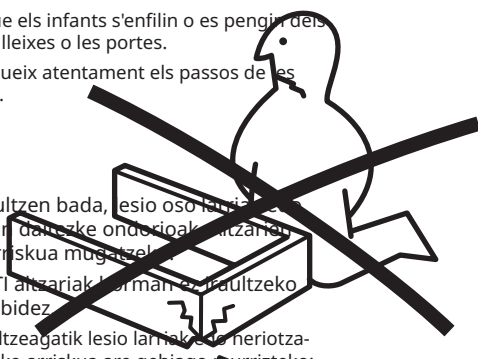
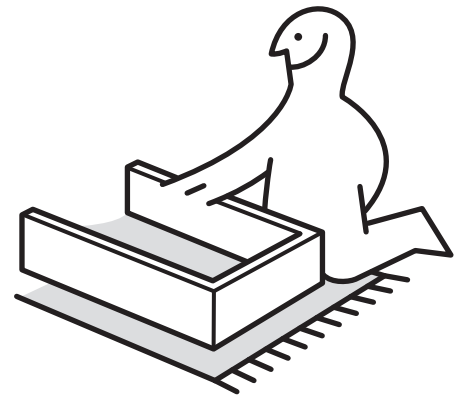
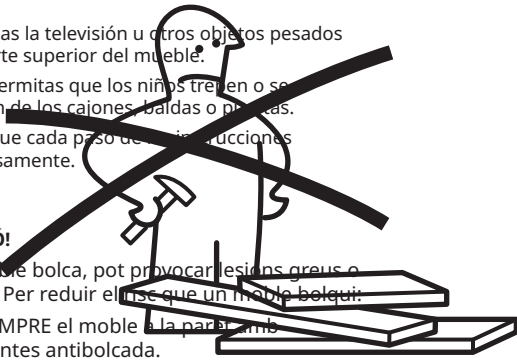
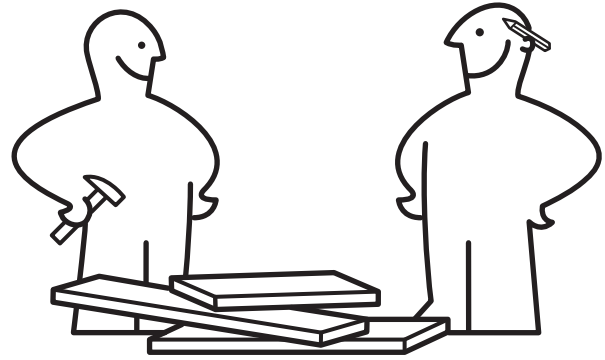

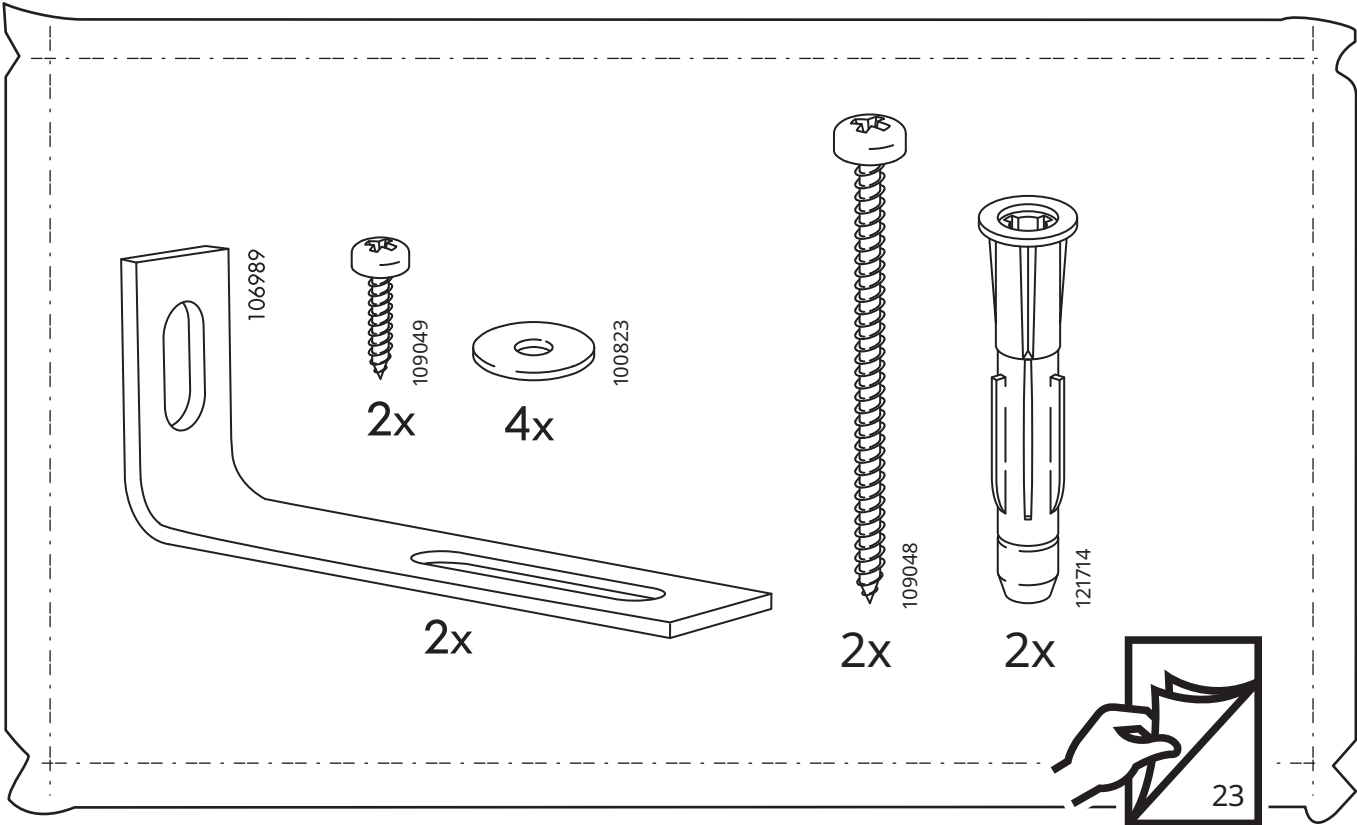
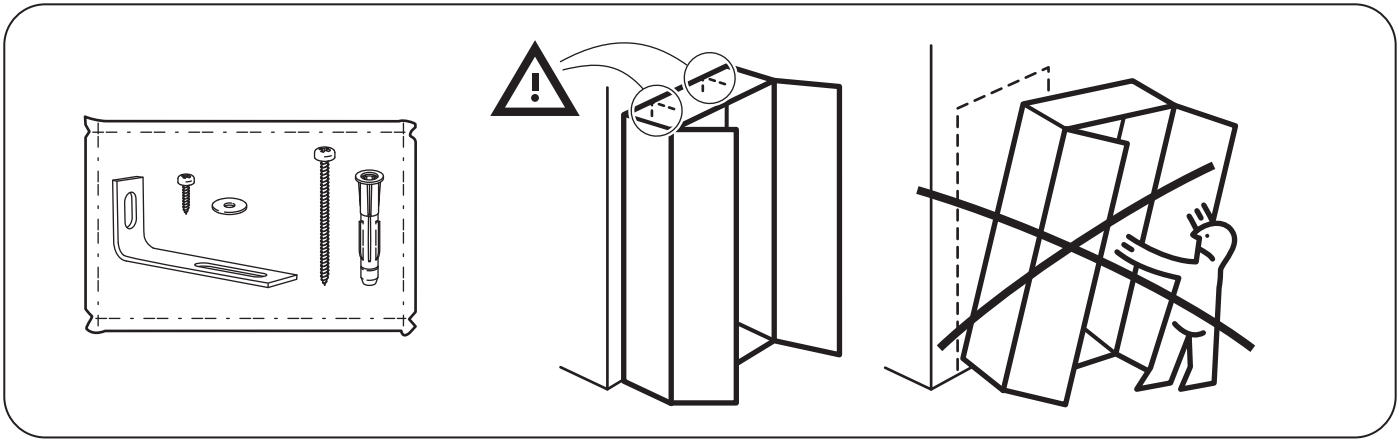

326949

# 1

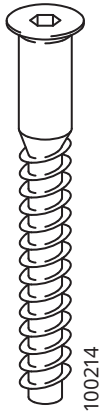

10x

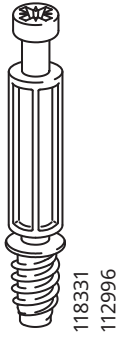

20x



4x



20x



22x

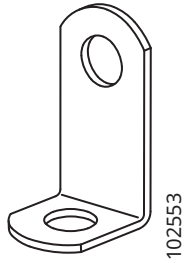

2x

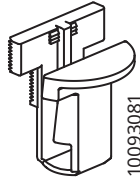

20x



20x

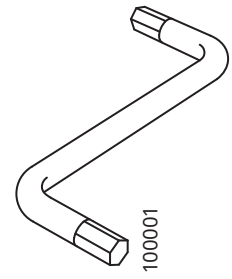

1x

# 2

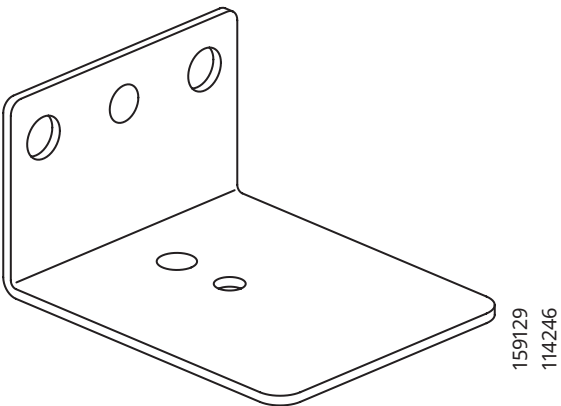

1x

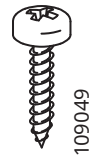

5x

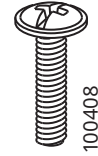

6x



42x

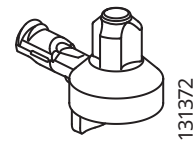

12x

**3**

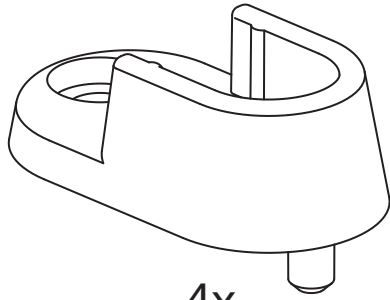

4x

157307  
157306



105811

4x



115339

6x

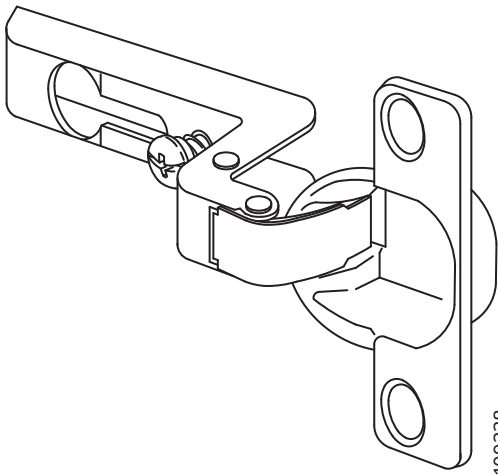

10x

109338

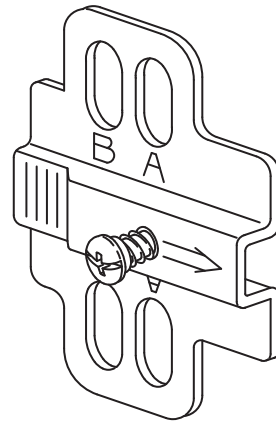

10x

109221

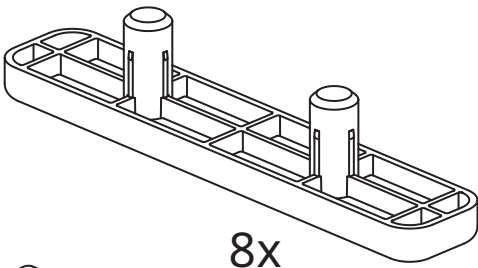

8x

158568  
153548

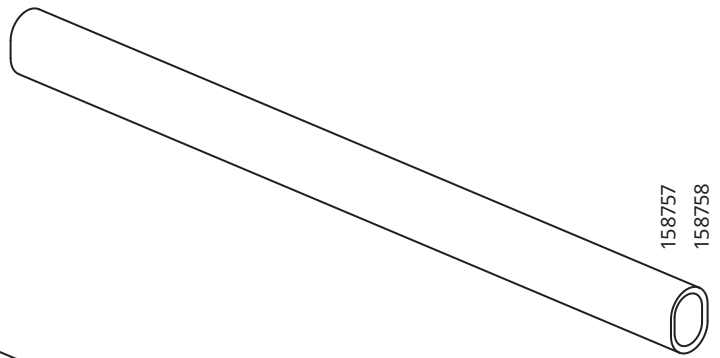

158757  
158758

1x

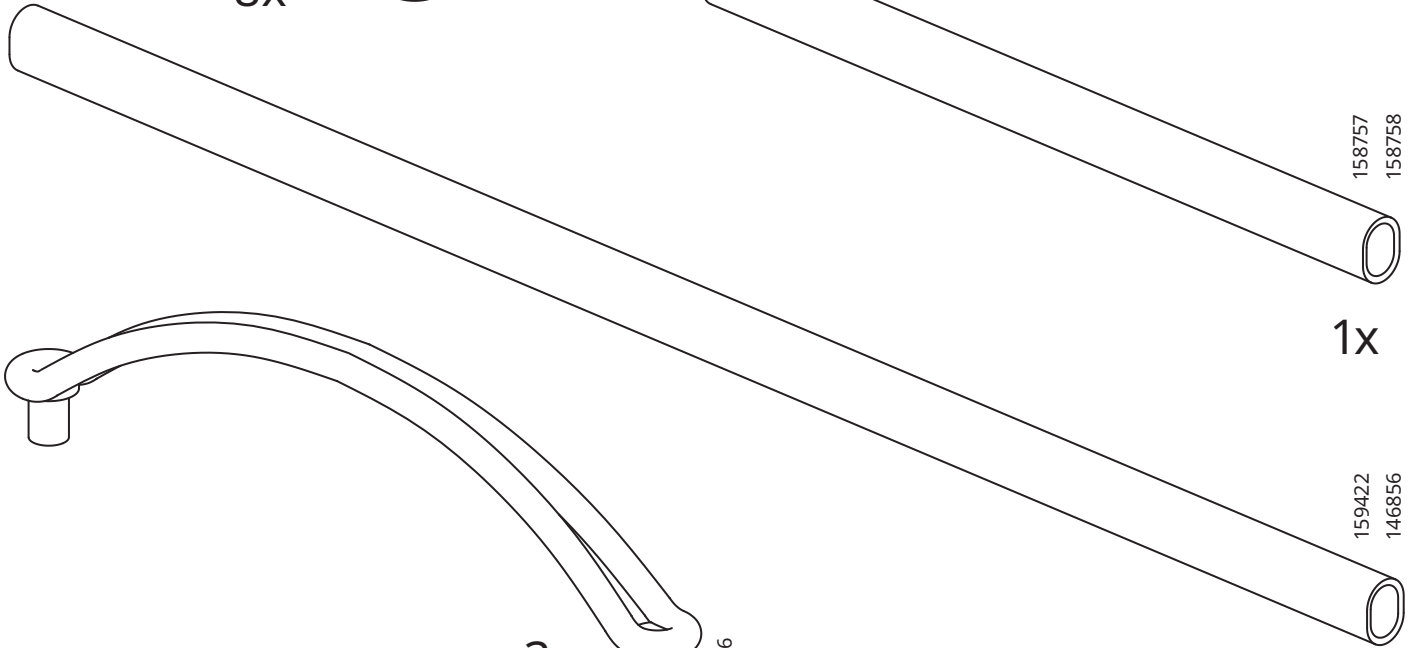

159422  
146856

1x

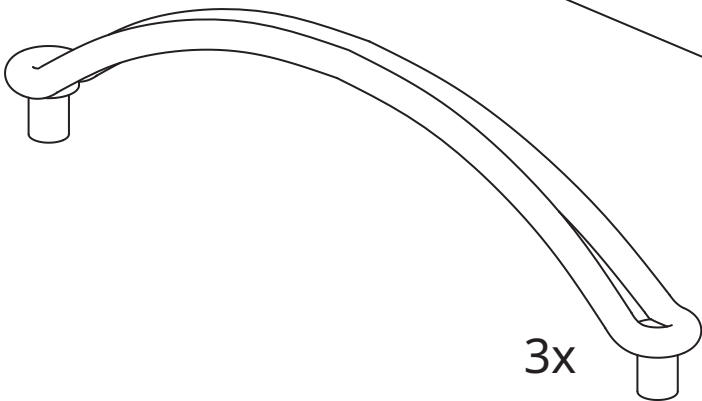

3x

157426

# 1

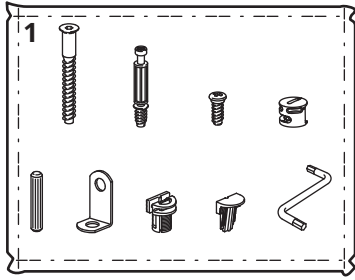
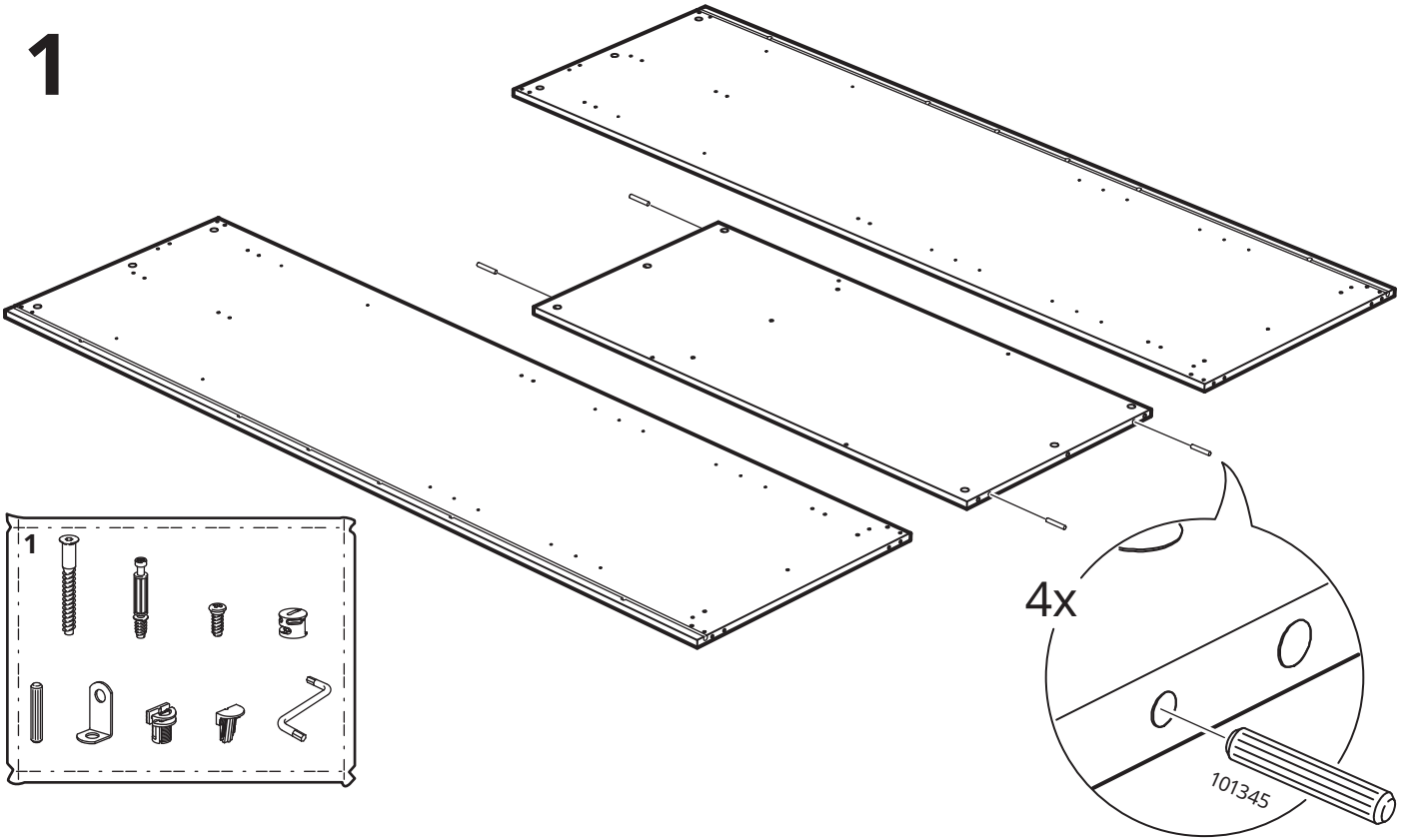

# 2

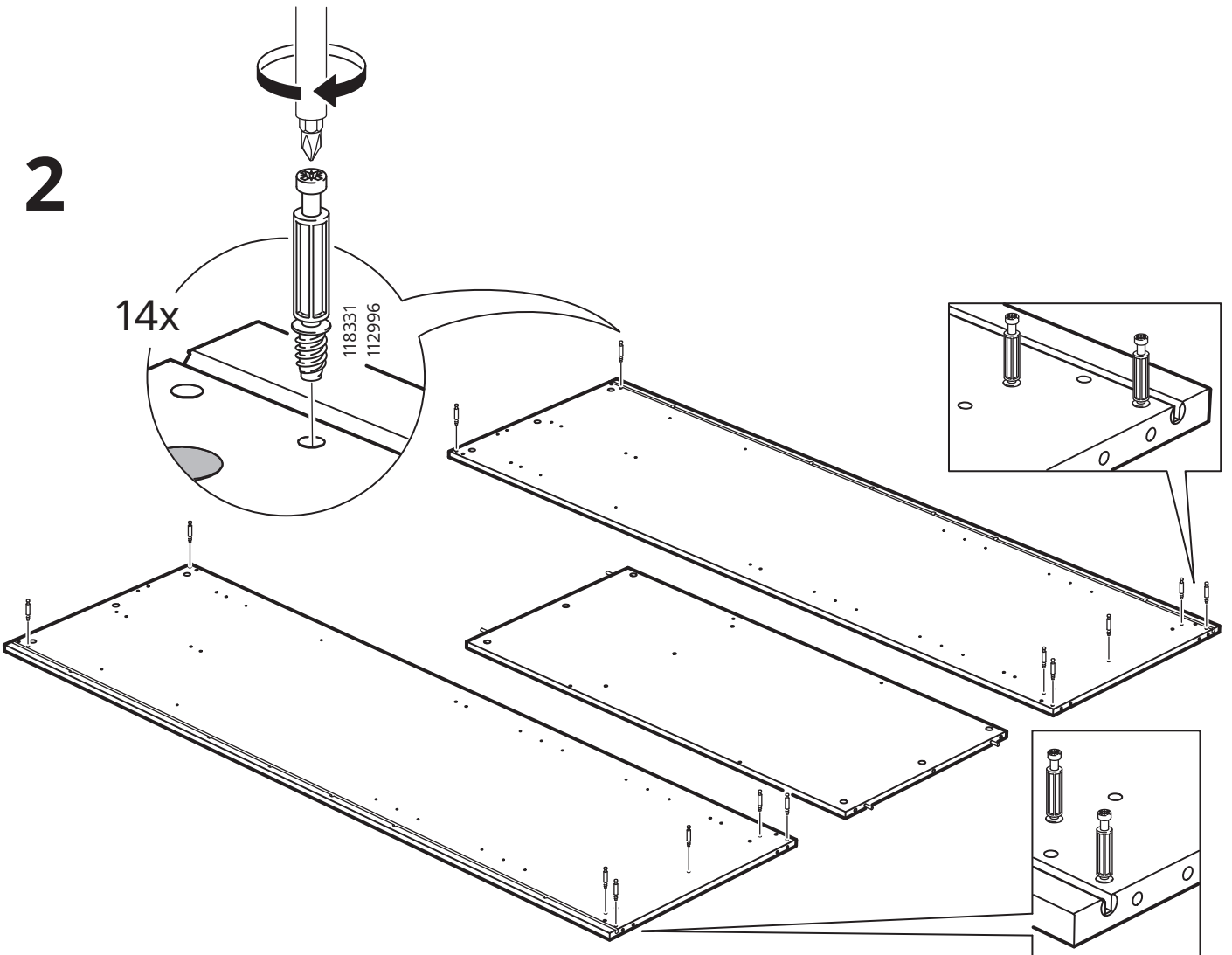

3

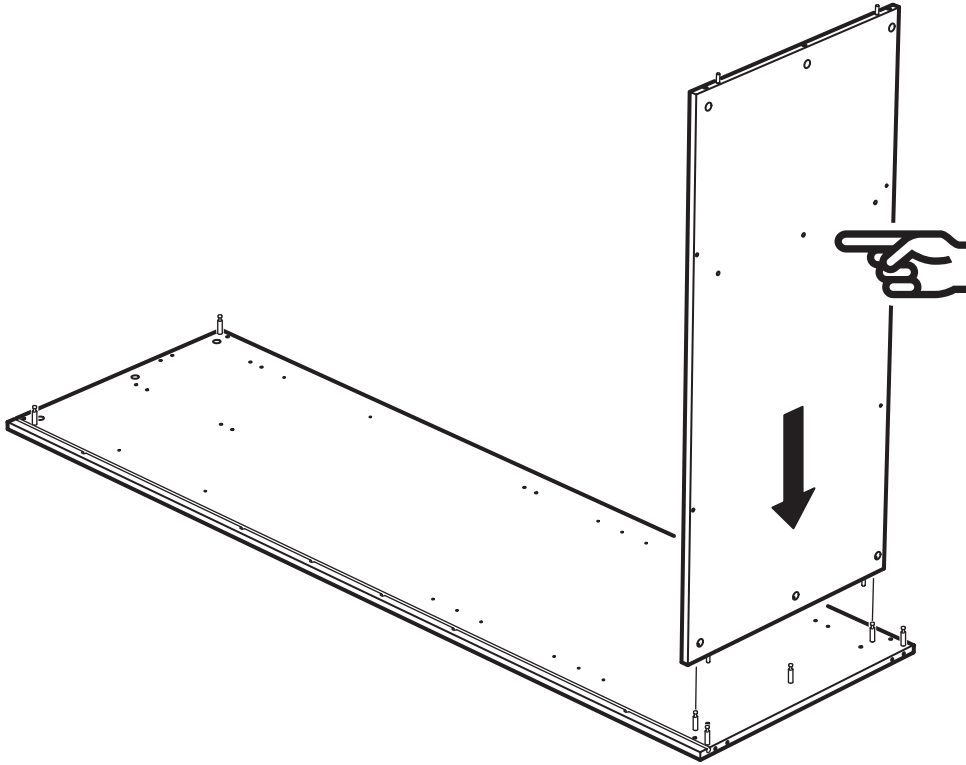

4

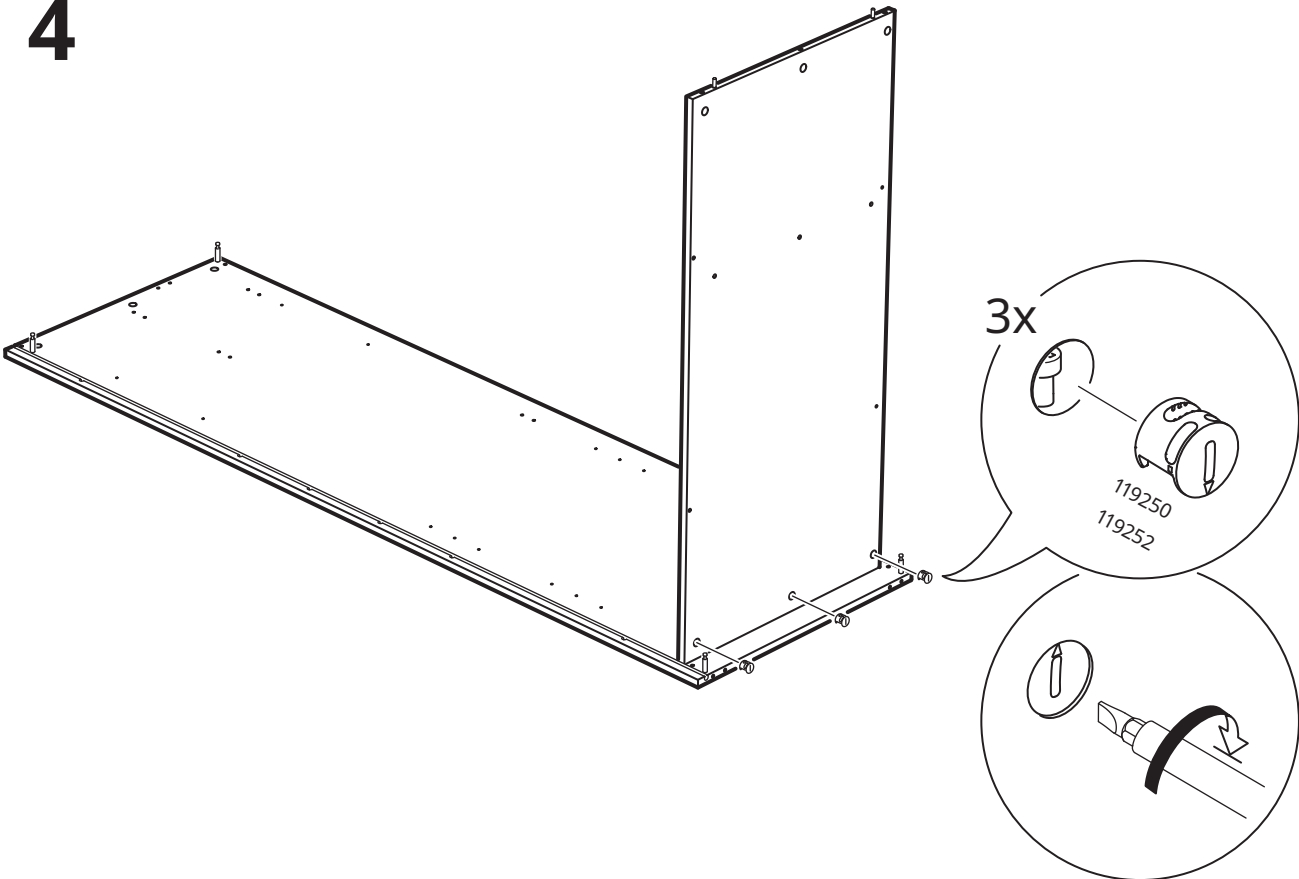

5

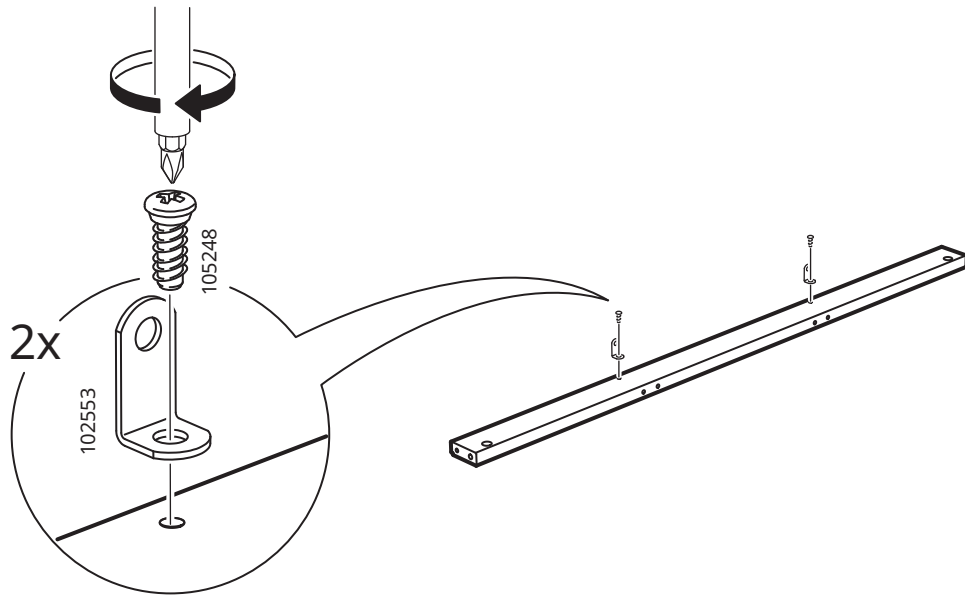

6

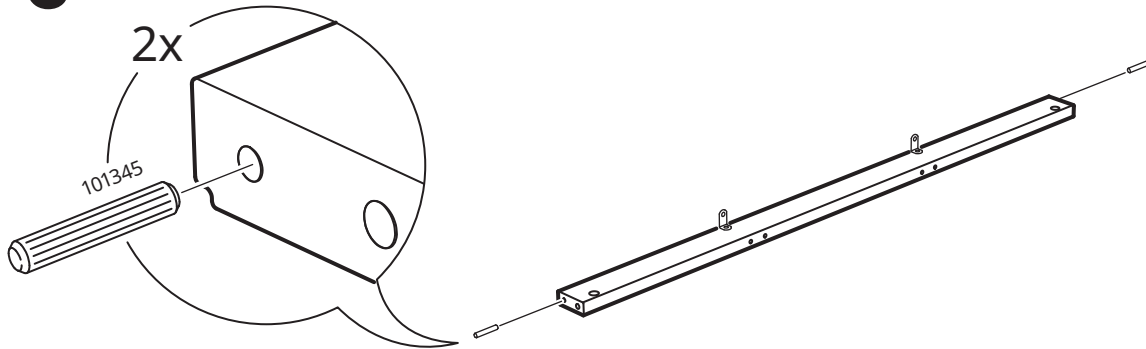

7

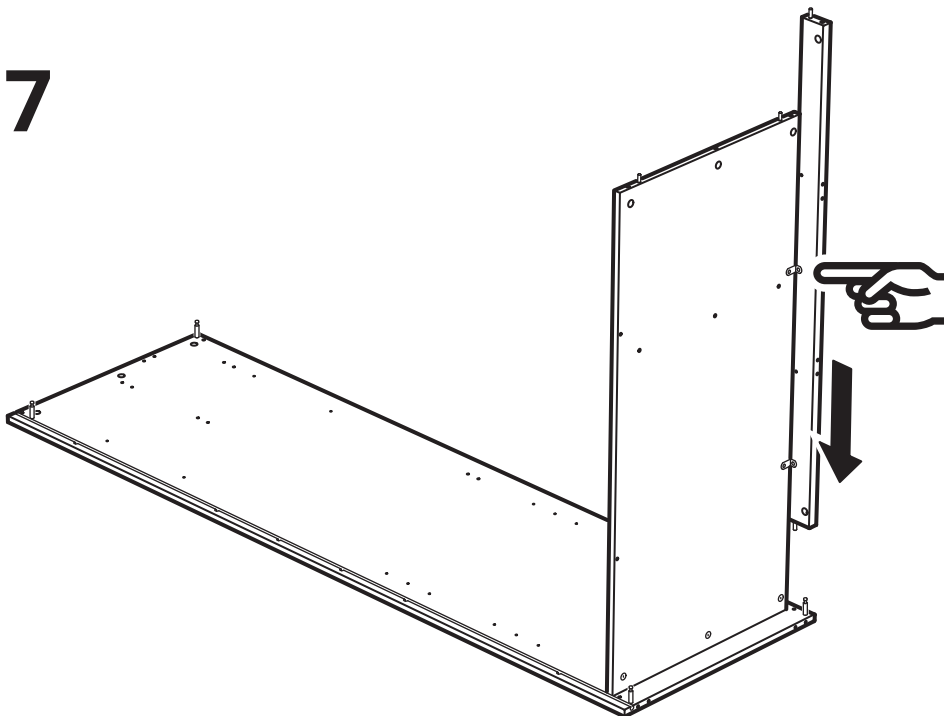

8

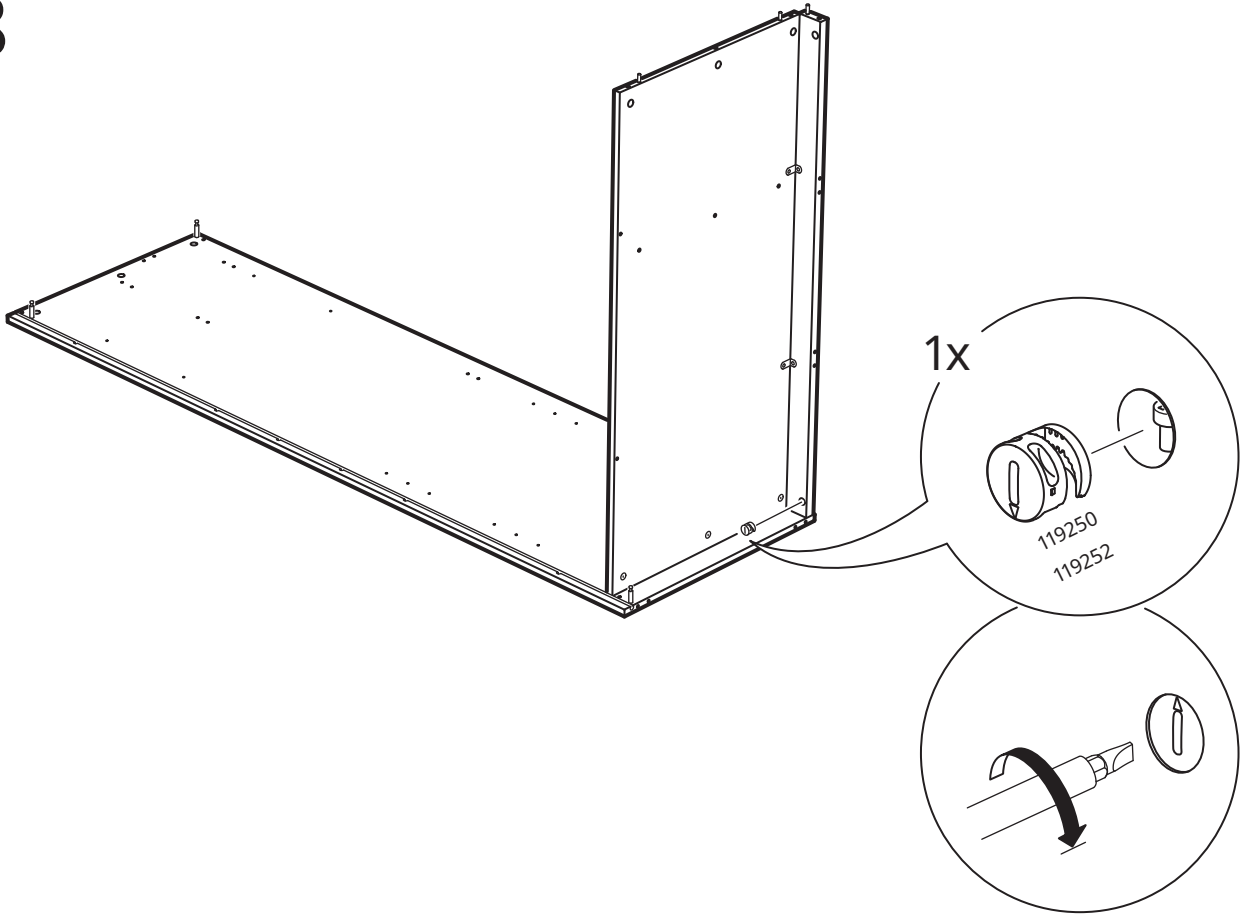

9

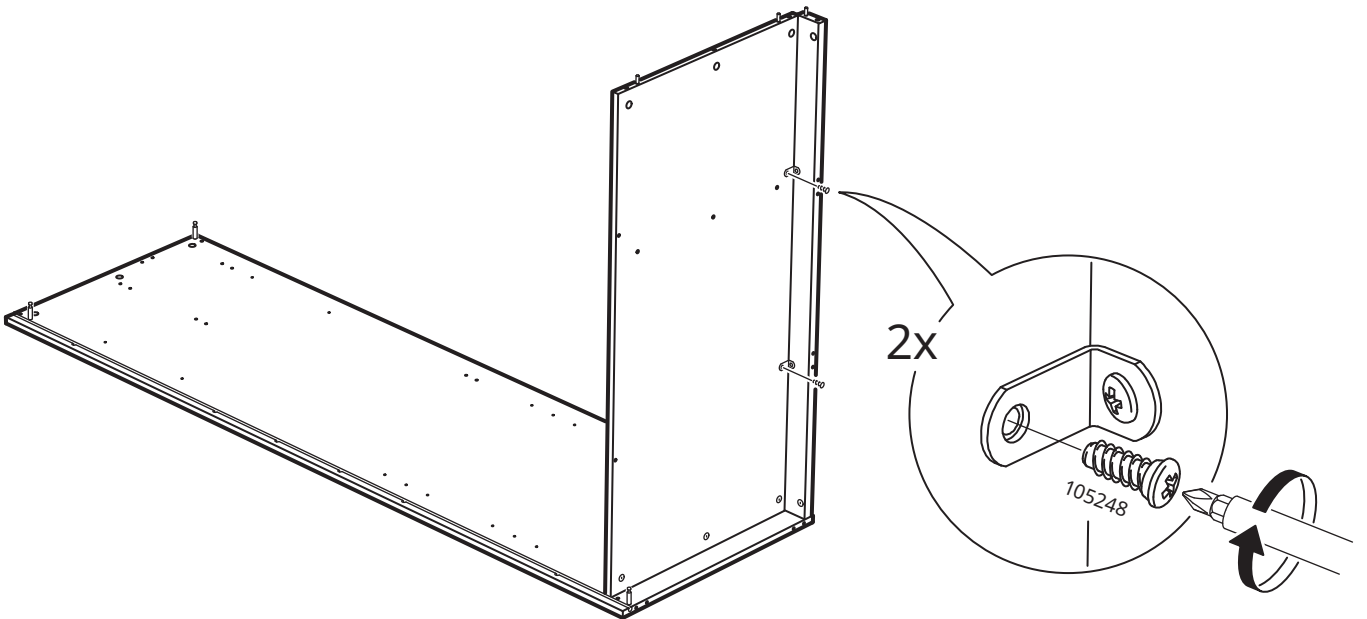

10

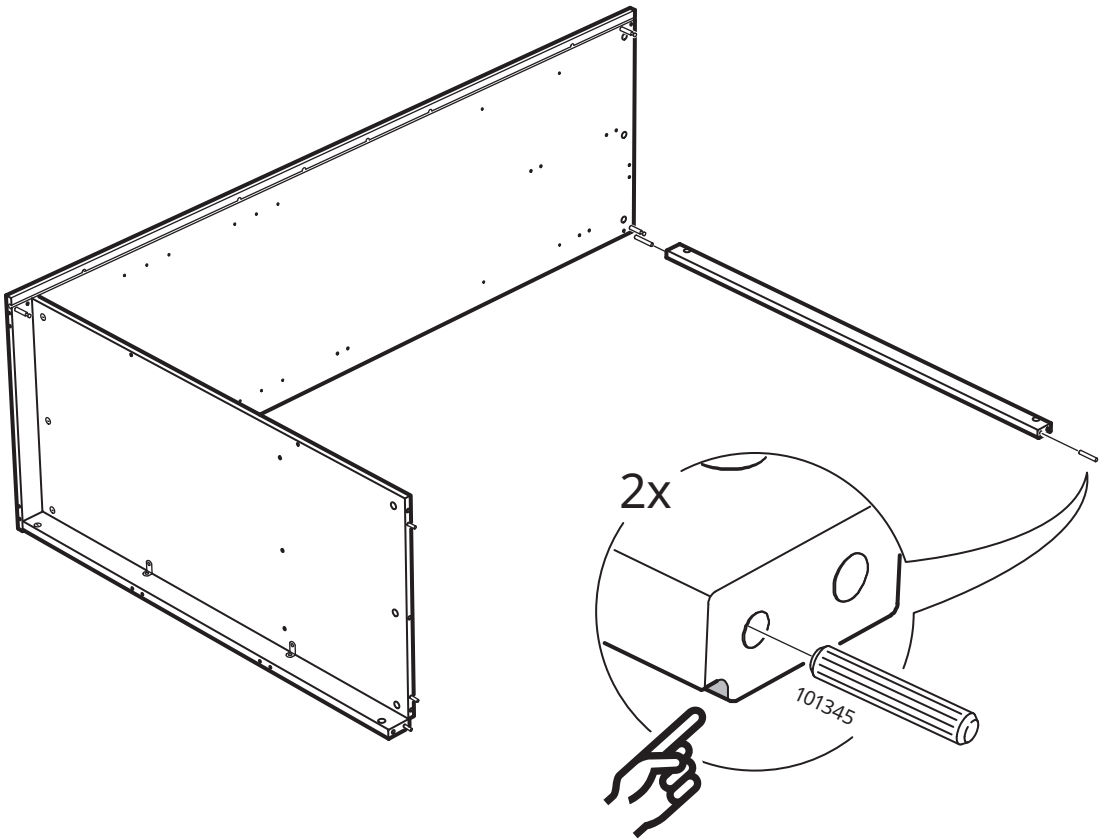
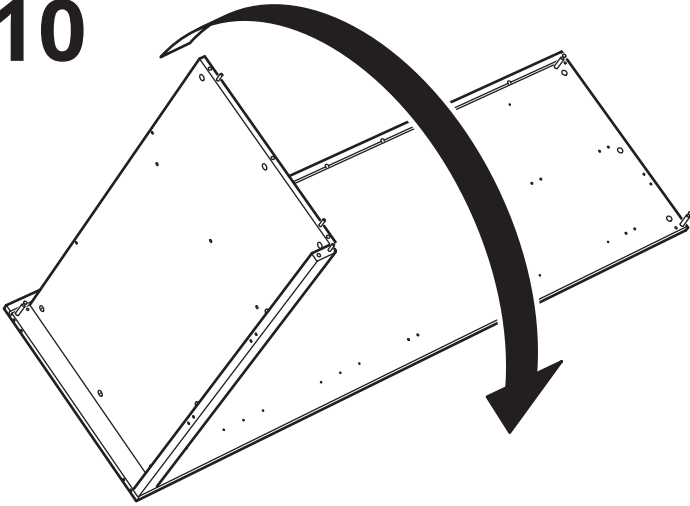

# 11

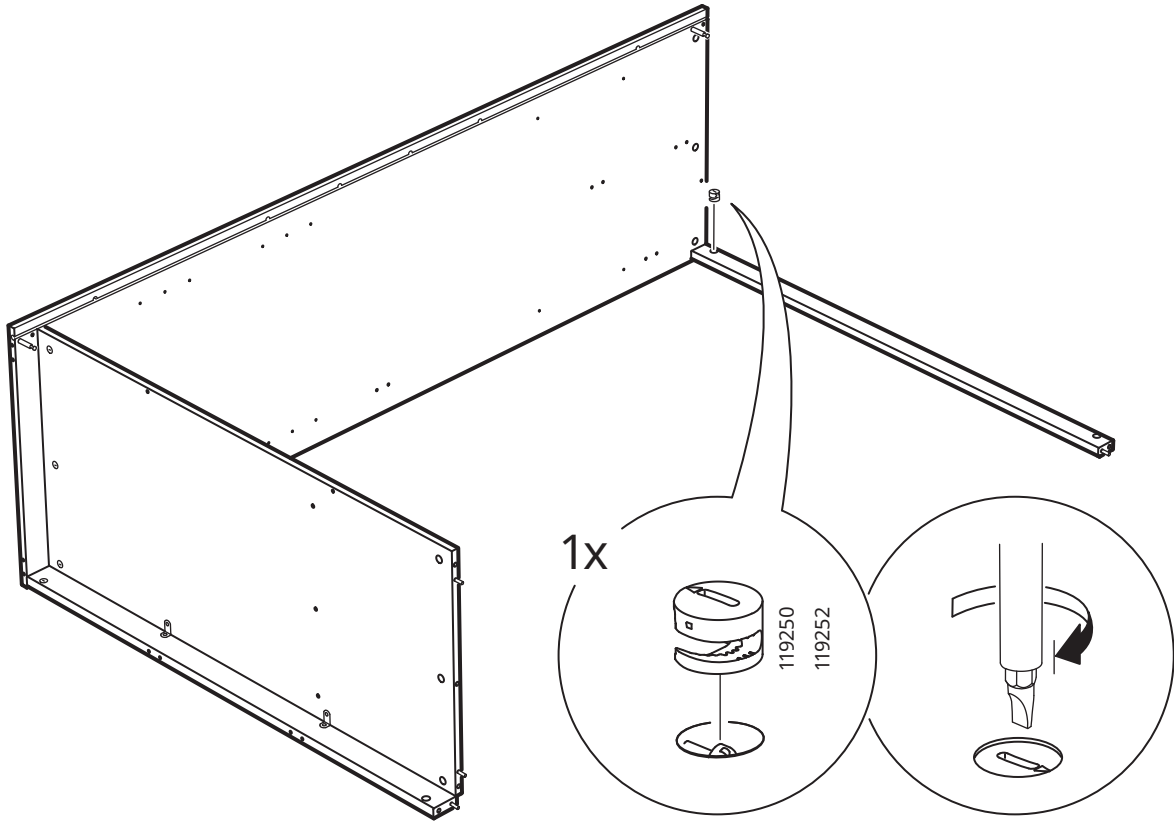

# 12

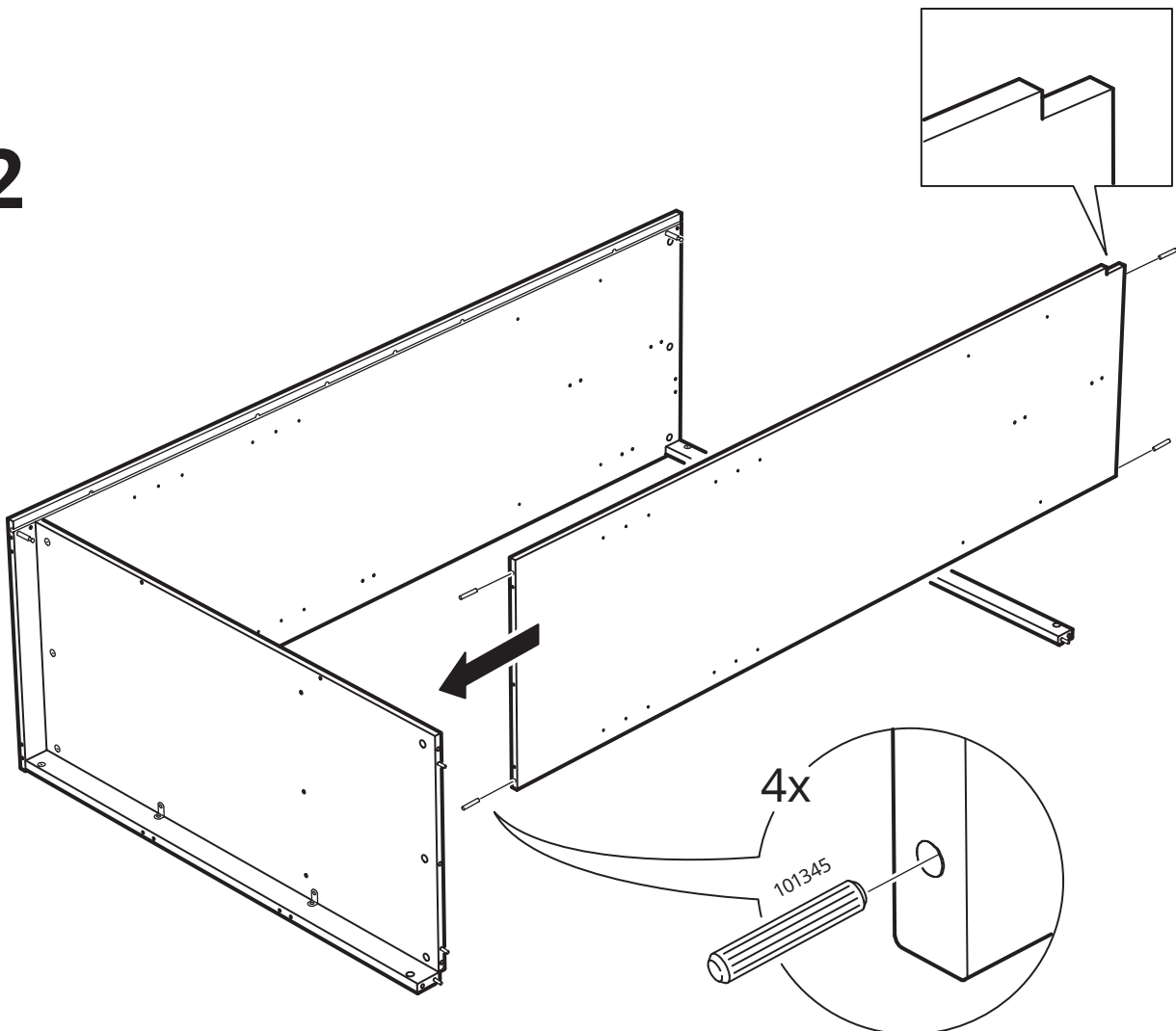

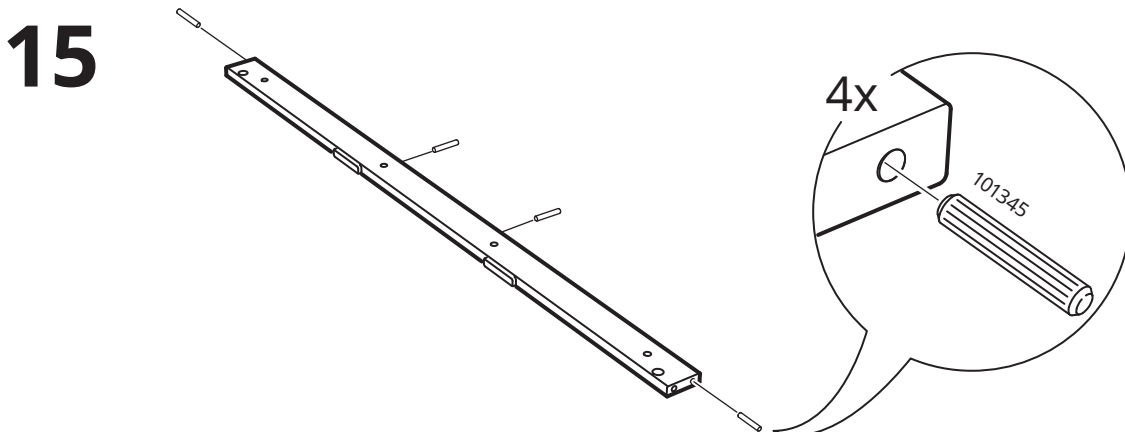
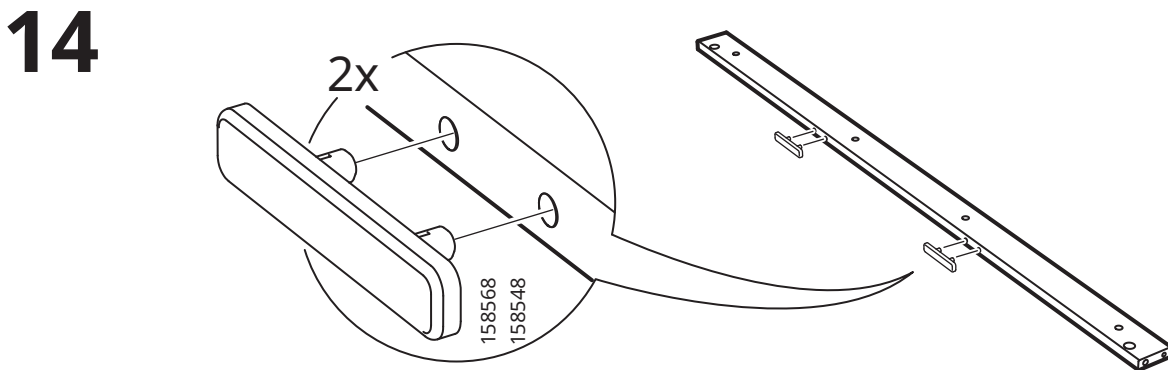
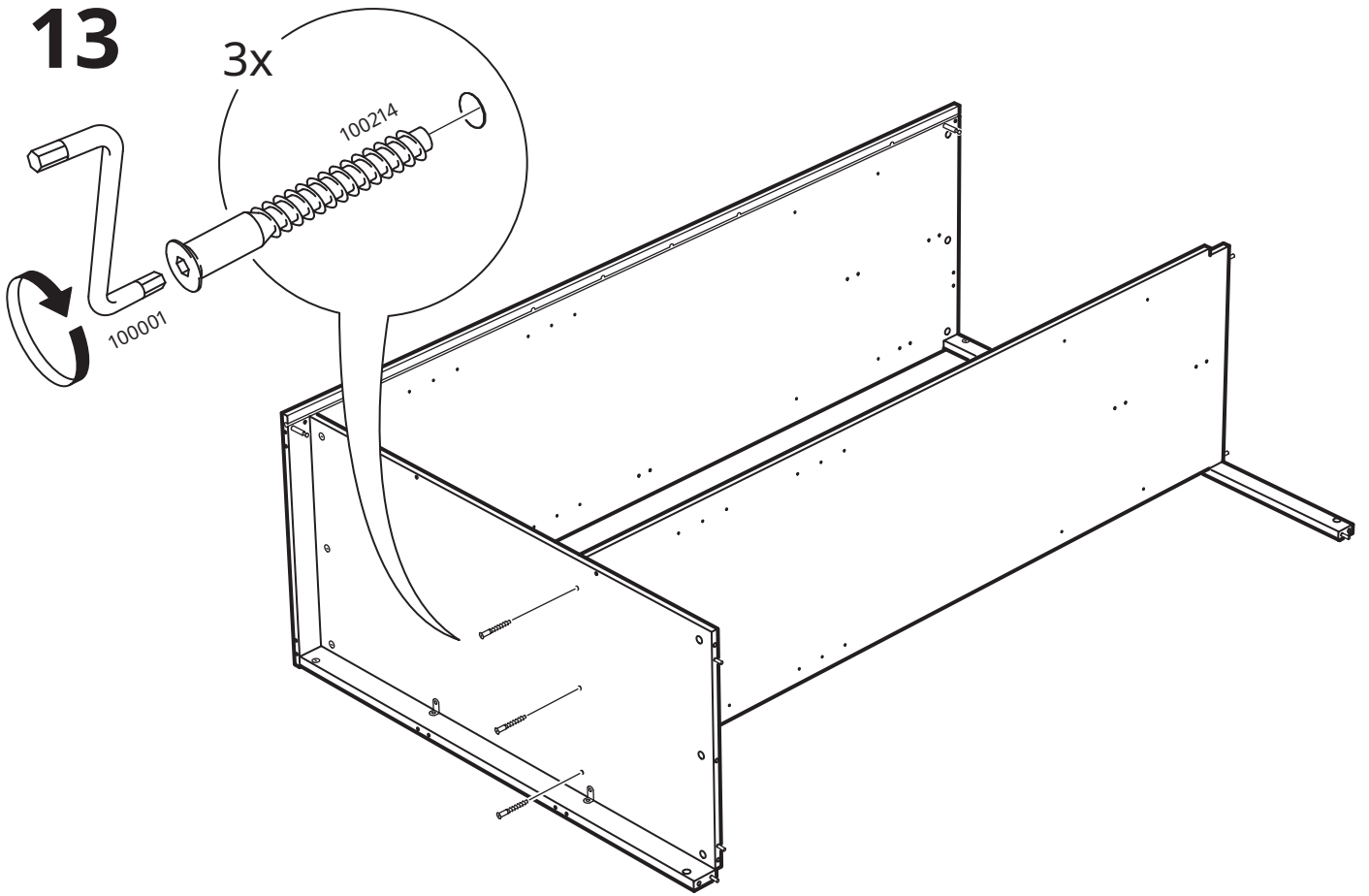

16

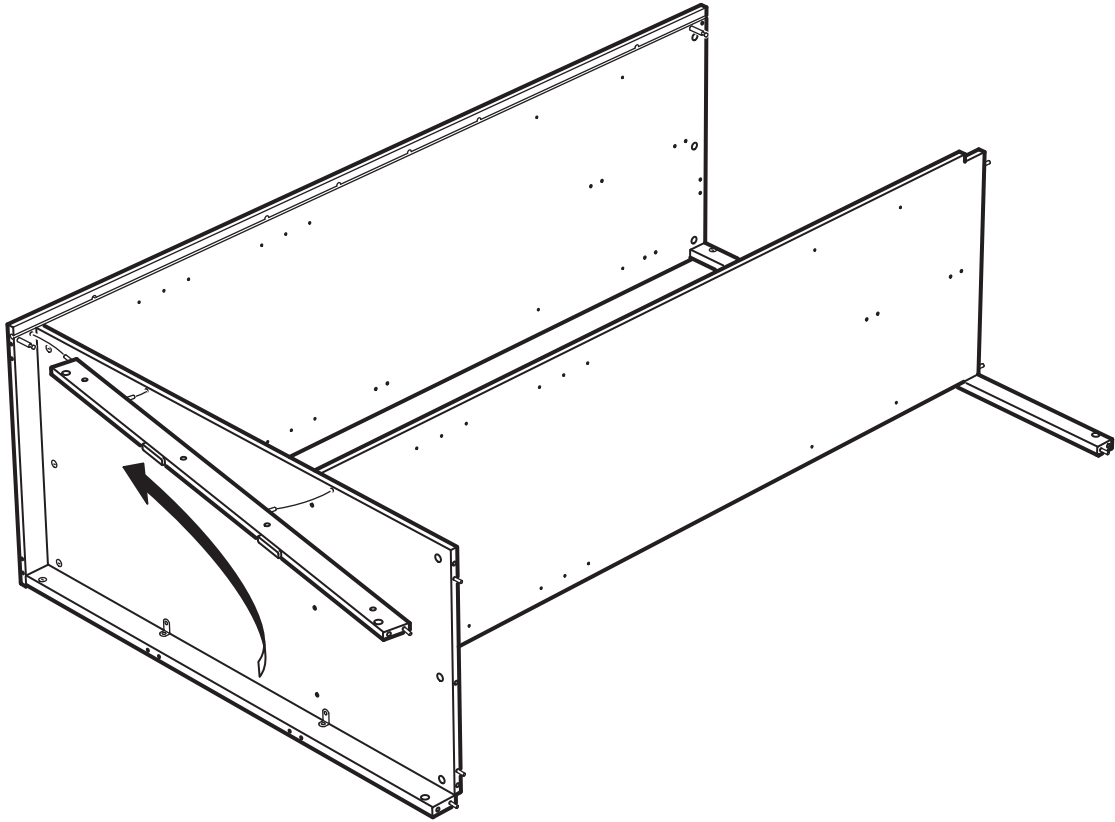

17

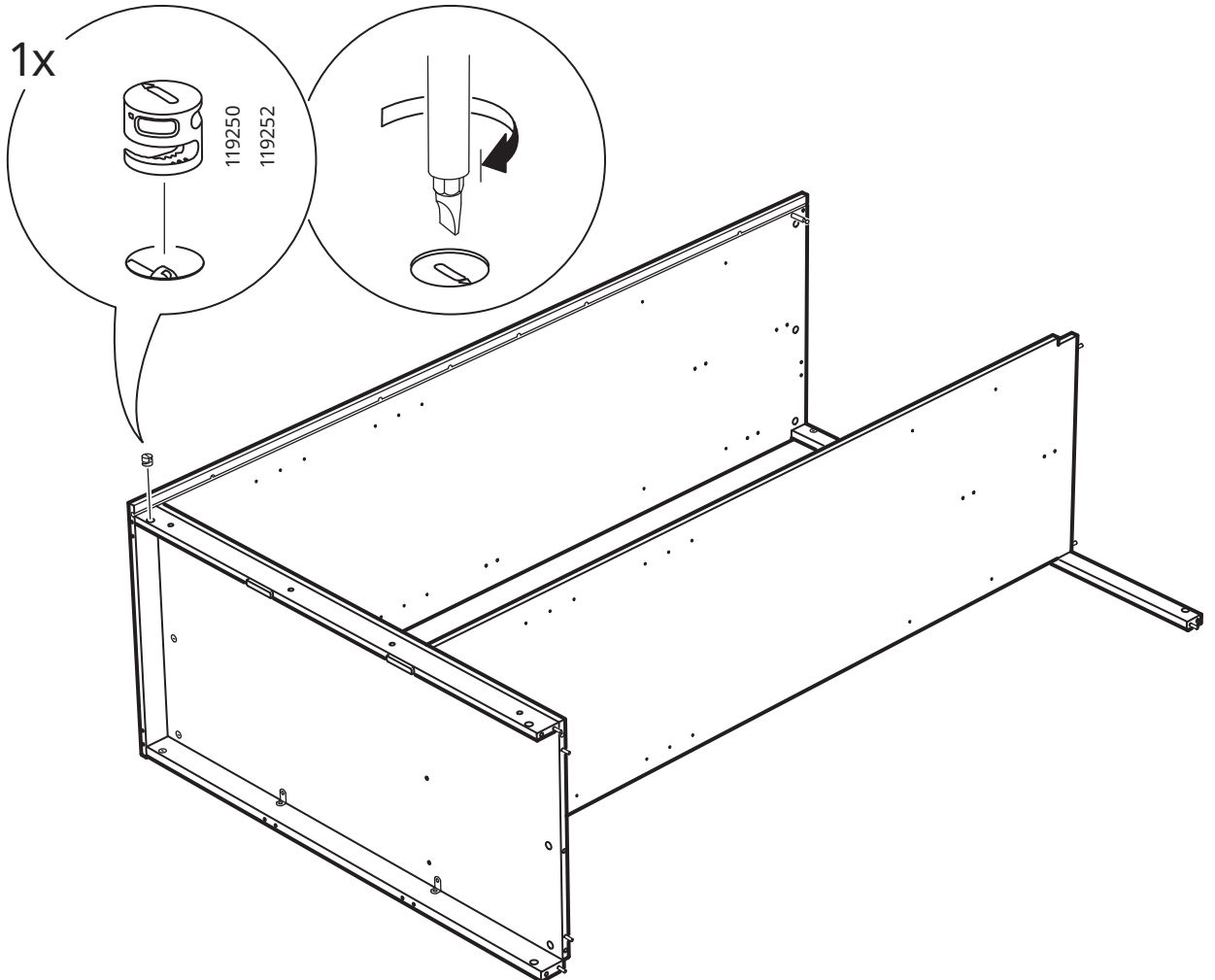

# 18

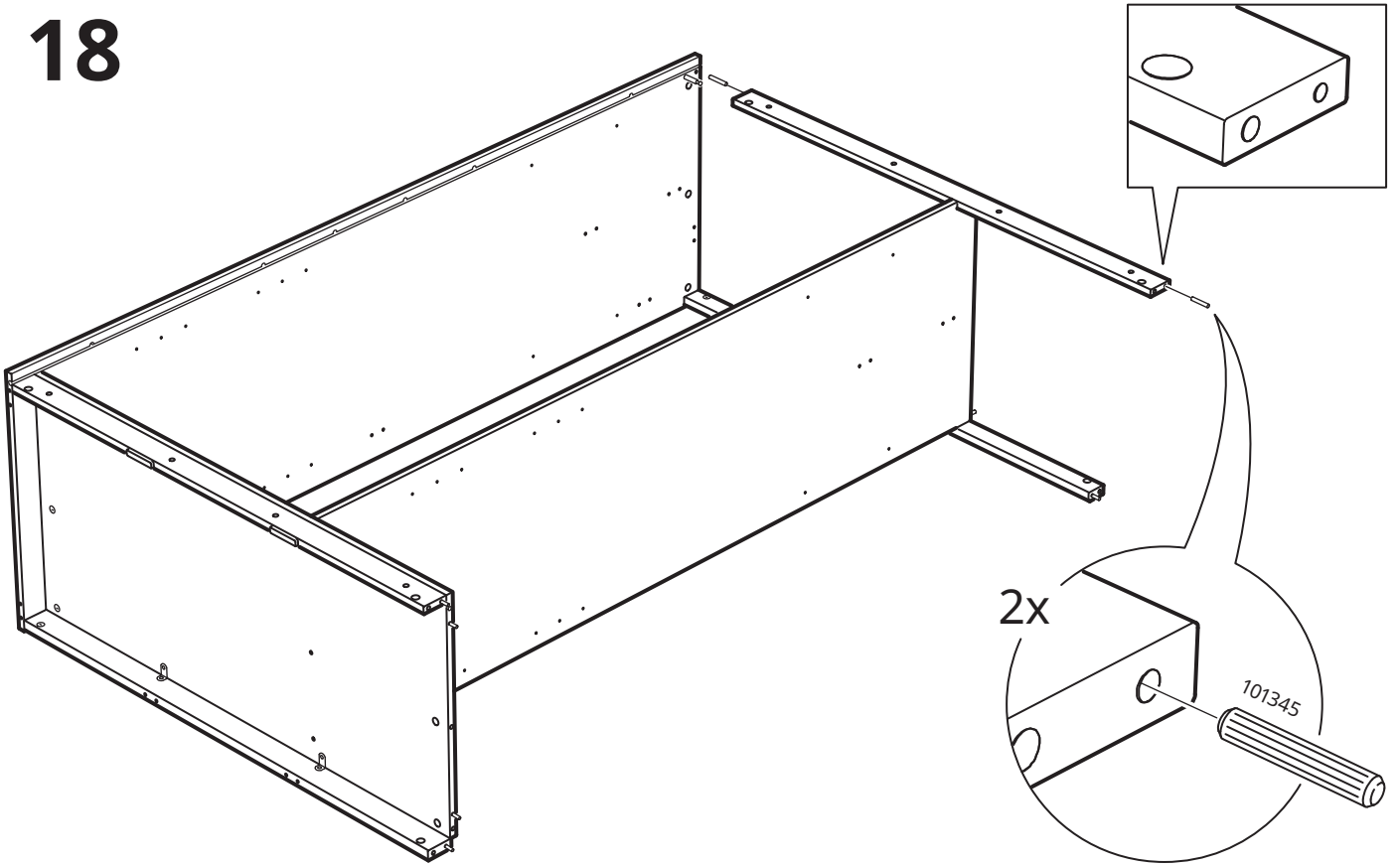

# 19

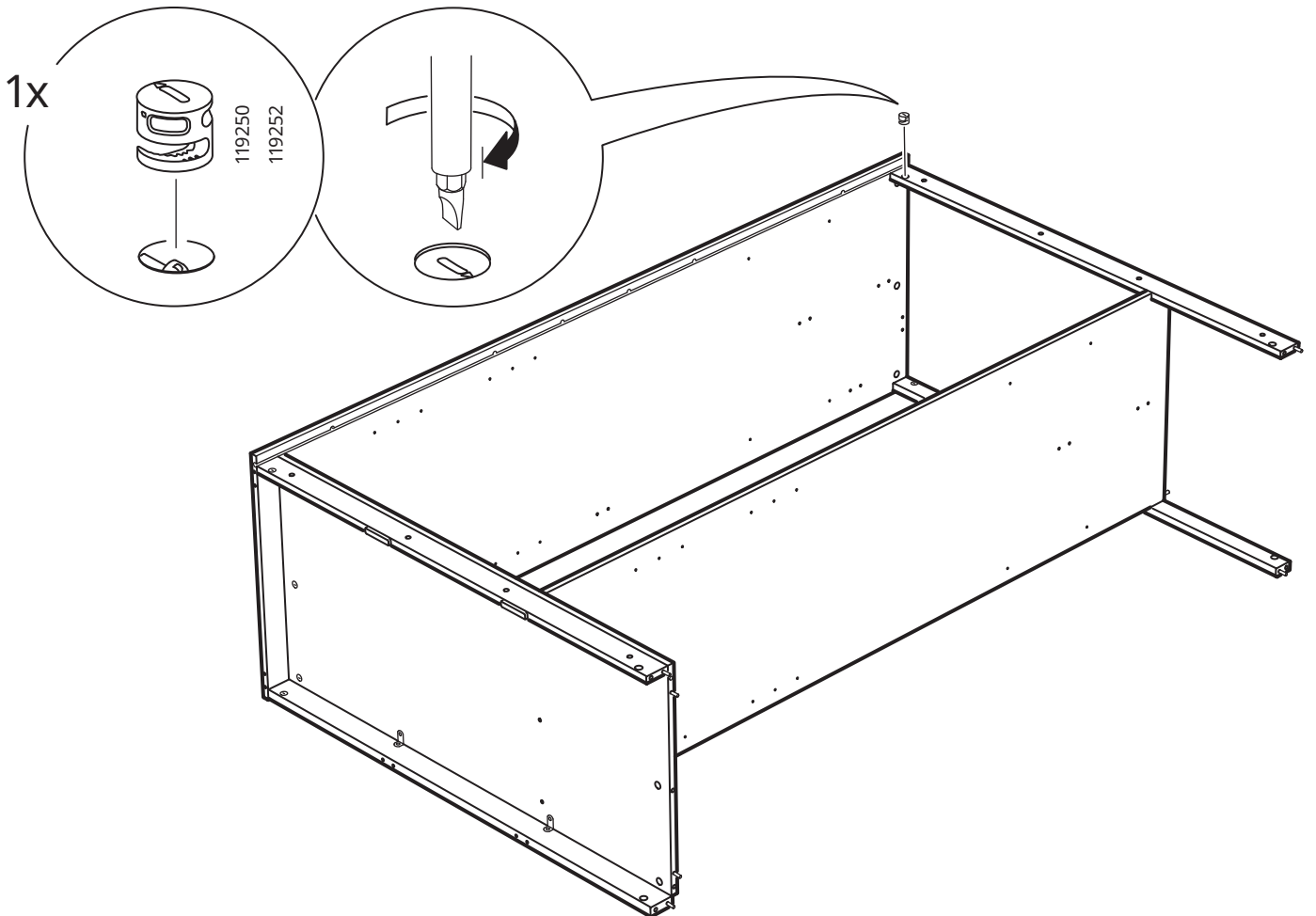

20

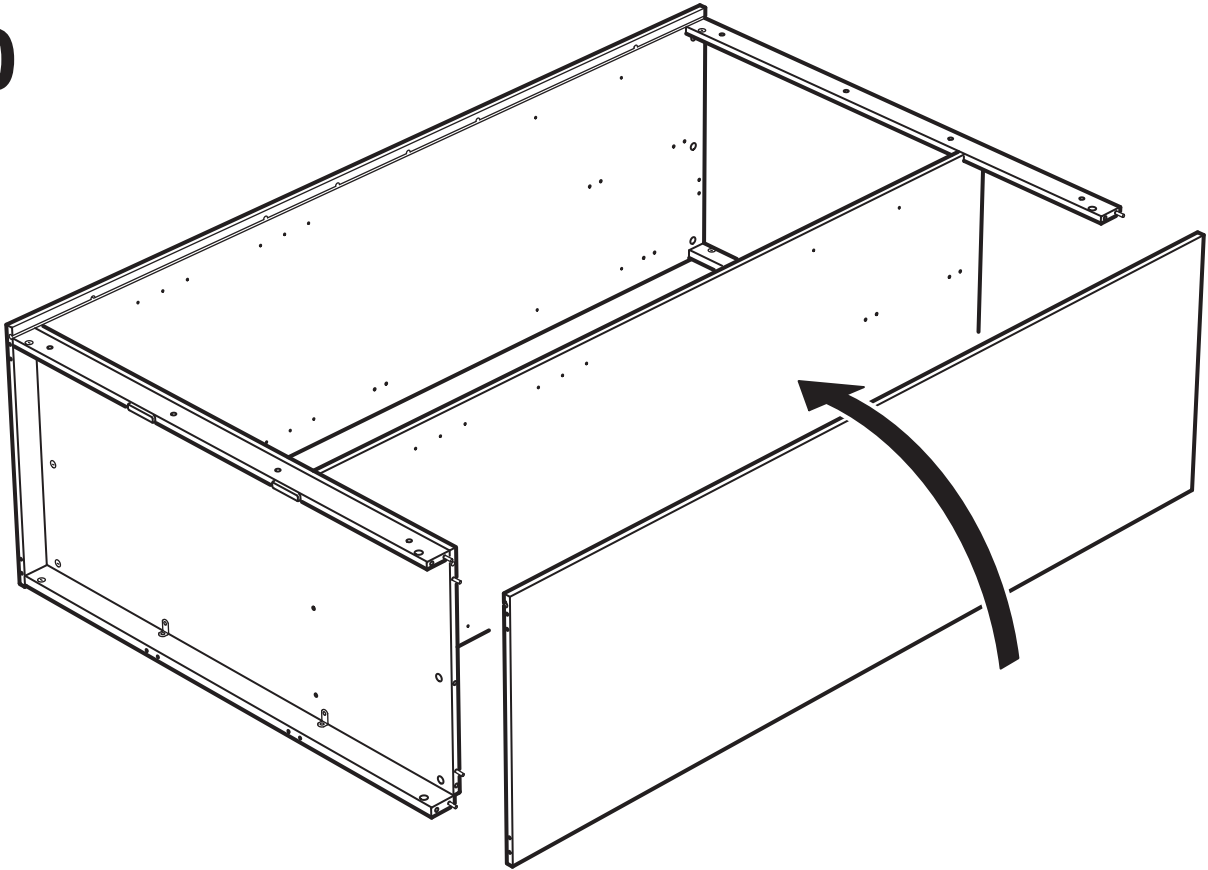

21

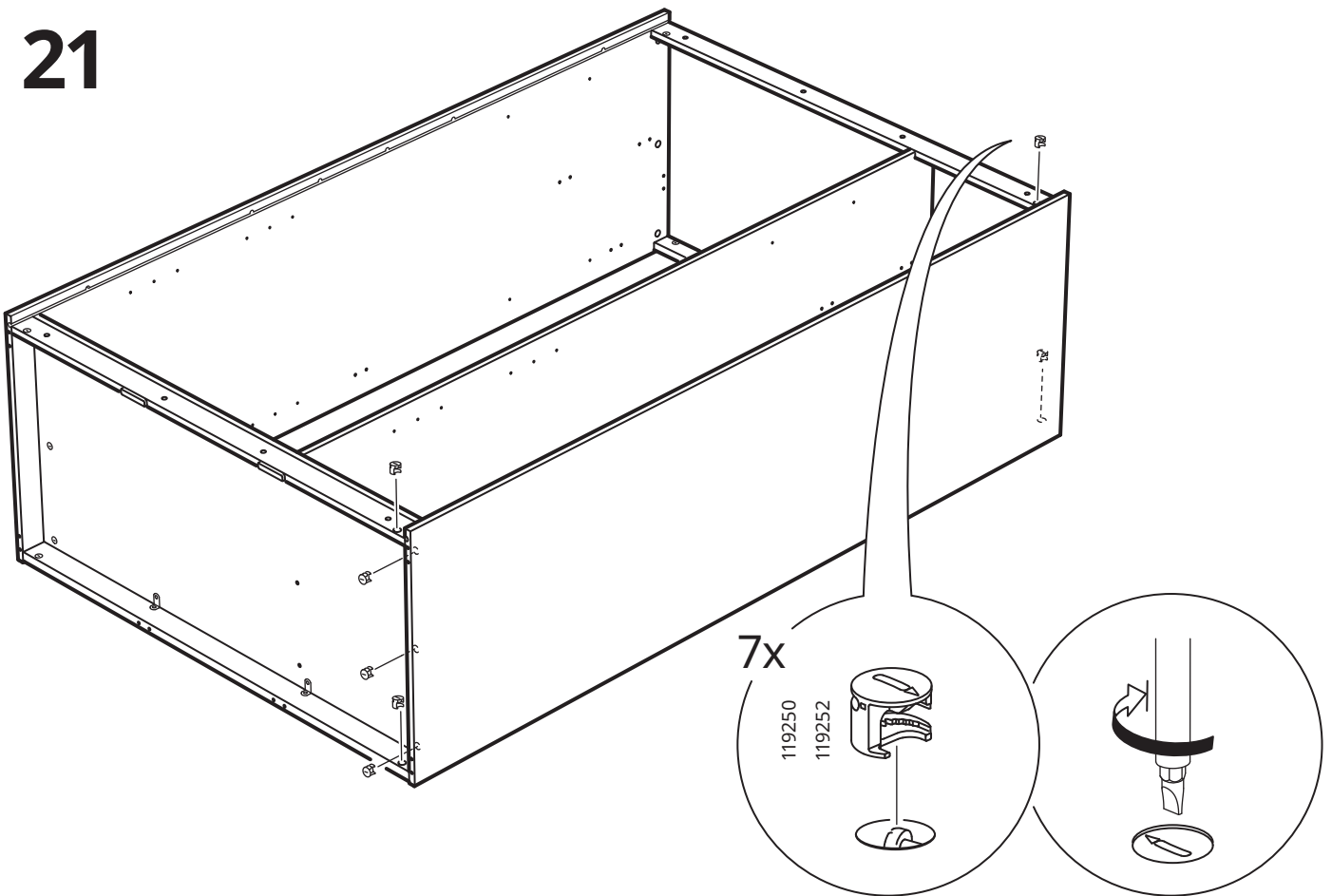

# 22

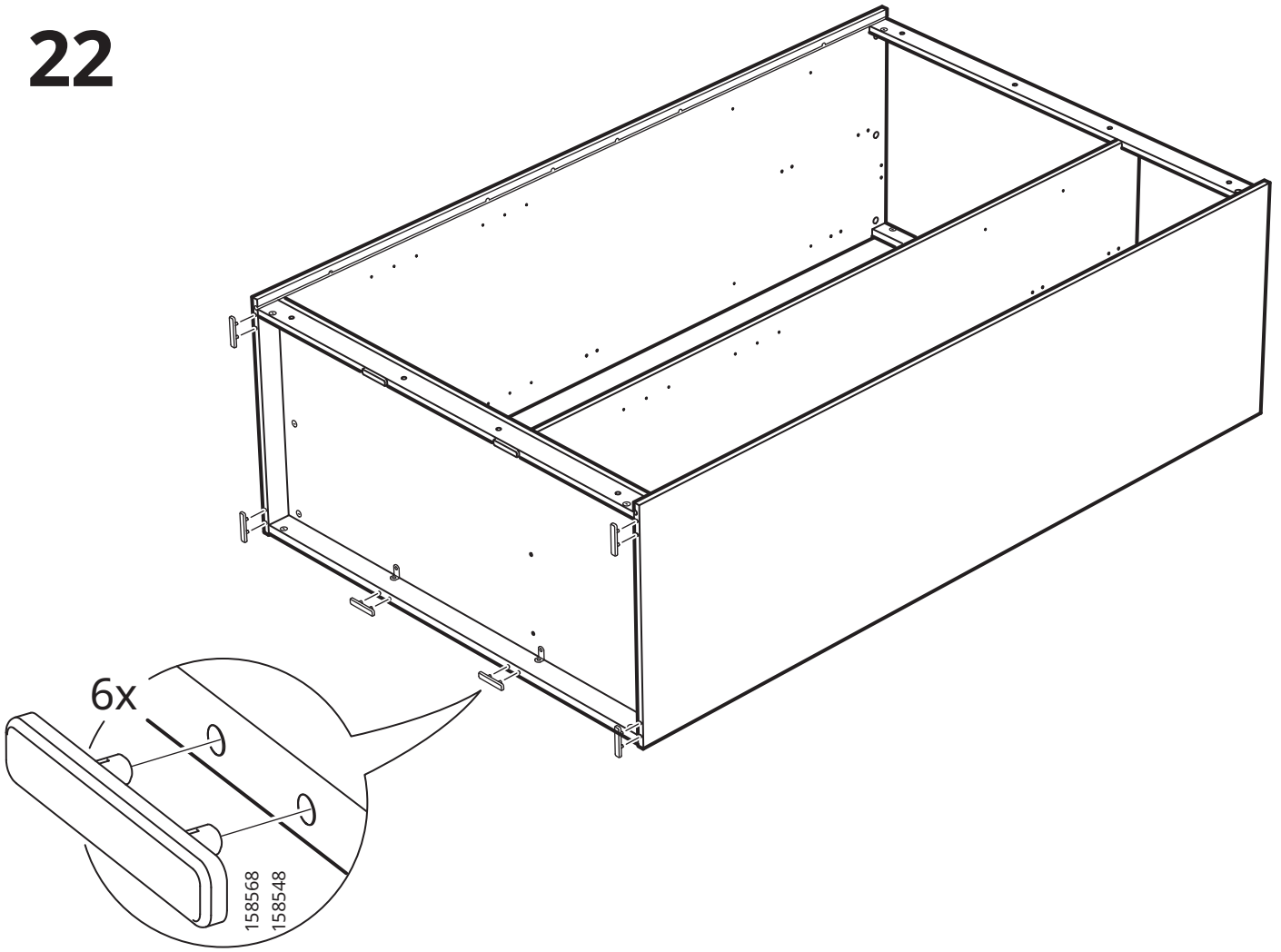

# 23

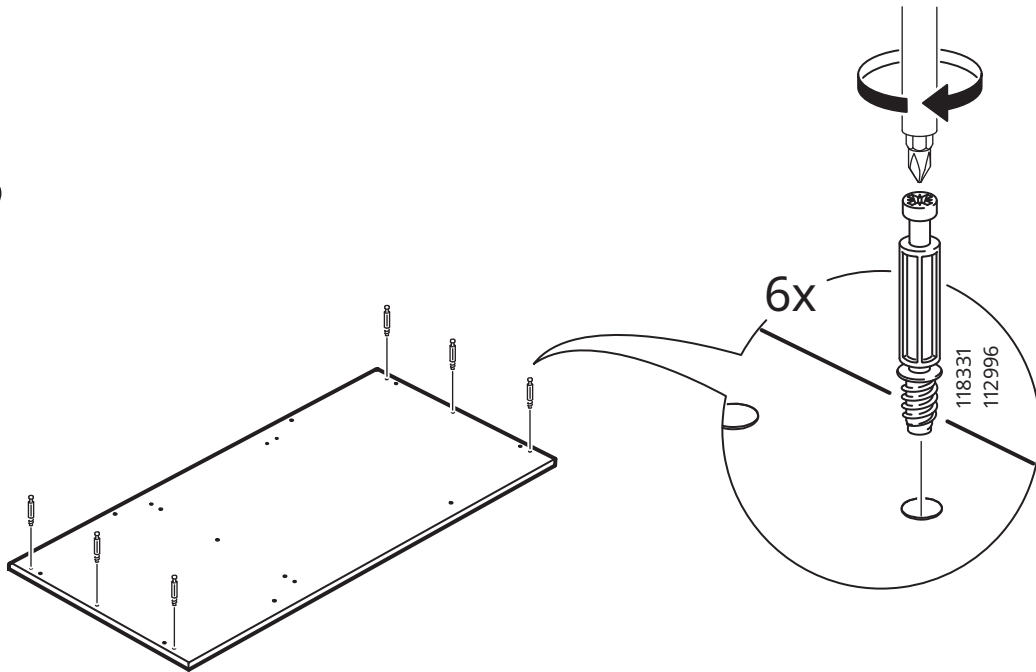

24

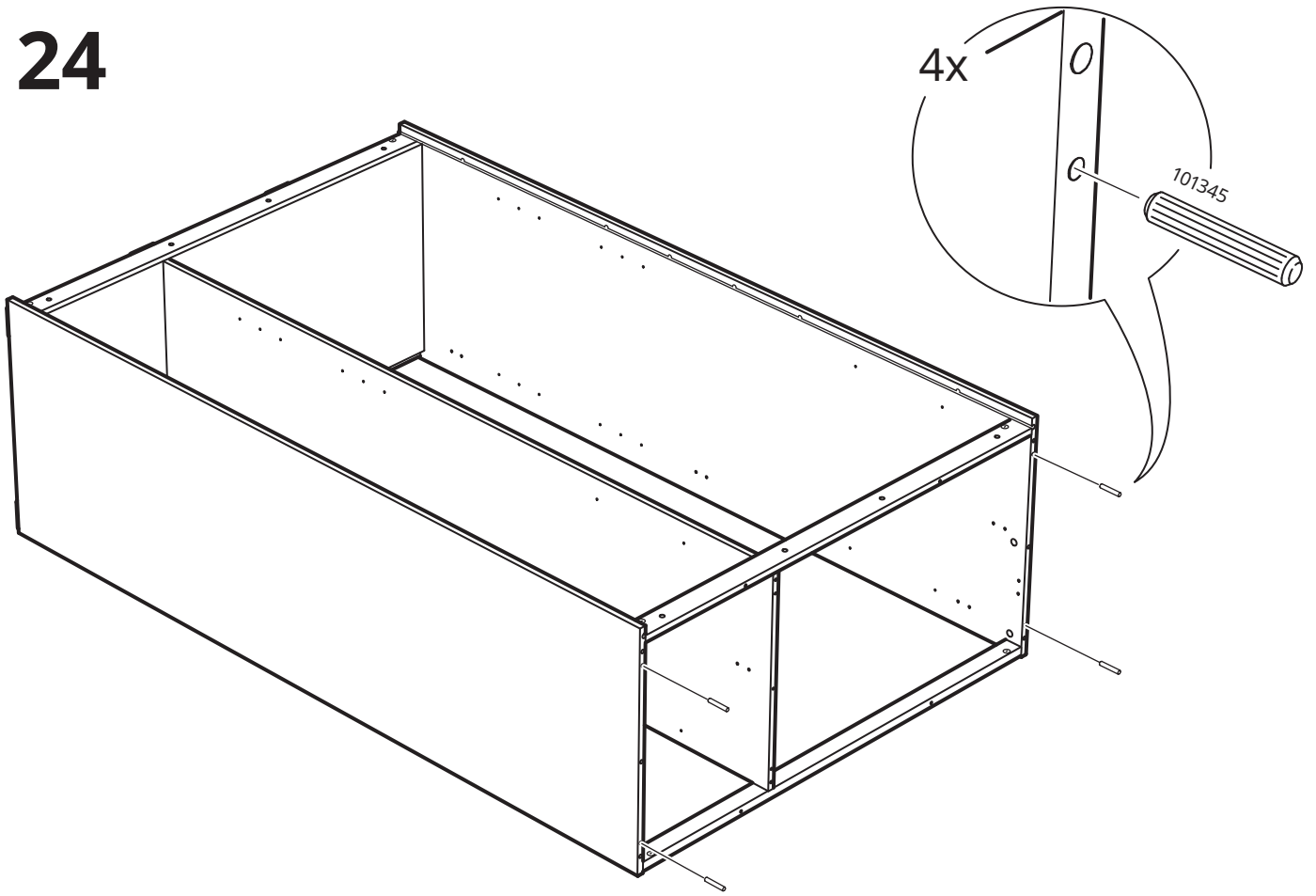

25

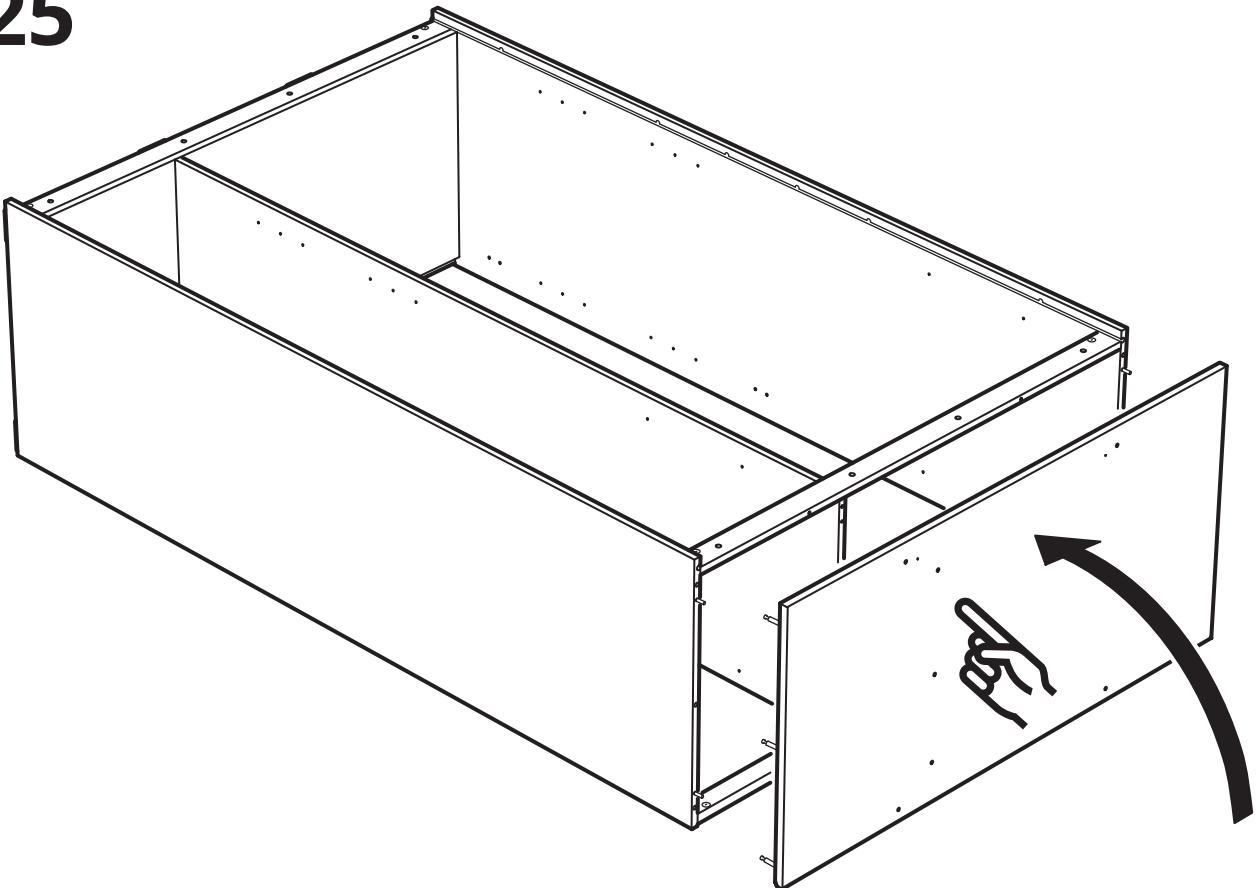

26

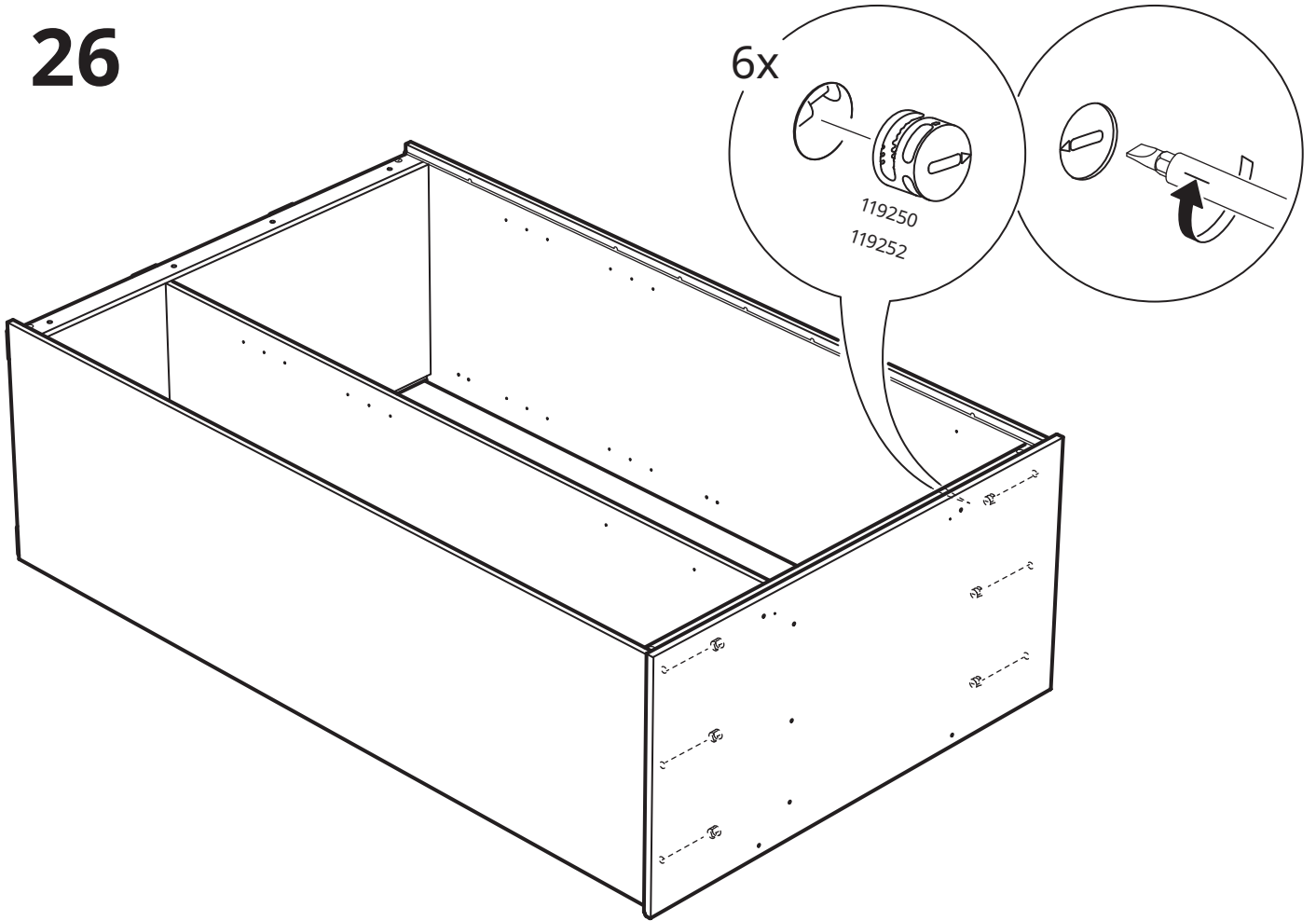

27

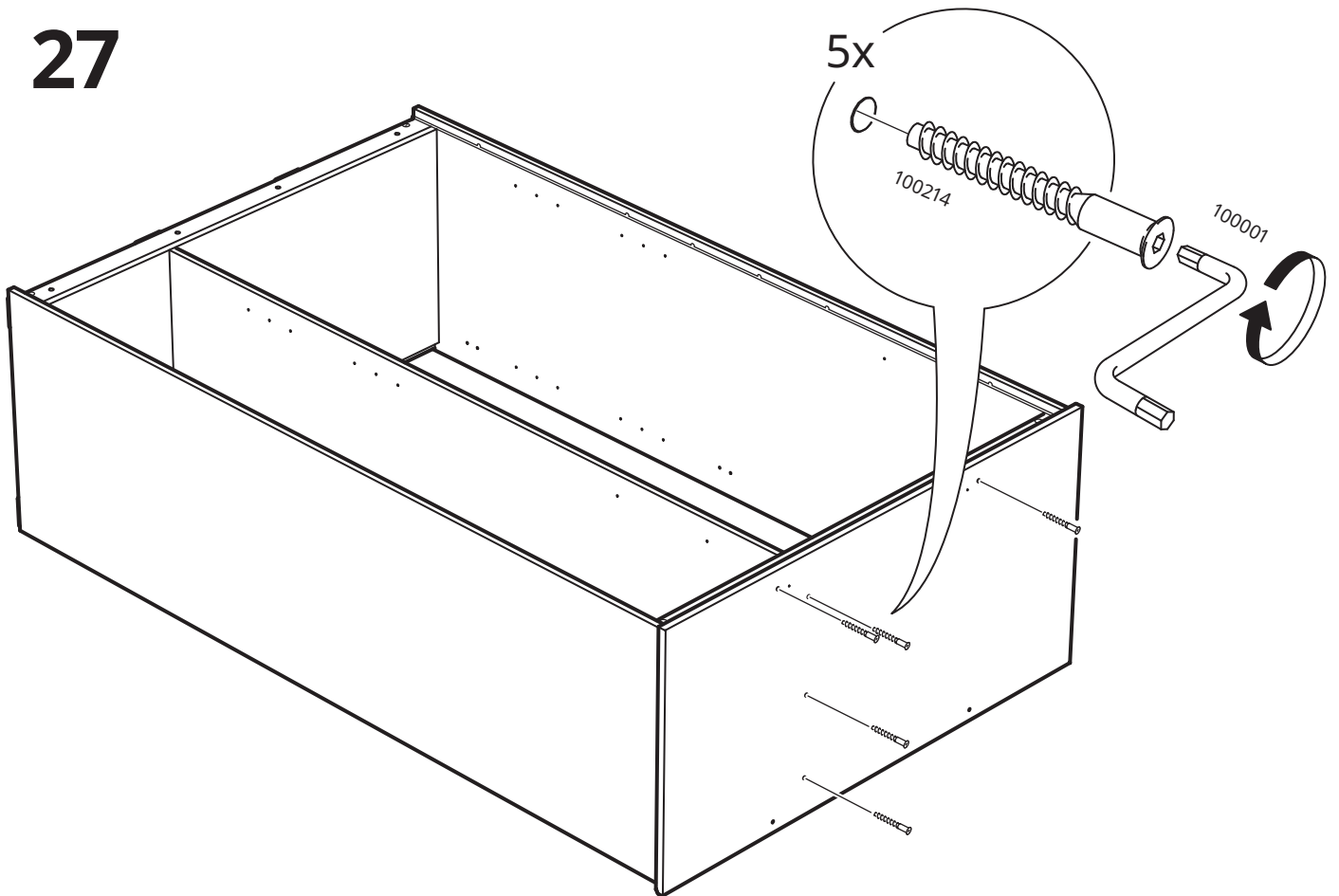

28

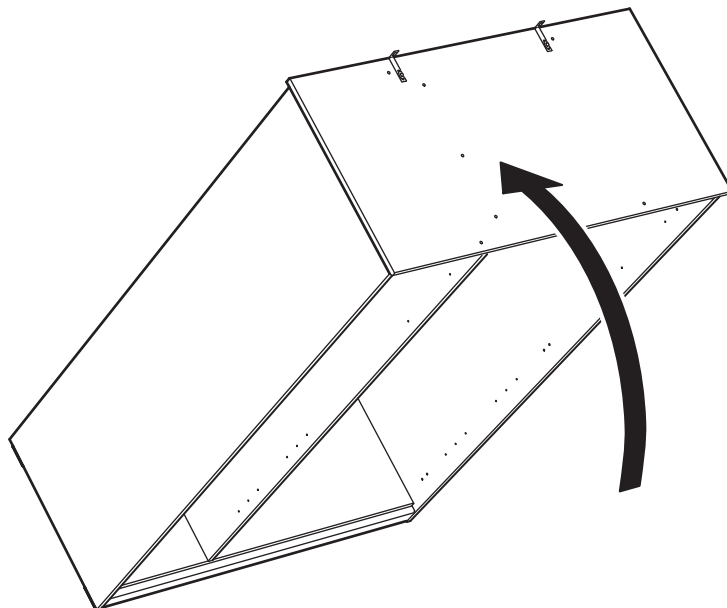
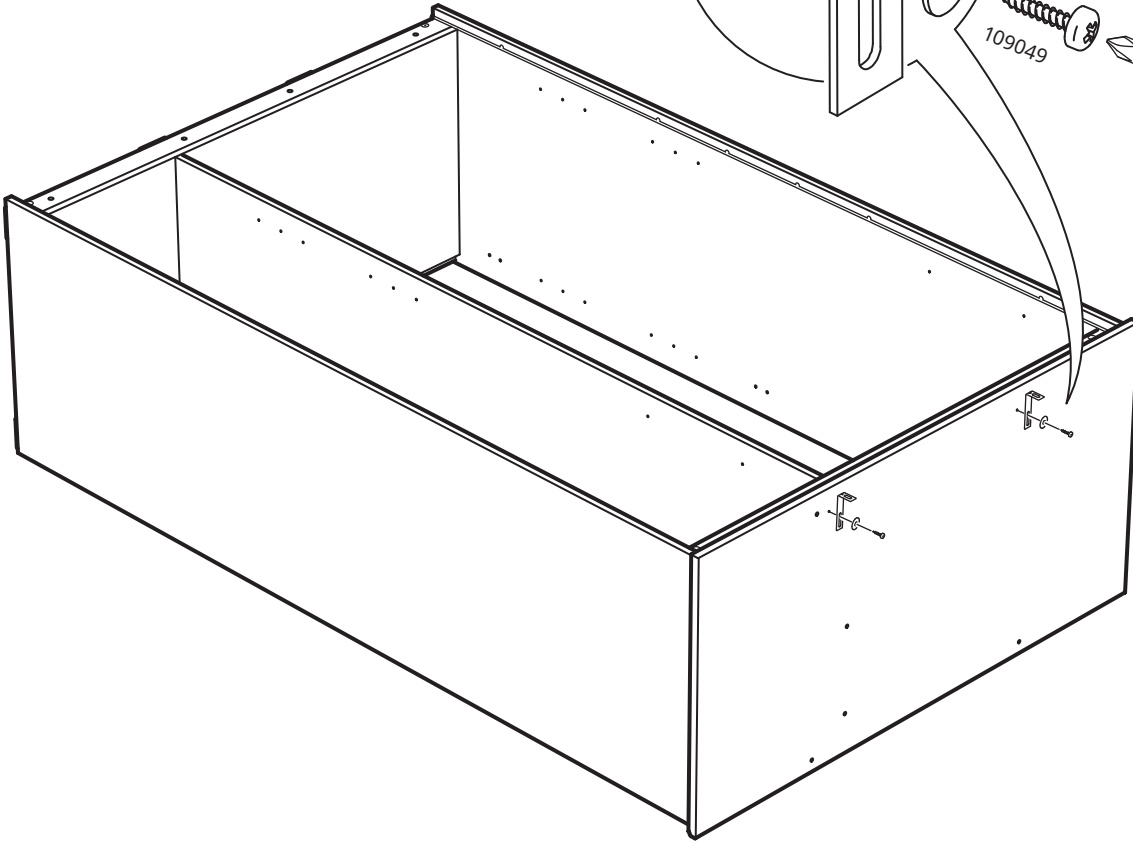
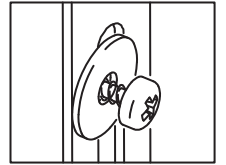
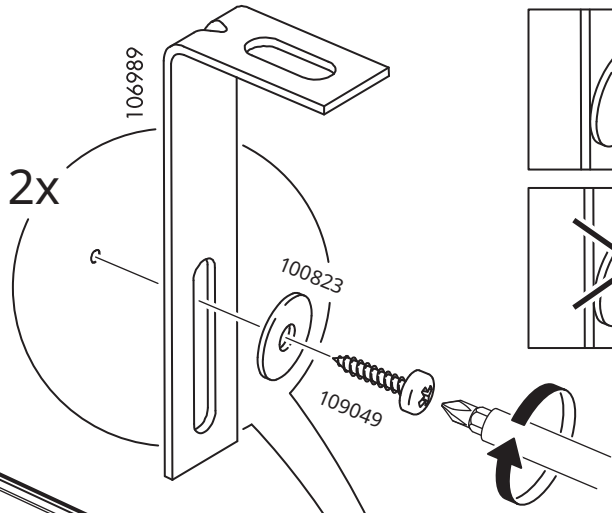
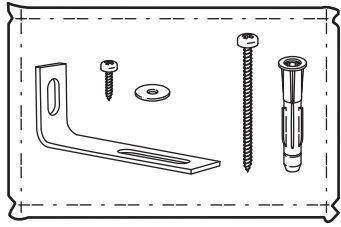

29

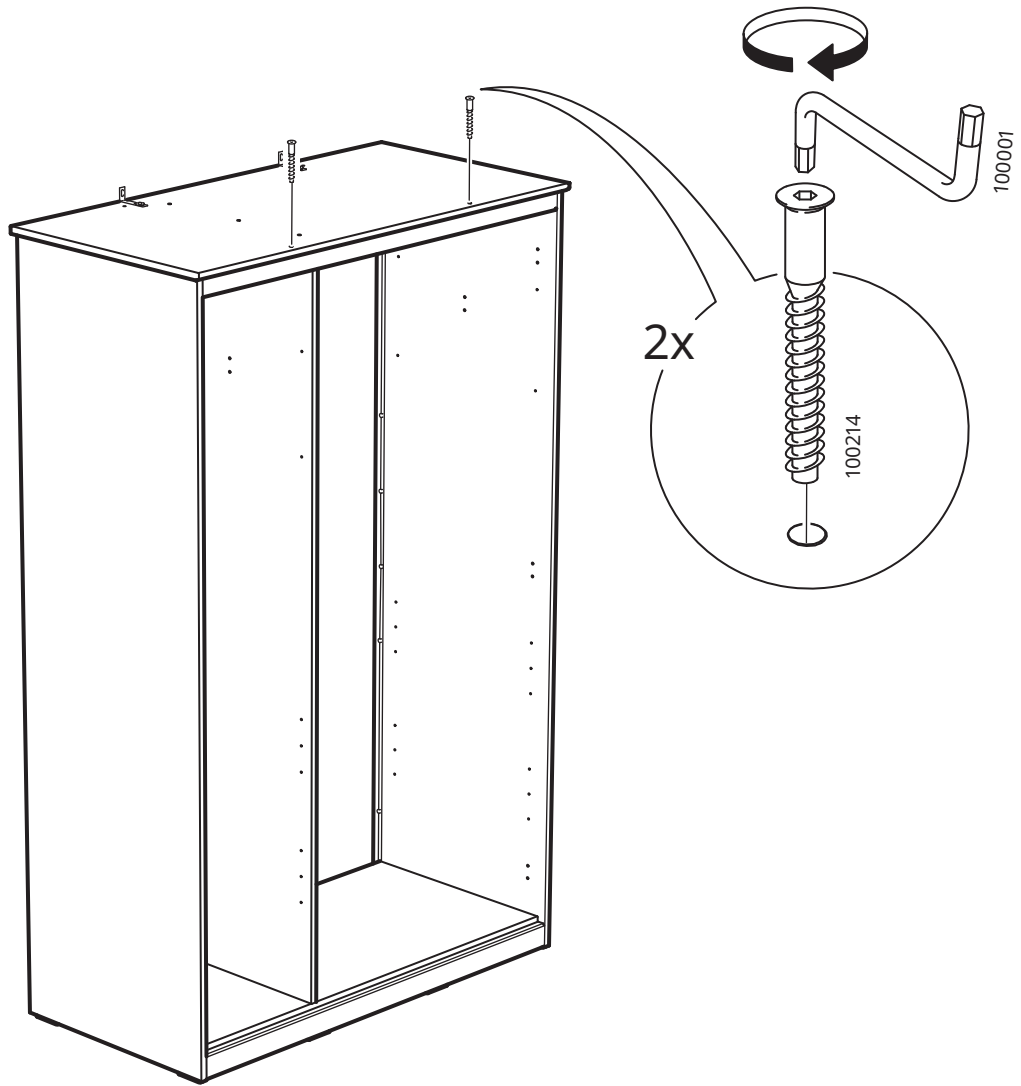

30

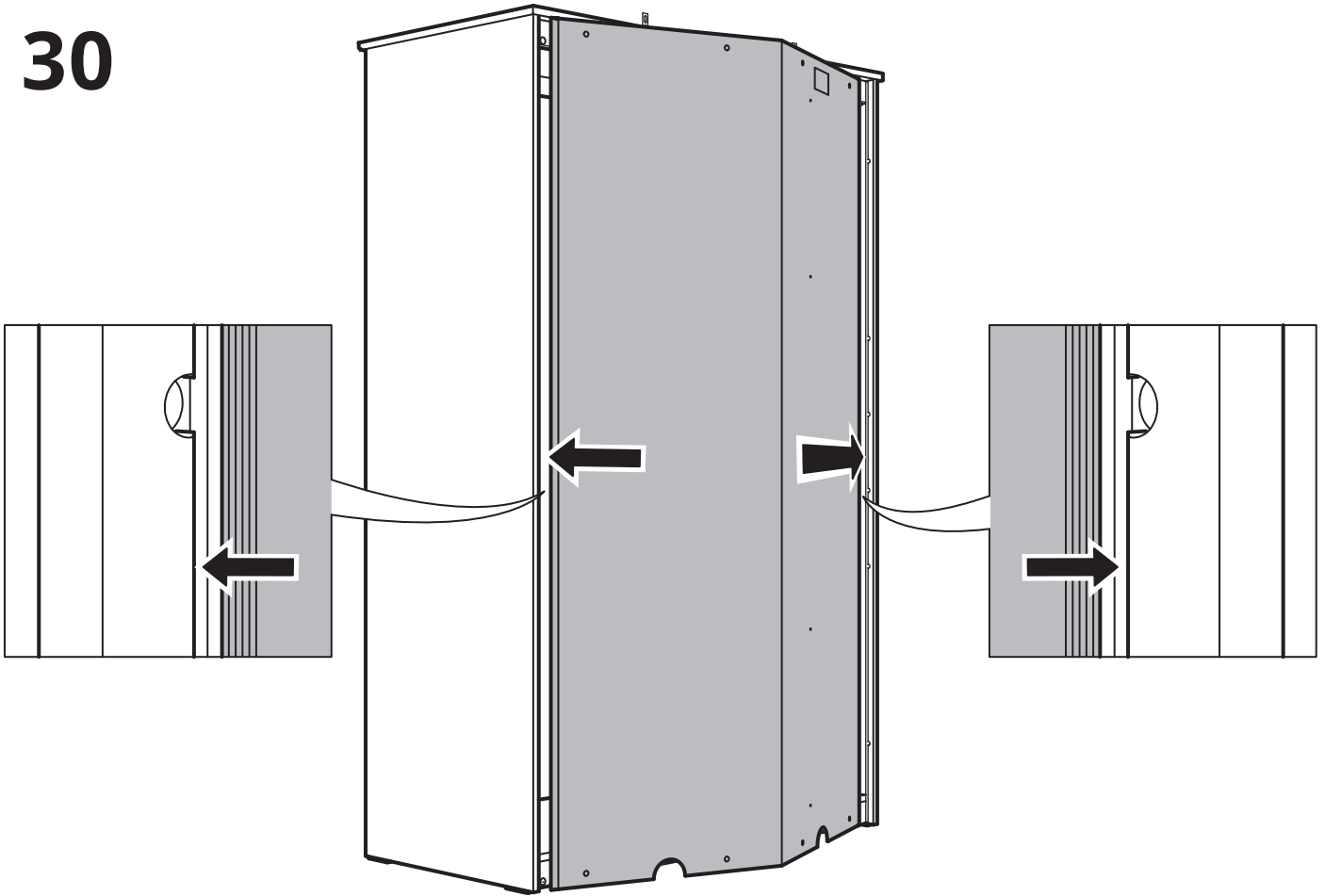

31

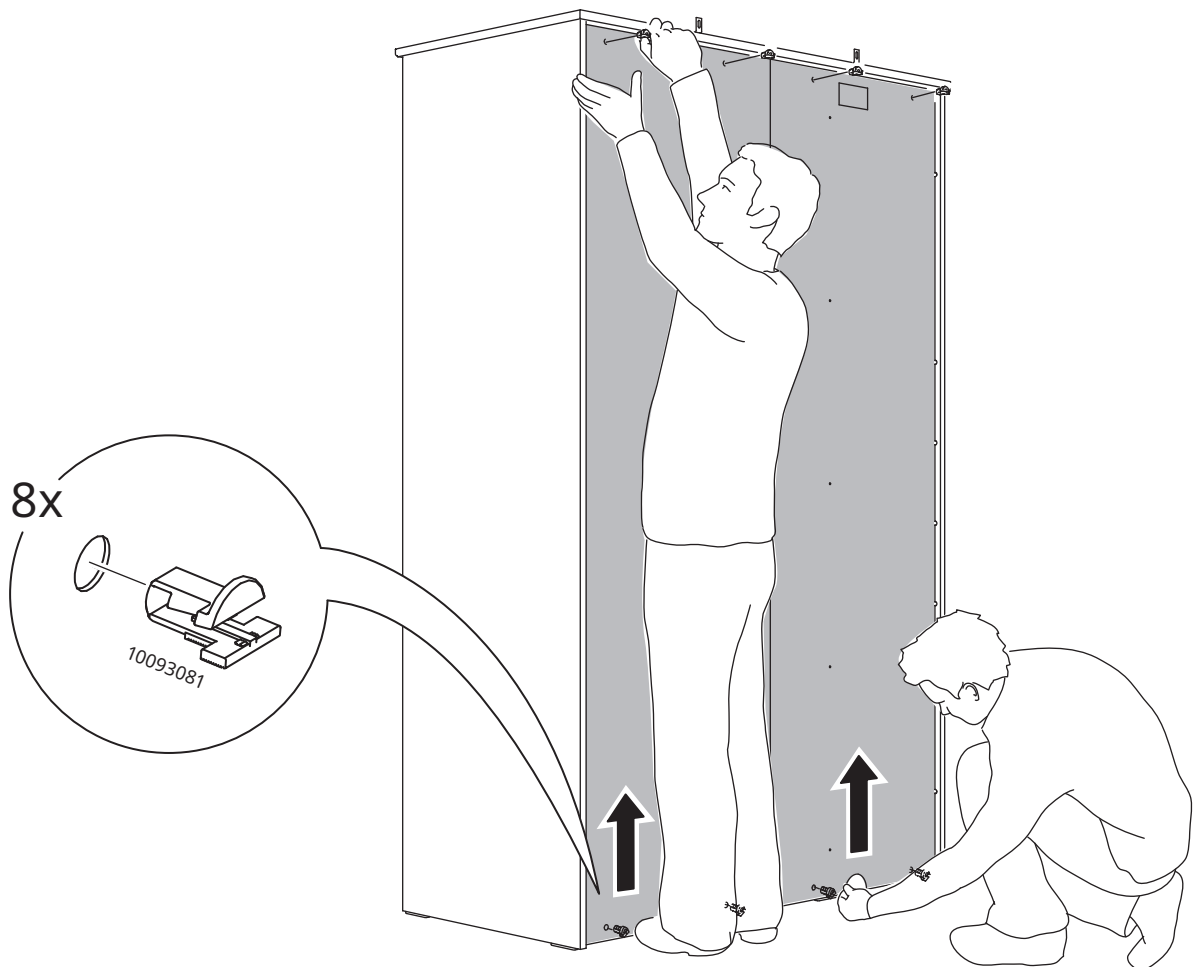

32

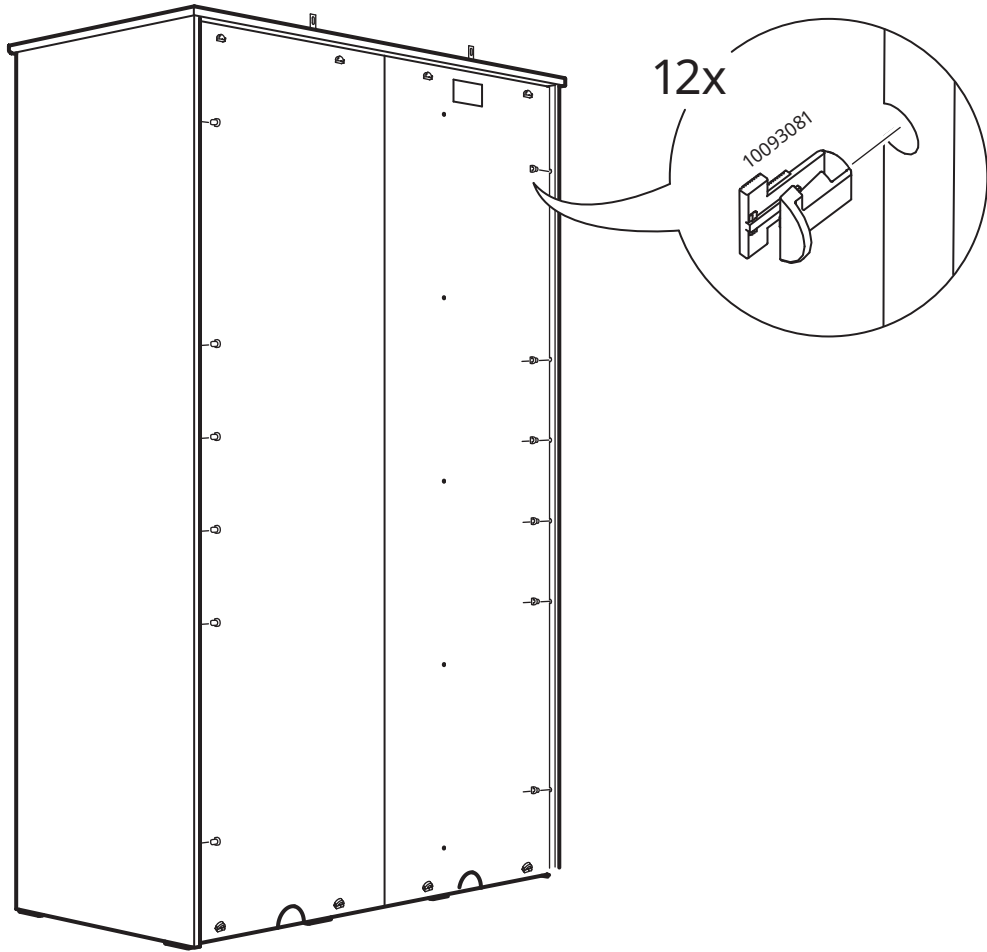

33

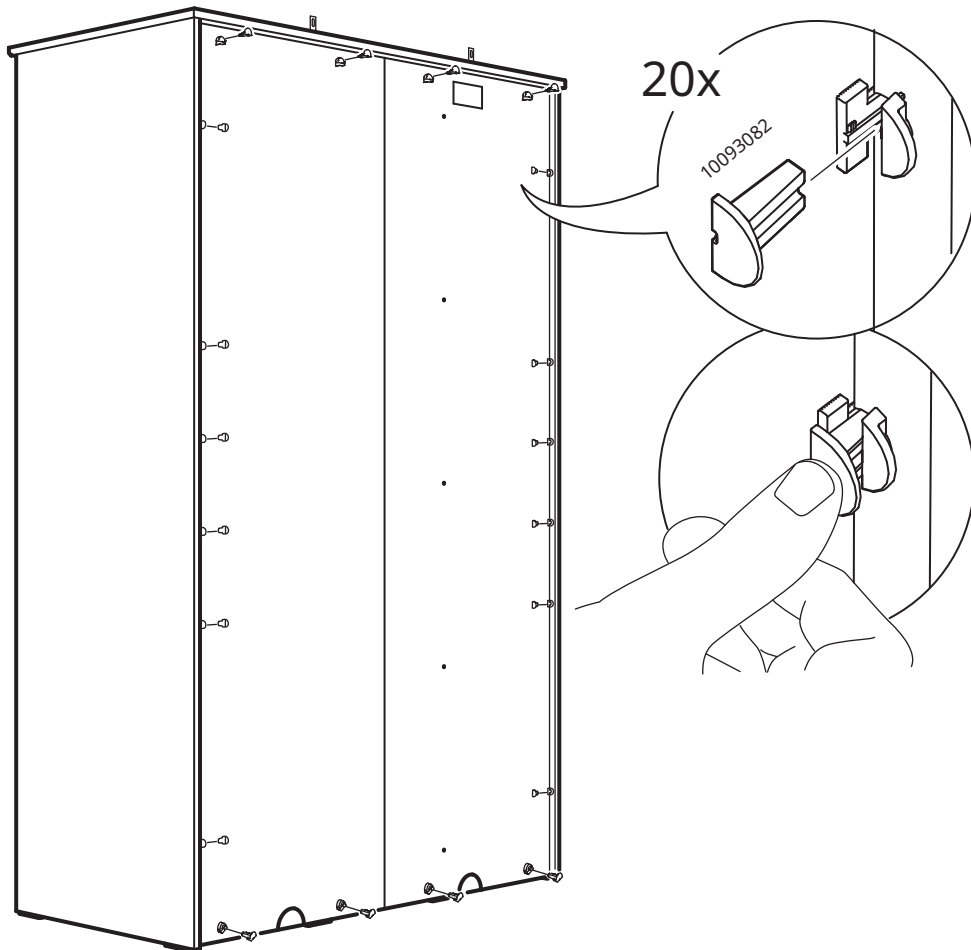

# 34

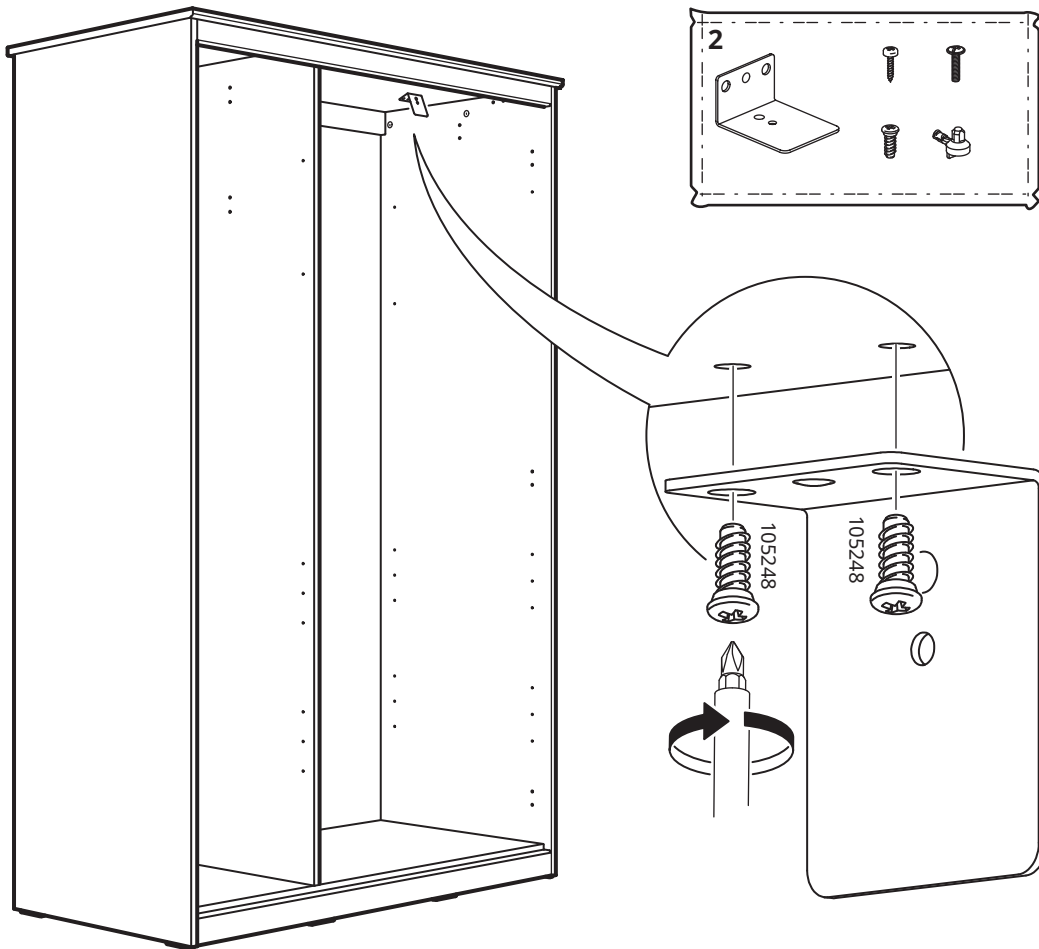
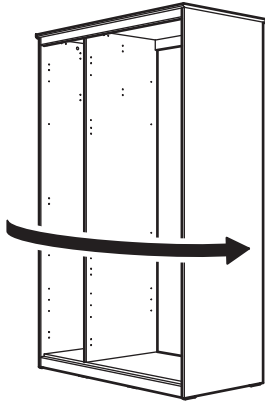

159129  
114246

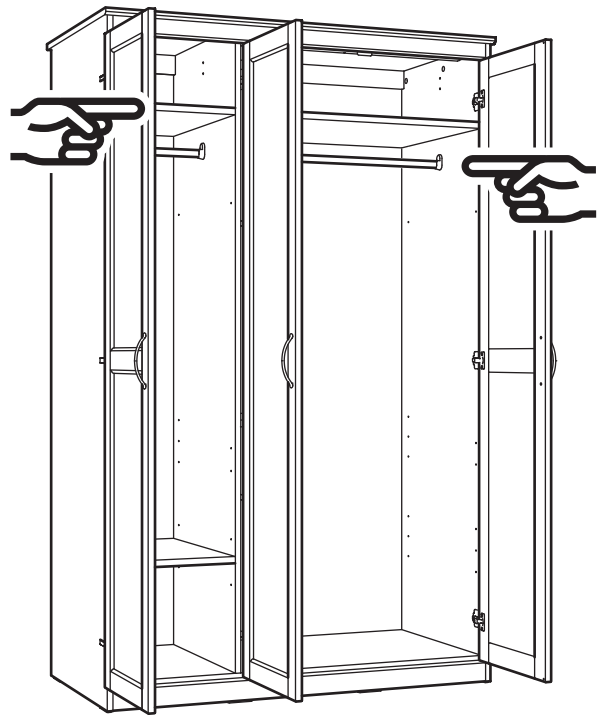
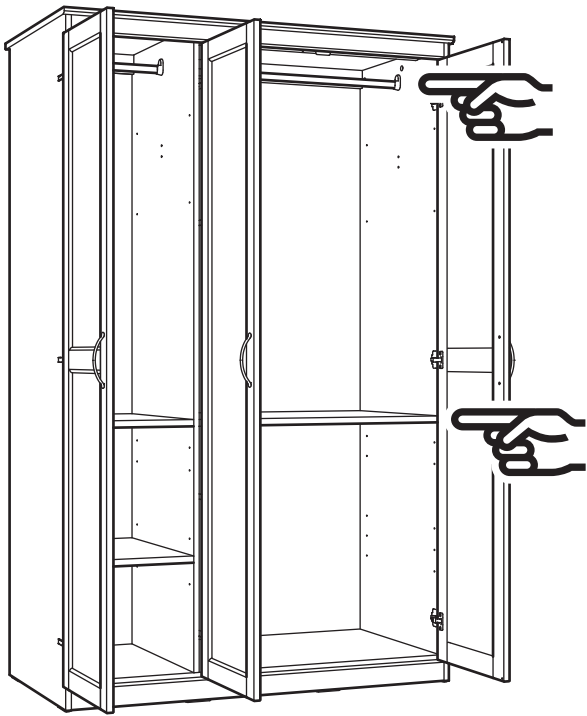

35

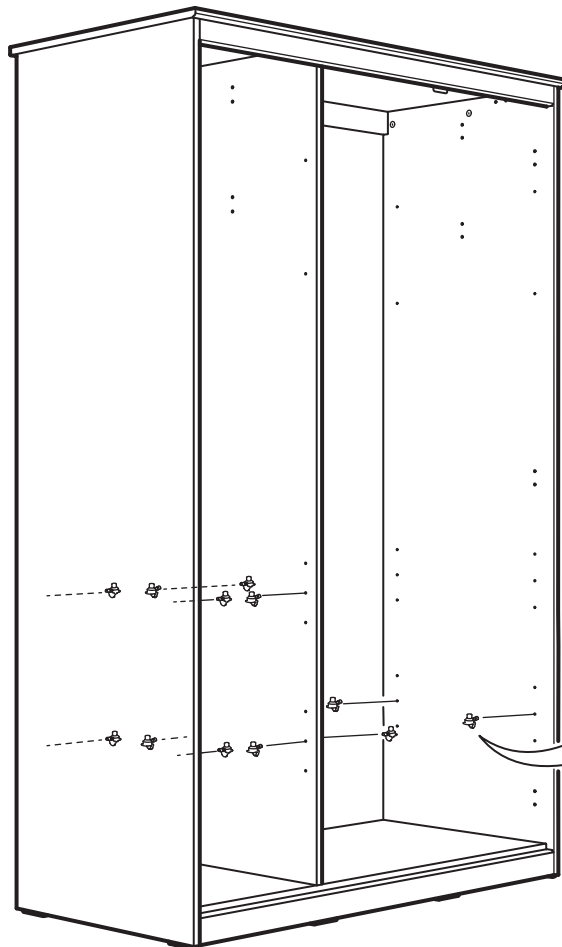

12x

131372

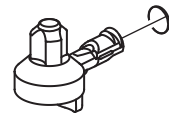

36

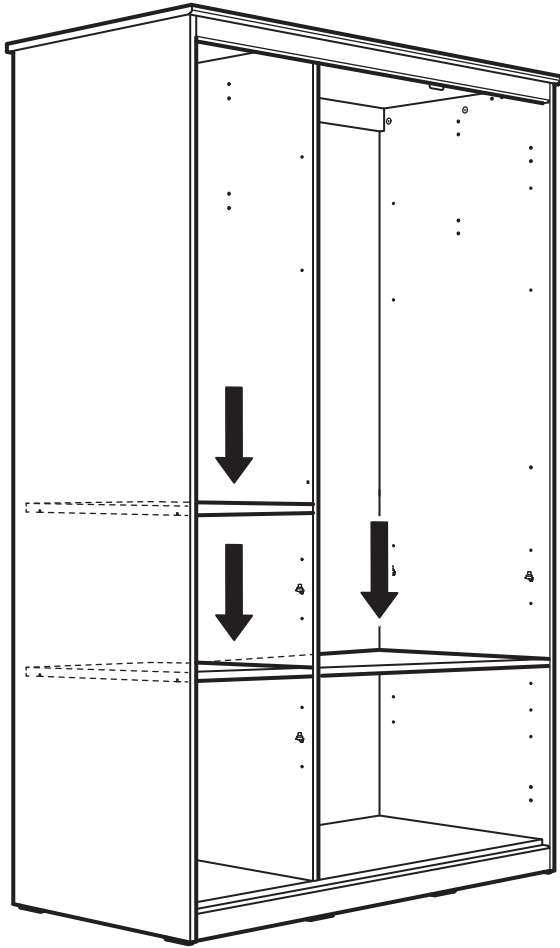

i

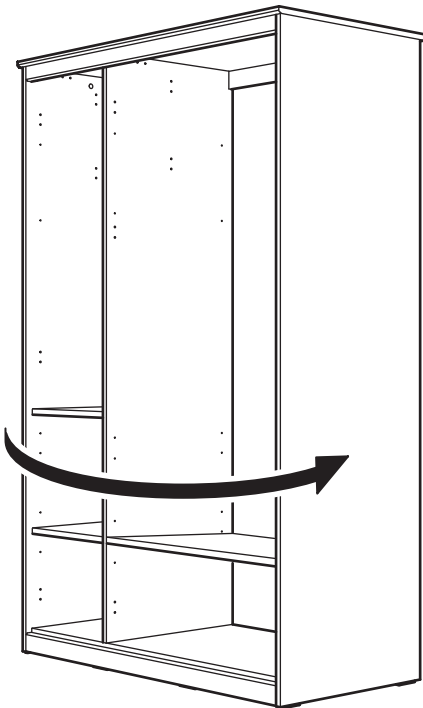
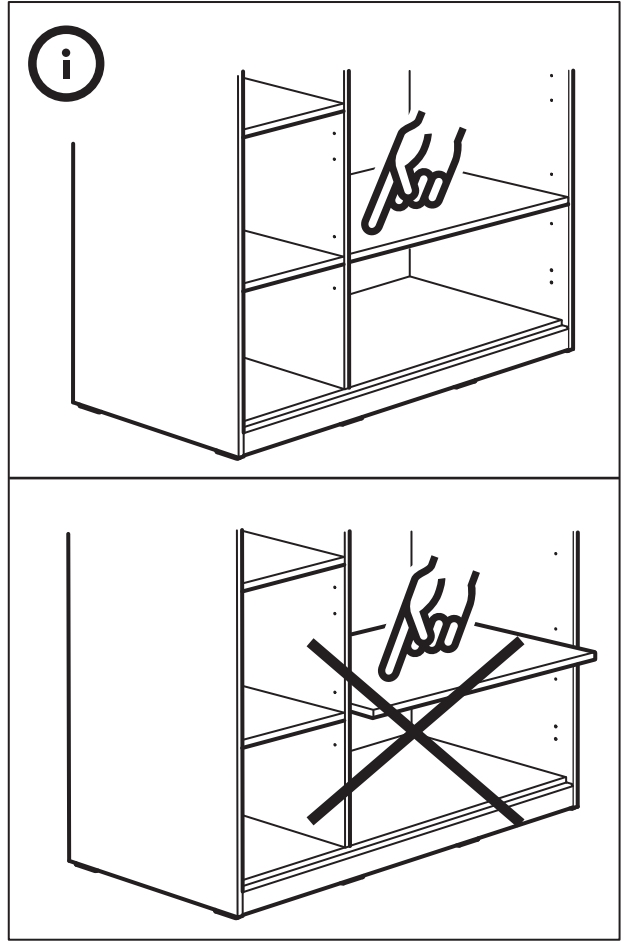

37

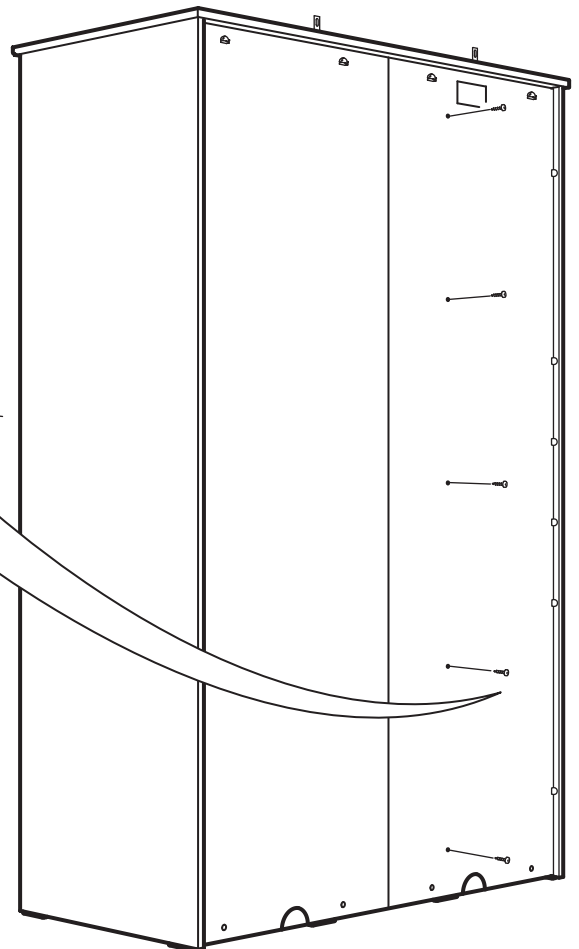
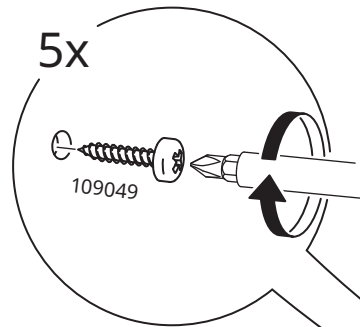

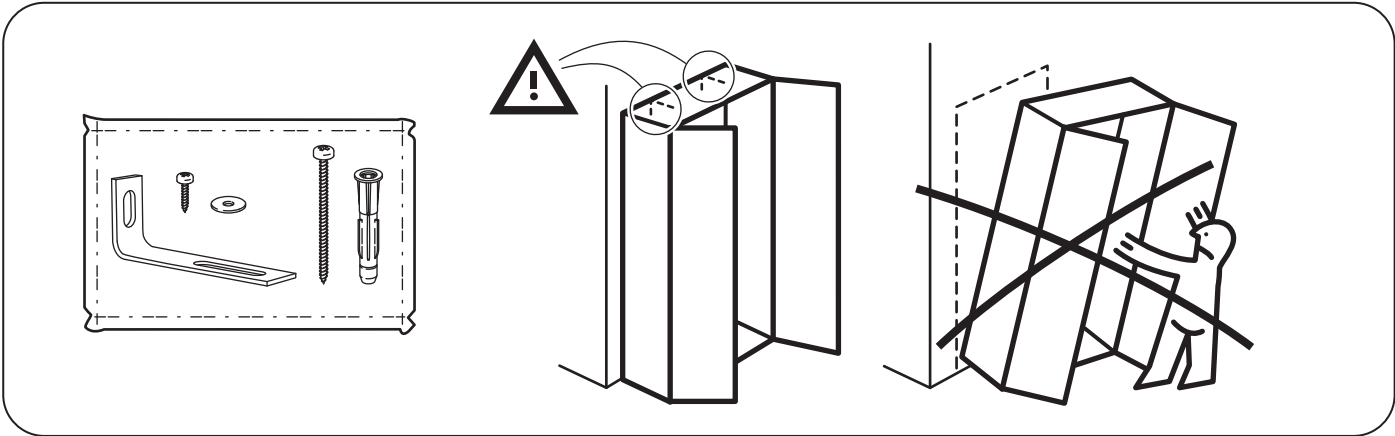

**38**

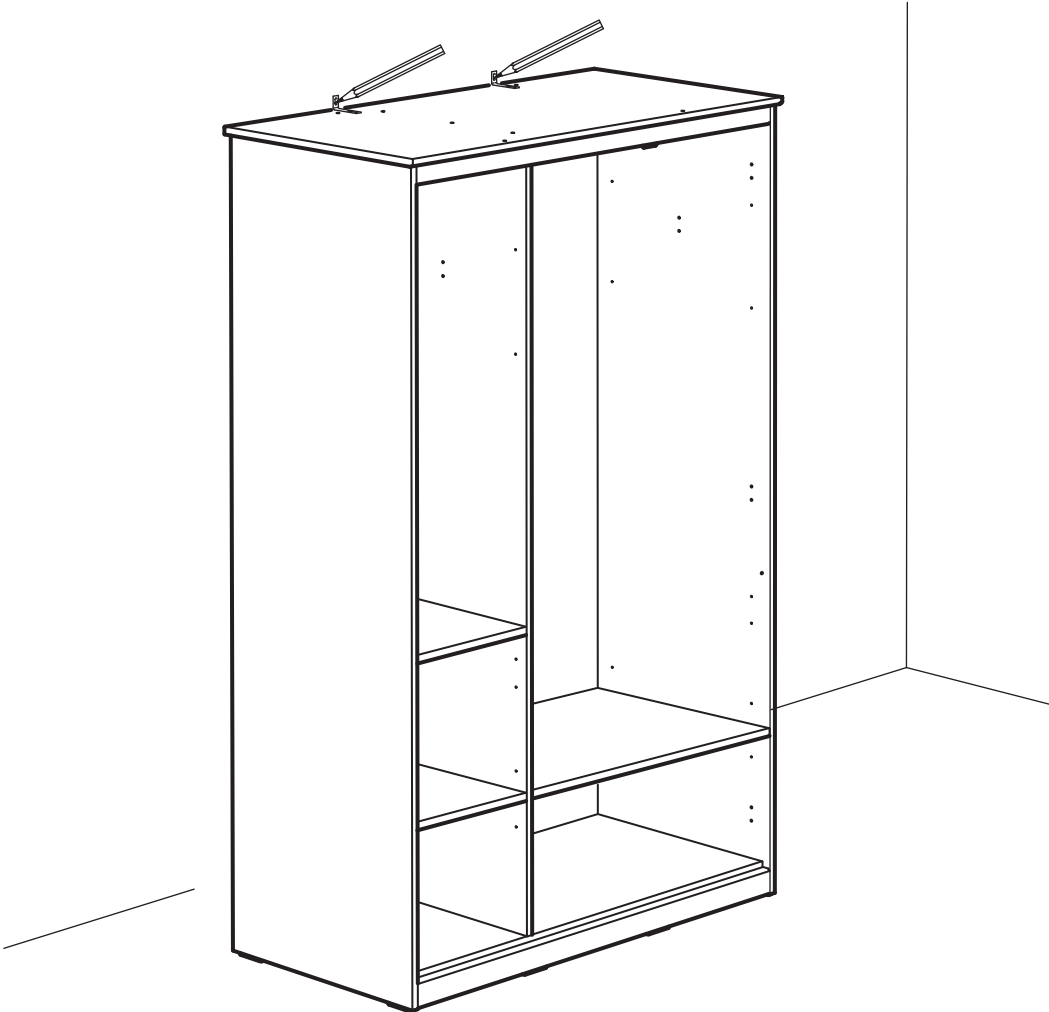
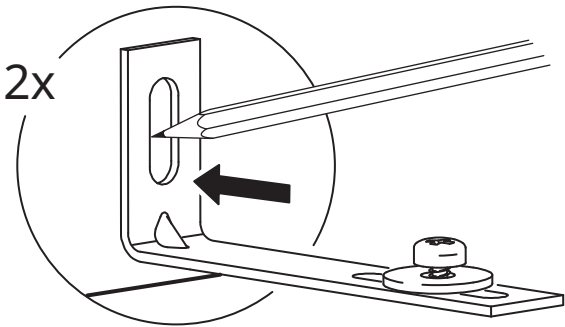
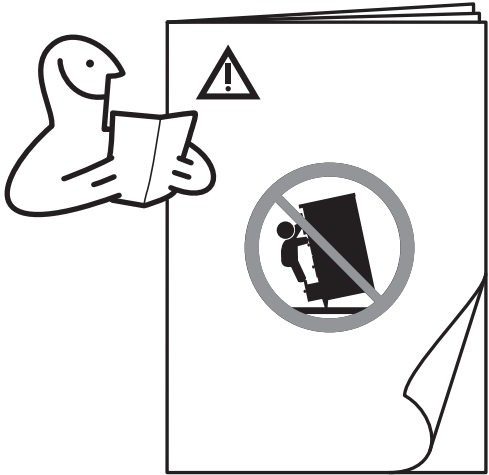

39

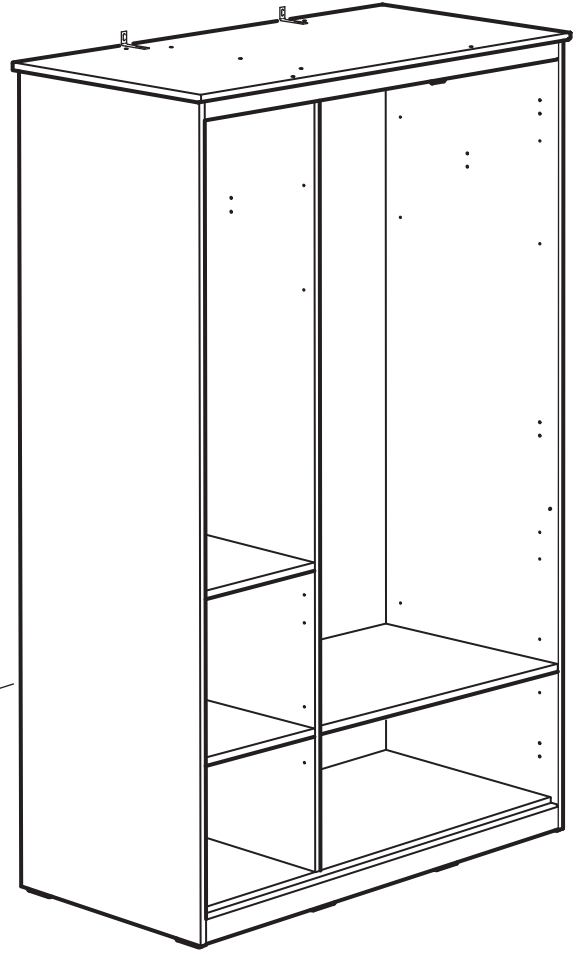
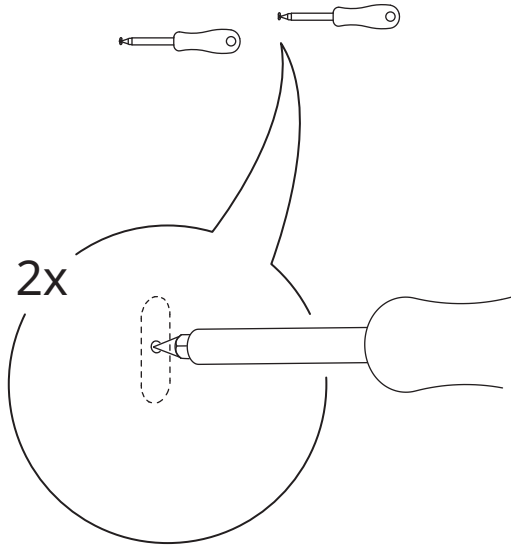

40

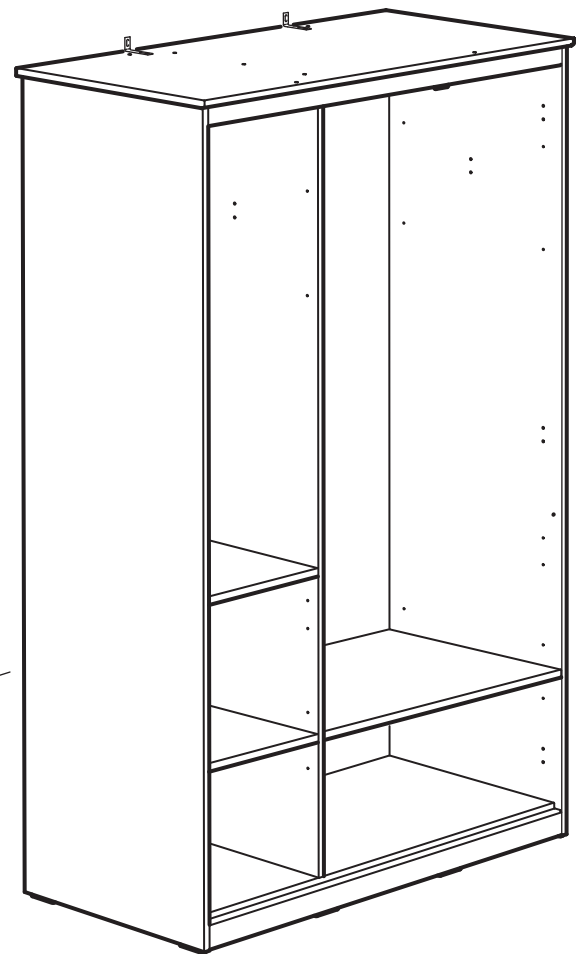
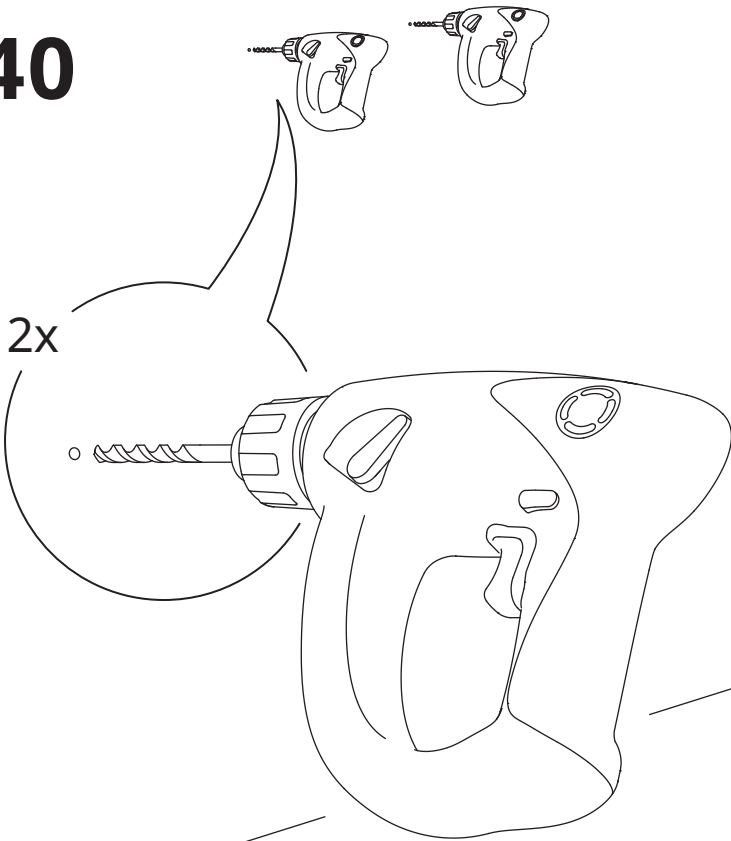

# 41

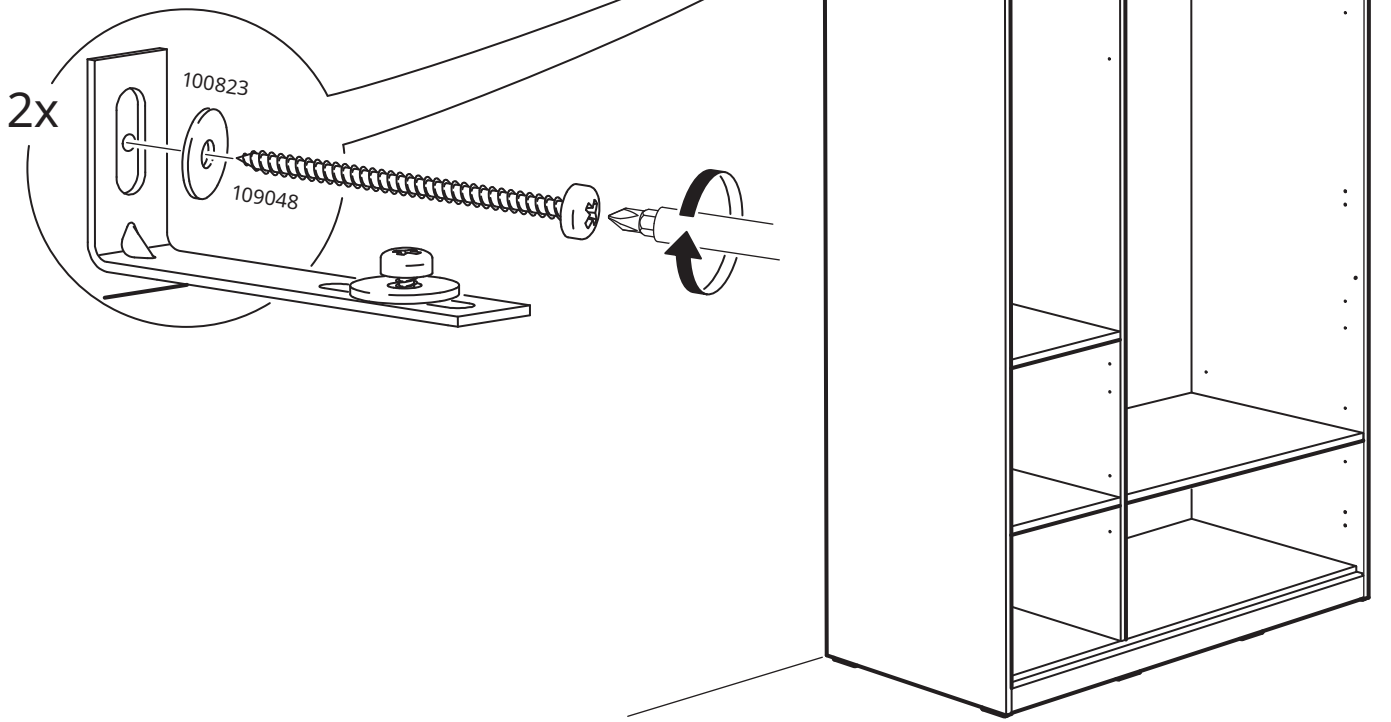

# 42

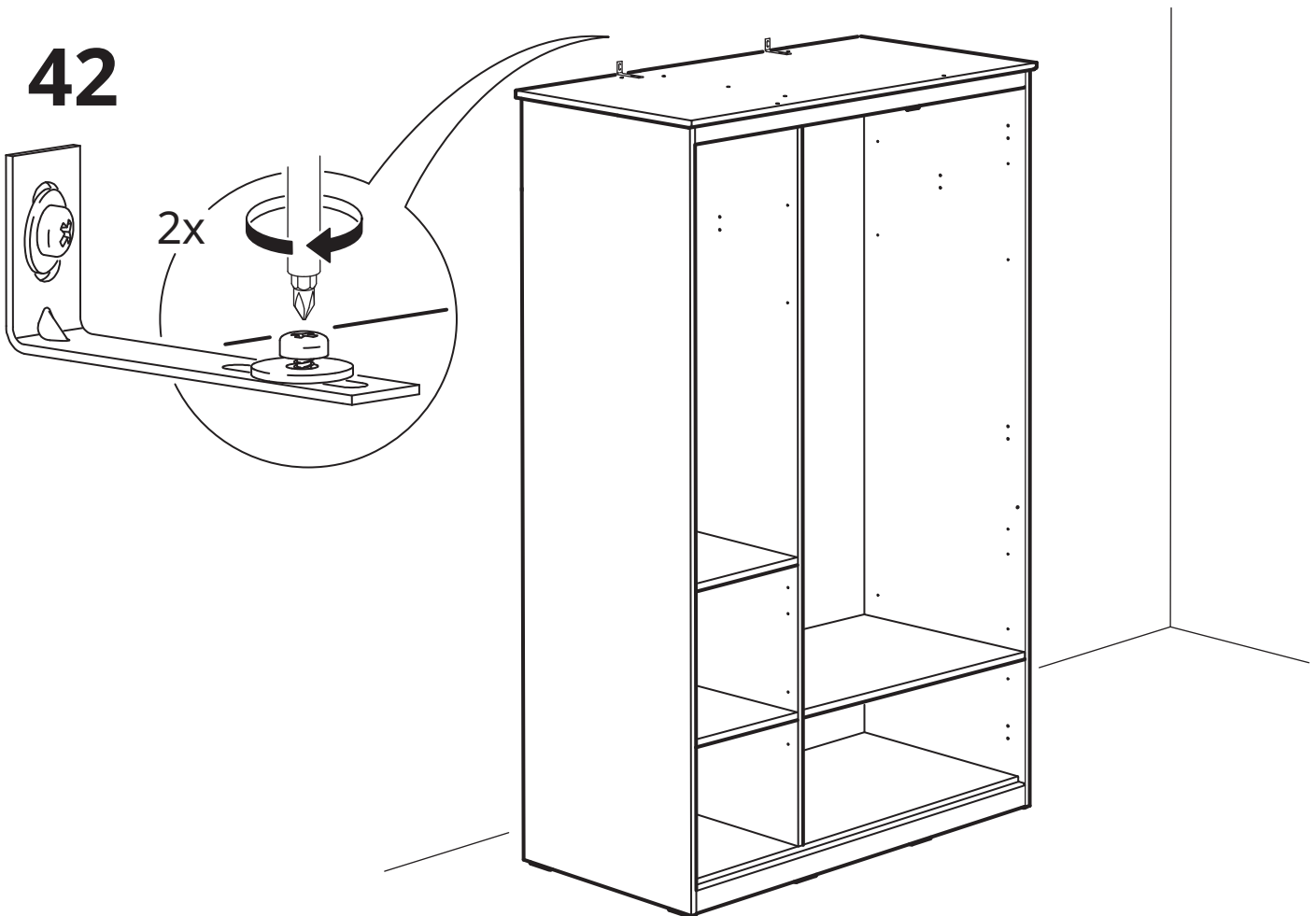

43

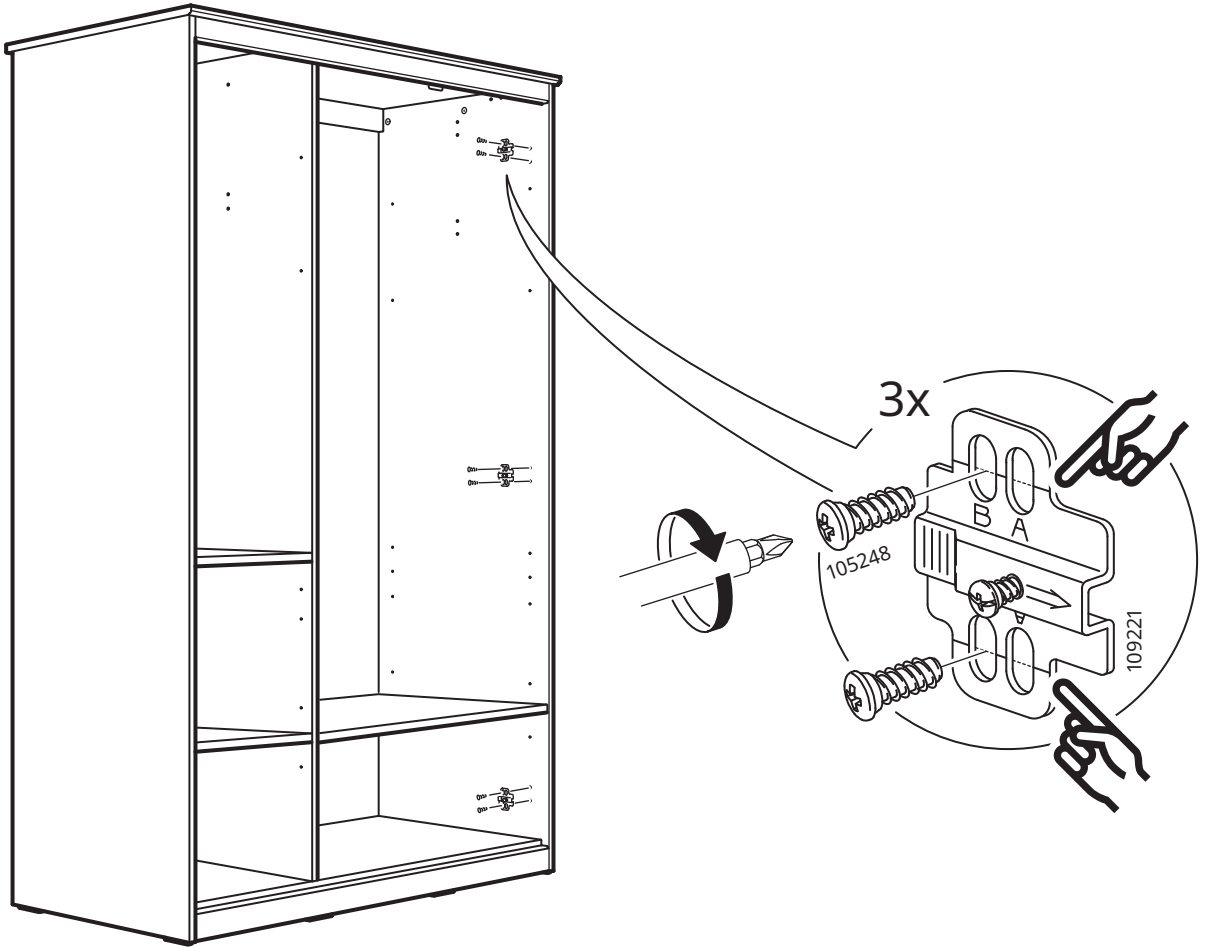

44

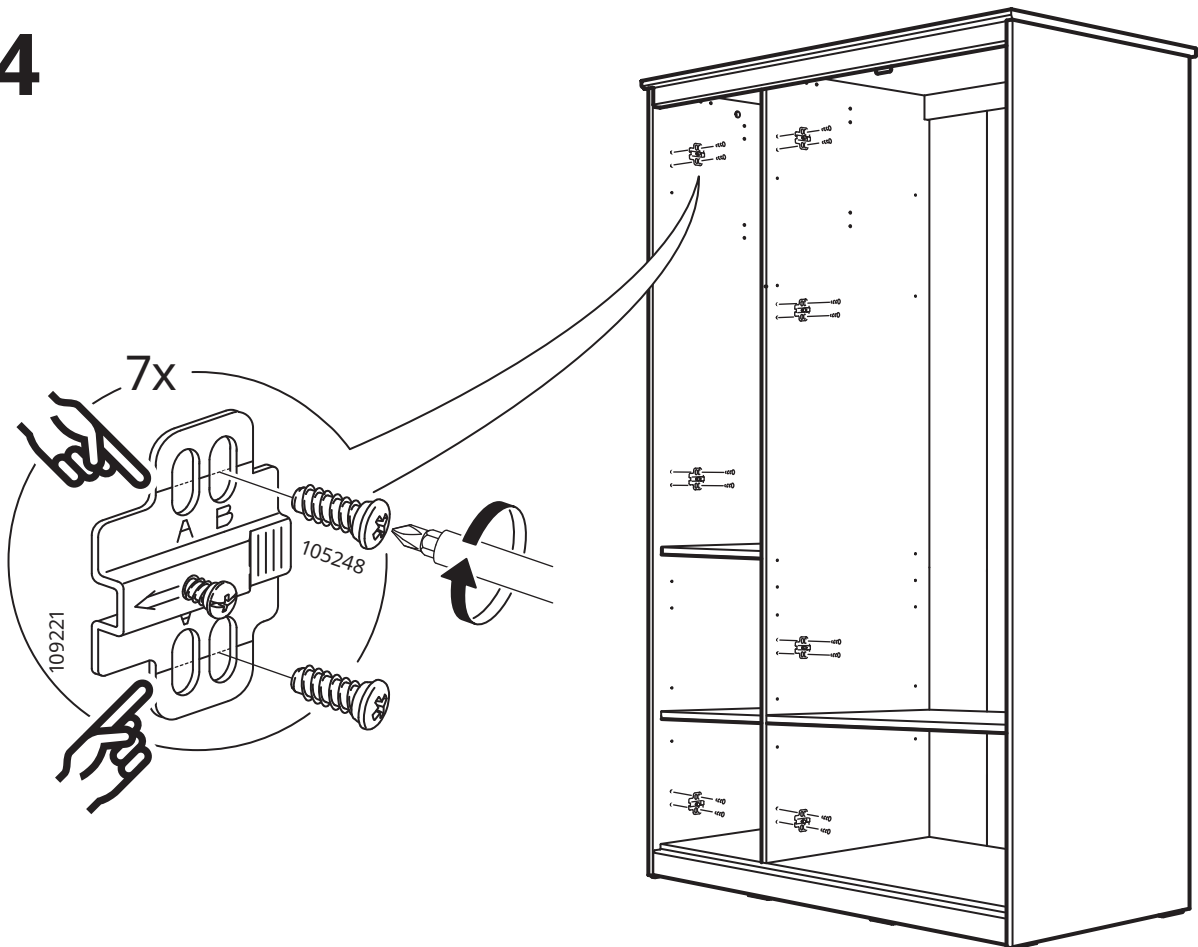

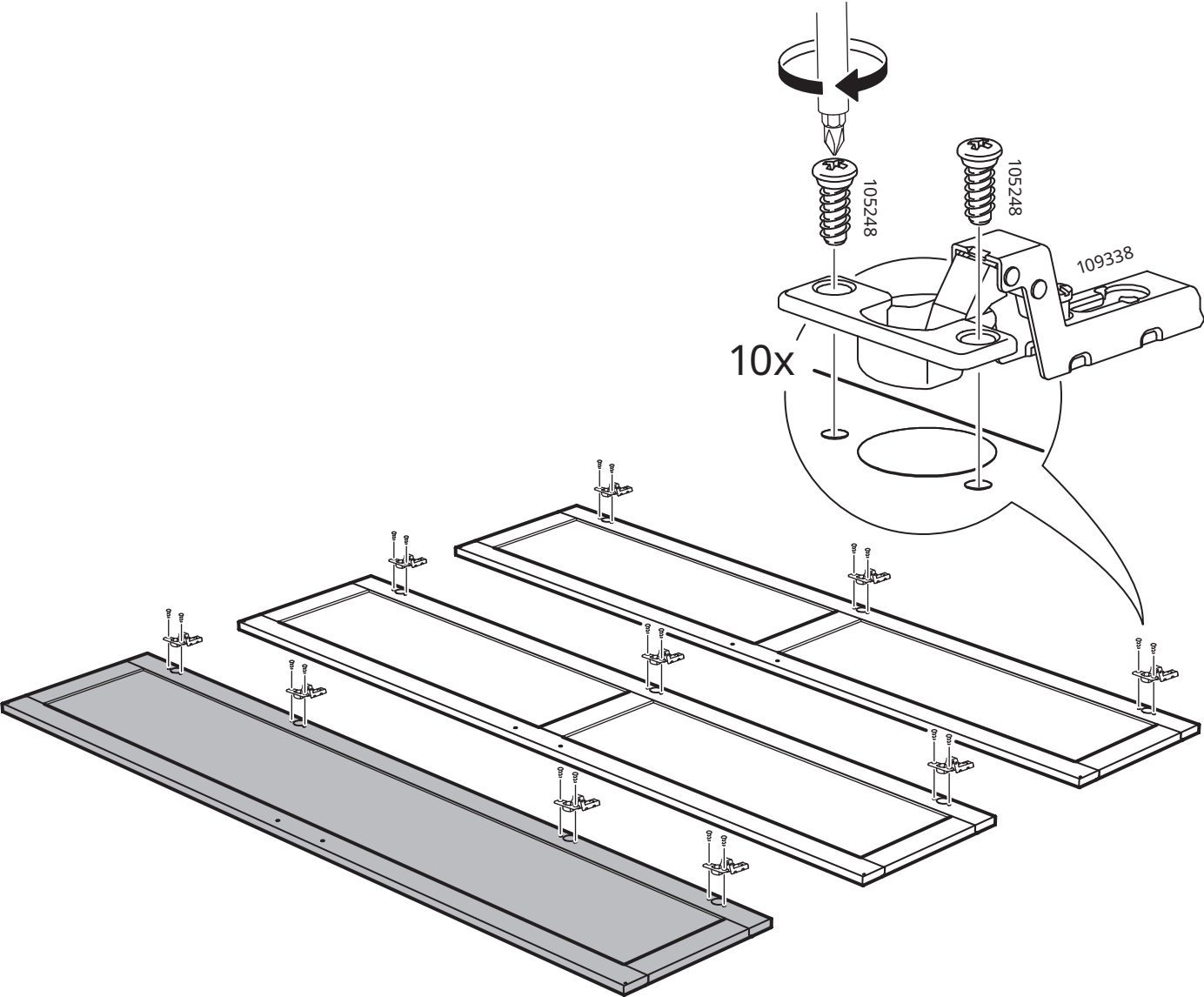

46

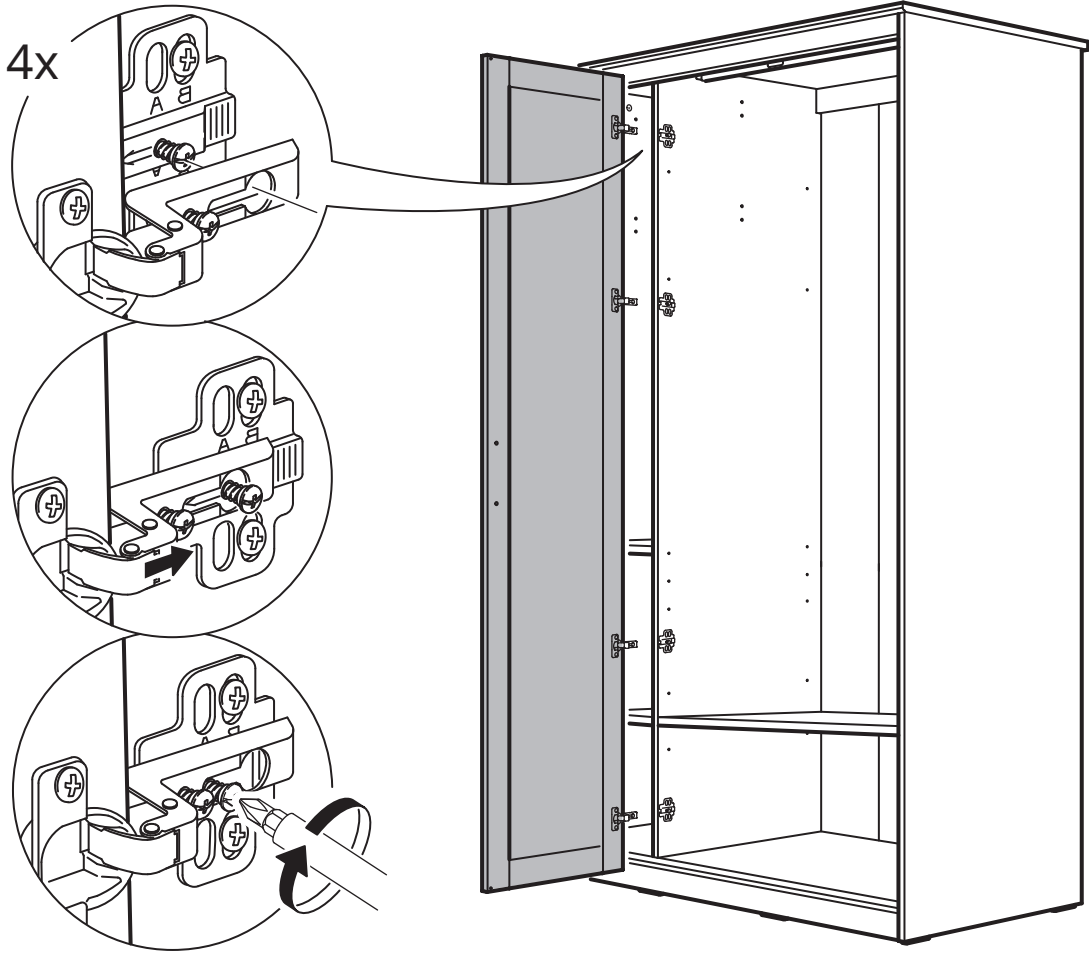

47

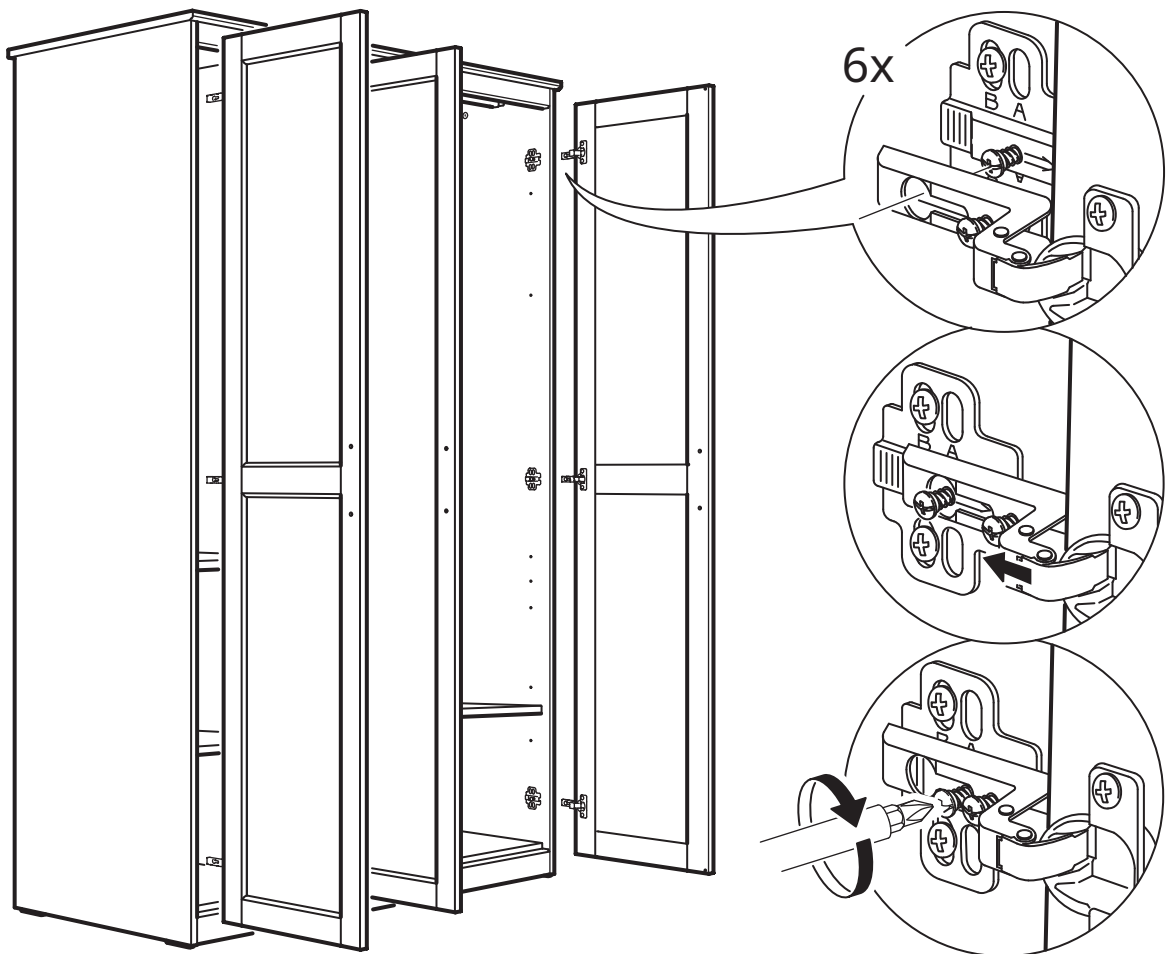

48

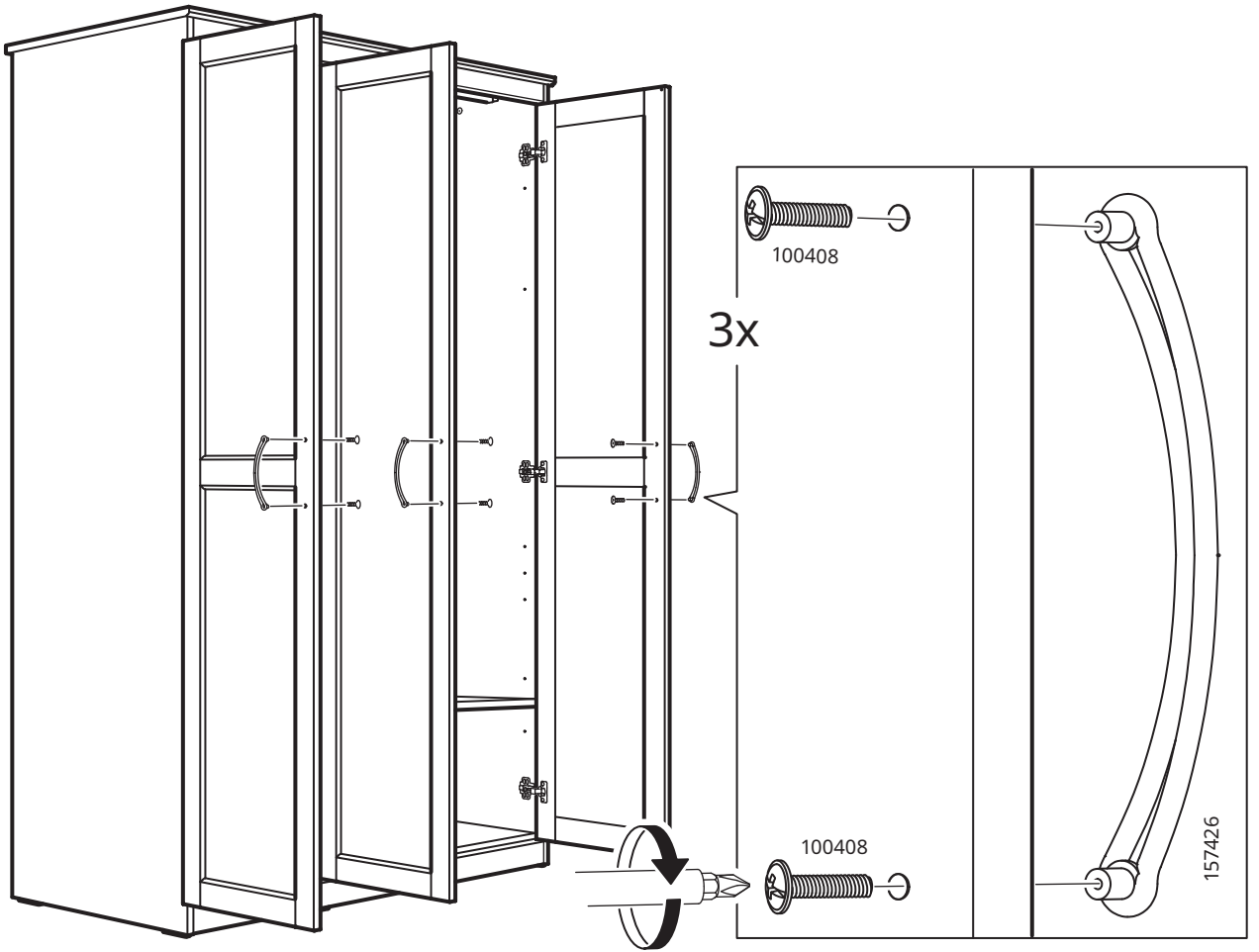

49

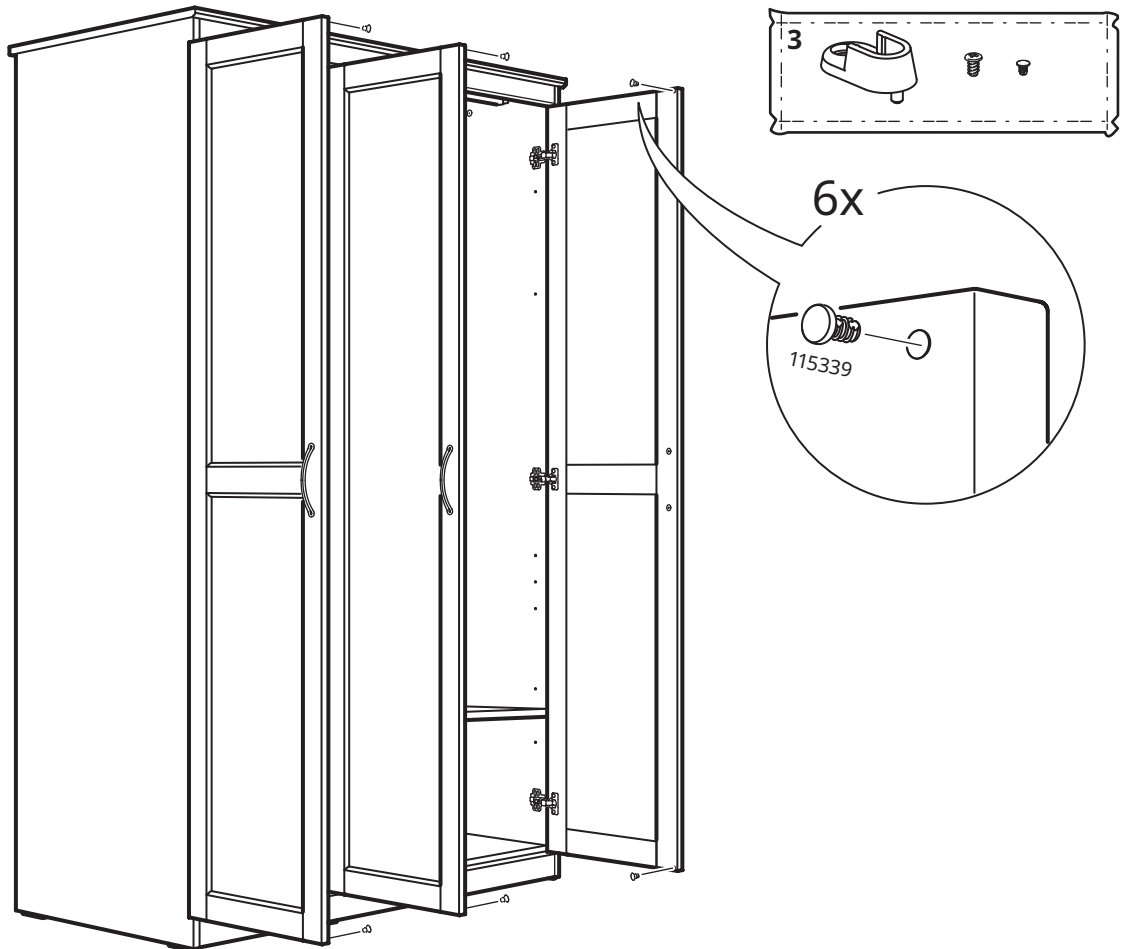

50

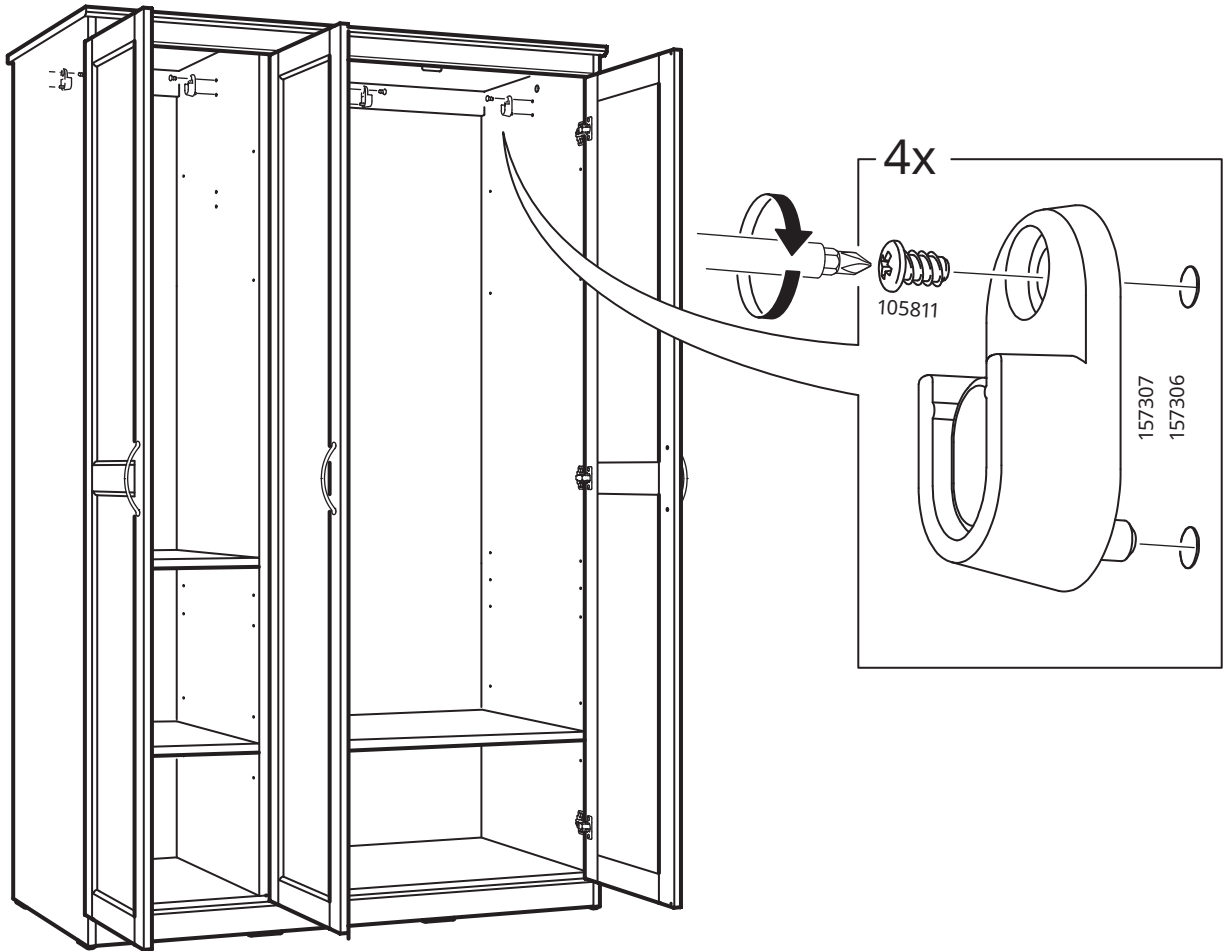

51

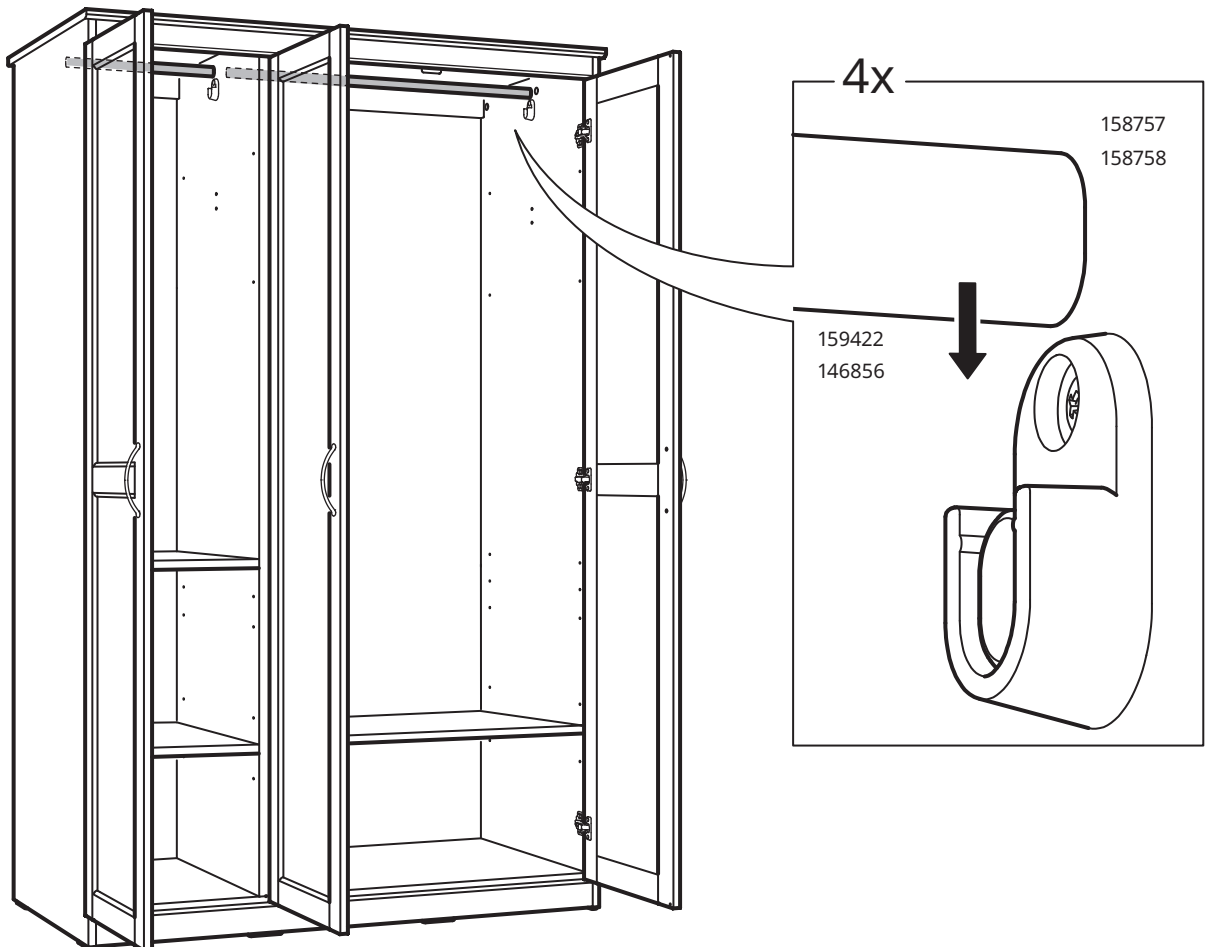

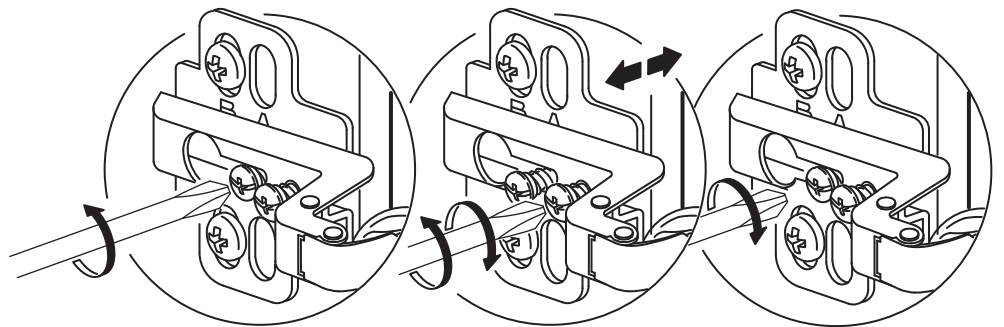
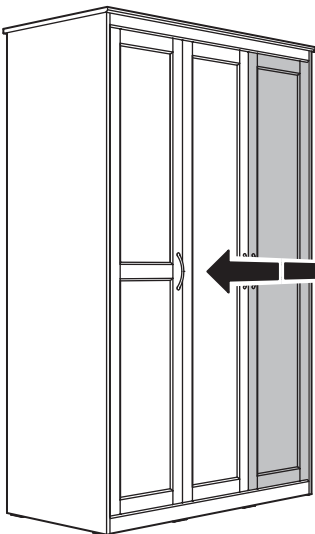
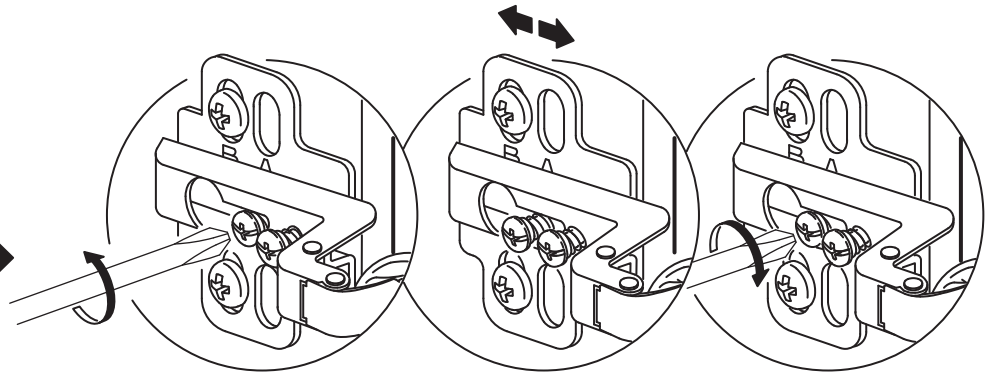
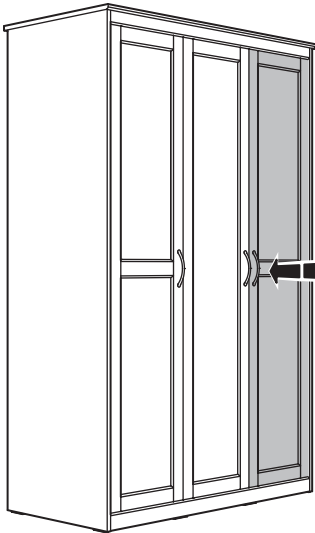
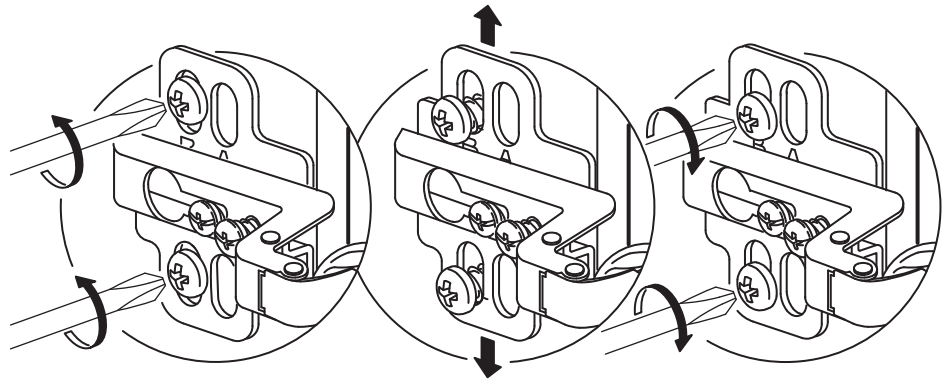
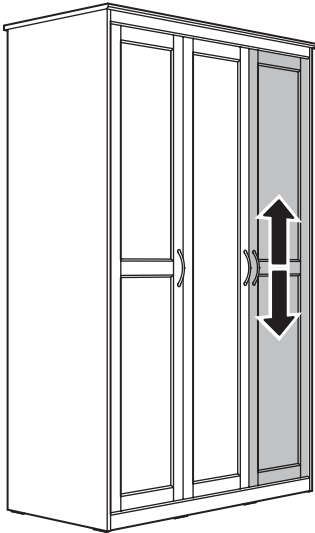

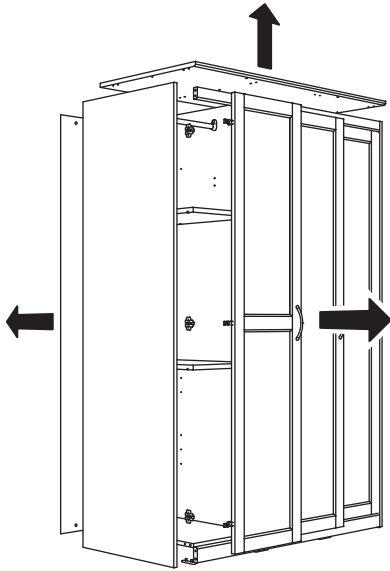

**50 → 1**

