

# METHOD

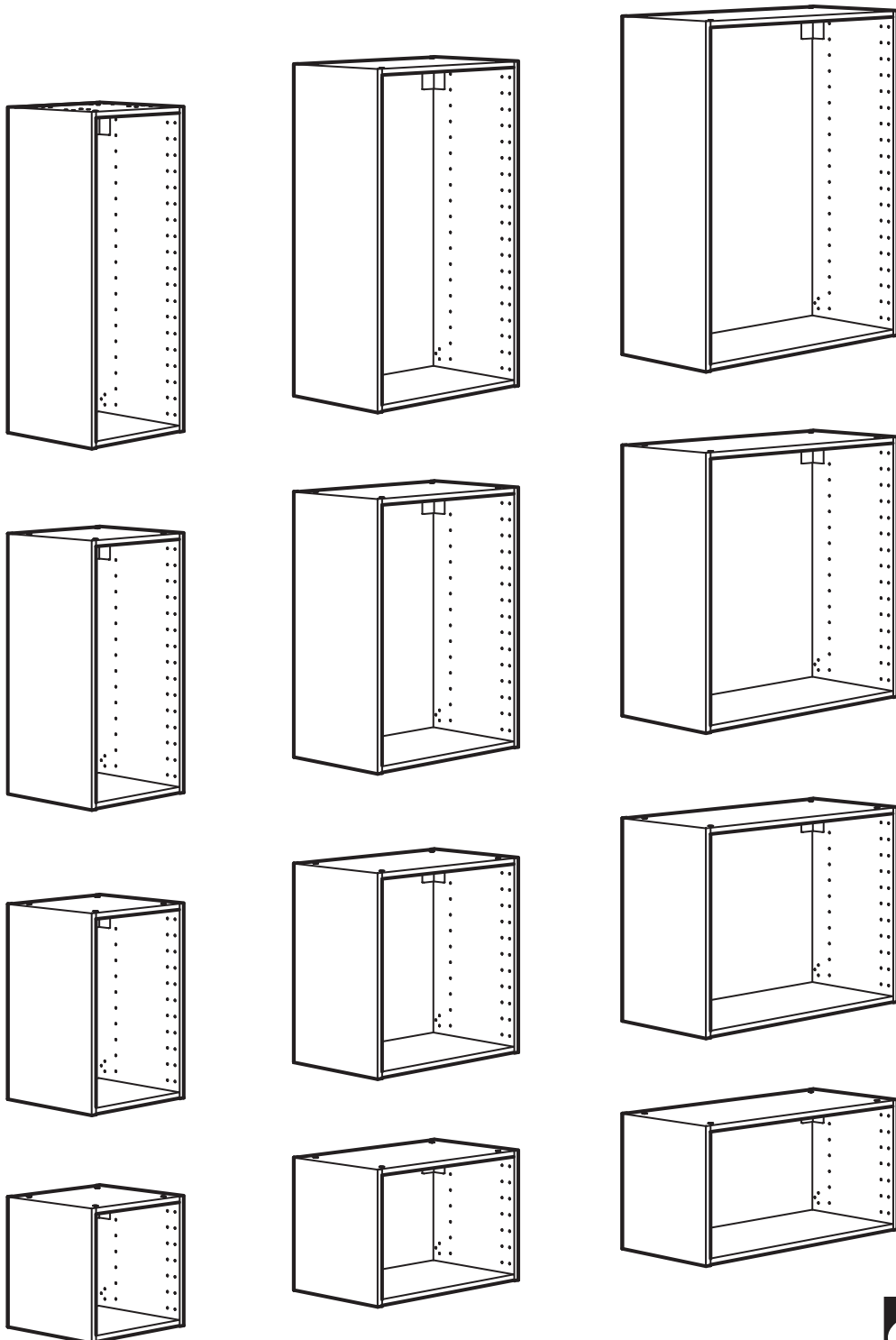

Design and Quality  
IKEA of Sweden



Español

## ATENCIÓN

**Existe un riesgo de daño grave en caso de caída del mueble. Para evitarlo, se debe fijar a la pared con los dispositivos de fijación proporcionados.**

Los tornillos y los tacos no se incluyen. Comprueba si la pared es lo suficientemente estable como para soportar las fuerzas generadas. Utiliza los tornillos y tacos adecuados para tu pared y la carga. Si tienes dudas, ponte en contacto con un especialista. Lee y sigue correctamente los pasos indicados en las instrucciones.

Català

## ATENCIÓ

**Hi ha un risc de dany greu en cas de caiguda del moble. Per evitar-ho, s'ha de fixar a la paret amb els dispositius de fixació proporcionats.**

Els cargols i els tacs no s'inclouen. Comprova si la paret és prou estable com per suportar les forces generades. Utilitza els cargols i tacs adequats per a la teva paret i la càrrega. Si tens dubtes, posa't en contacte amb un especialista. Llegeix i segueix correctament els passos indicats a les instruccions.

Euskara

## ABISUA!

**Zapaltze-lesio larriak edo hilgarriak gerta daitezke altzaria erortzen bada. Emandako hormarako euskarriak erabili behar dira altzari hau erori ez dadin.**

Hormarako torlojuak eta takoak ez daude barne. Ziurtatu horma egokia dela eutsi beharreko pisua jasateko. Erabili hormarako eta jarriko den kargarako egokiak diren torlojuak eta takoak. Ziur ez bazaude, galdetu profesional bati. Irakurri arretaz eta jarraitu argibideetako urrats bakoitzari.

Galego

## ADVERTENCIA!

**Se un mueble case, pode causar lesións graves ou letais. Para evitar que caia, este mueble debe usarse cos dispositivos de fixación á parede fornecidos.**

Os parafusos e os tacos para a parede non están incluídos. Avalía a idoneidade da parede para garantir a súa resistencia ás forzas xeradas. Usa os parafusos e tacos adecuados para as paredes e as cargas previstas. Se non estiveres seguro, busca asesoramento profesional. Le e sigue atentamente cada paso das instrucións.





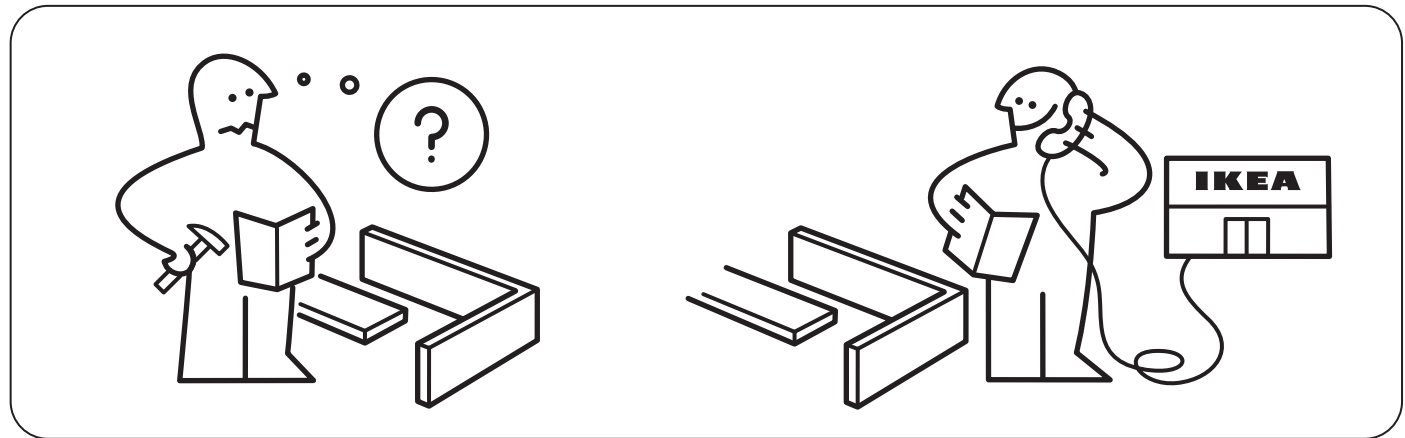
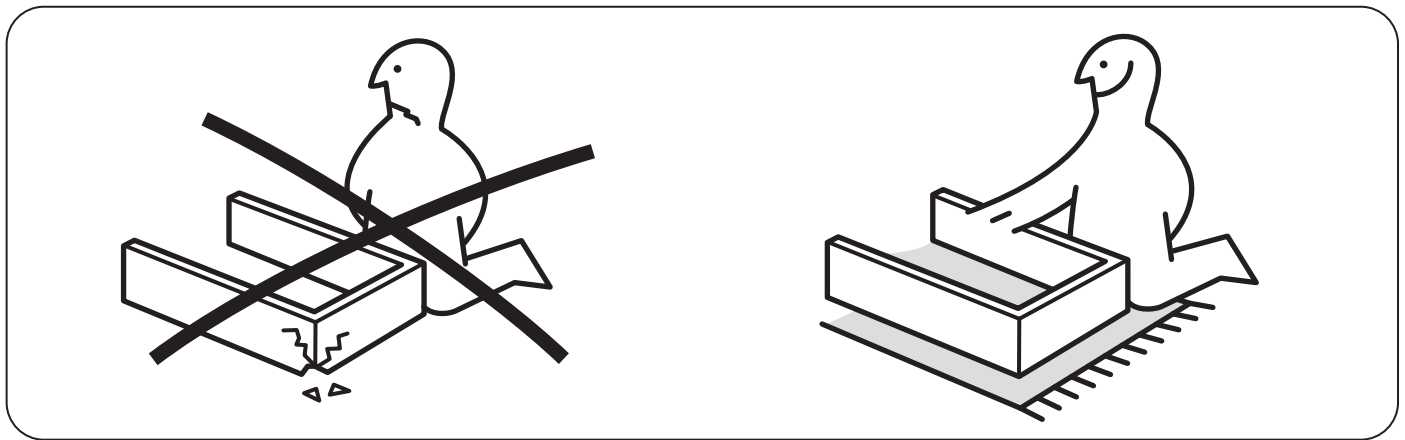
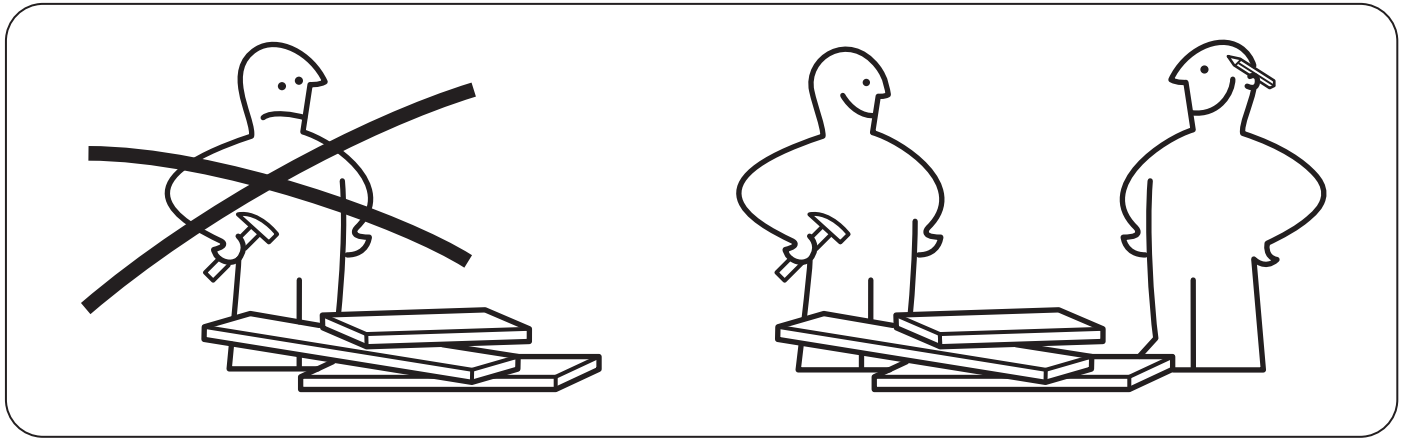
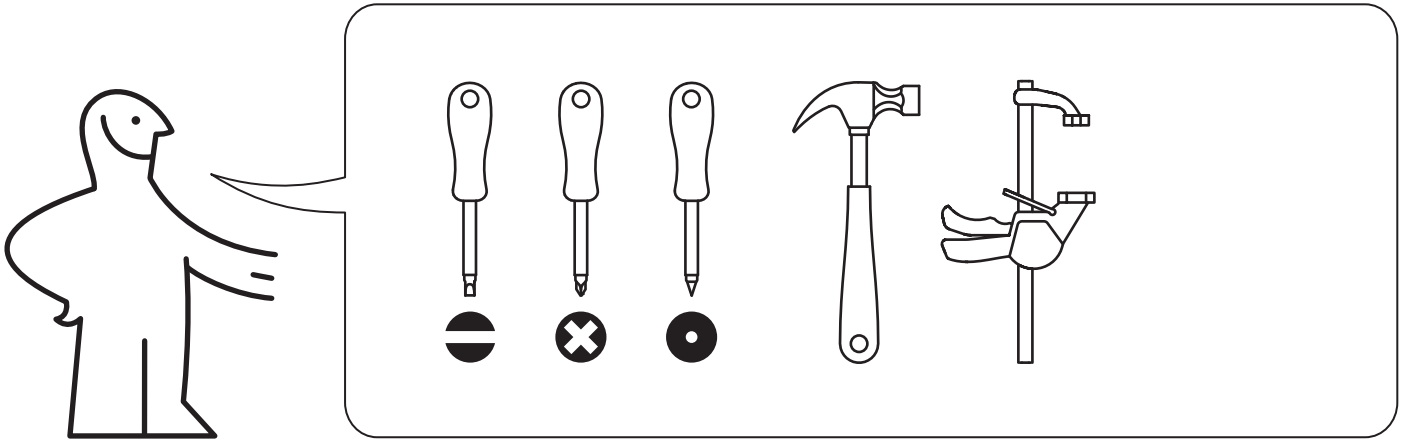



8x

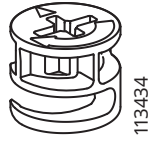

8x



6x

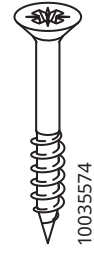

4x



8x

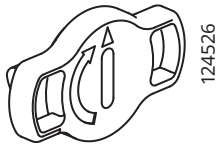

2x

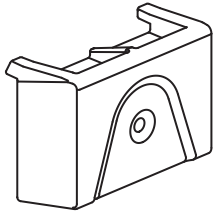

2x

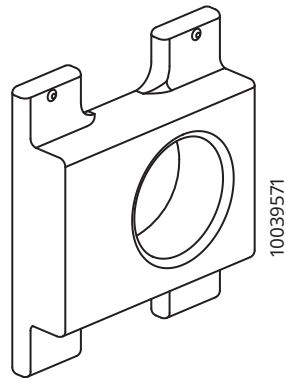

2x

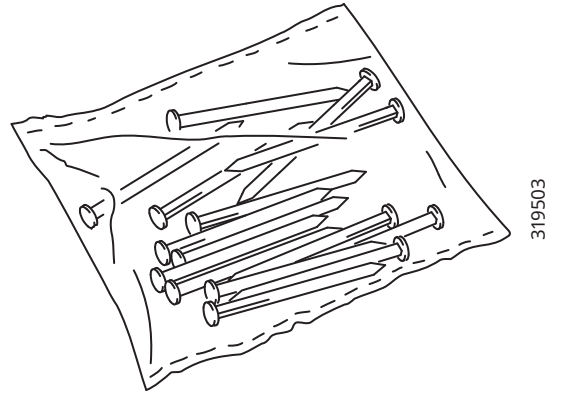

1x

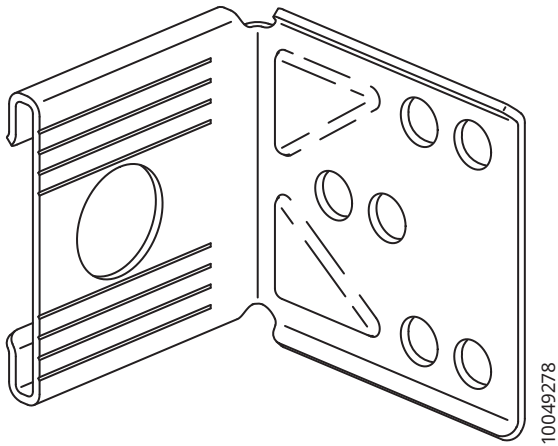

2x

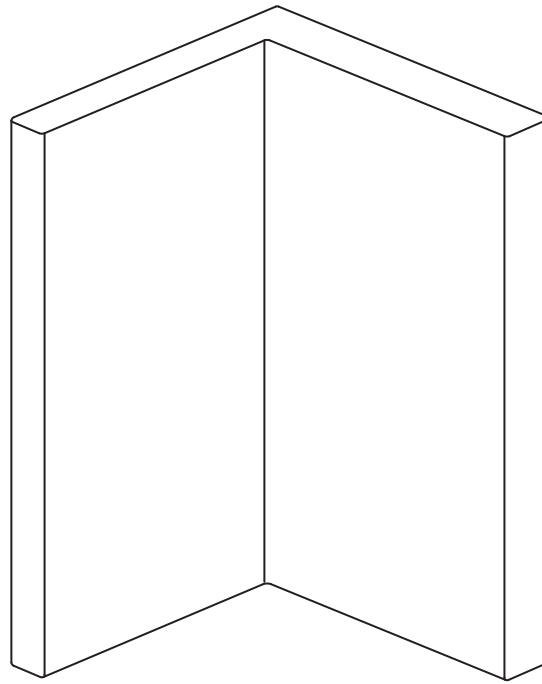

2x

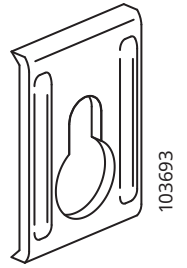
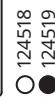

2x

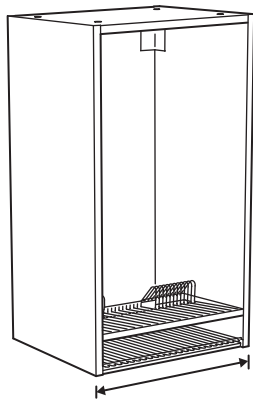
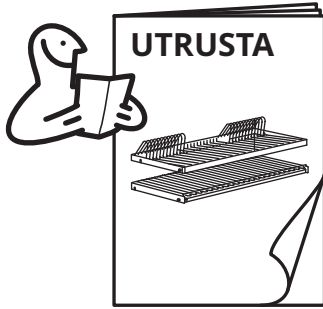

40 cm

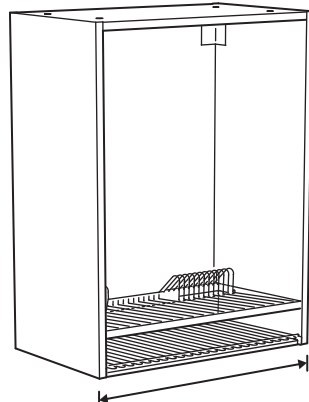

60 cm

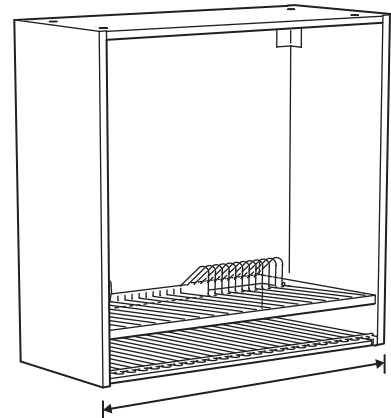

80 cm

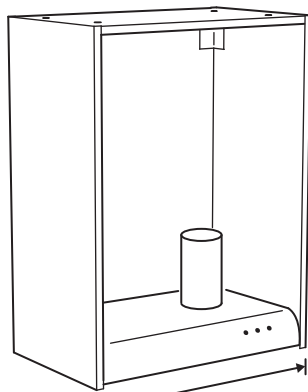
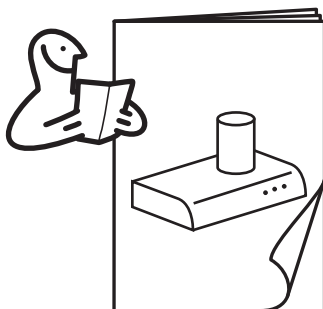

60 cm

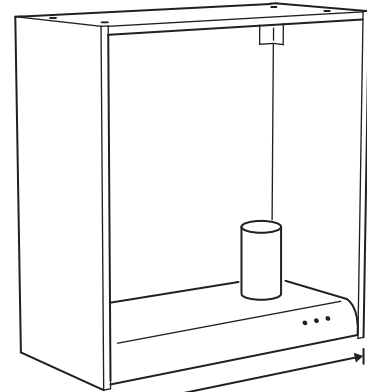

80 cm

1

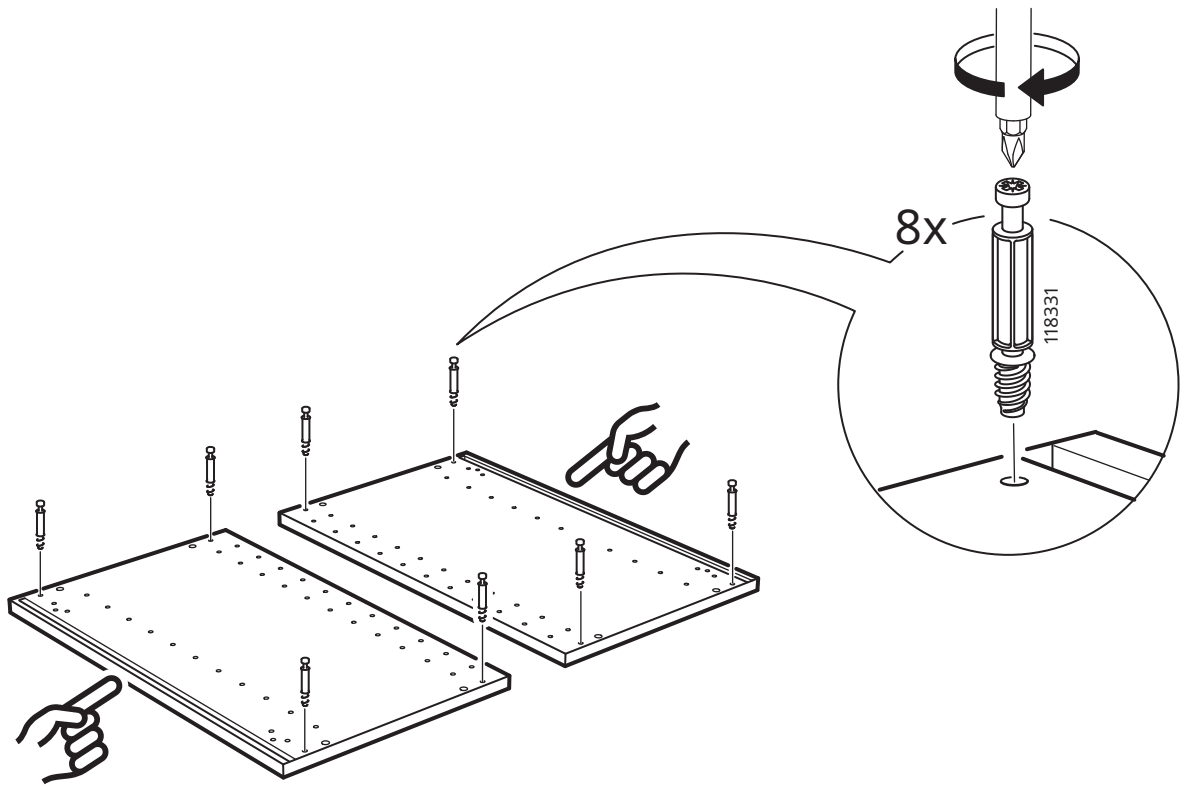

2

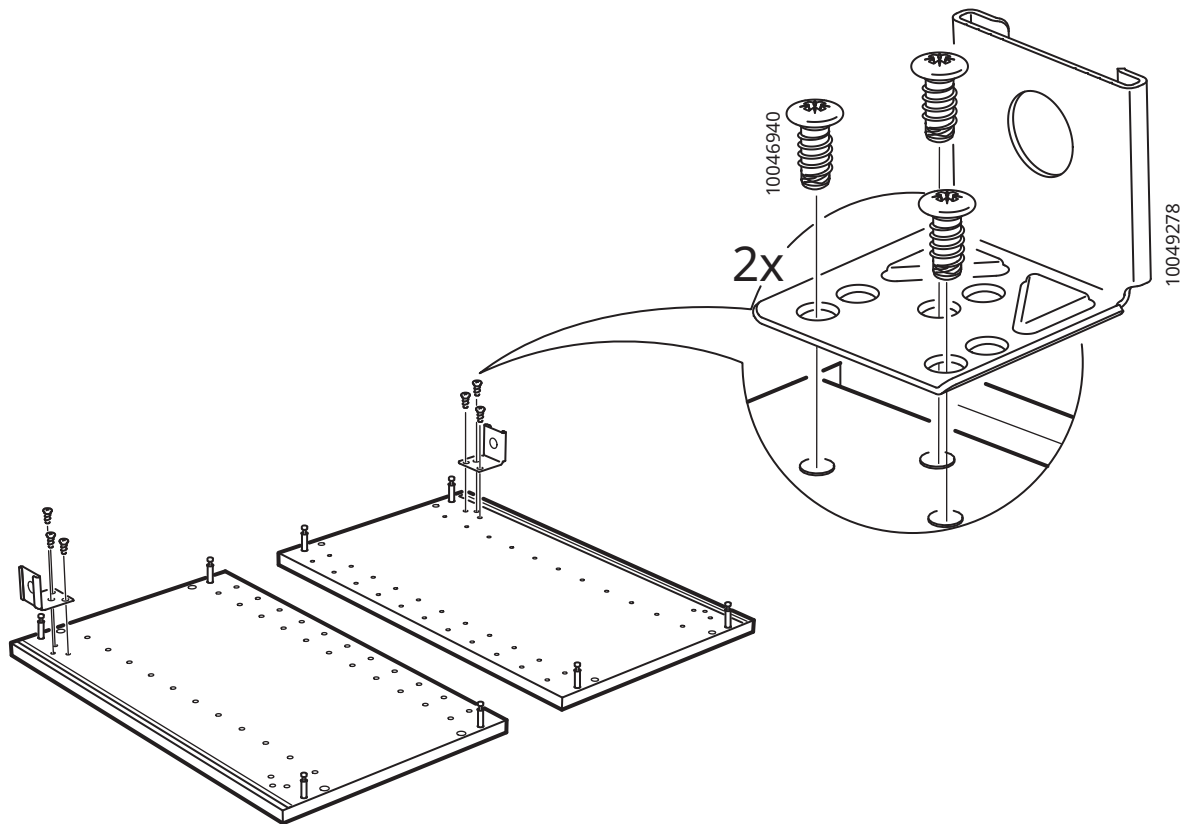



3

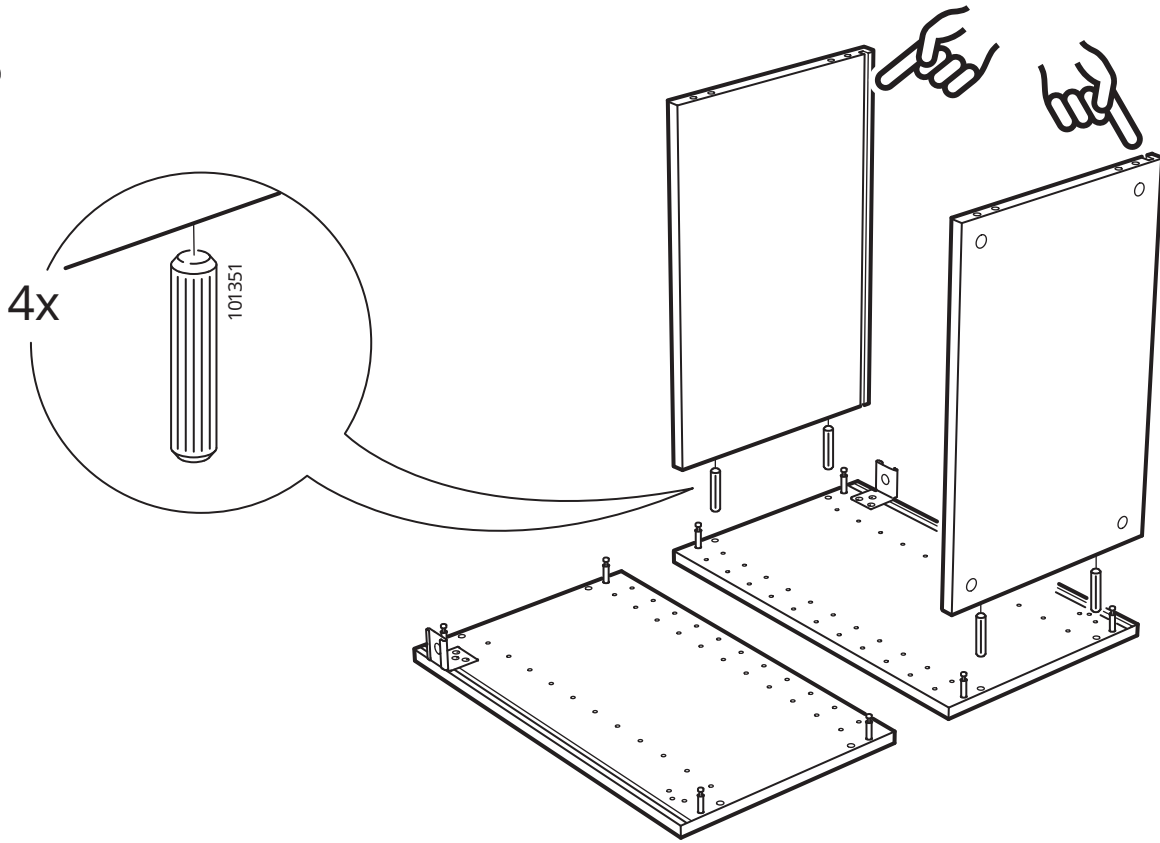

4

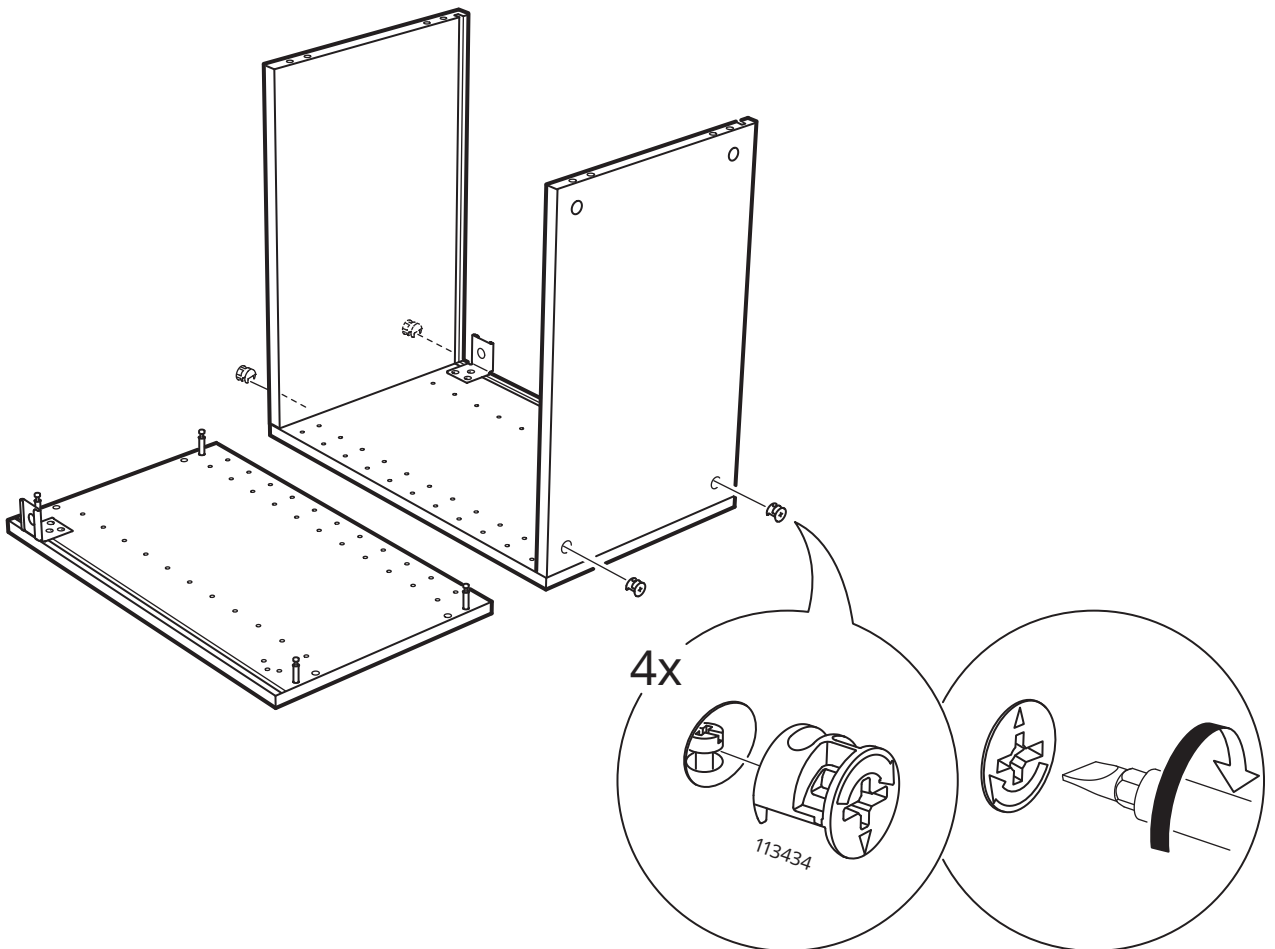

5

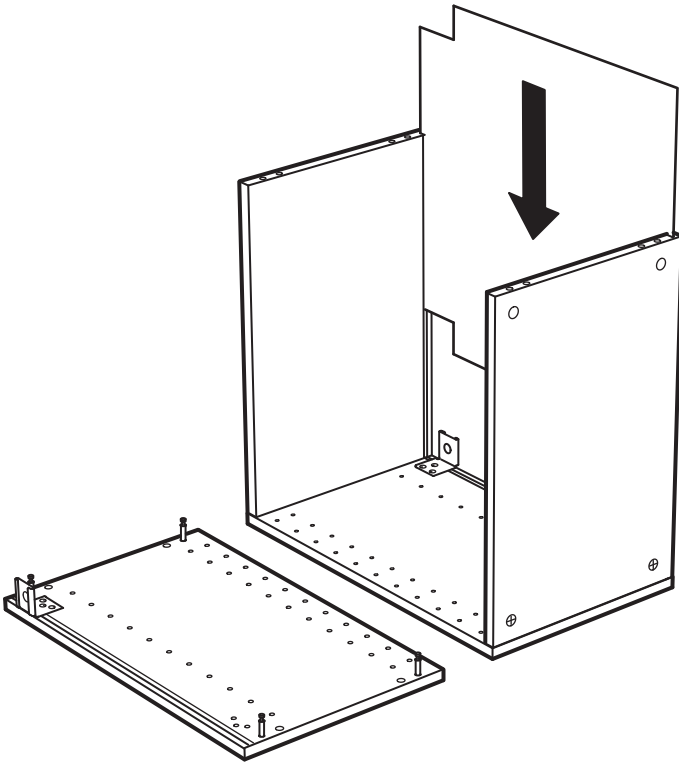

6

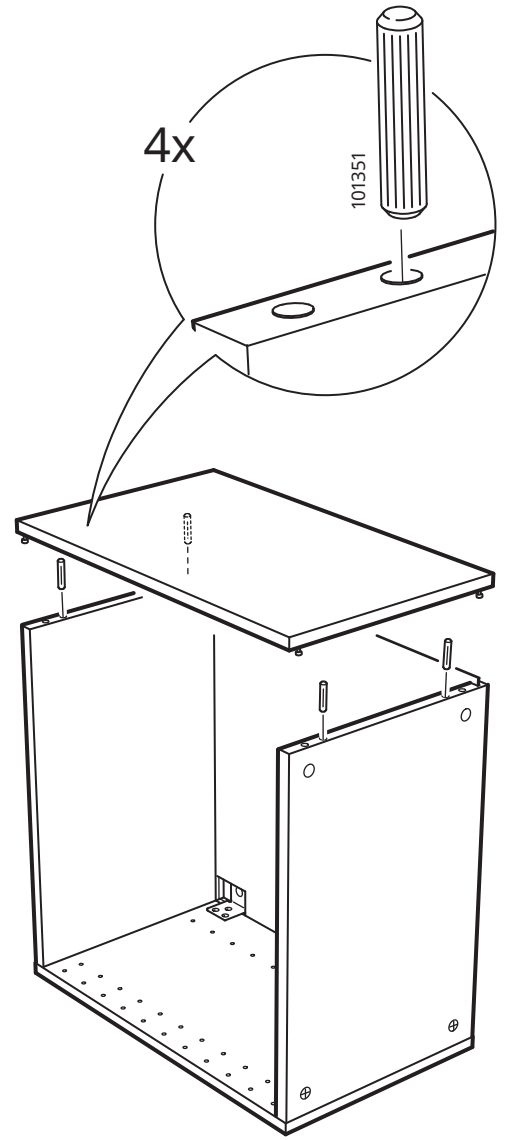

7

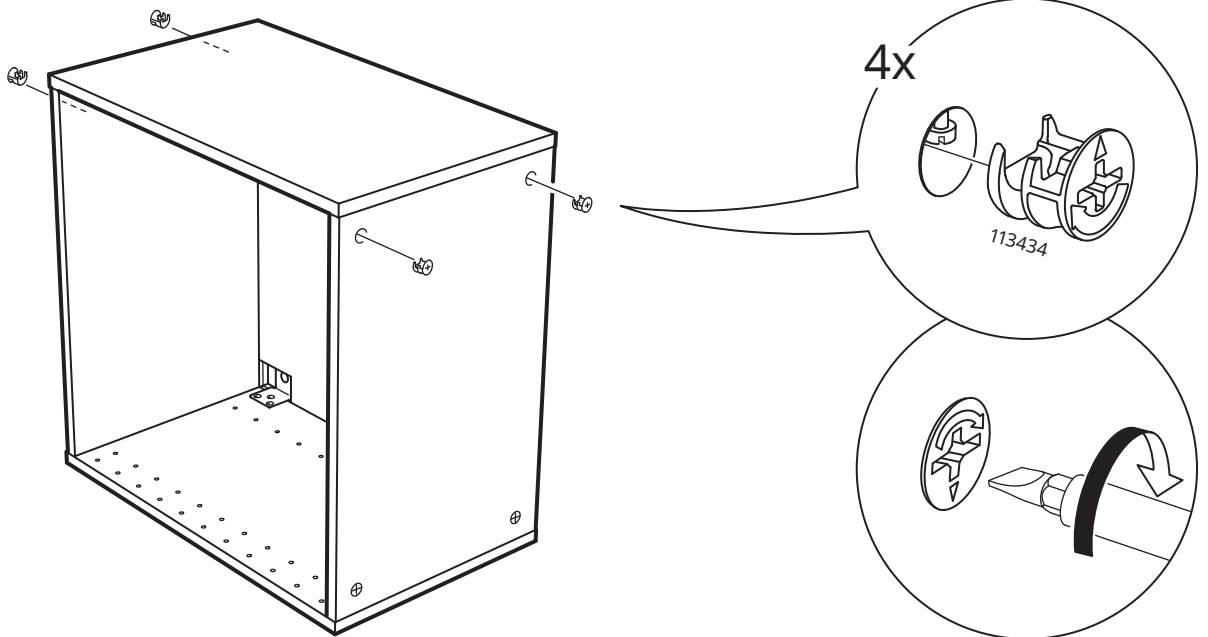

8

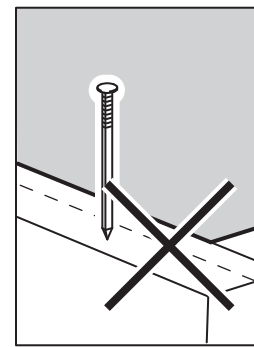
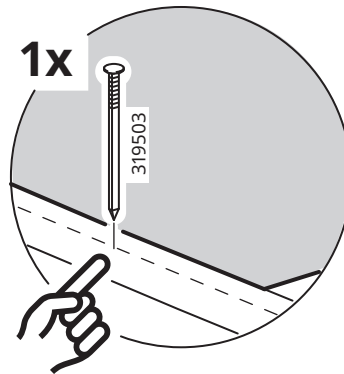
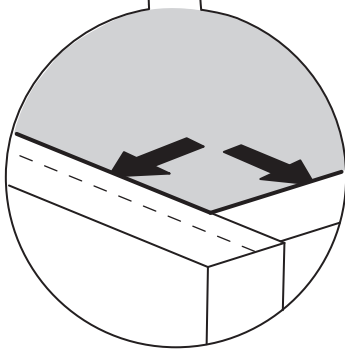
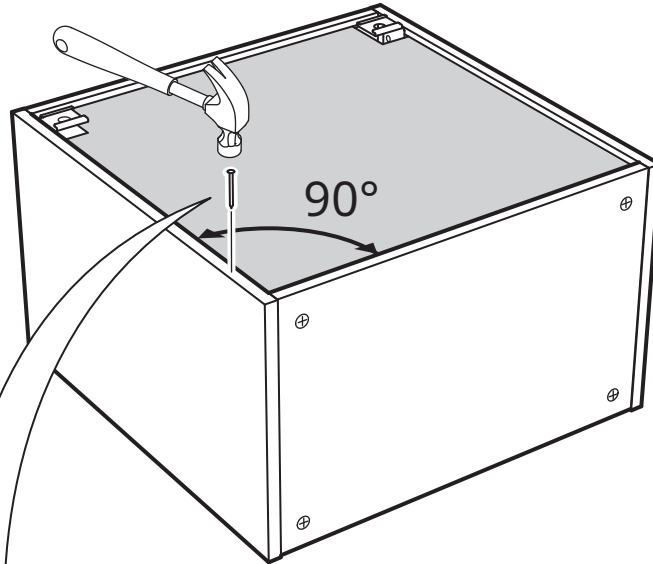
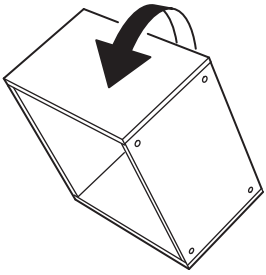
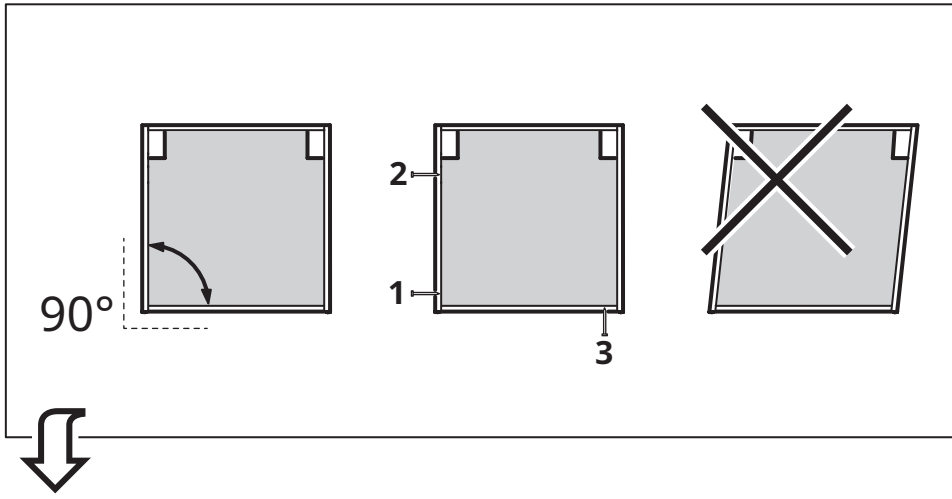

9

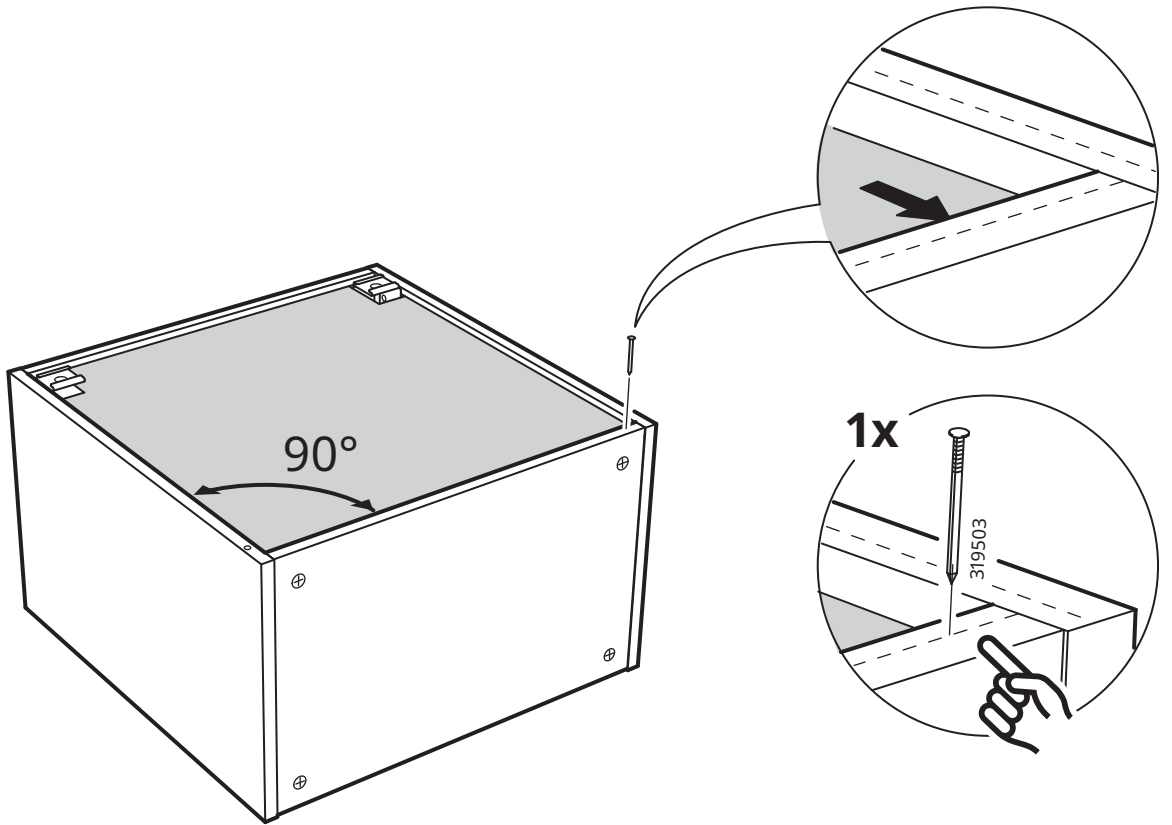

10

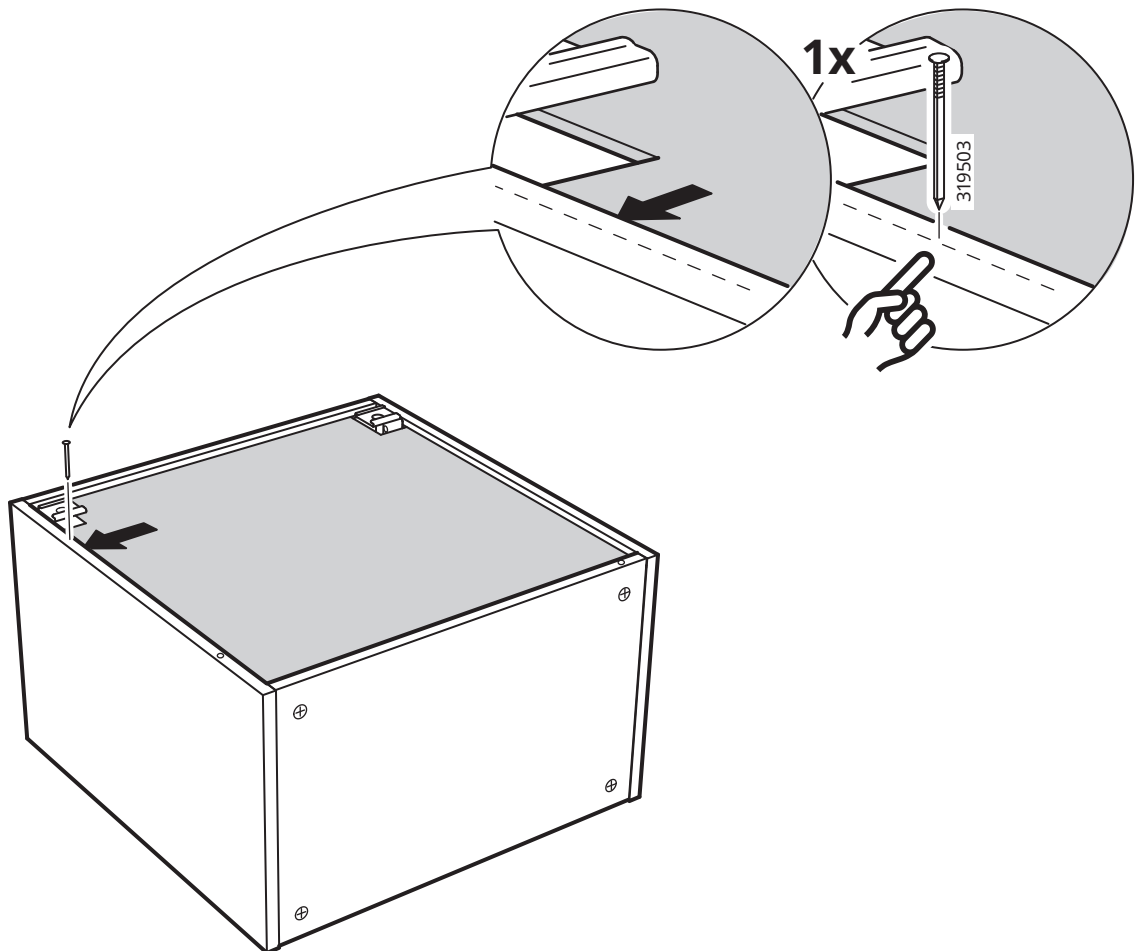

# 11

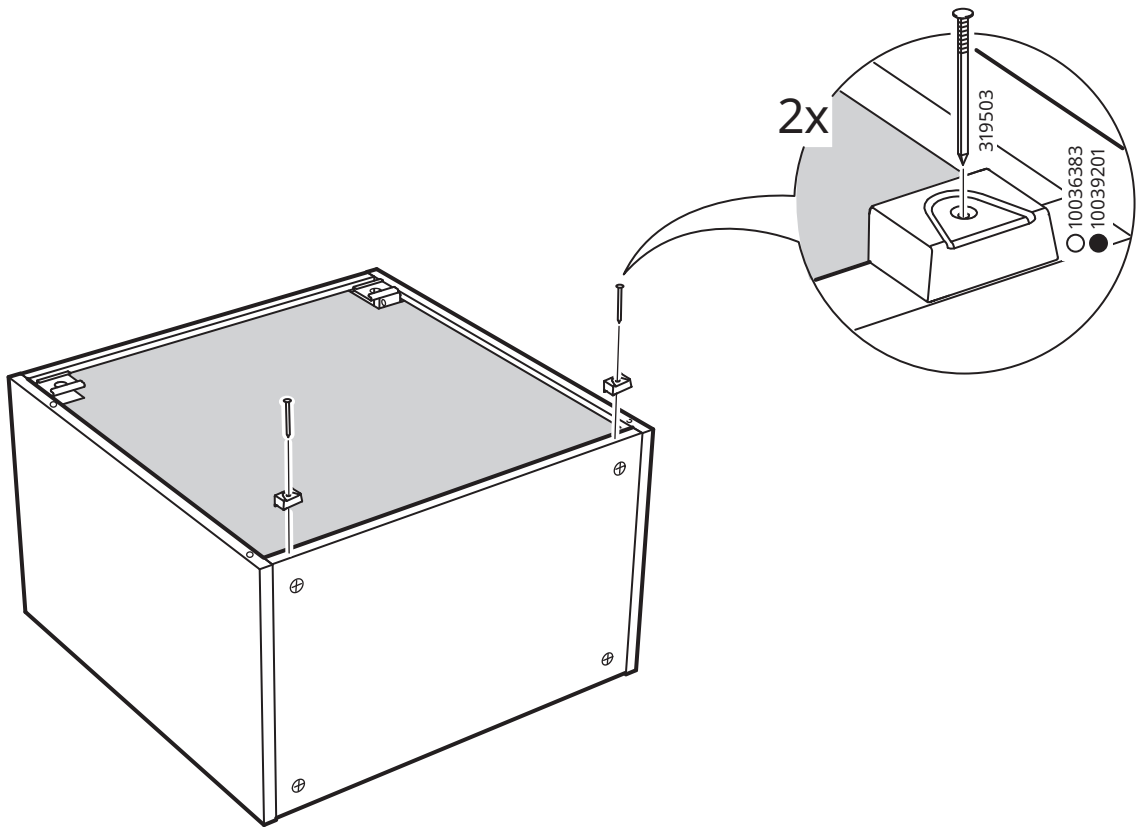

# 12

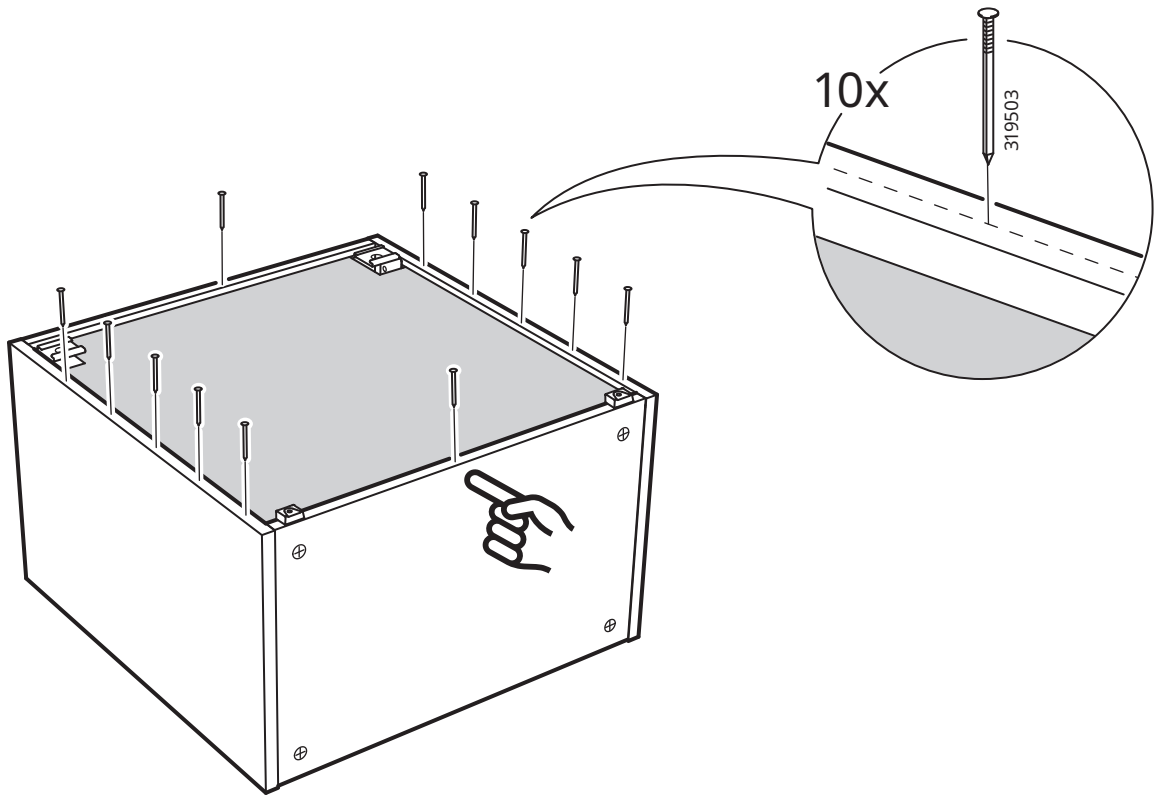

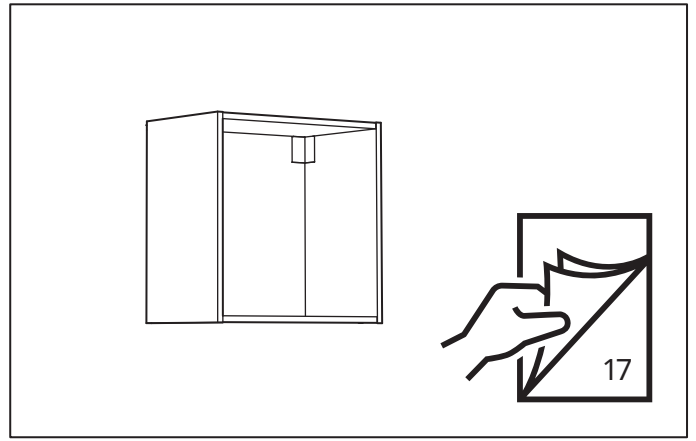
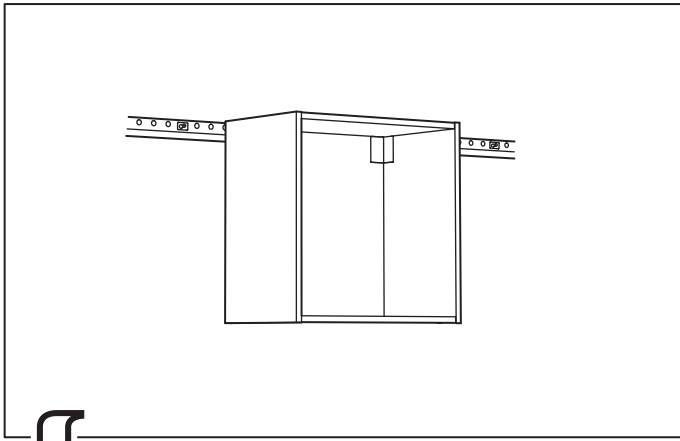

13

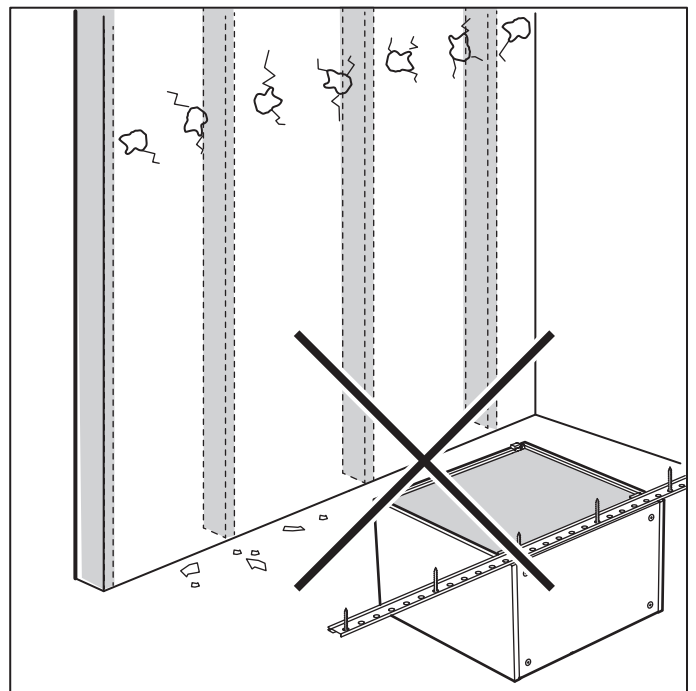
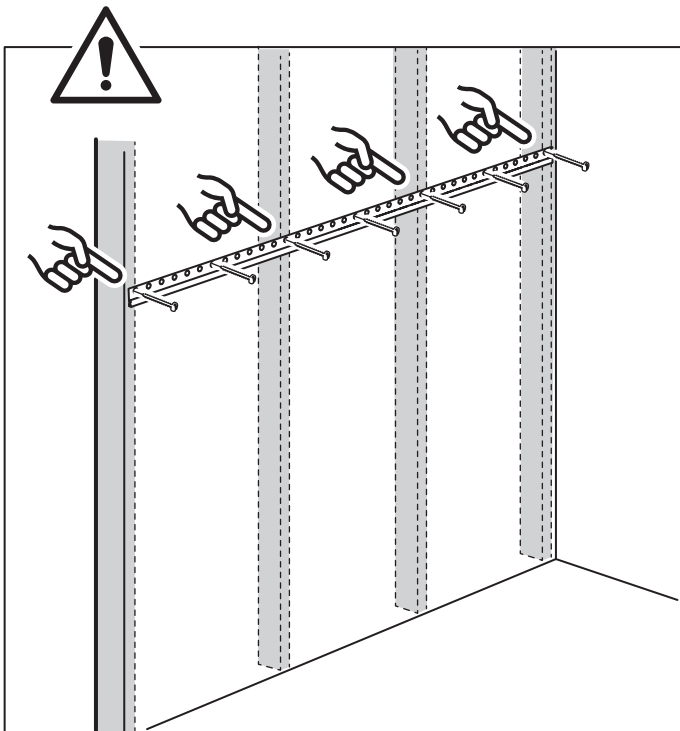
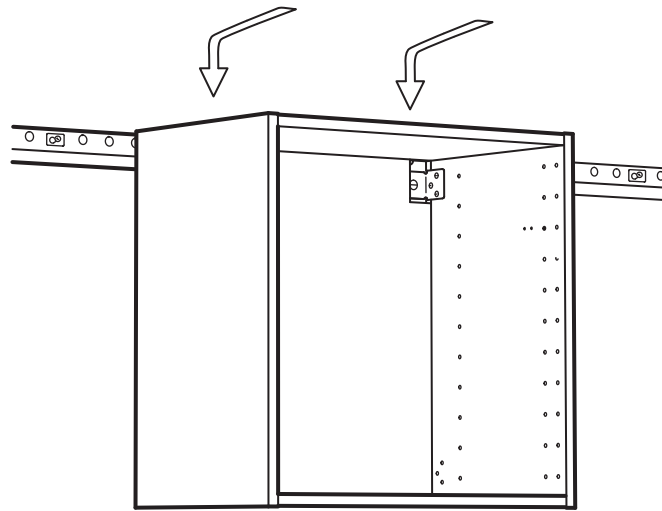
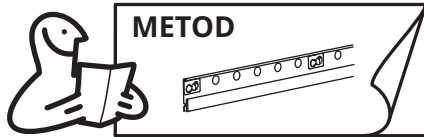

# 14

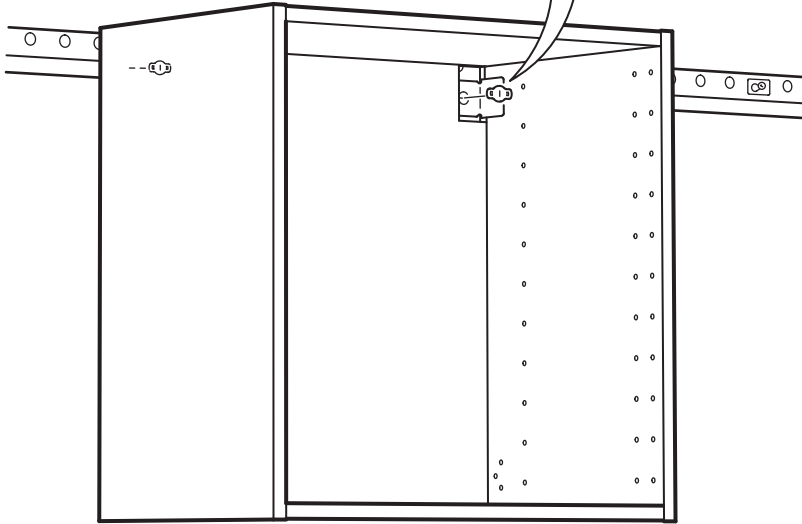
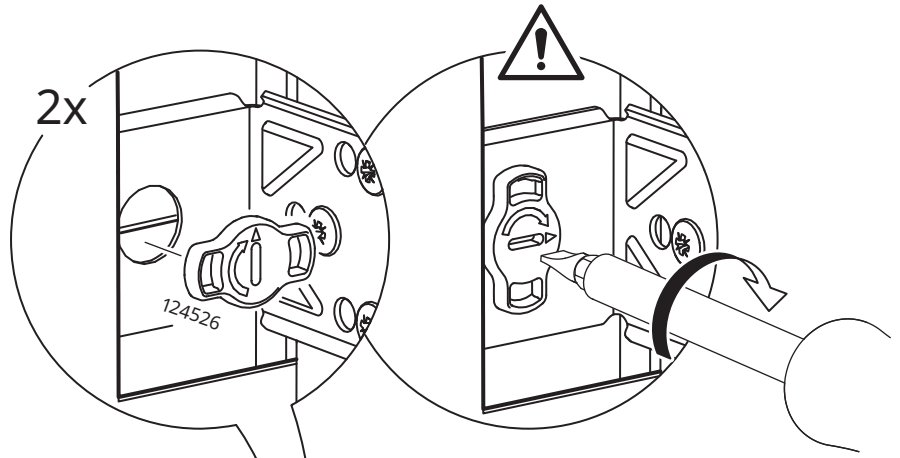
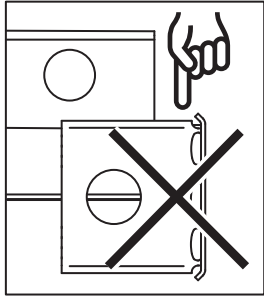
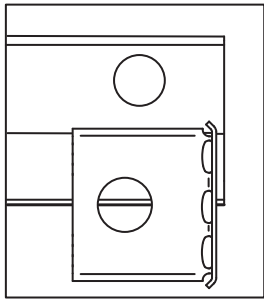

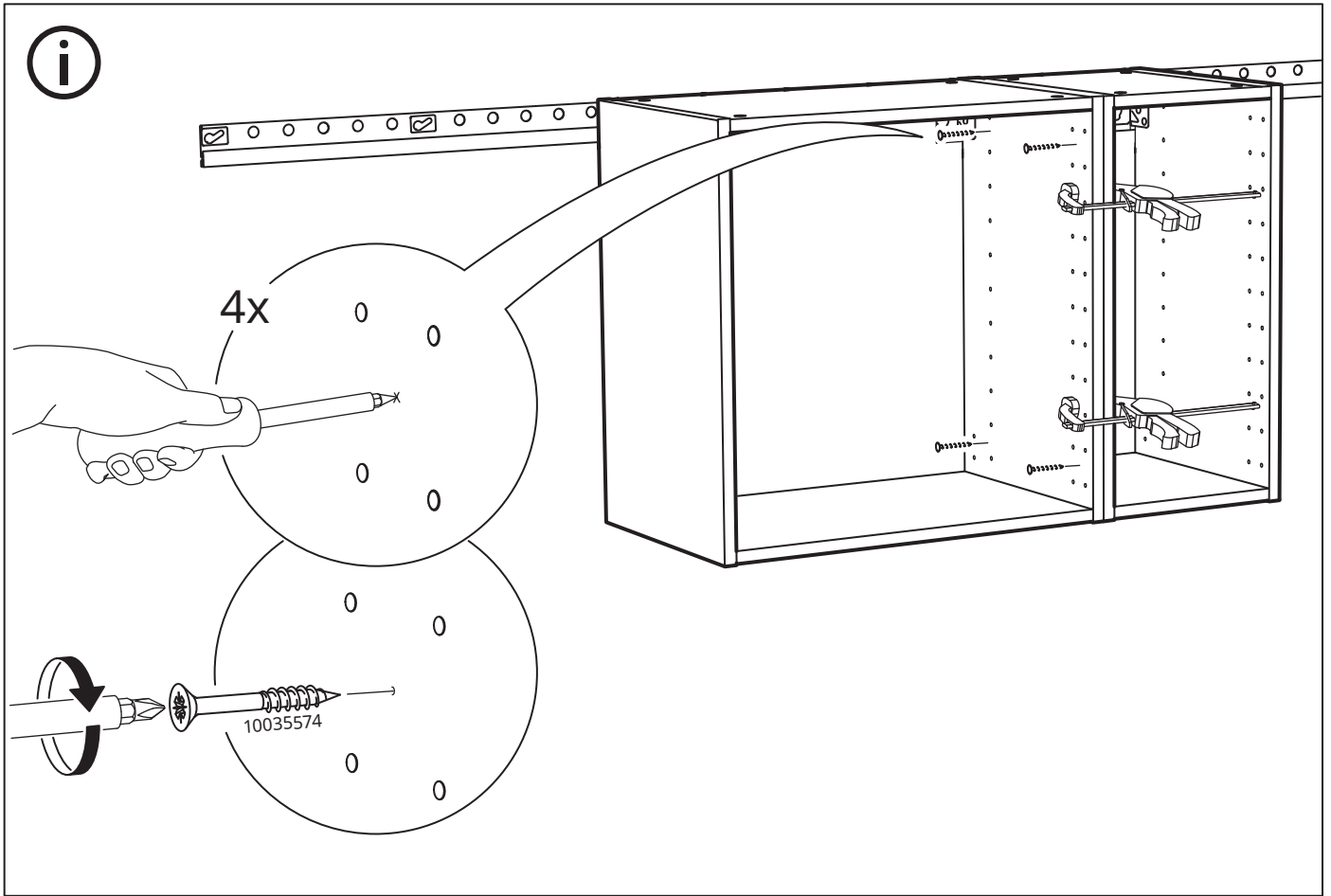

# 15

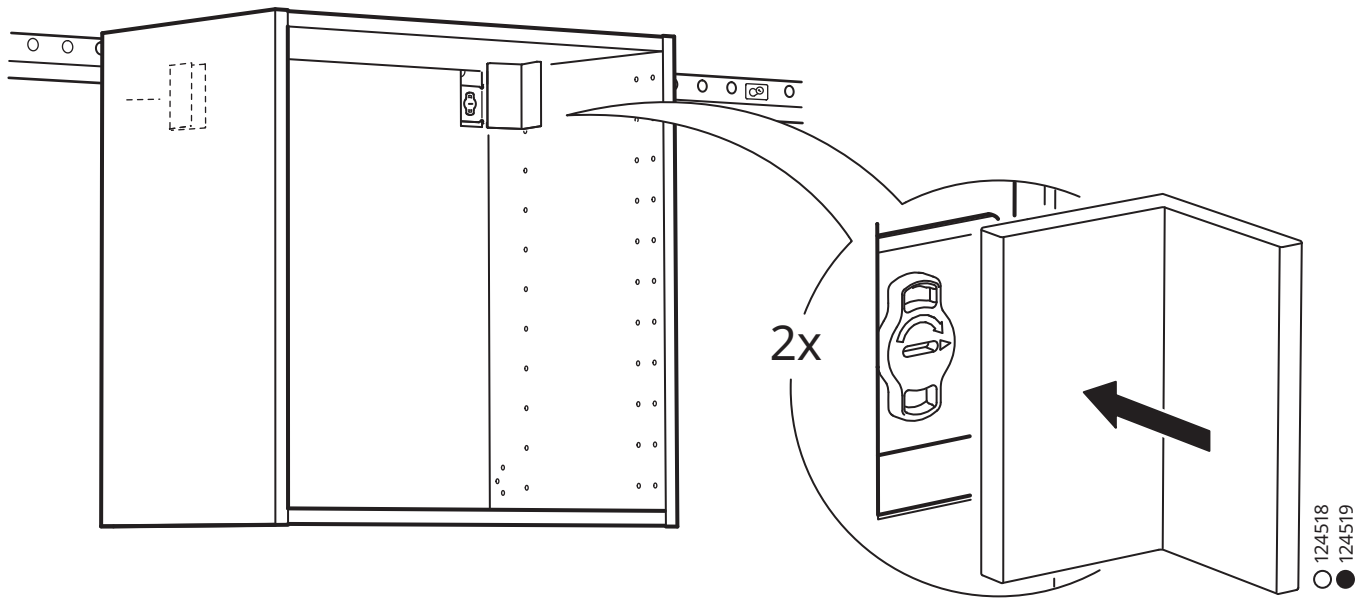



13

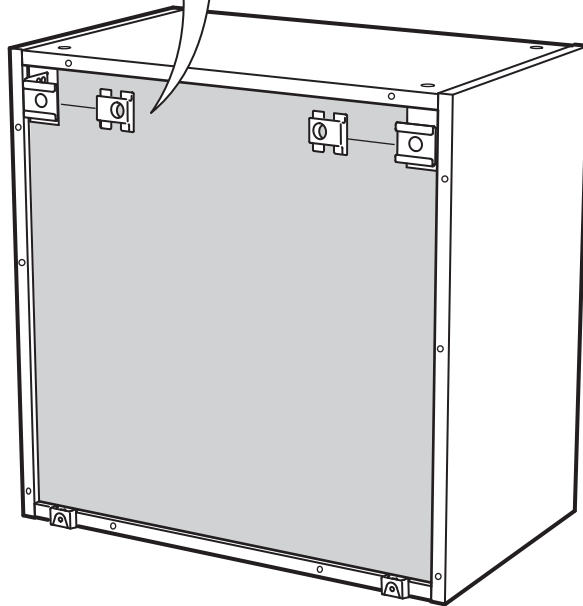
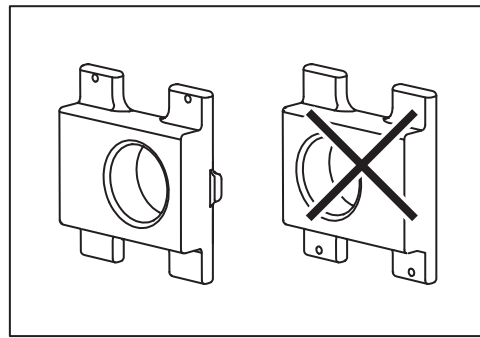
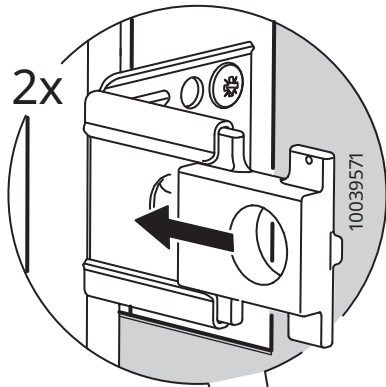
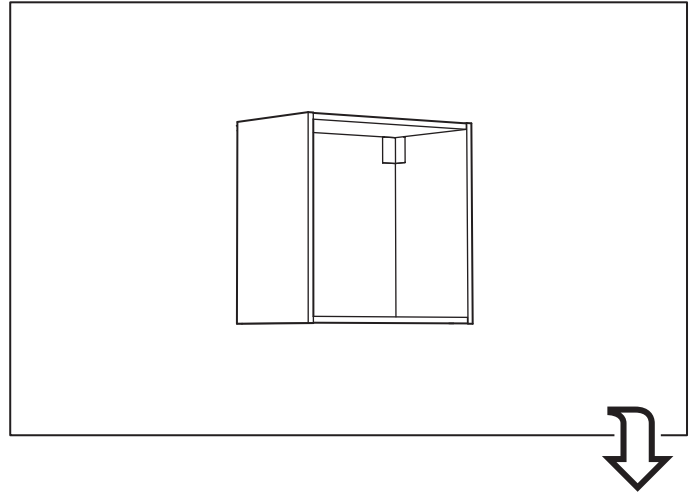

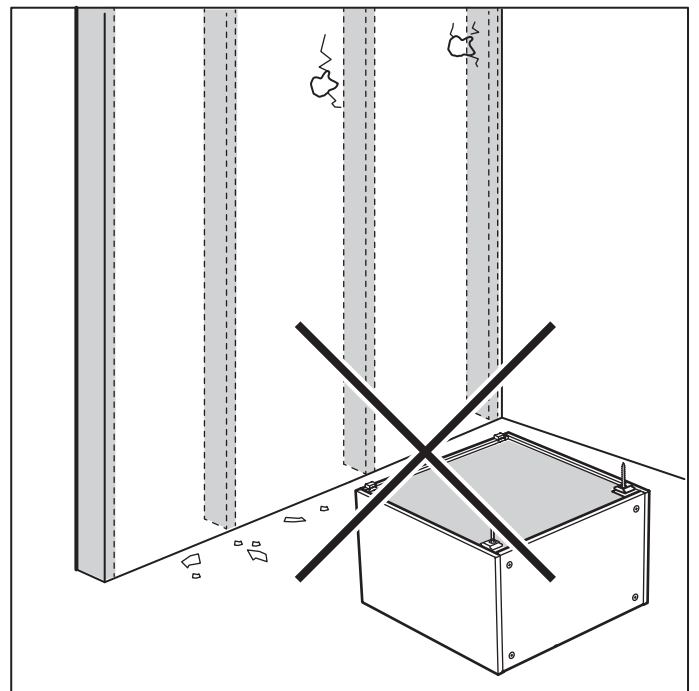
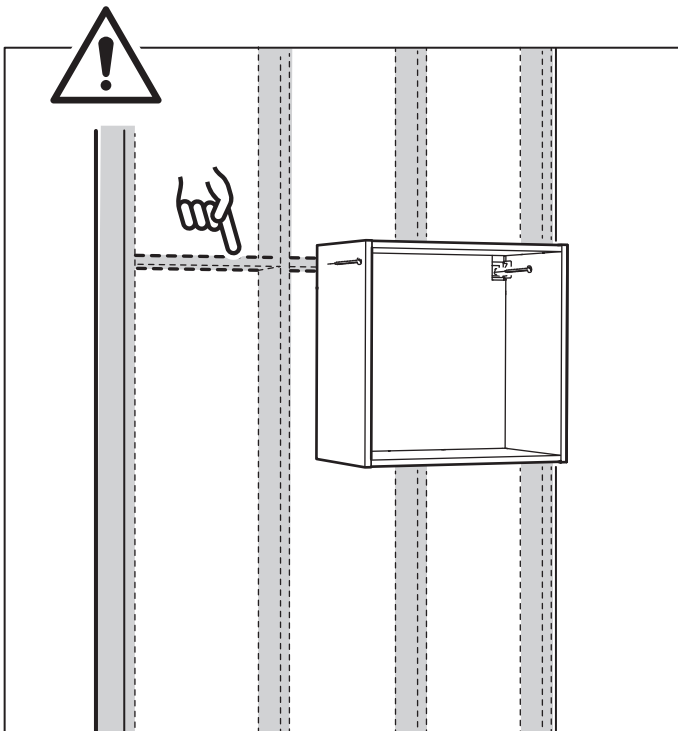
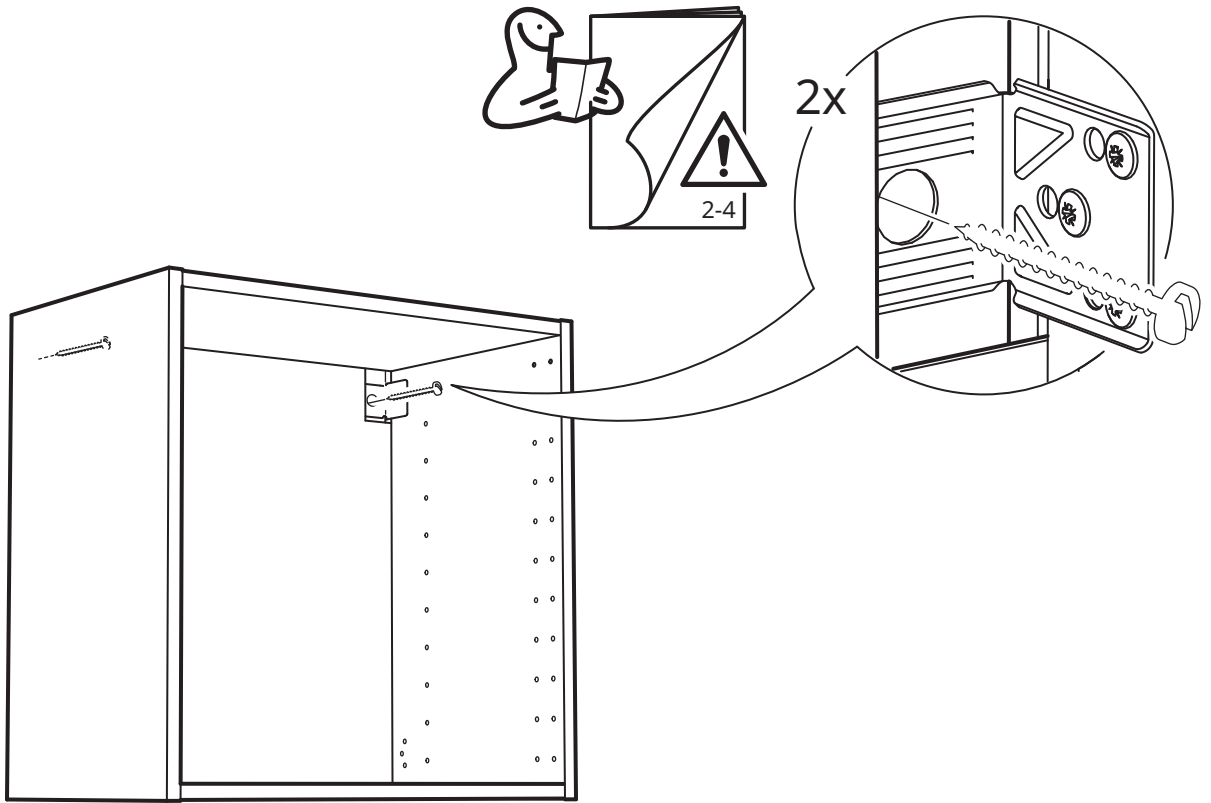
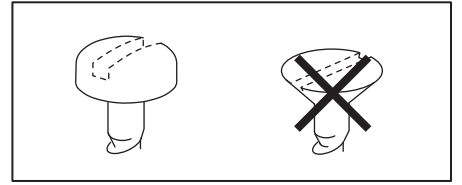

# 15

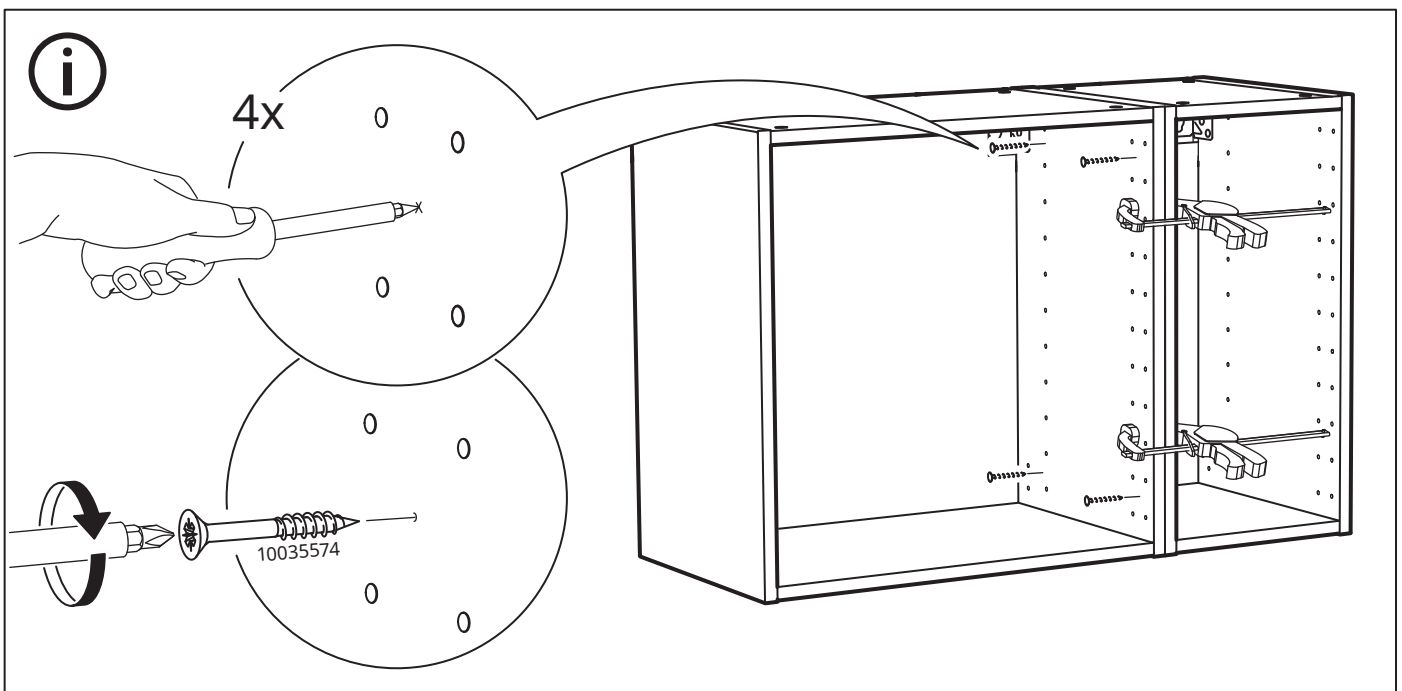
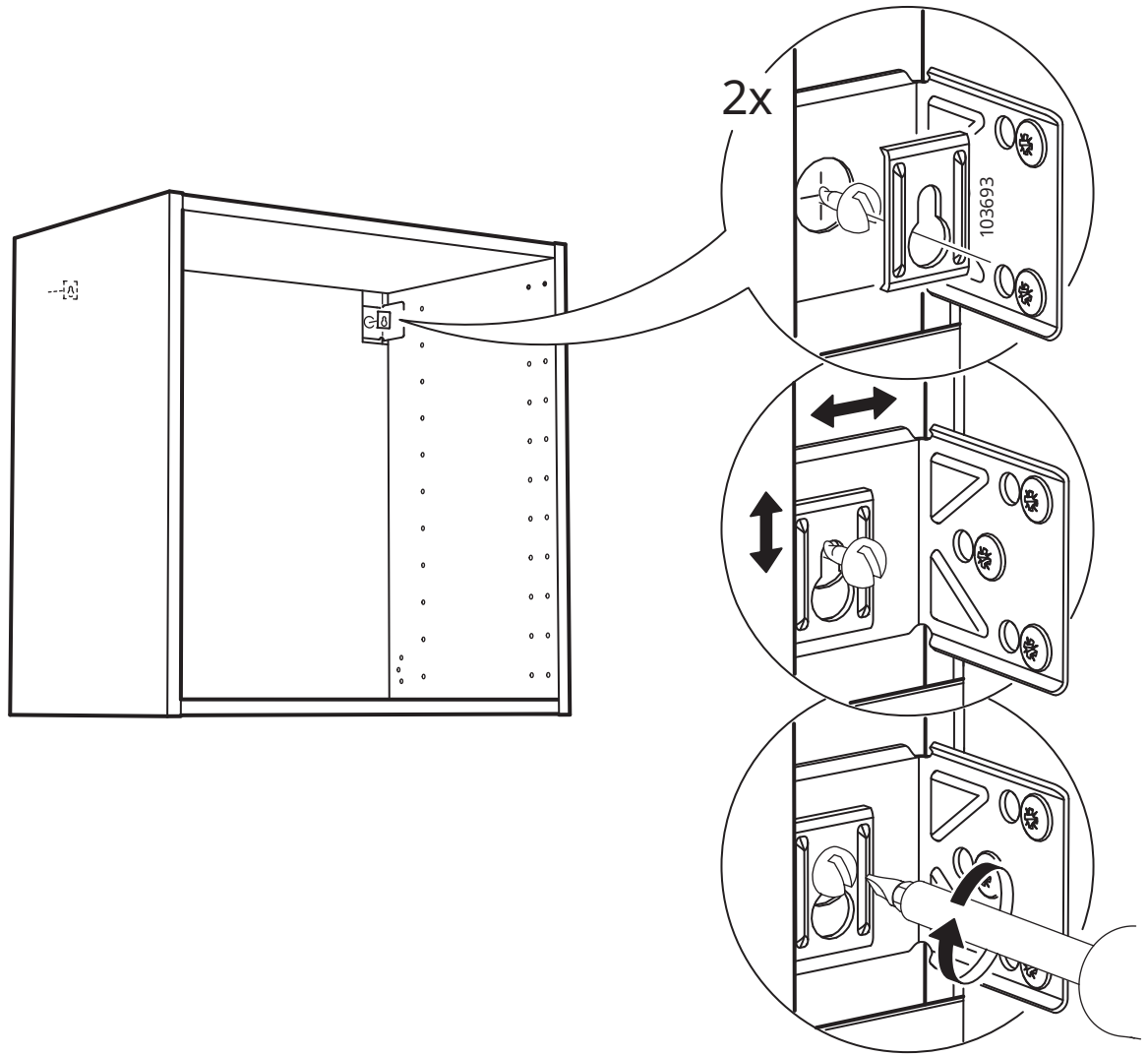

# 16

