

RÅDMANSÖ

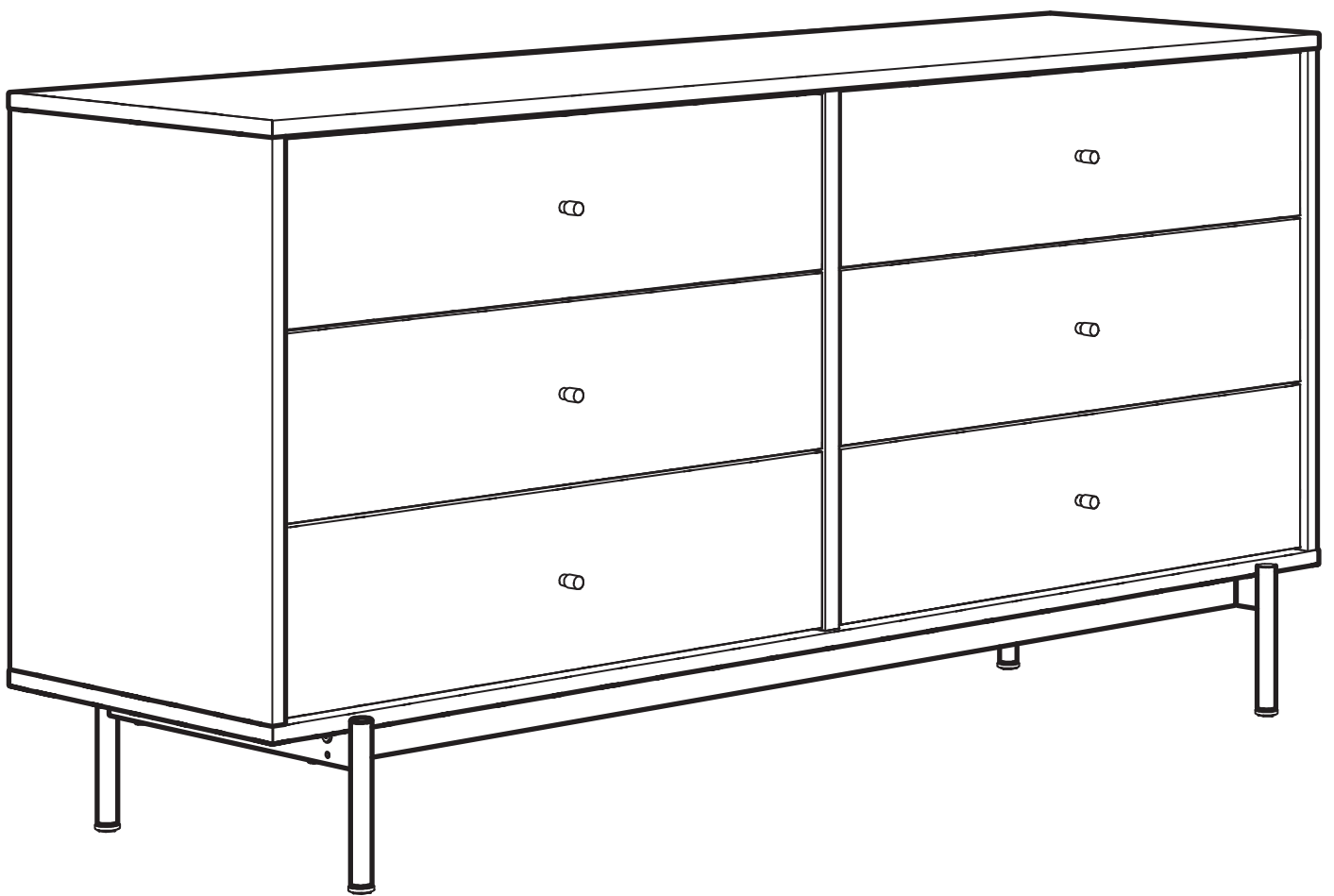

Design and Quality
IKEA of Sweden

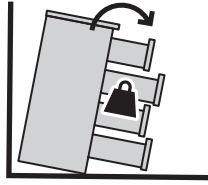
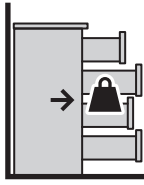

Español

ADVERTENCIA:

Si el mueble volcase, podría provocar lesiones graves e incluso mortales. Para limitar el riesgo de vuelco de los muebles:

Fija SIEMPRE el mueble a la pared con herrajes antivuelco.

Para reducir más el riesgo de daños graves o mortales por el vuelco del mueble:

Coloca los objetos más pesados en el cajón inferior.

No pongas la televisión u otros objetos pesados en la parte superior del mueble.

Nunca permitas que los niños trepen o se cuelguen de los cajones, baldas o puertas.

Lee y sigue cada paso de las instrucciones cuidadosamente.

Galego

ADVERTENCIA

A envorcadura dun moble pode provocar lesións moi graves e mesmo mortais. Para reducir os riscos de envorcadura:

Fixar SEMPRE este moble á parede utilizando os accesorios antienvorcadura.

Para reducir aínda máis o risco de que se produzan lesións graves ou mesmo mortais:

Colocar os obxectos máis pesados no caixón inferior.

Non colocar un televisor nin ningún outro obxecto pesado enriba deste produto.

Evitar que as crianzas suban enriba do moble ou se colguen dos caixóns, portas ou estantes.

Ler e seguir atentamente as instrucións.

Català

ATENCIÓ!

Si el moble bolca, pot provocar lesions greus o la mort. Per reduir el risc que un moble bolqui:

Colla SEMPRE el moble a la paret amb ferramentes antibolcada.

Per reduir encara més el risc de danys greus o mortals:

Posa els objectes més pesants al calaix inferior.

No posis un televisor o altres objectes pesants en la part de dalt del moble.

No deixis que els infants s'enfilin o es pengin dels calaixos, les lleixes o les portes.

Llegeix i segueix atentament els passos de les instruccions.

Euskara

KONTUZ!

Altzaria iraultzen bada, lesio oso larriak edo heriotza izan daitezke ondorioak.

Altzarien iraultketa-arriskua mugatzeko:

Finkatu BETI altzariak horman ez iraultzeko burdinkien bidez.

Altzaria iraultzeagatik lesio larriak edo heriotza-lesioak izateko arriskua are gehiago murrizteko:

Jarri gehien pisatzen duten objektuak beheko tiraderan.

Ez jarri telebista edo bestelako objektu astunak altzariaren goiko aldean.



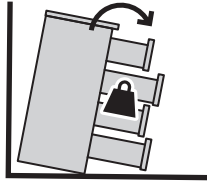
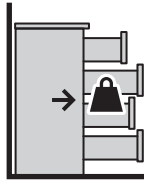

Ez utzi inoiz haurrei tiradera, ate edo apaletan gora egiten edo horietatik zintzilikatzen.

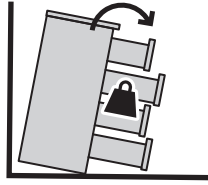
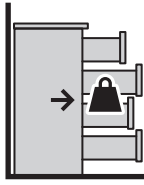
Irakurri eta jarraitu argibideetako urrats bakoitza kontu handiz.

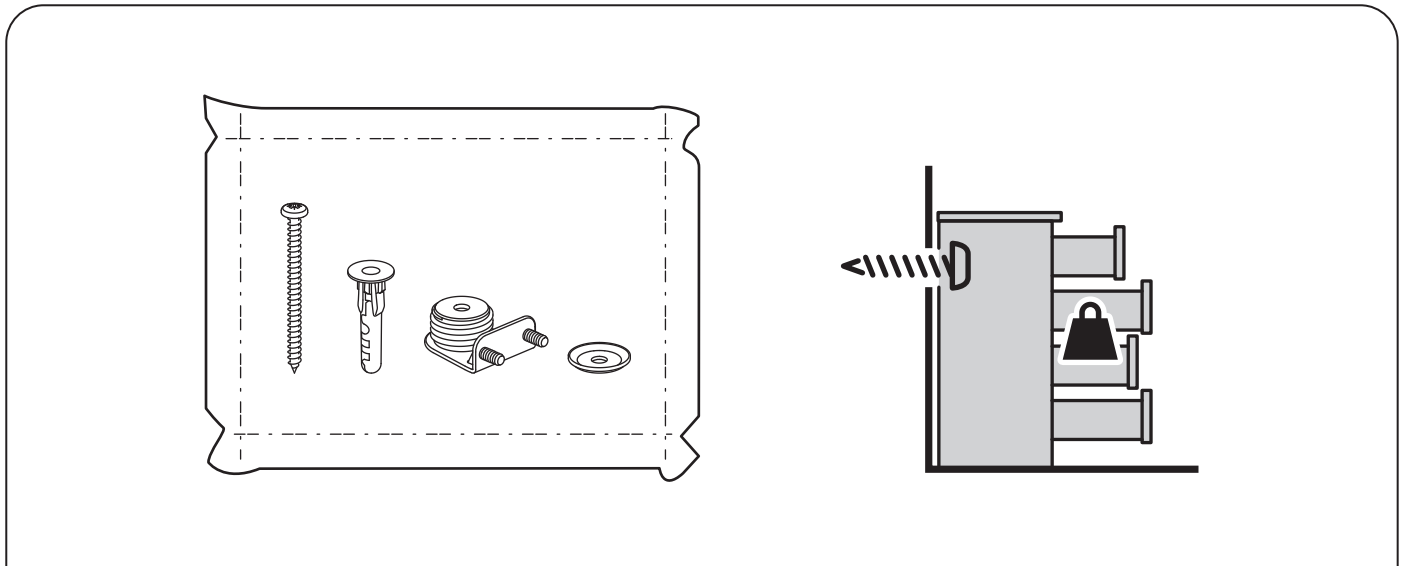
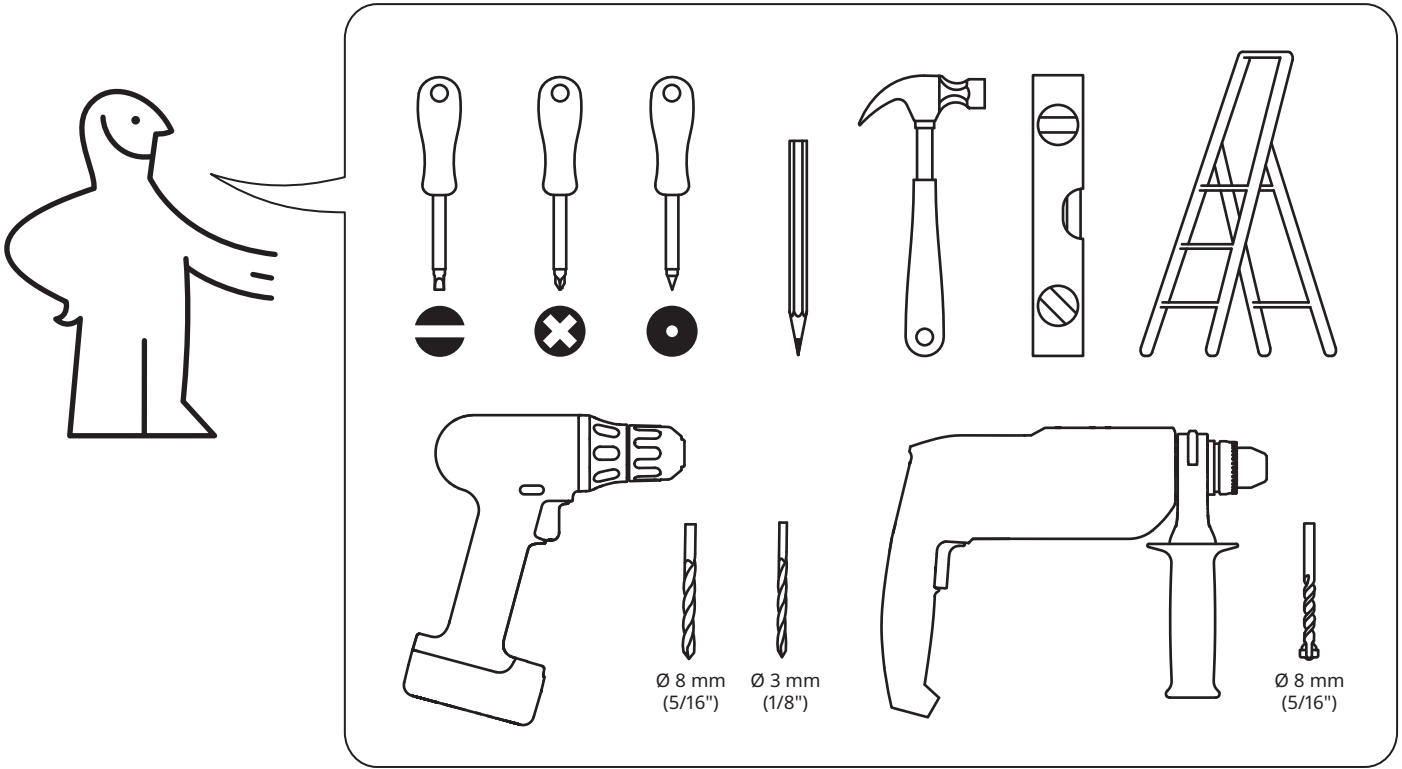

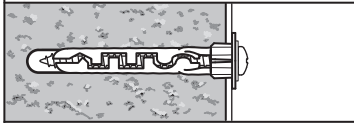
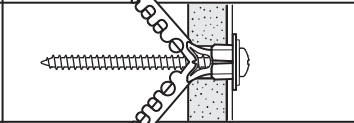
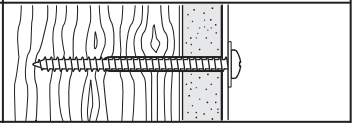



 <p>www.IKEA.com/secure-it</p>	A	B	C
			
	<p>Ø 8 mm (5/16")</p> 	<p>Ø 8 mm (5/16")</p> 	<p>Ø 3 mm (1/8")</p> 

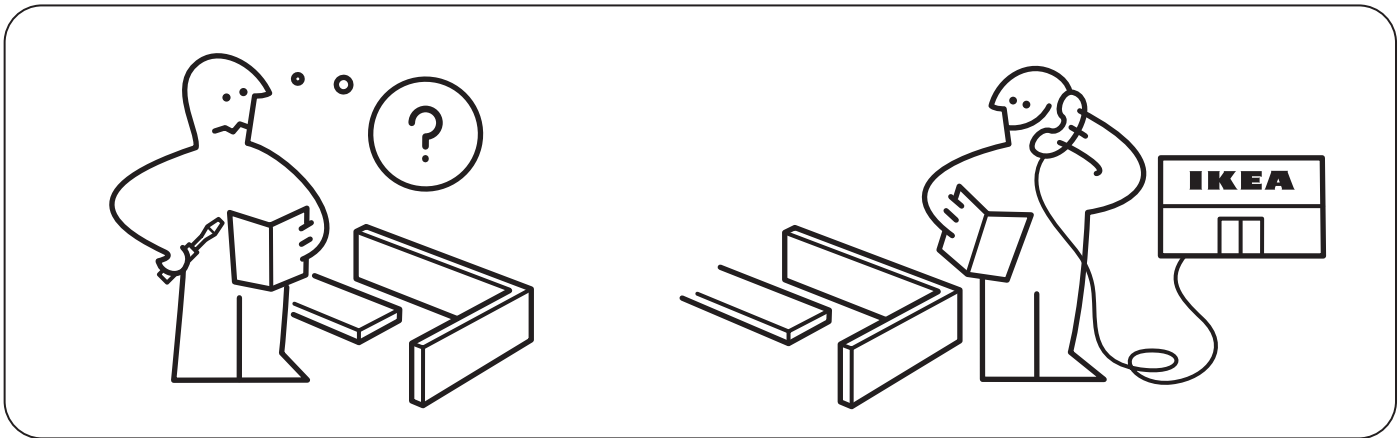
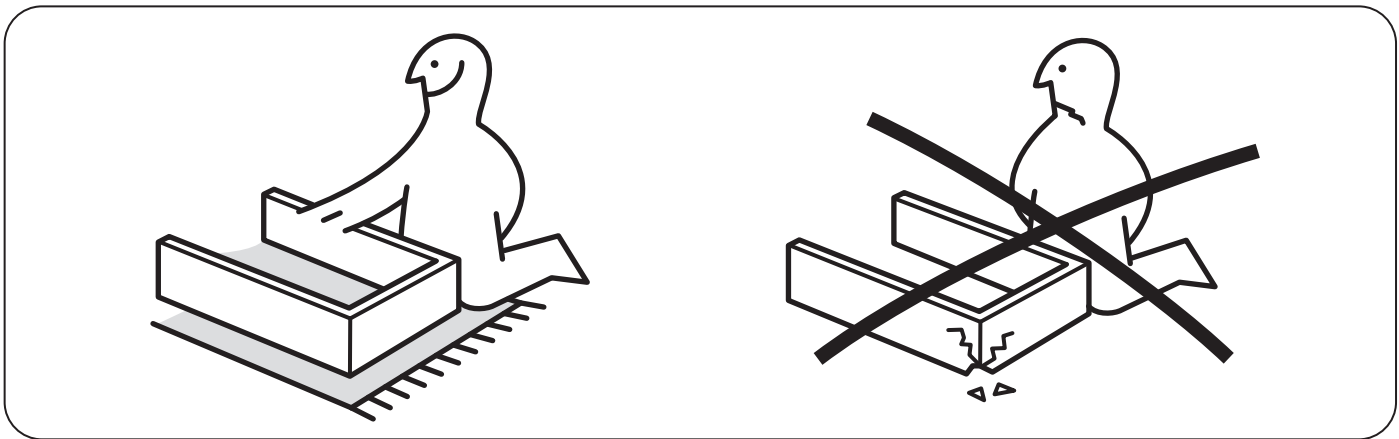
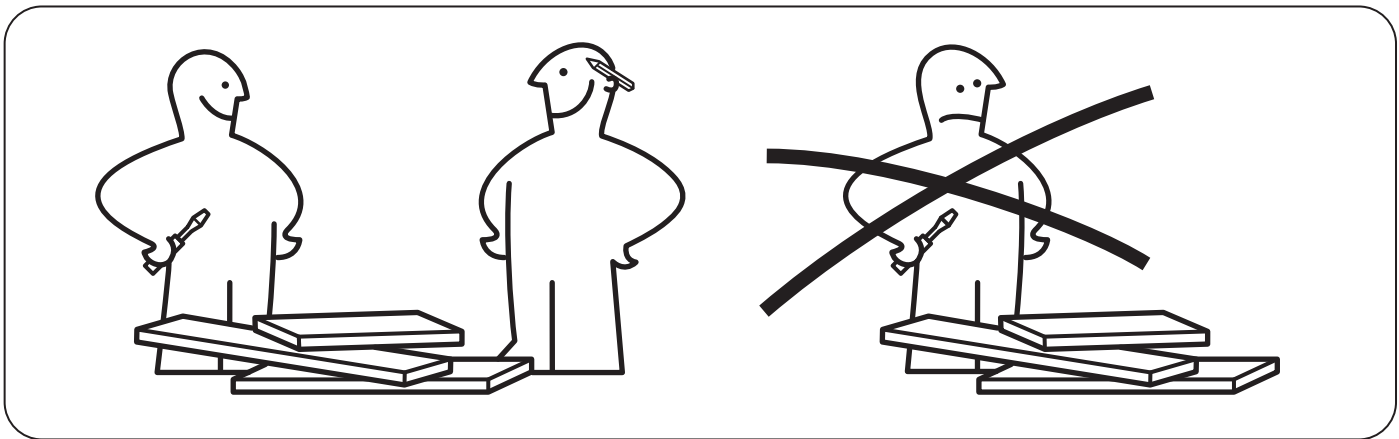

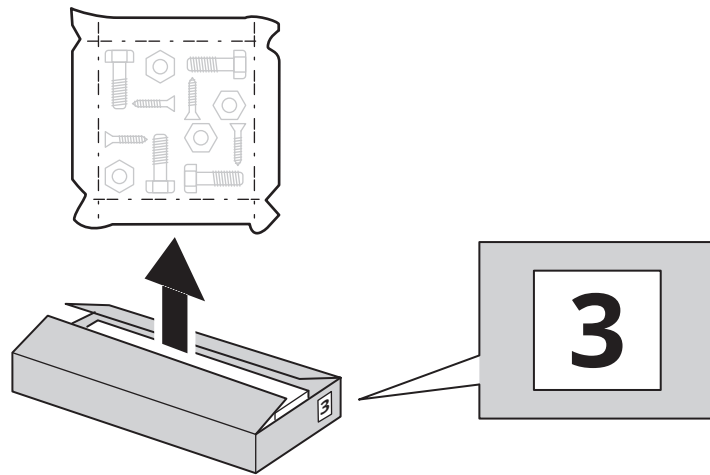

1

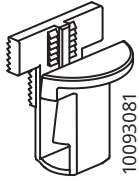

8x

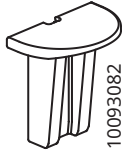

8x



6x



6x



36x

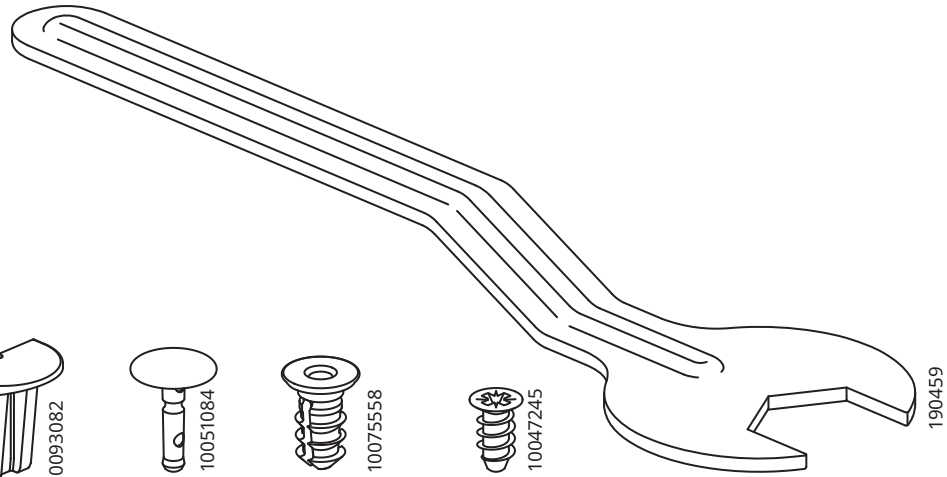

1x

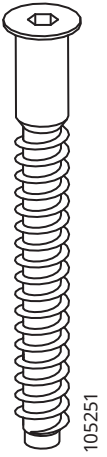

2x

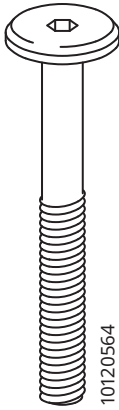

4x

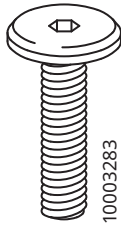

4x

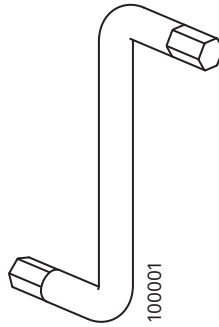

1x



4x

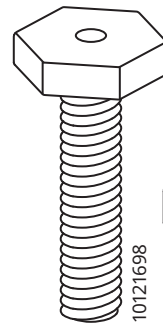

4x

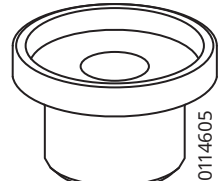

4x

2



24x

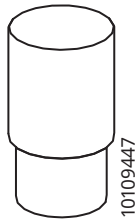

6x

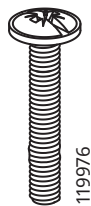

6x



24x

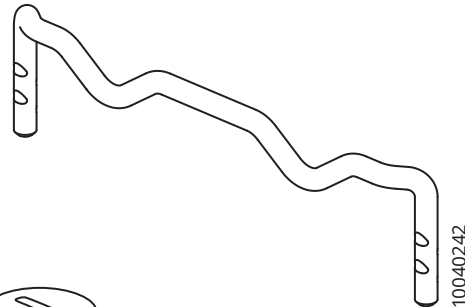

6x



36x

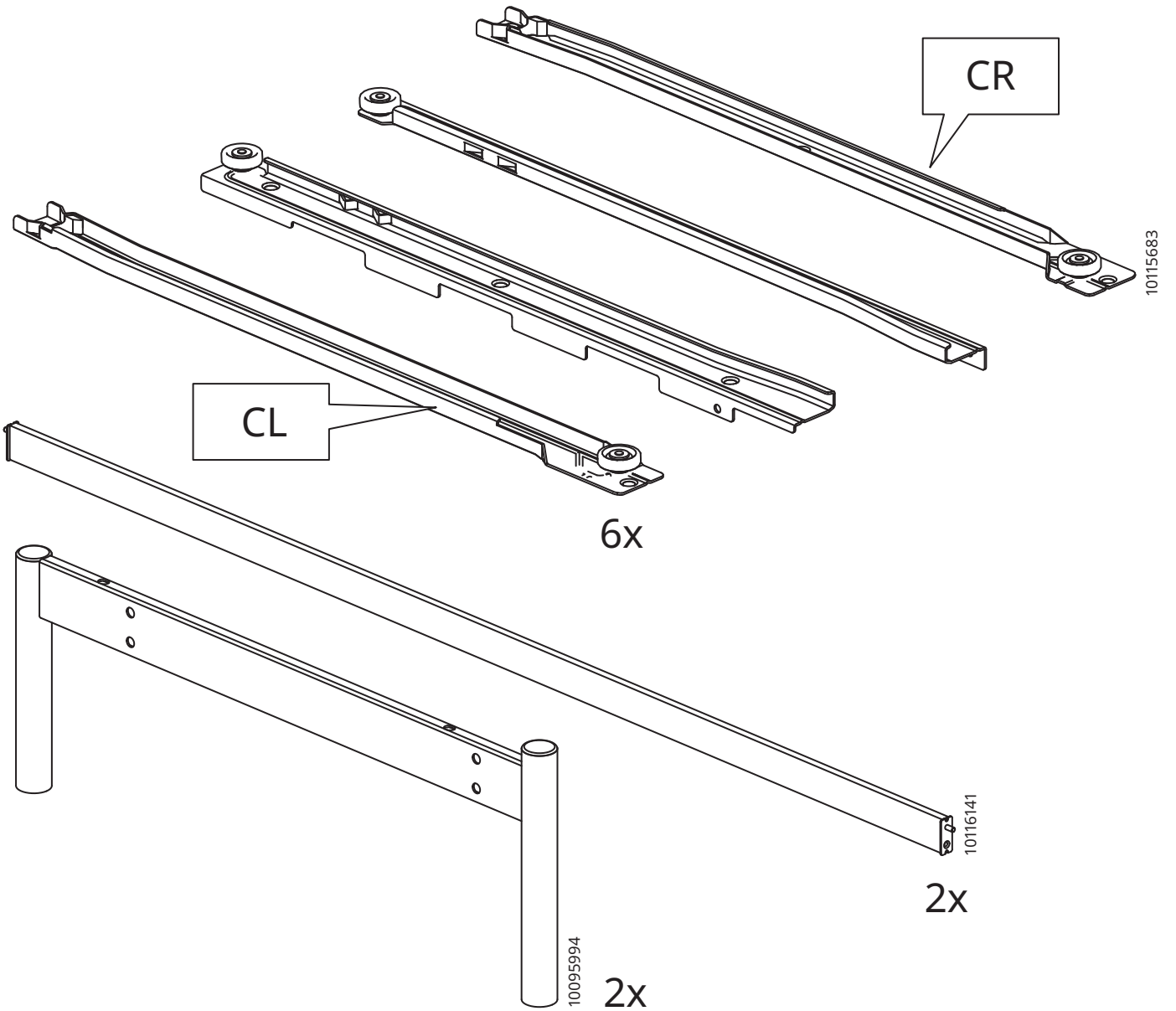
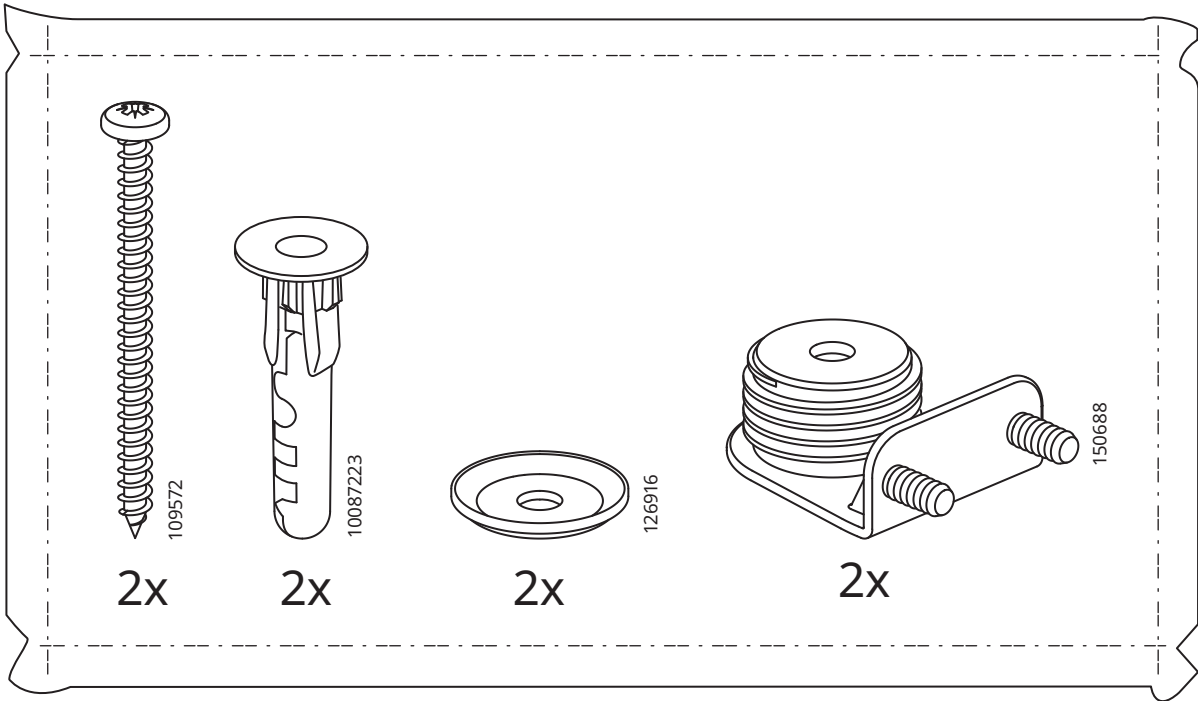

1

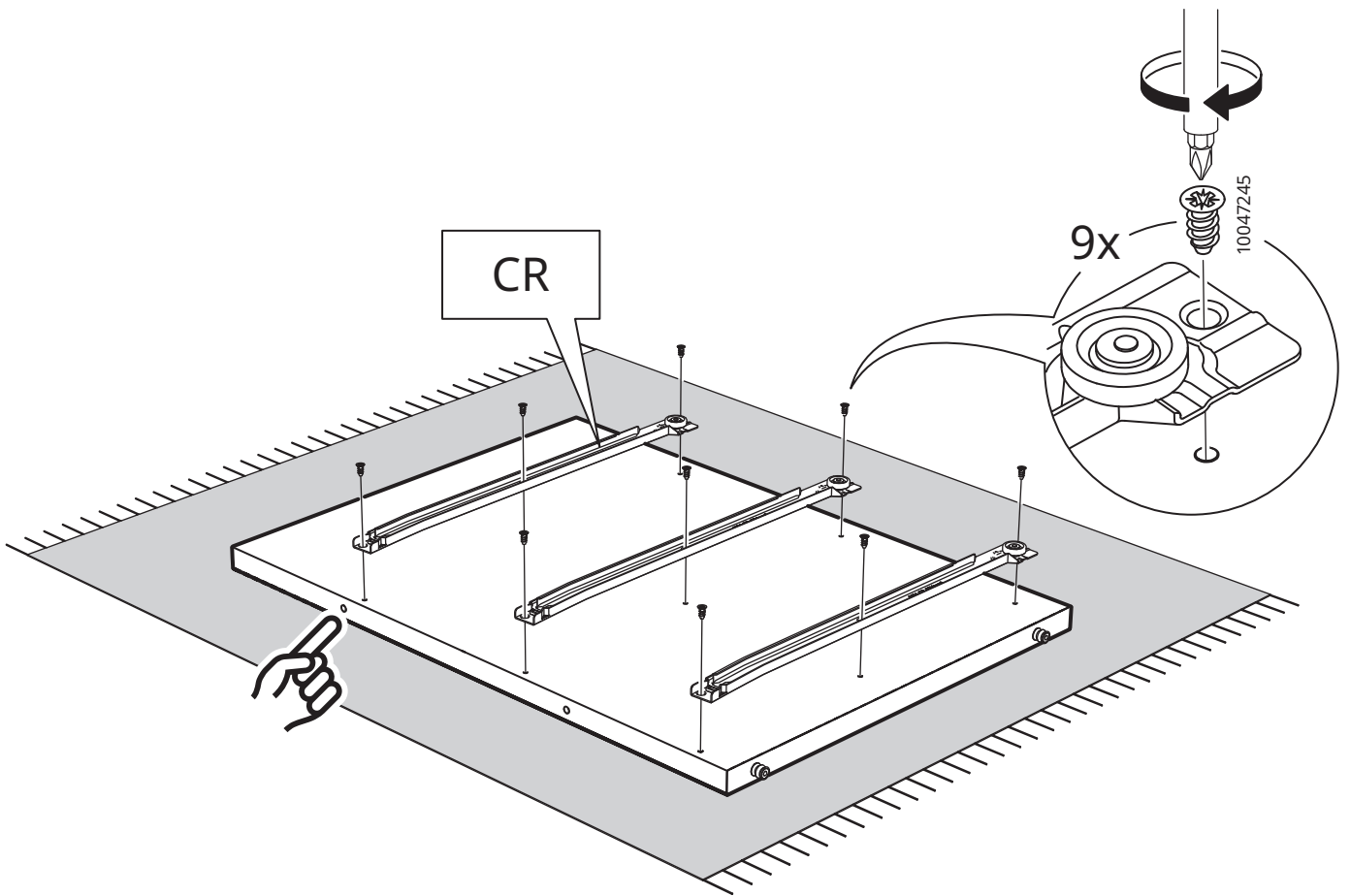

2

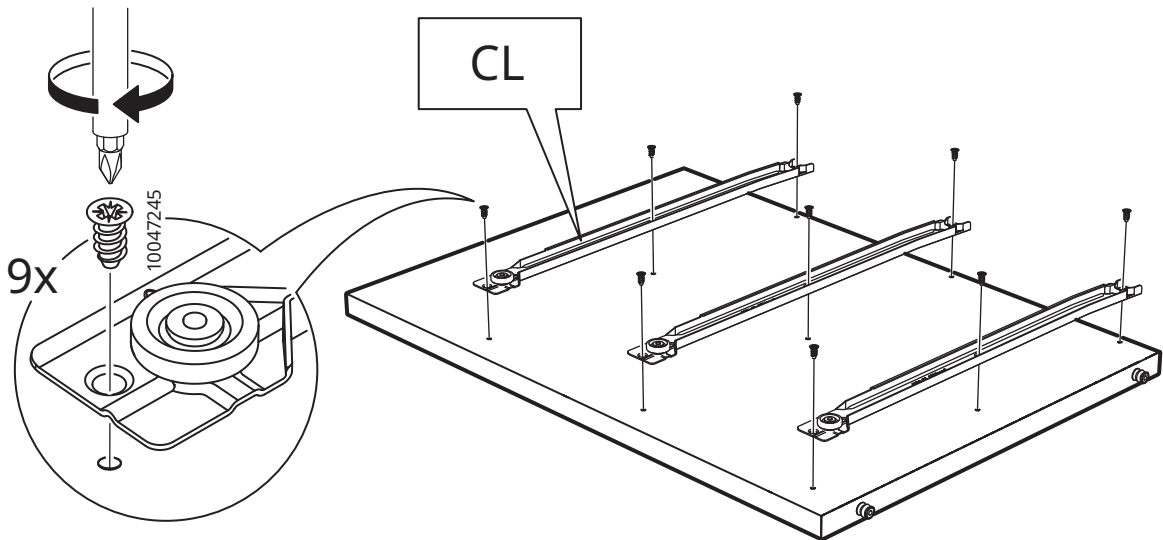
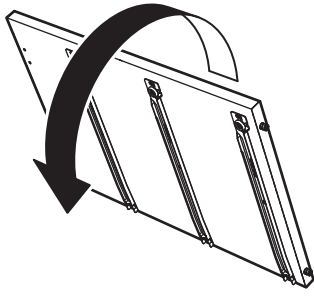

3

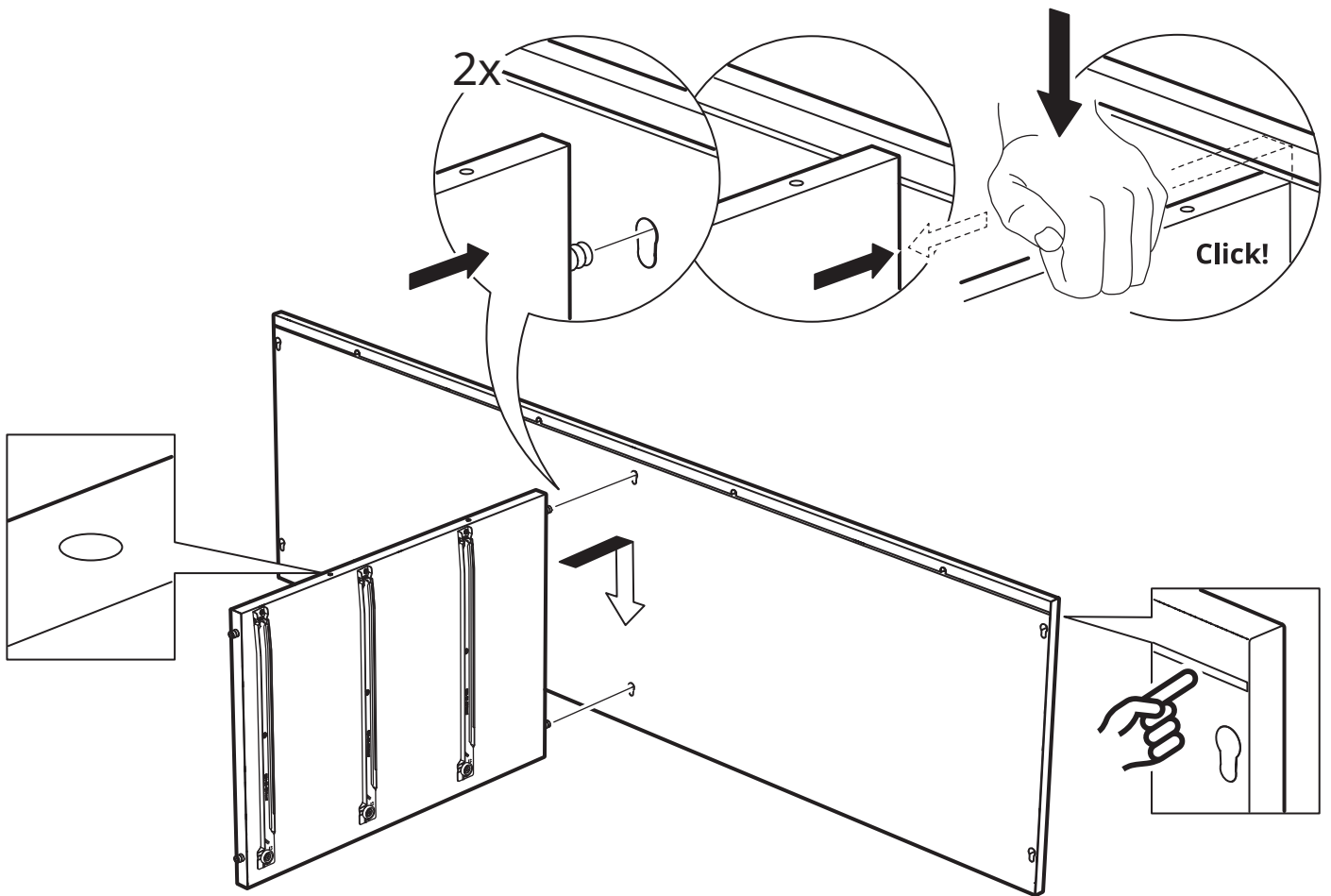

4

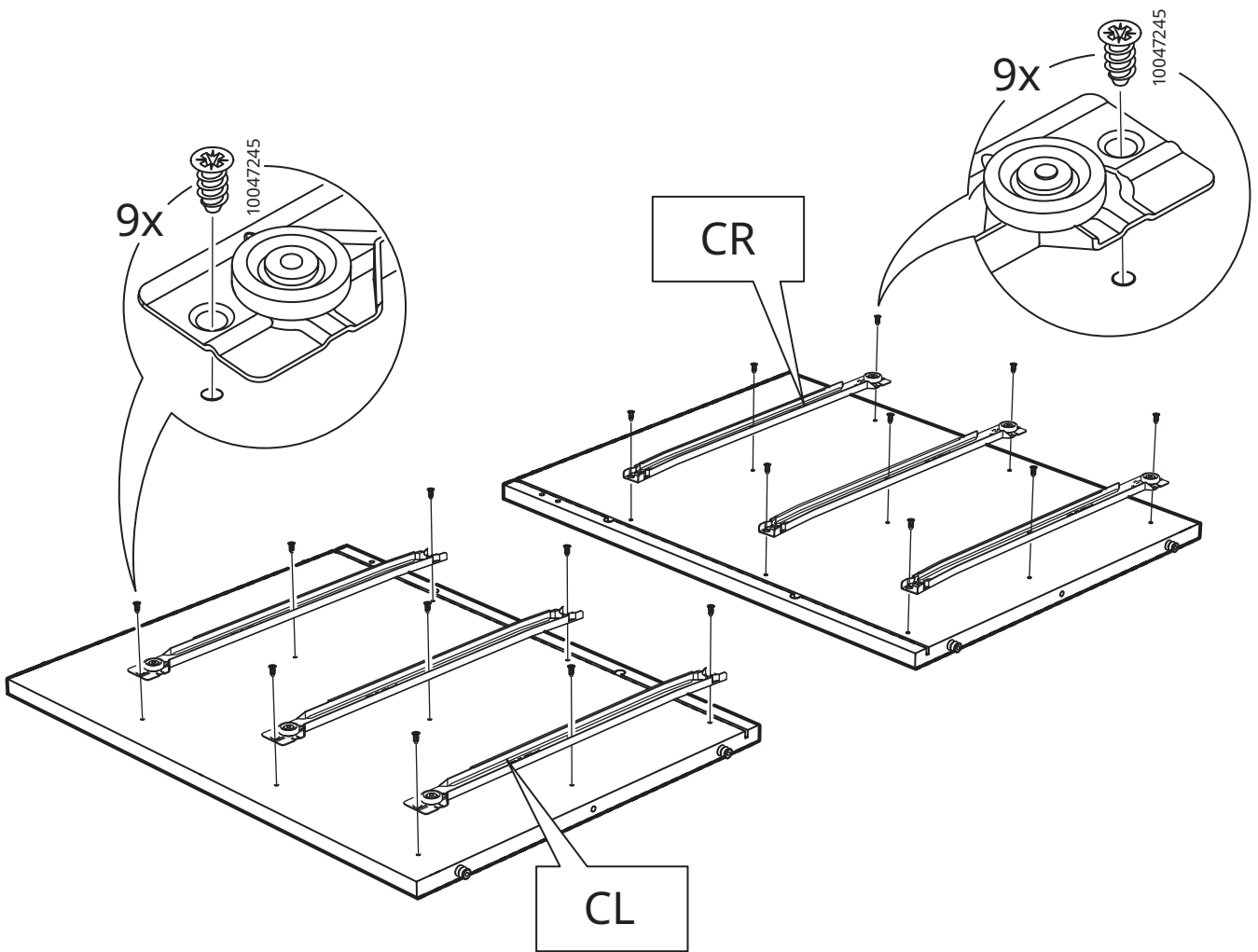

5

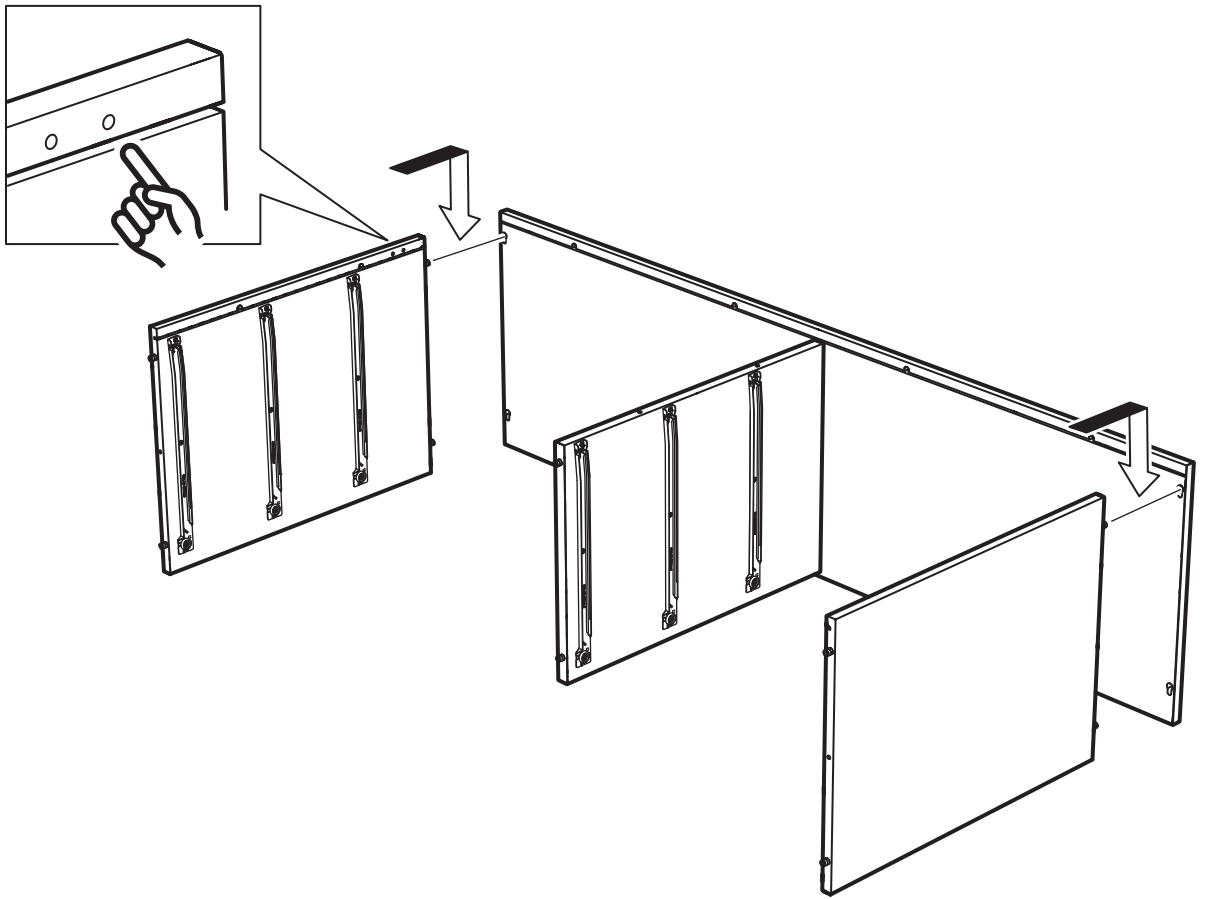

6

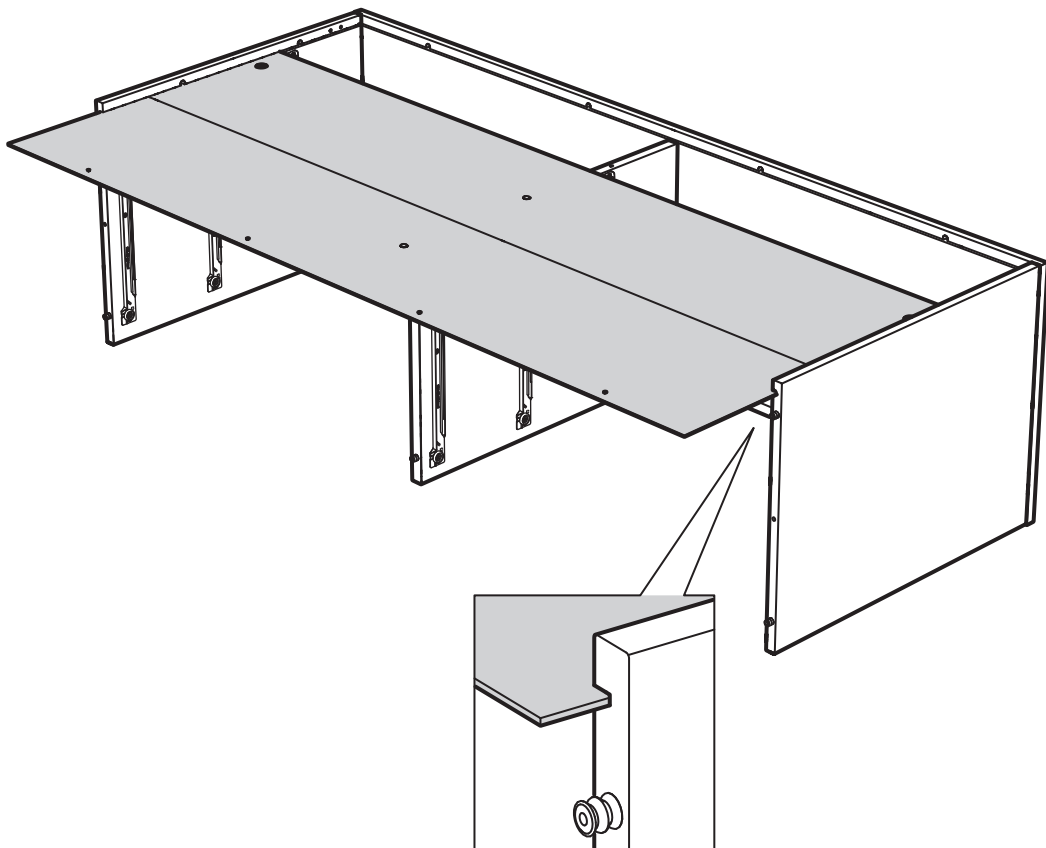

7

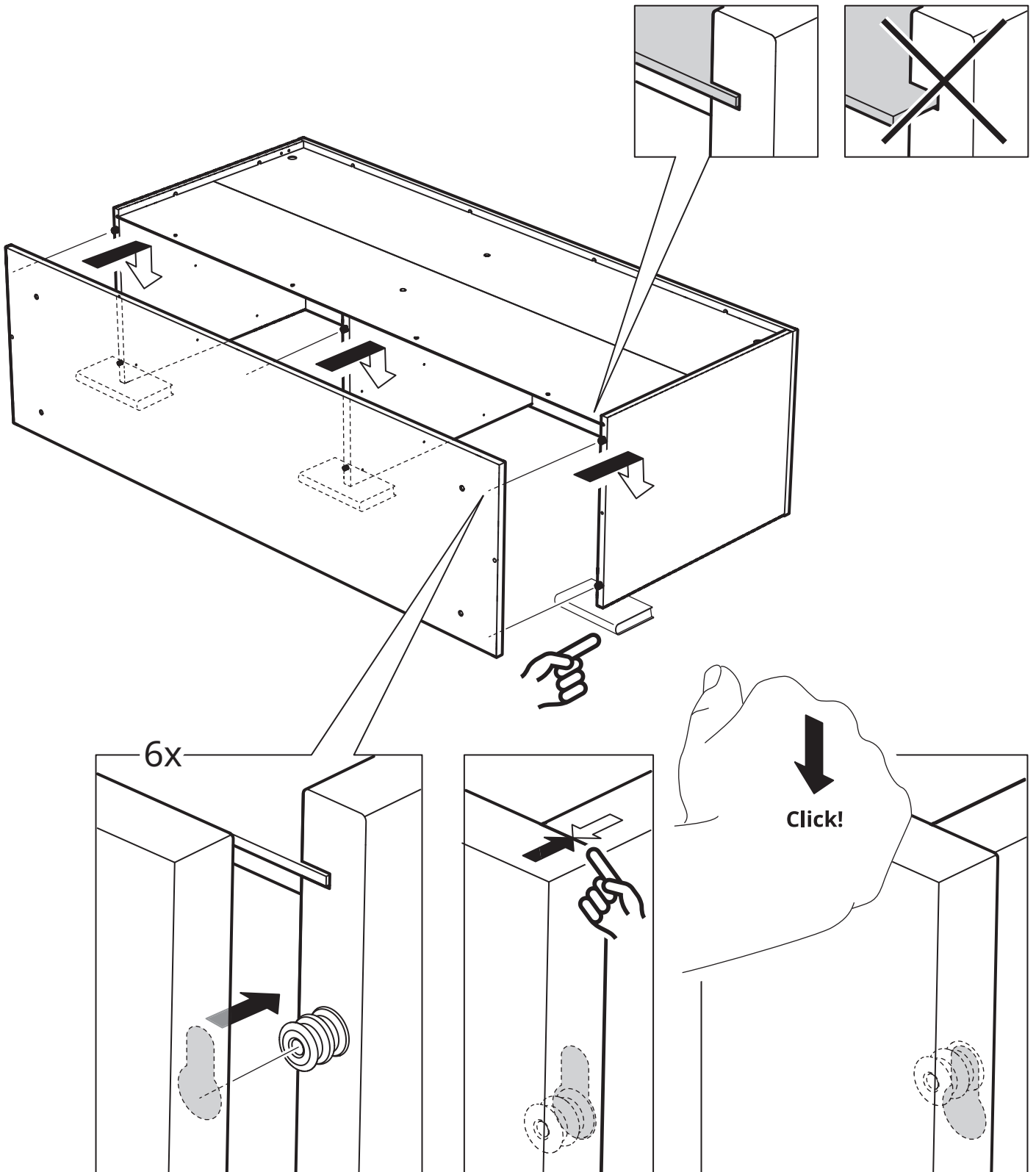

8

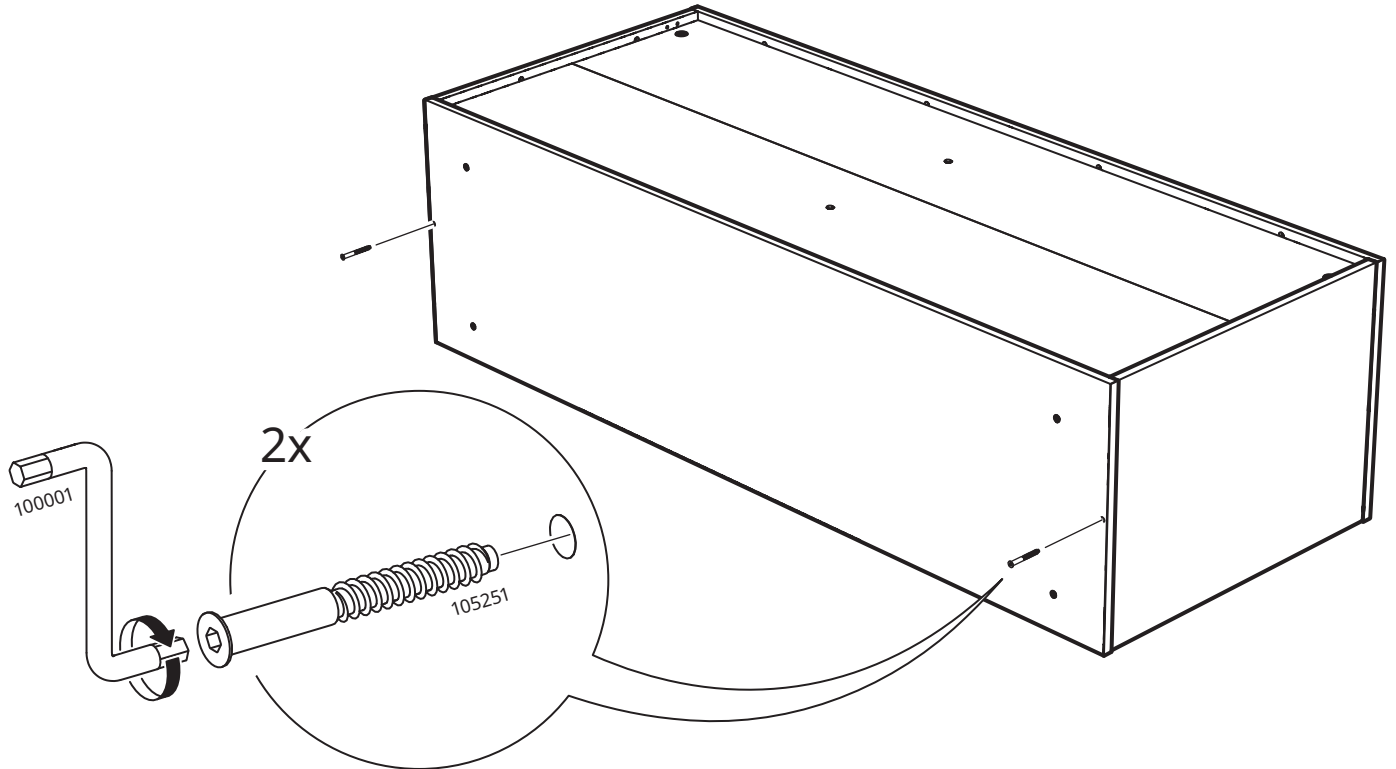

9

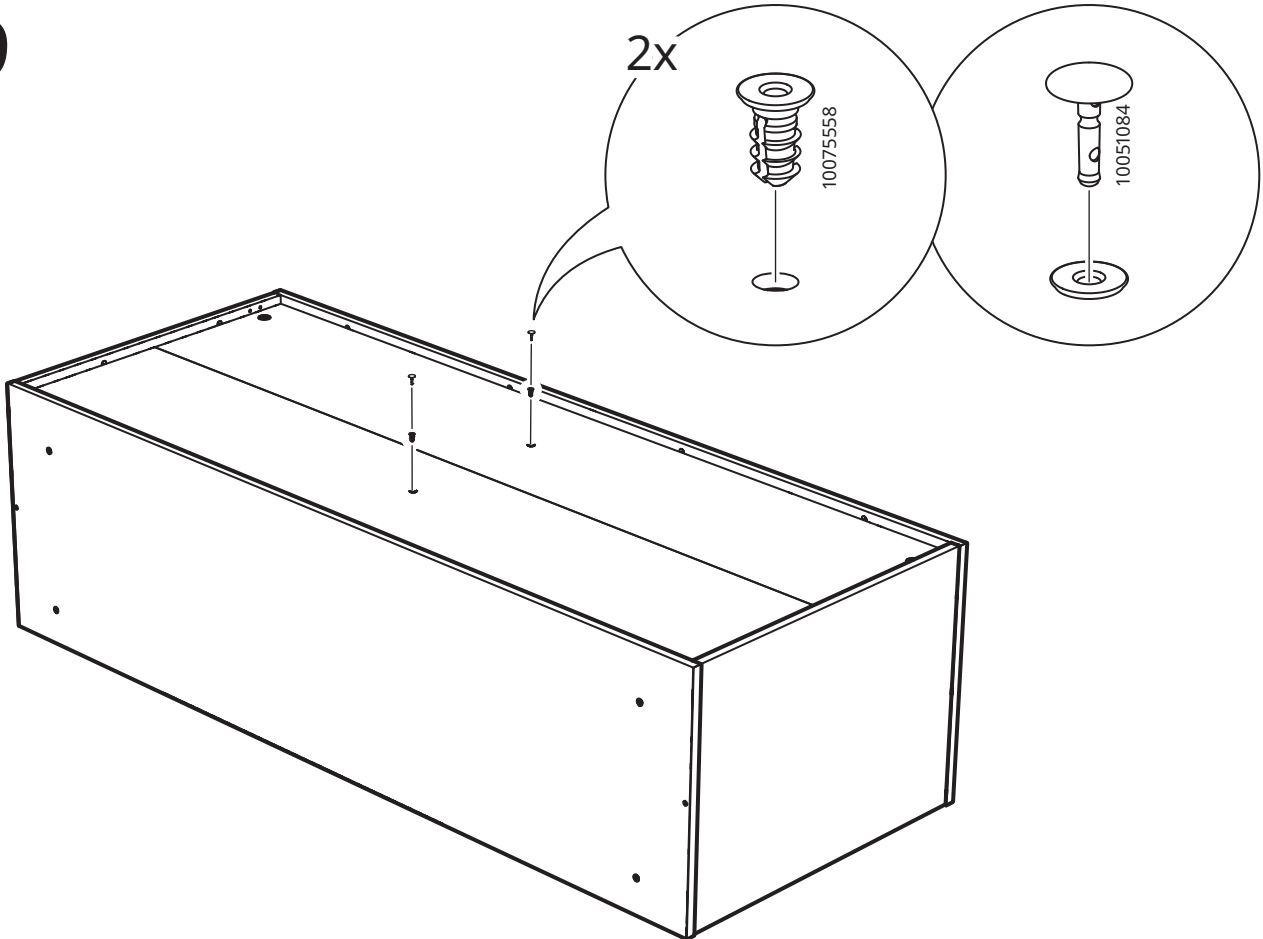

10

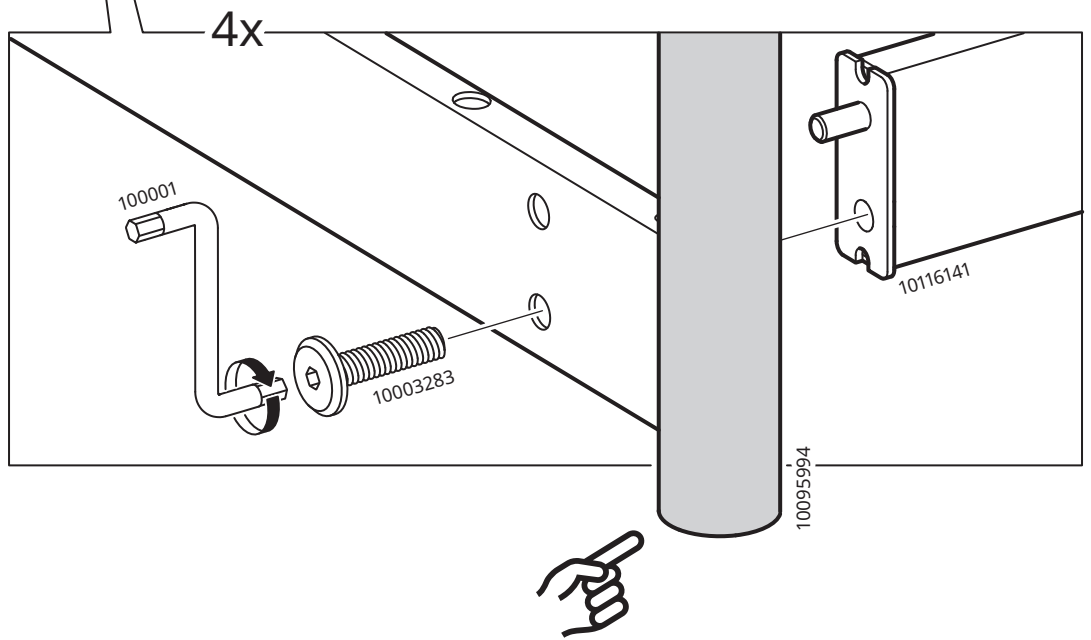
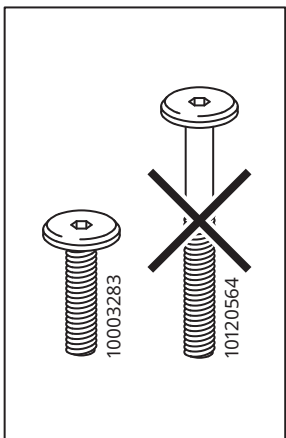
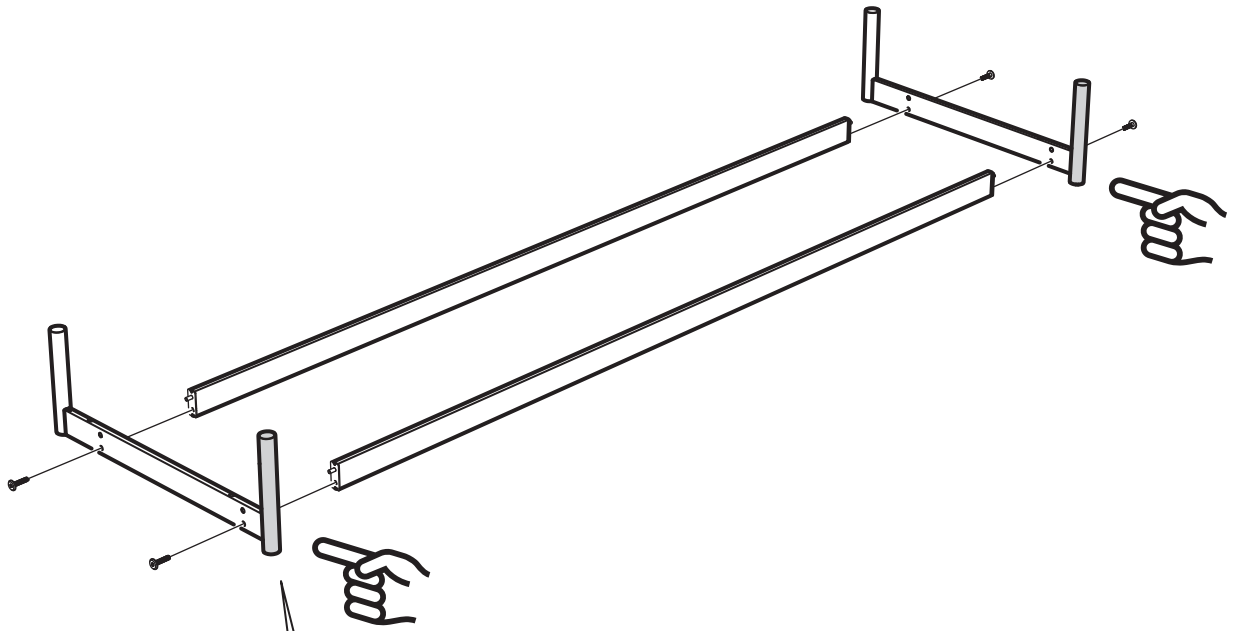

11

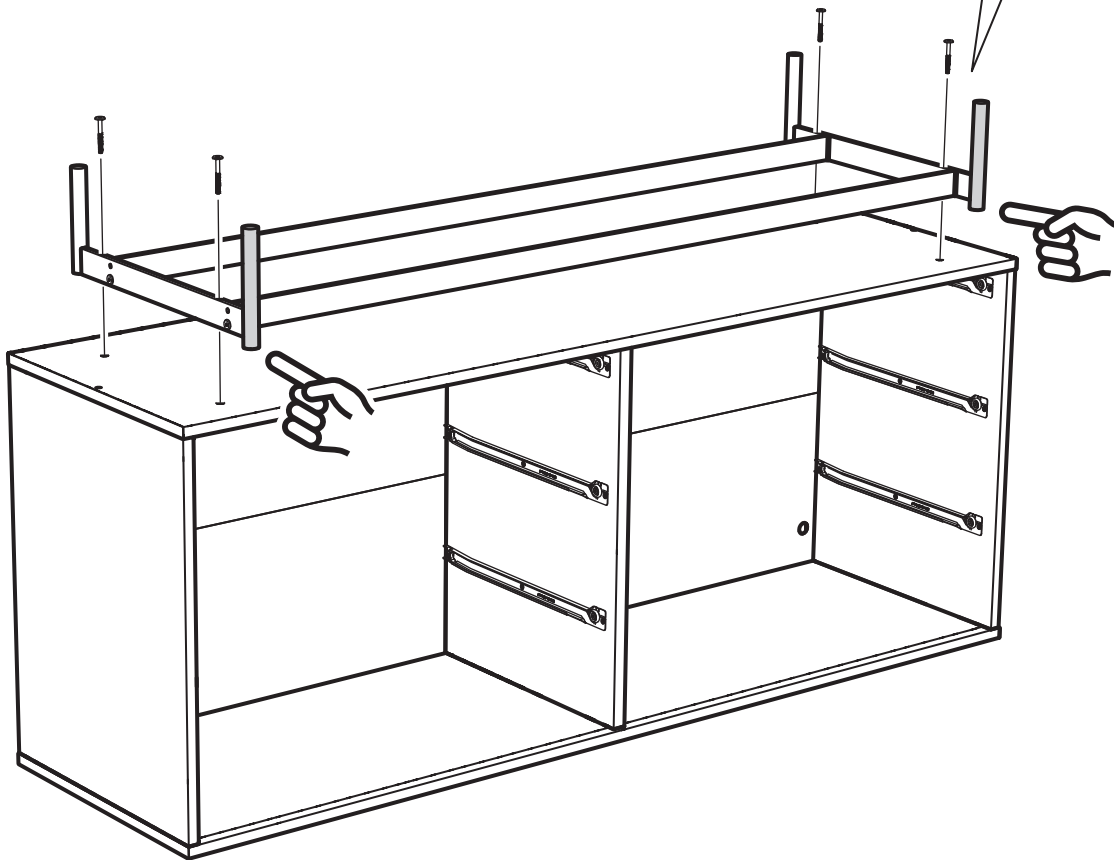
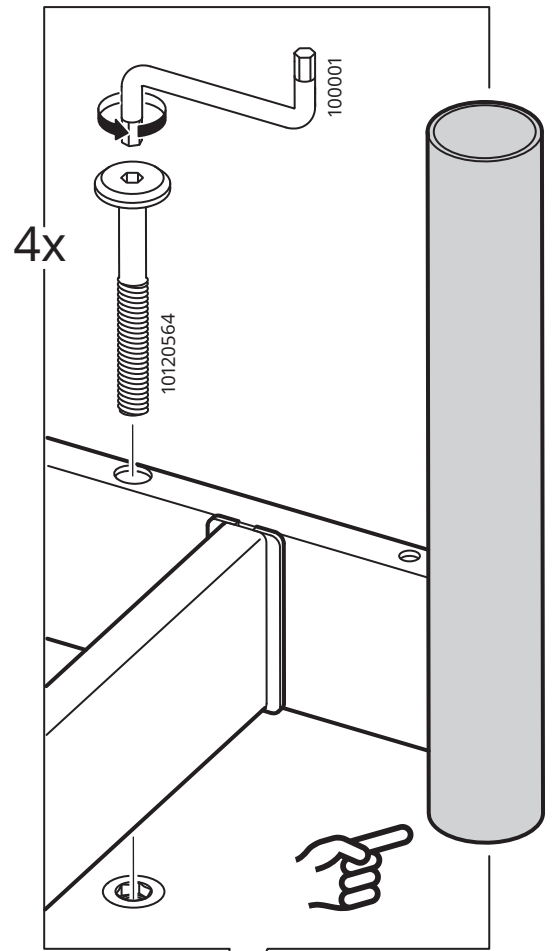
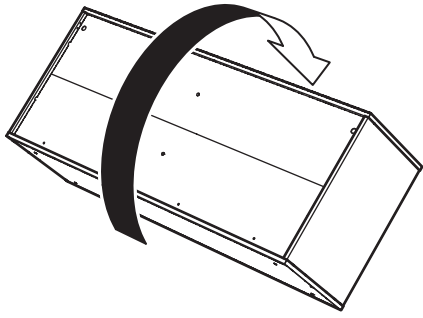

12

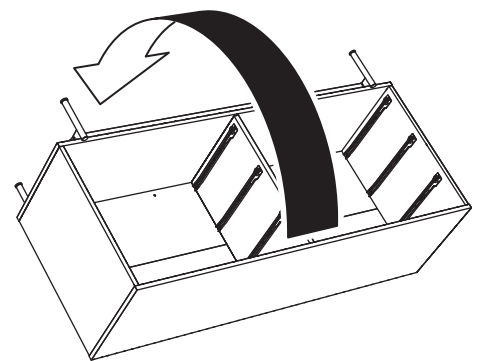
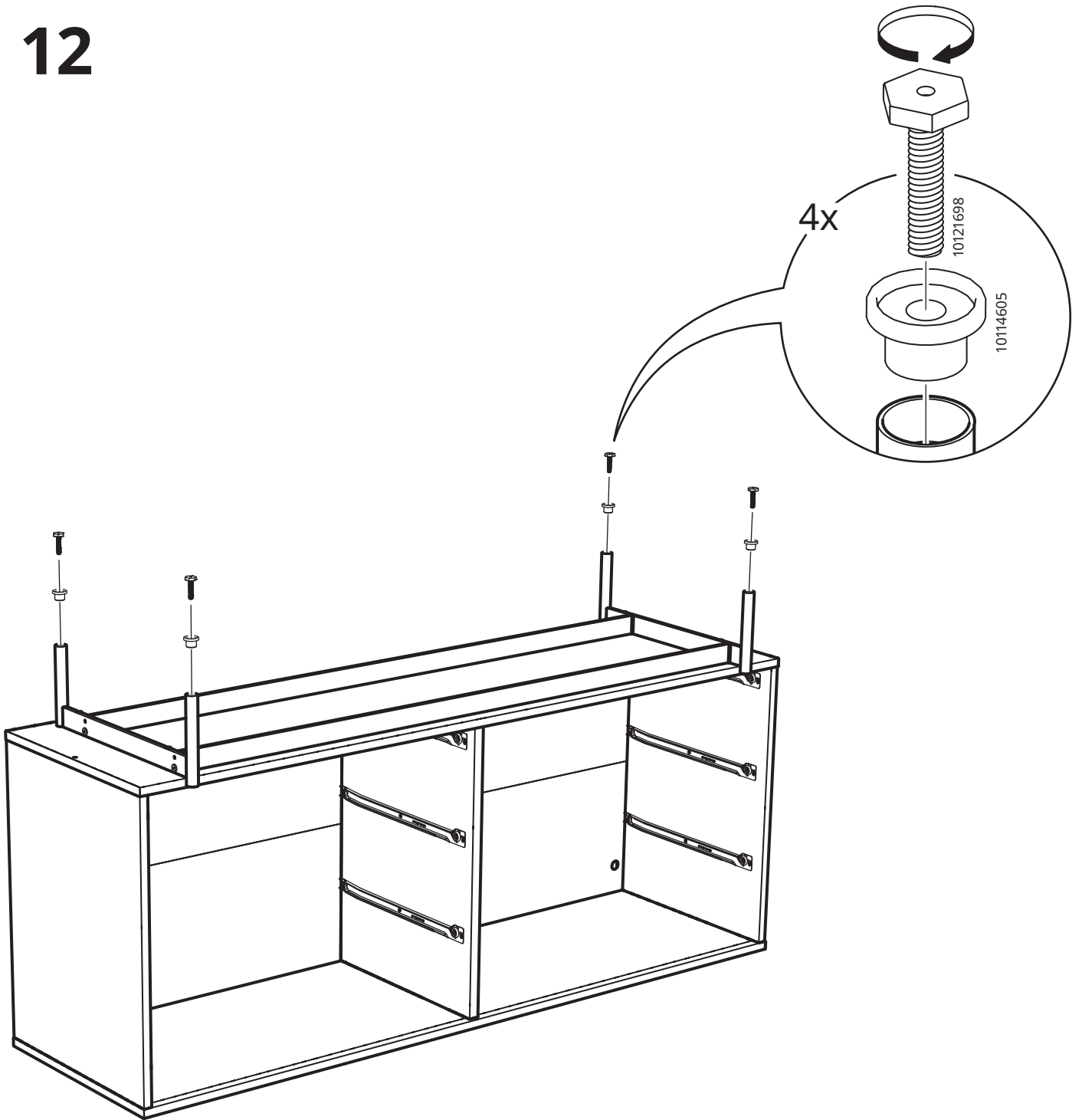

13

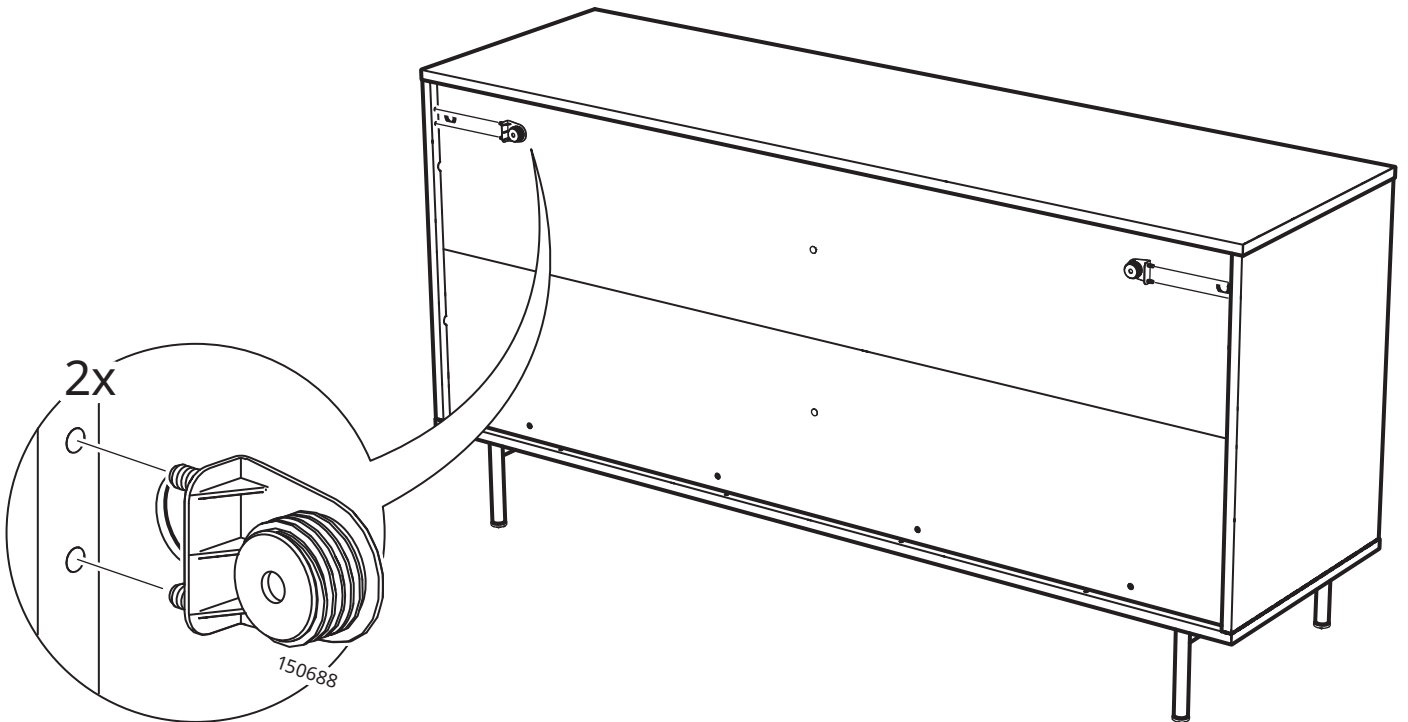
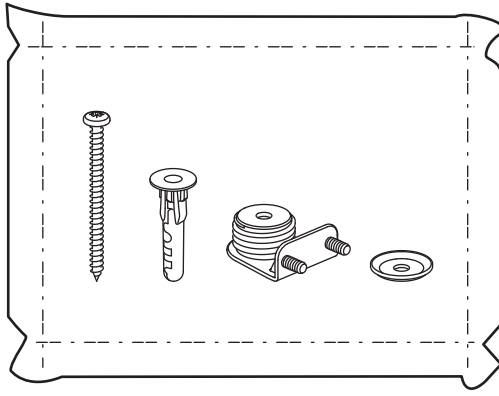

14

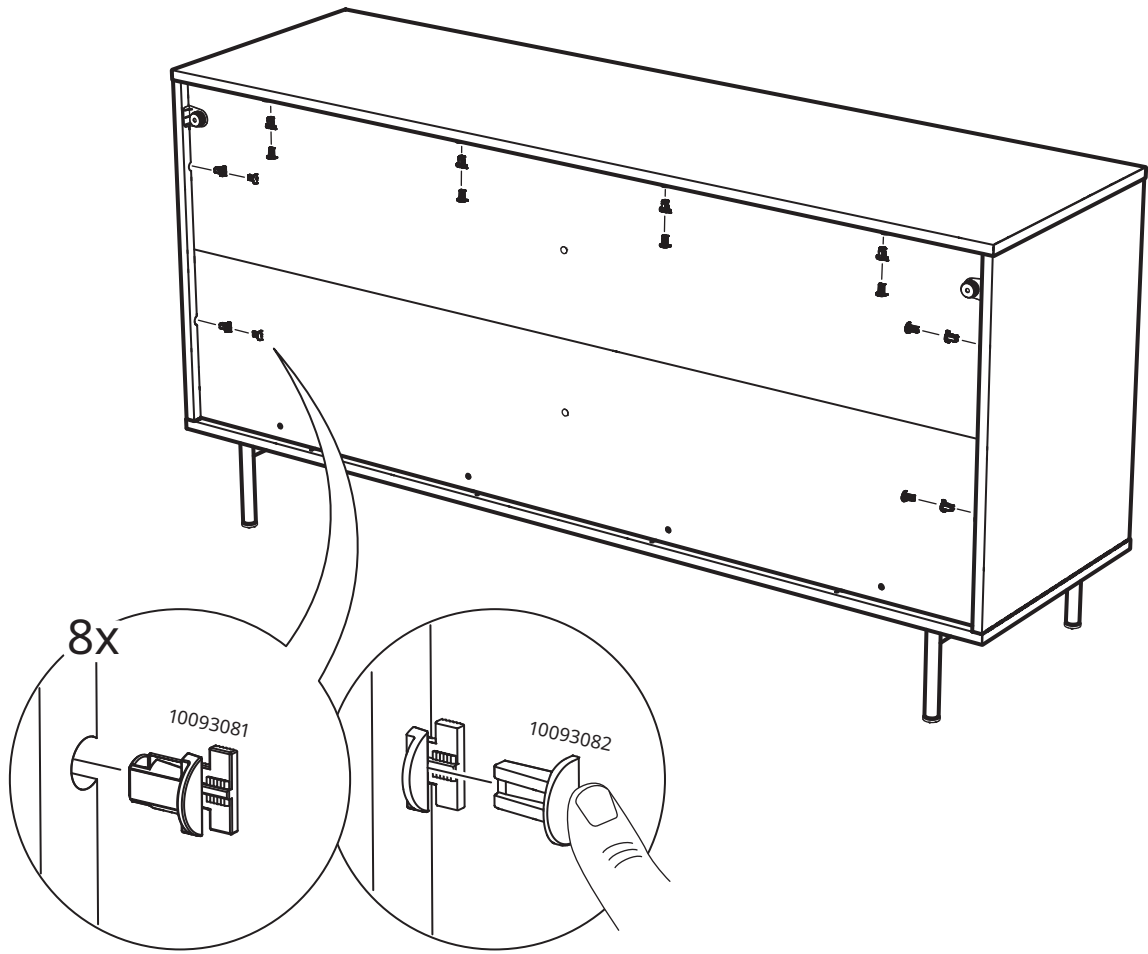

15

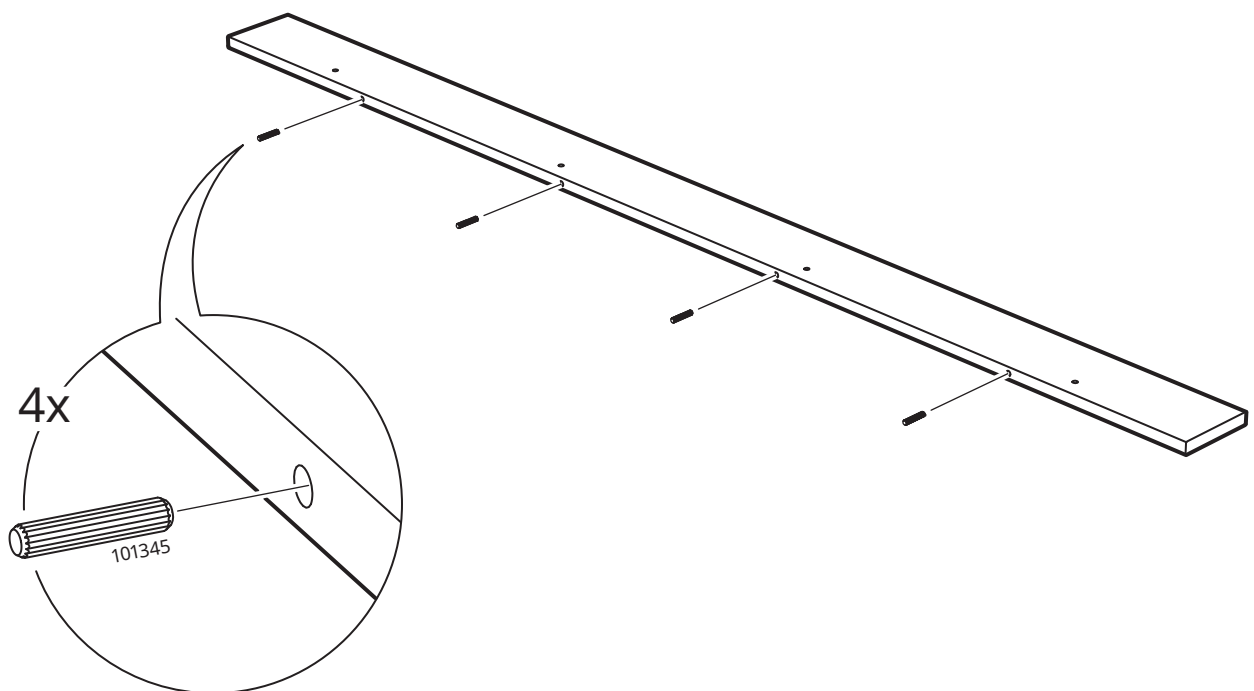

16

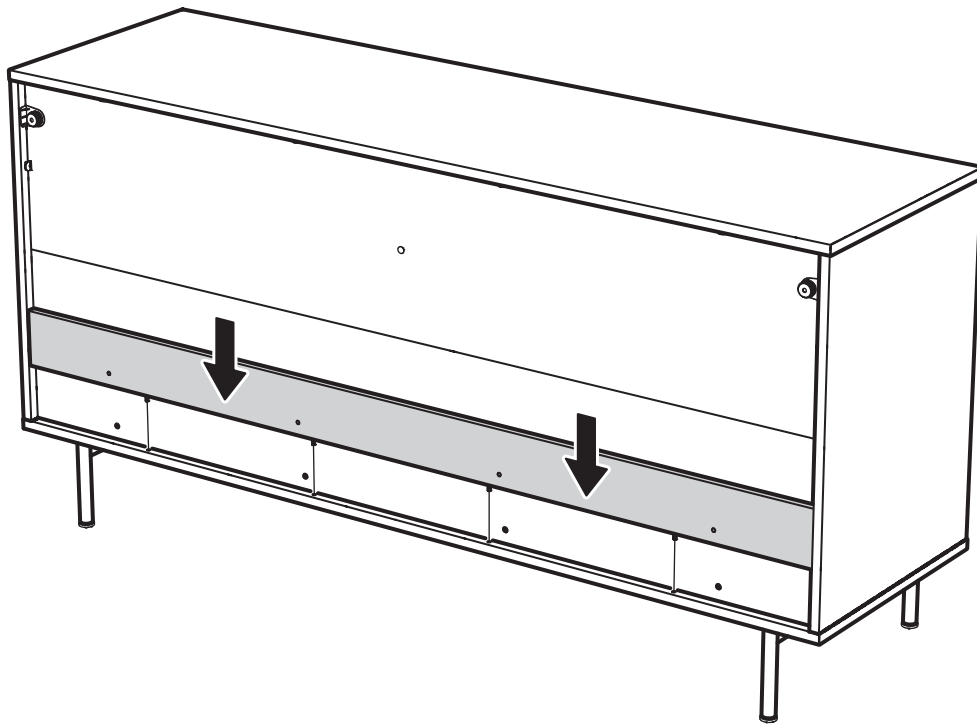

17

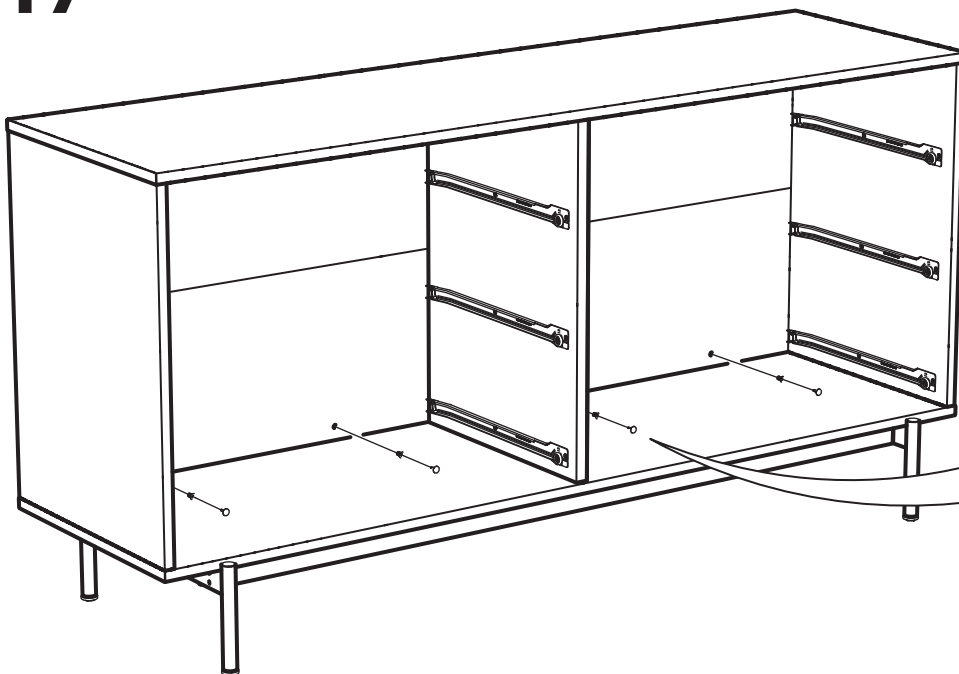

4x

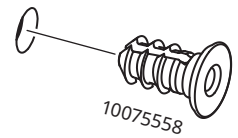

10075558

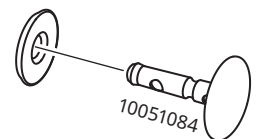

10051084

18



19

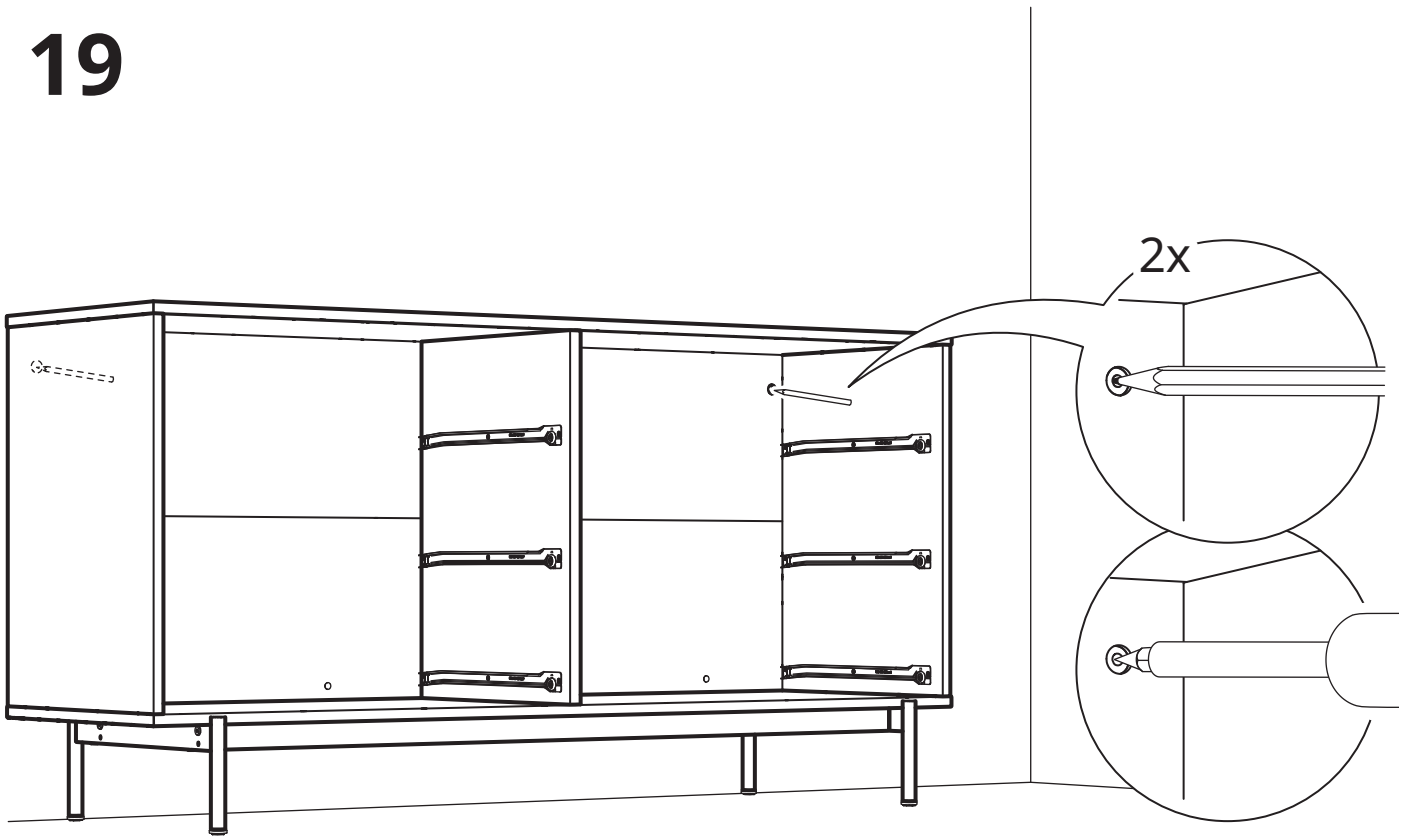

20

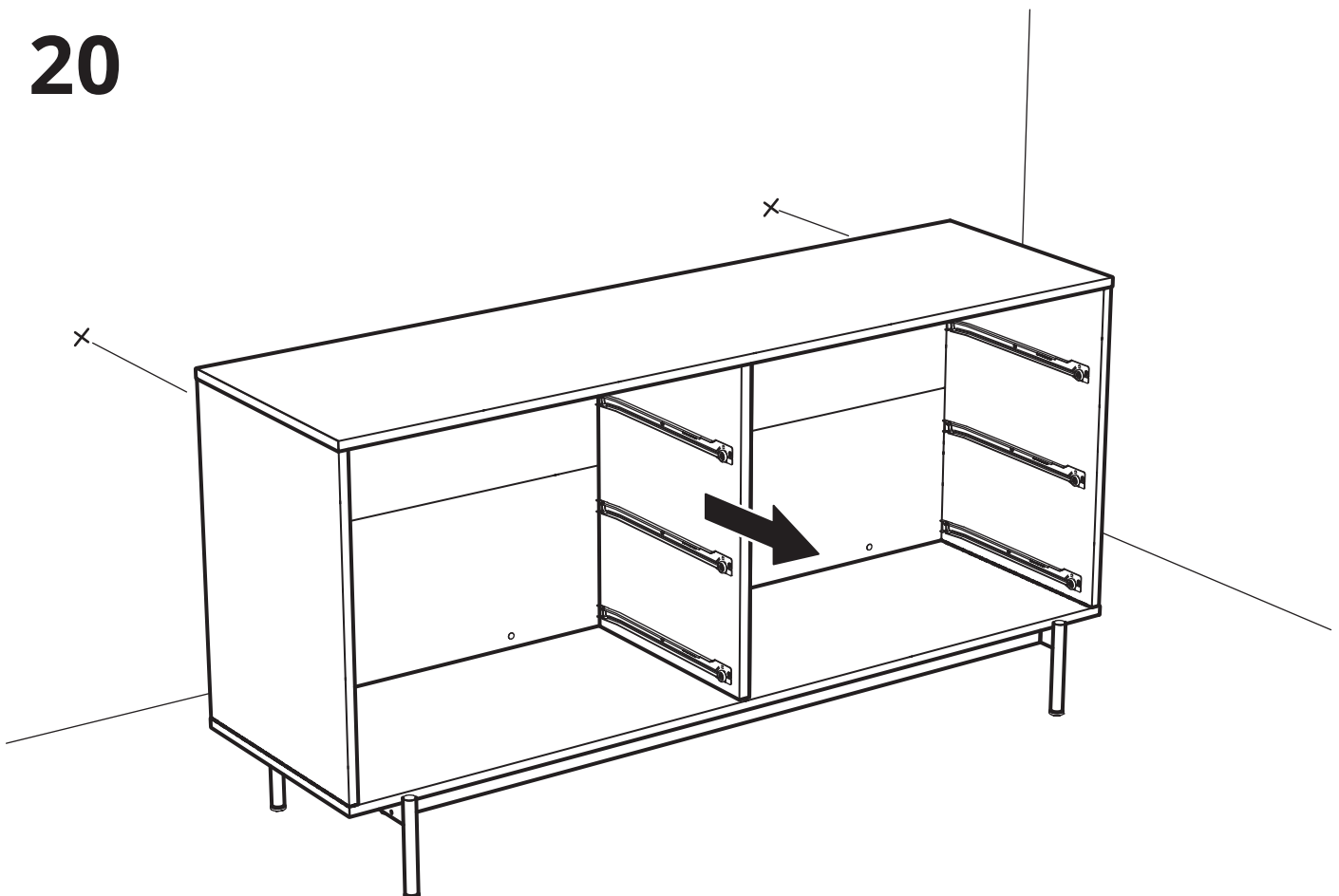



www.IKEA.com/secure-it



www.IKEA.cn/secure-it

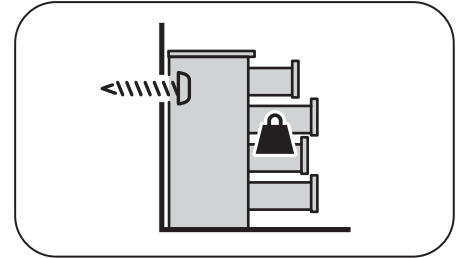

21

Español

Los tornillos y tacos incluidos se pueden utilizar en la mayor parte de las paredes sólidas (A) o huecas (B). Para la madera maciza (C), usa los tornillos sin tacos. Si tienes dudas, acude a un experto.

Català

Els cargols i els tacs inclosos es poden fer servir a la majoria de les parets sòlides (A) o buides (B). Per a la fusta massissa (C), fes servir els cargols sense tacs. Si tens cap dubte, consulta un expert.

Euskara

Produktuak dakartzan torlojuak eta takoak horma solido (A) eta huts (B) gehienetan erabili ahal dira. Egur trinkoen (C) kasuan, ez erabili takoak torlojuekin. Zalantzarik baduzu, galdetu aditu bati.

Galego

Os parafusos e tacos incluídos pódense utilizar na maior parte das paredes sólidas (A) ou ocas (B). Para a madeira maciza (C), emprega os parafusos sen tacs. Se tes dúbidas, acude a un experto.

A

Ø 8 mm (5/16")

1

70 mm (2 3/4")

2

27

B

Ø 8 mm (5/16")

1

≈ 30 mm (≈ 1 1/4")

2

28

C

Ø 3 mm (1/8")

1

≈ 30 mm (≈ 1/4")

30

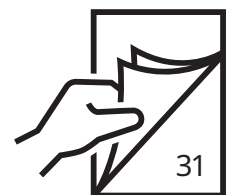
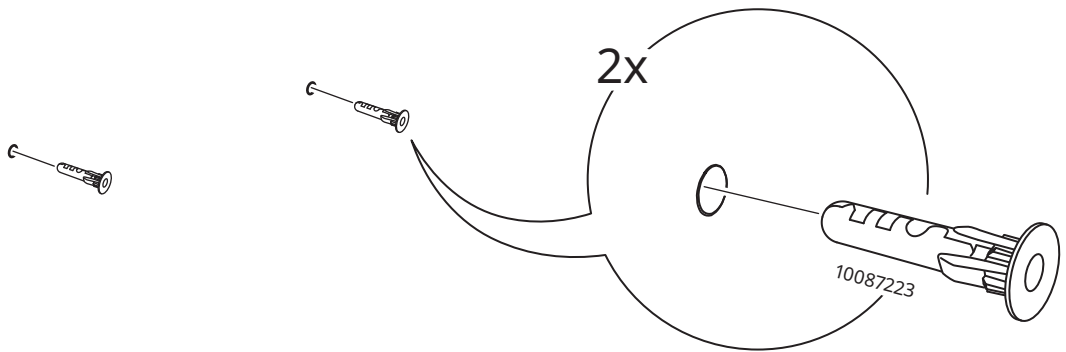
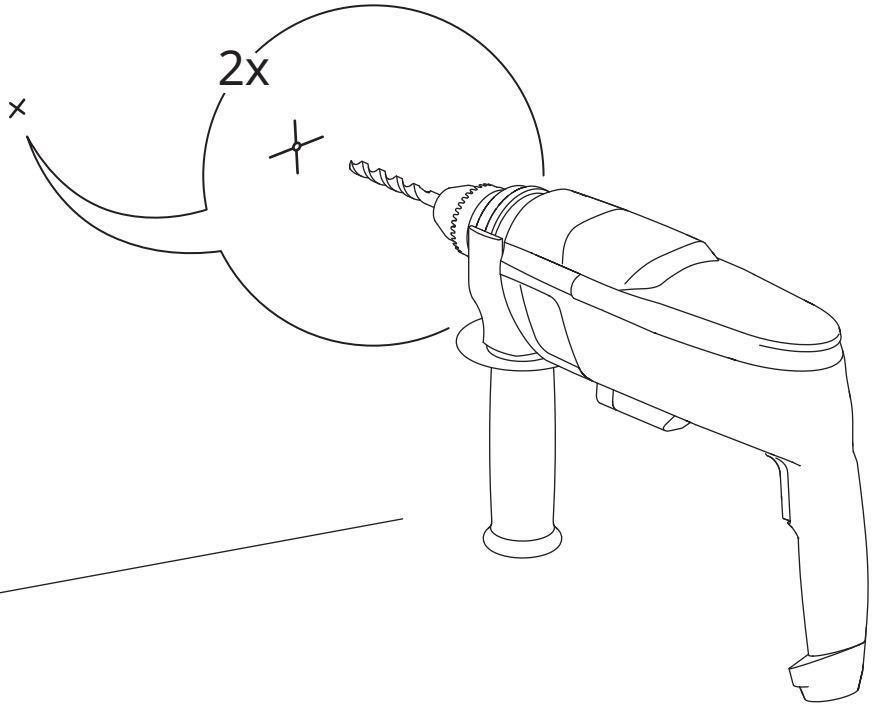
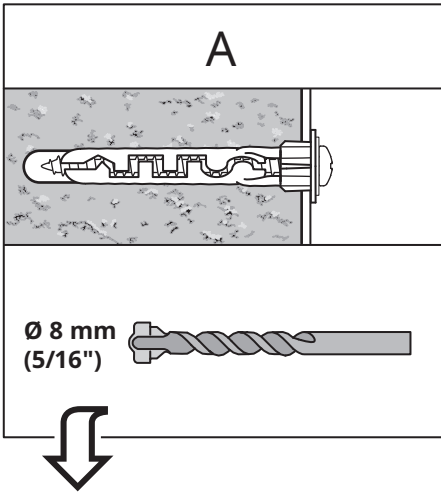

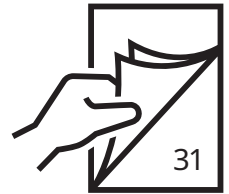
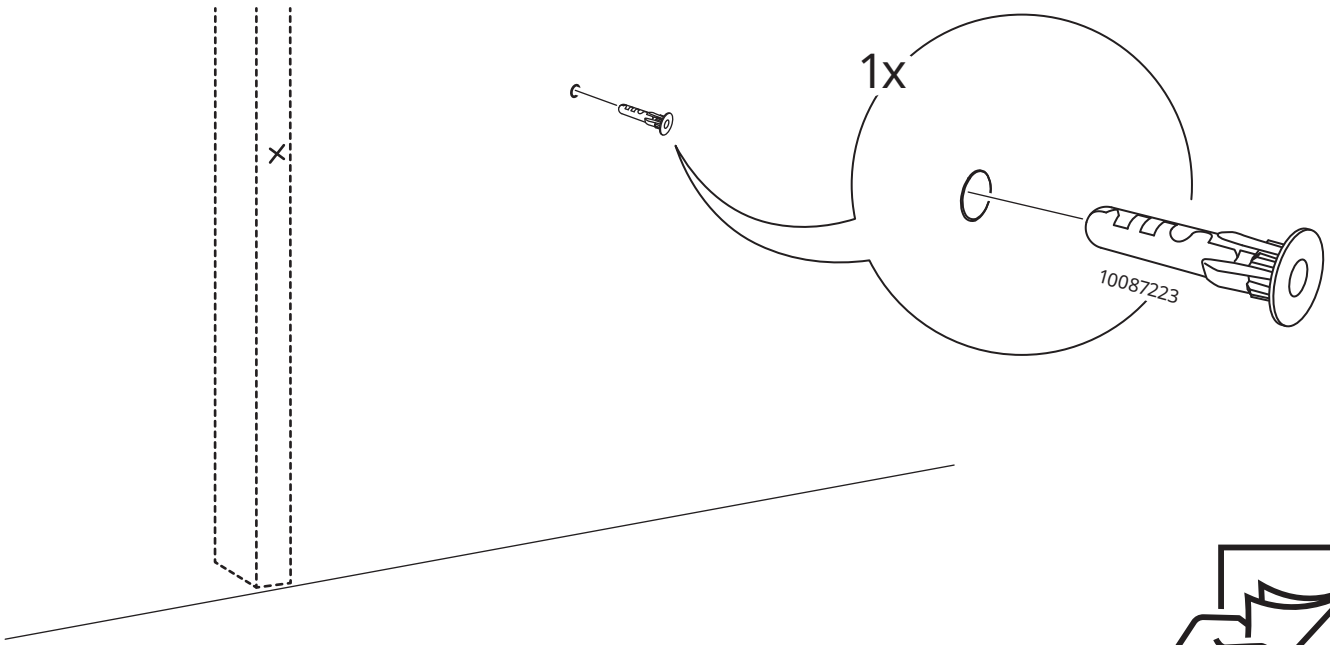

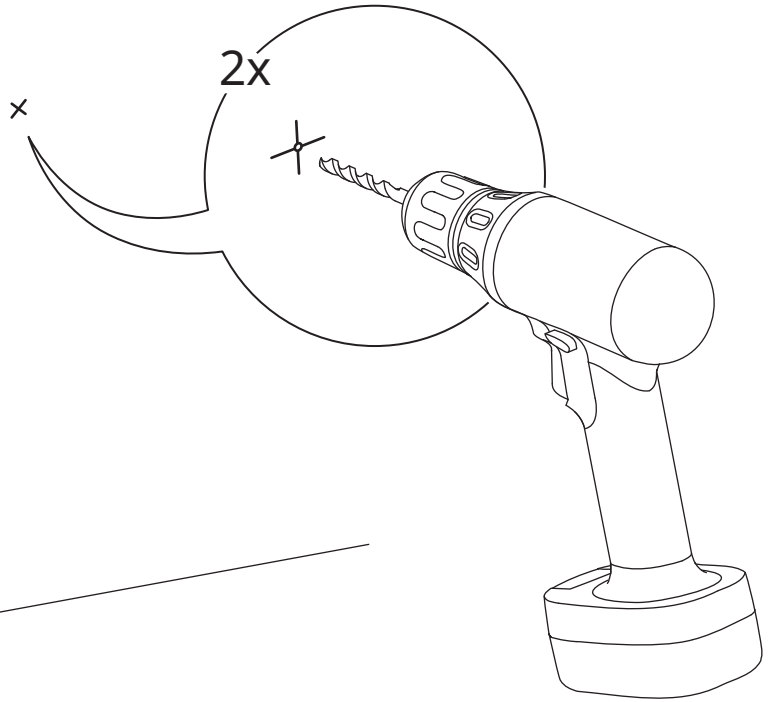
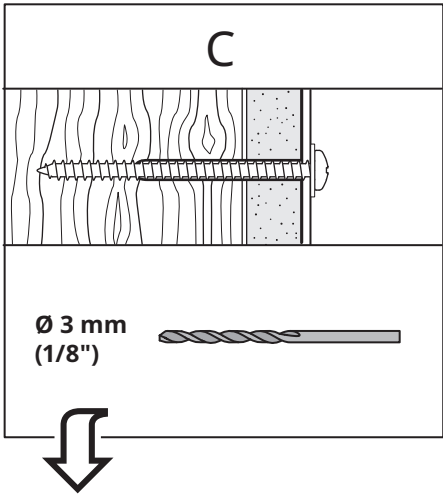

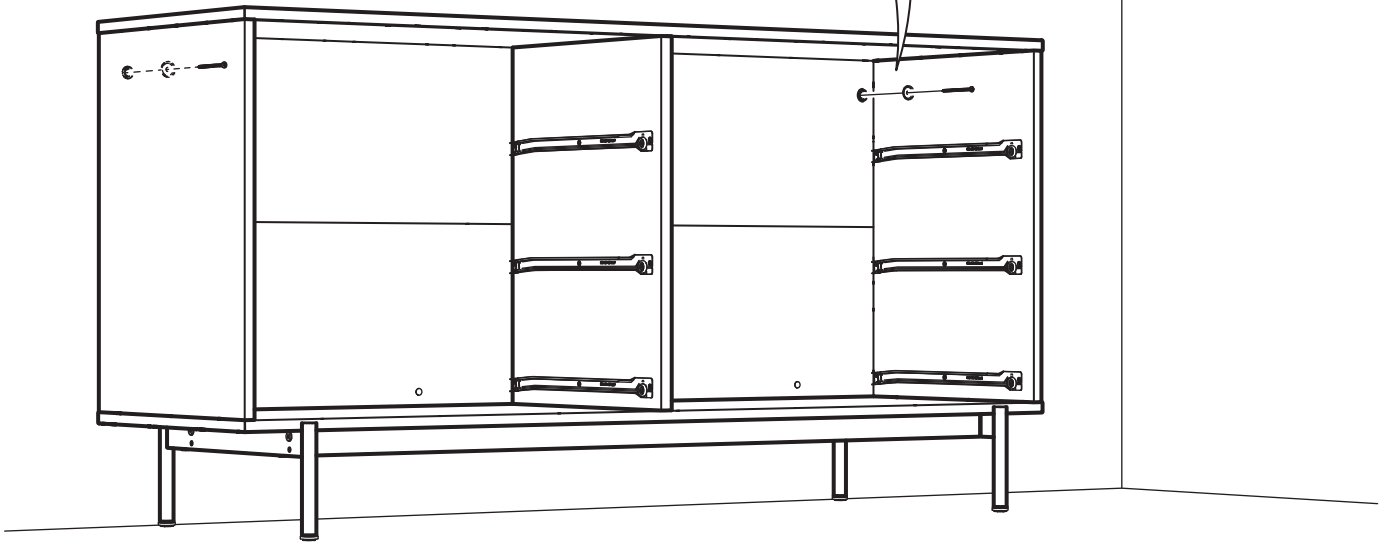
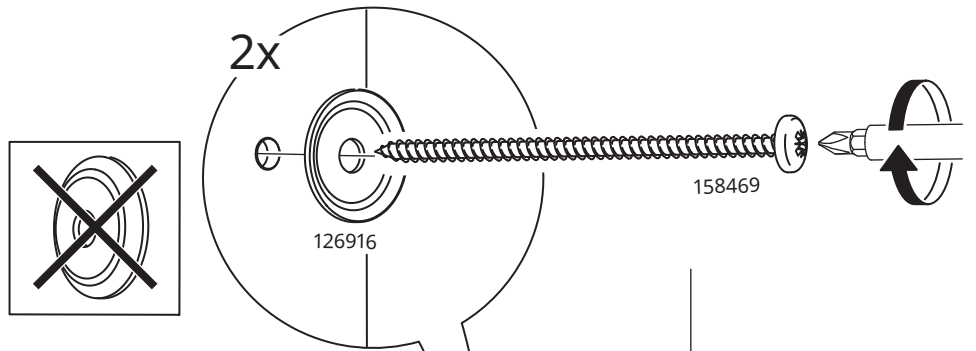

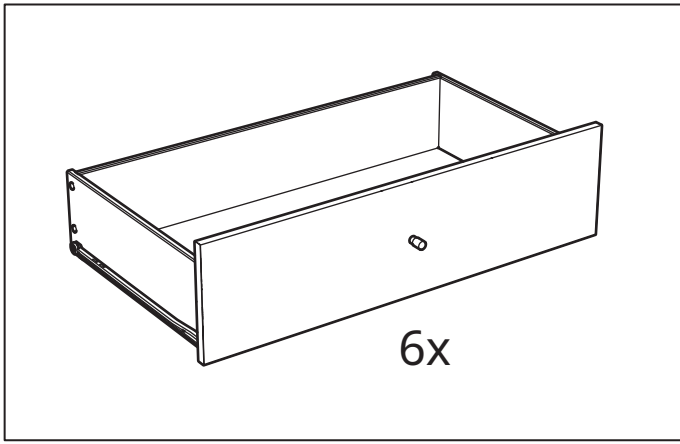

23

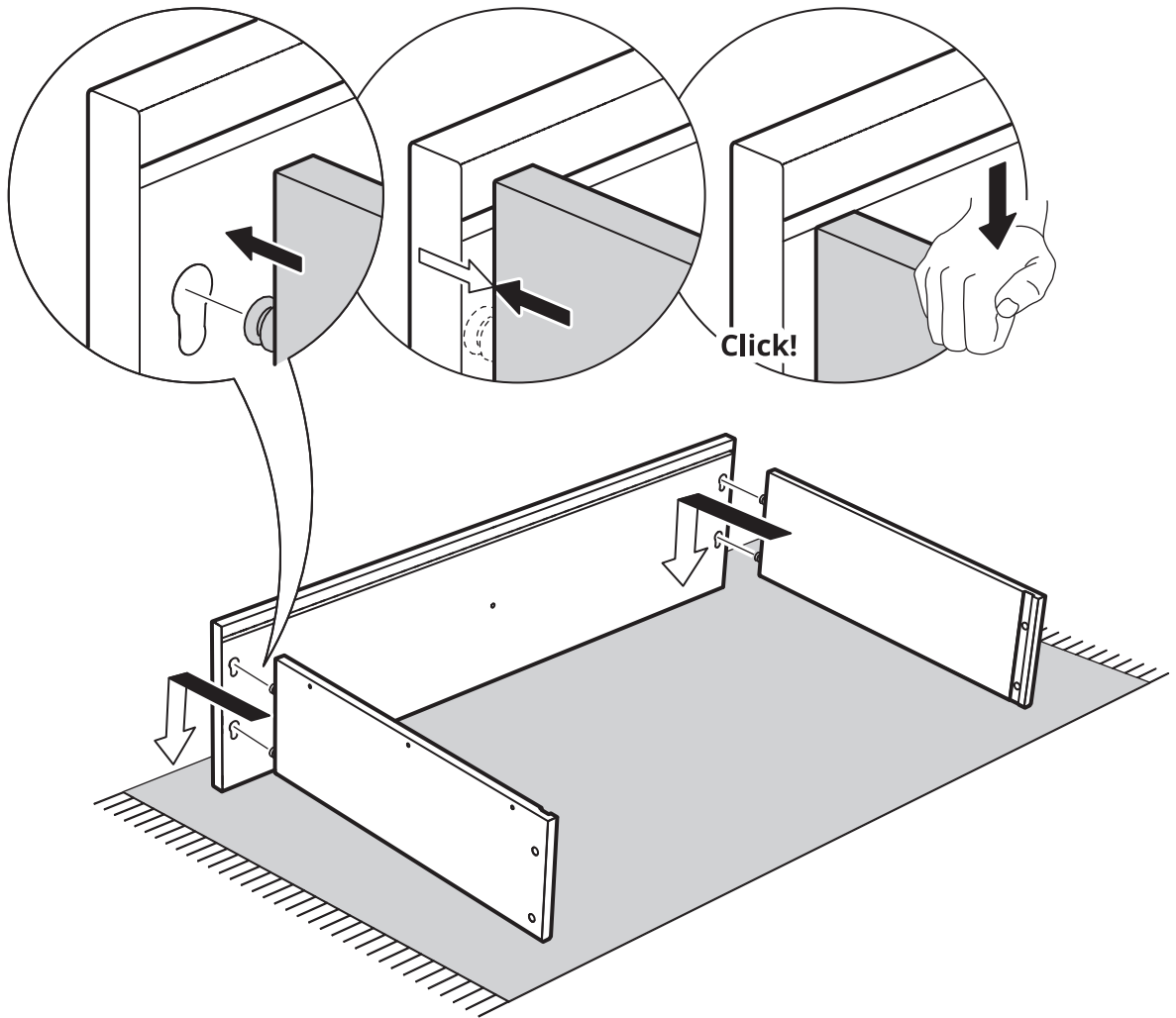

24

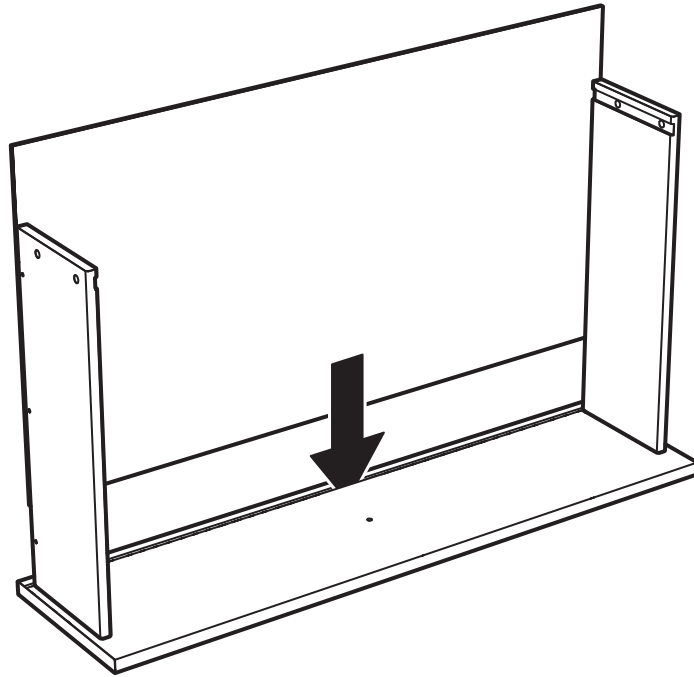
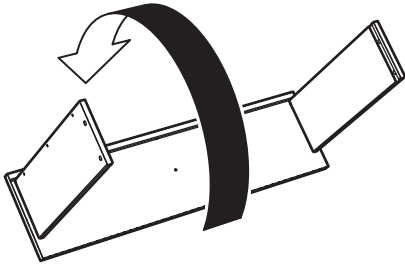

25

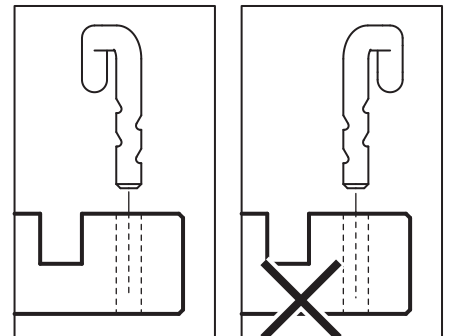
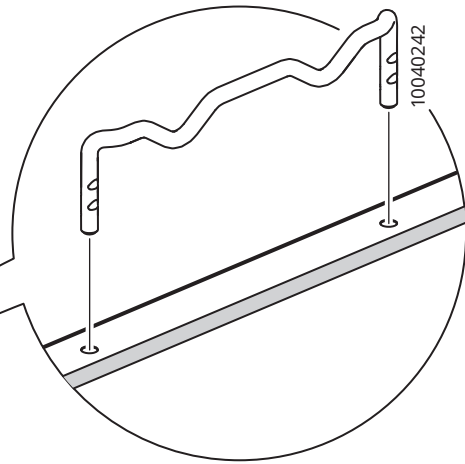
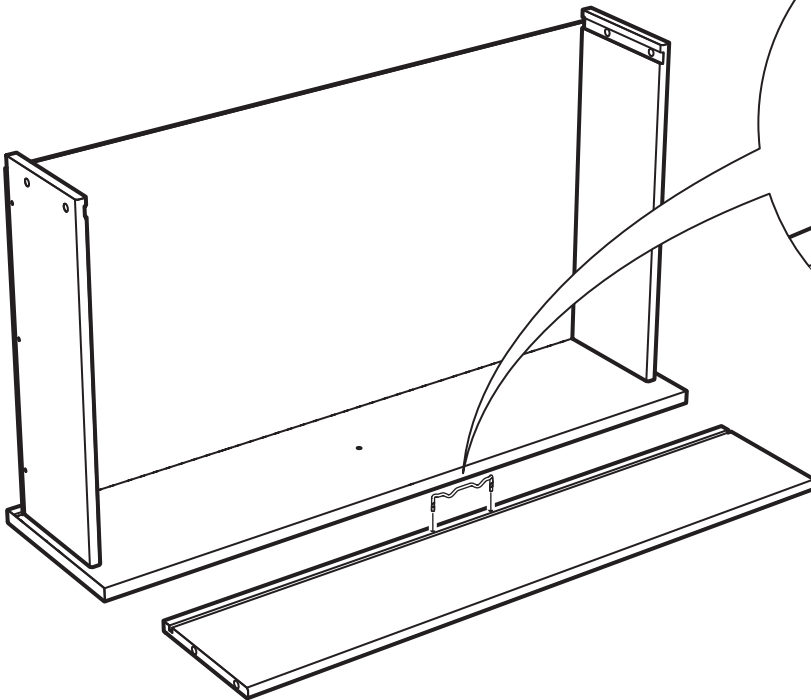

26

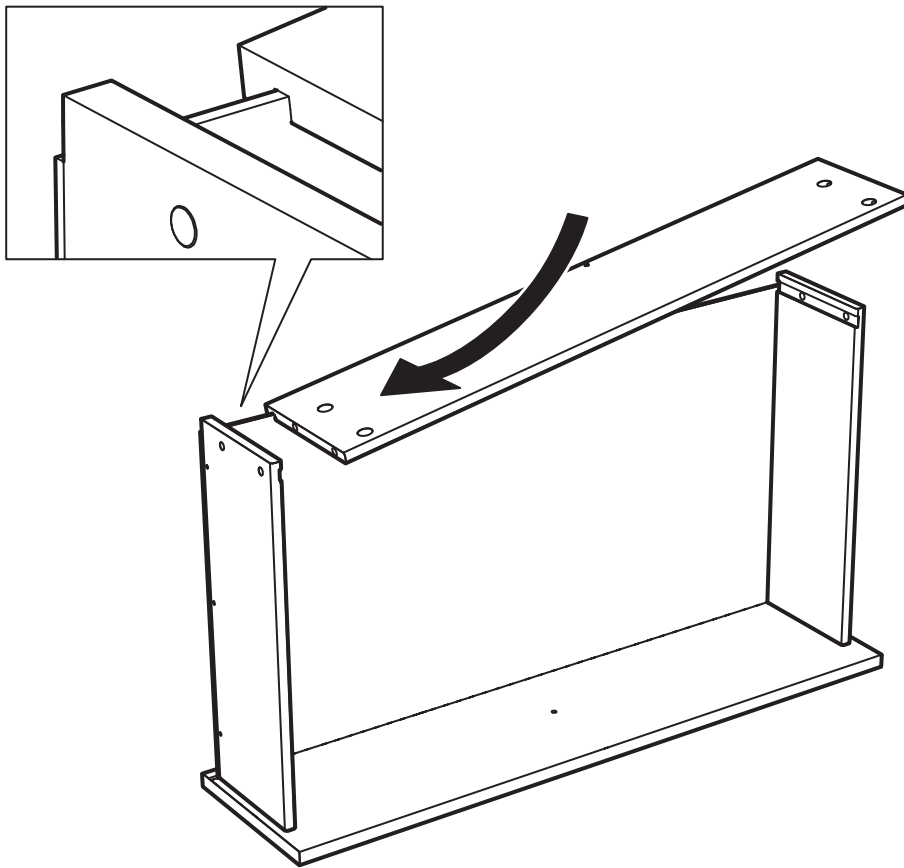

27

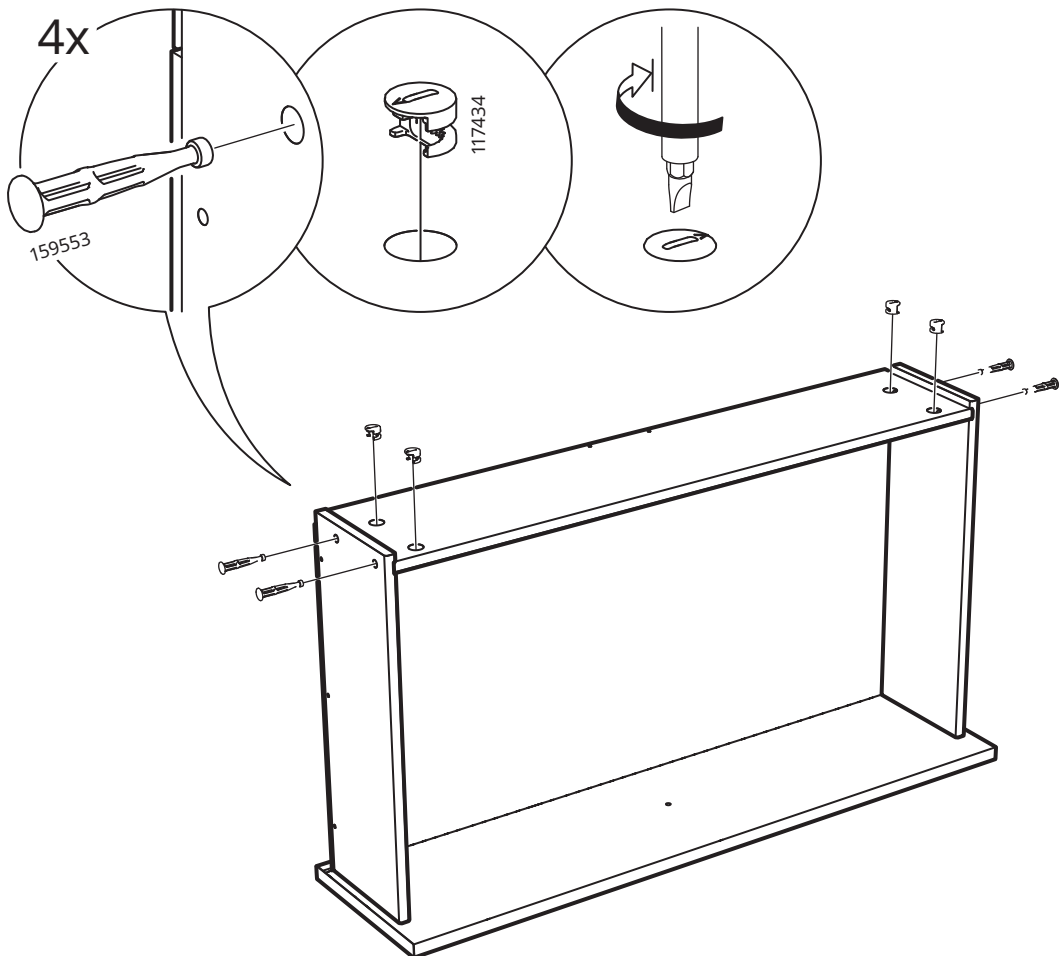

28

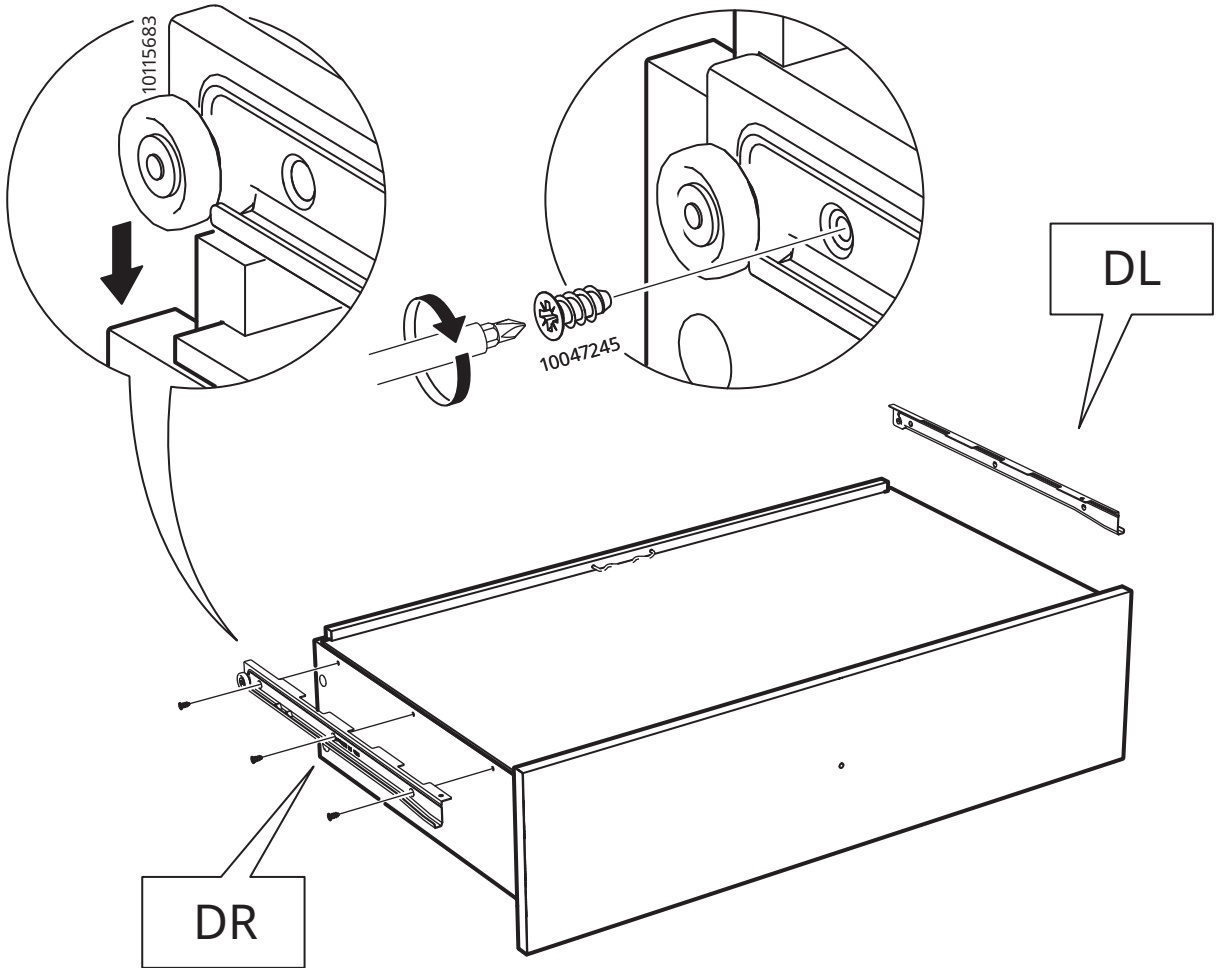

29

