

# IDANÄS

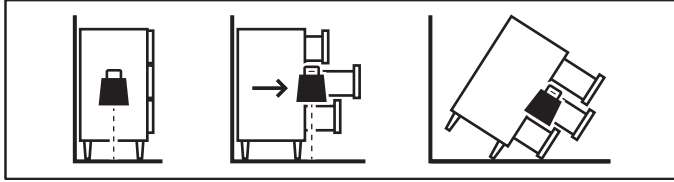

Design and Quality  
IKEA of Sweden



Euskara

## OHARRA

**Altzaria erortzen bada, lesio oso larriak edo heriotza izan daitezke ondorioak.**

**Finkatu BETI altzaria hormara, iraulketak saihesteko osagarriak erabiliz.**

**Altzaria iraultzeko eta lesio oso larriak edo heriotza eragiteko arriskua are gehiago murrizteko:**

- Gorde objekturik astunenak beheko tiraderan.
- Ez jarri telebista edo antzeko objektu astunak altzariaren gainean.
- Ez utzi haurrei altzarietara igotzen, ez eta tiradera, ate edo apaletatik zintzilikatzen ere.

Català

## ADVERTÈNCIA

**Si el moble es bolca, pot provocar lesions greus o fins i tot la mort.**

**Colla SEMPRE aquest moble a la paret amb els accessoris antibolcada.**

**Per reduir encara més el risc de lesions greus o la mort provocades per la caiguda d'un moble:**

- Desa els objectes més pesants al calaix inferior.
- No posis un TV altres objectes pesants sobre aquest producte.
- Evita que els infants pugin sobre el moble o es pengin dels calaixos, les portes o els prestatges.

Galego

## ADVERTENCIA

**Se o moble envorca, pode provocar lesións moi graves e mesmo mortais.**

**Fixa SEMPRE este moble á parede utilizando os accesorios antienvorcadura.**

**Para reducir aínda máis o risco de que se produzan lesións graves ou mesmo mortais causadas pola envorcadura do moble:**

- Garda os obxectos máis pesados no caixón inferior.
- Non coloques un televisor ou outros obxectos pesados enriba deste produto.
- Evita que os nenos suban enriba do moble ou se colguen dos caixóns, portas ou estantes.

Español

## ADVERTENCIA

**Si el mueble vuelca, puede provocar lesiones muy graves e incluso mortales.**

**Fija SIEMPRE este mueble a la pared utilizando los accesorios antivuelco.**

**Para reducir aún más el riesgo de lesiones graves o incluso mortales causadas por el vuelco del mueble:**

- Guarda los objetos más pesados en el cajón inferior.
- No pongas un TV u otros objetos pesados encima de este producto.
- Evita que los niños suban encima del mueble o se cuelguen de los cajones, las puertas o los estantes.

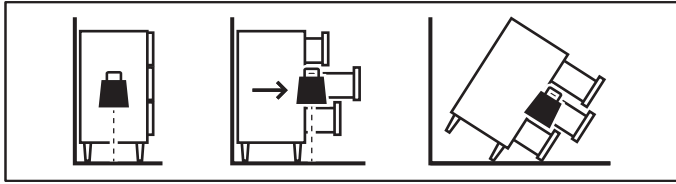

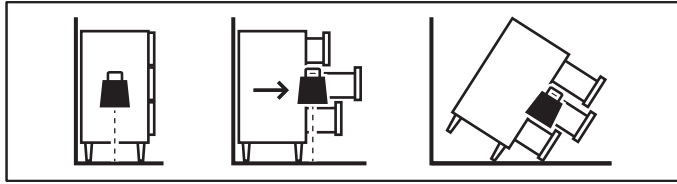

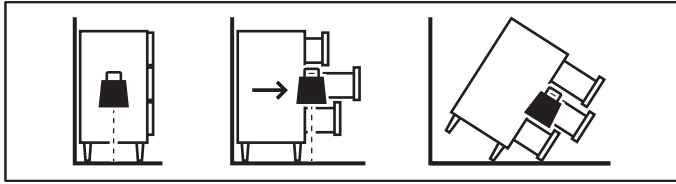

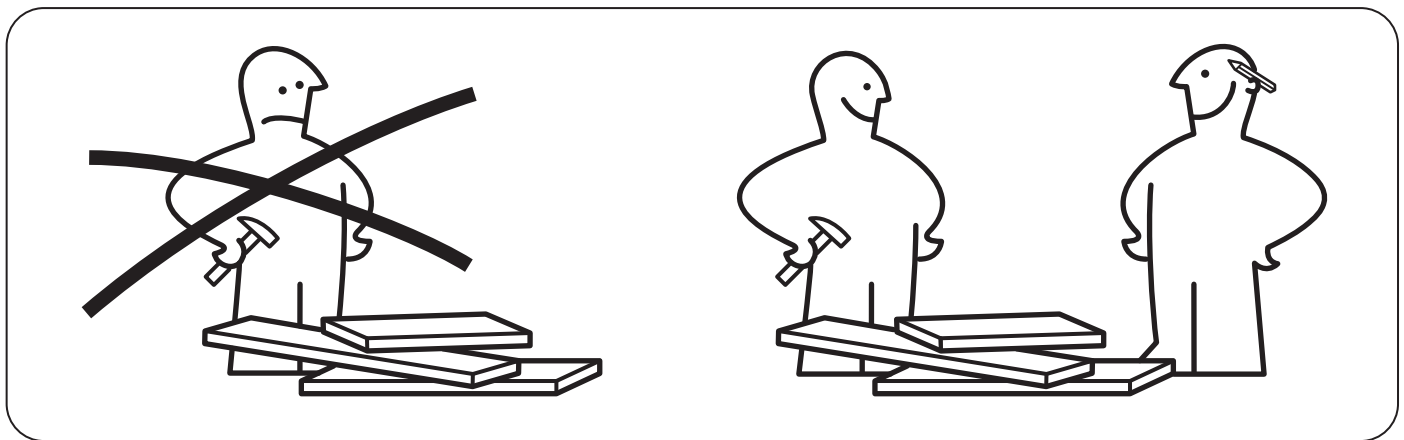
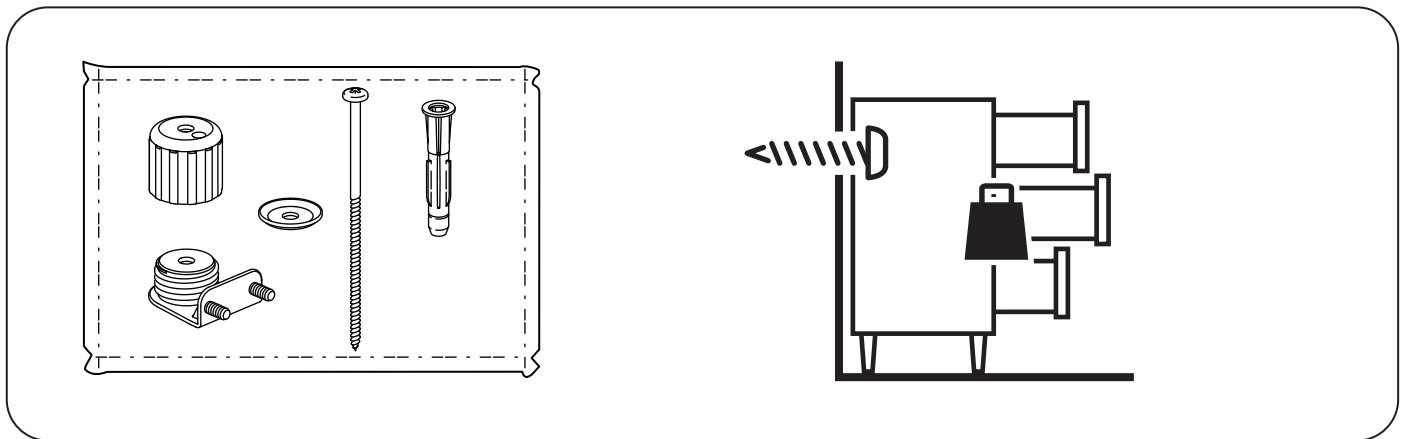
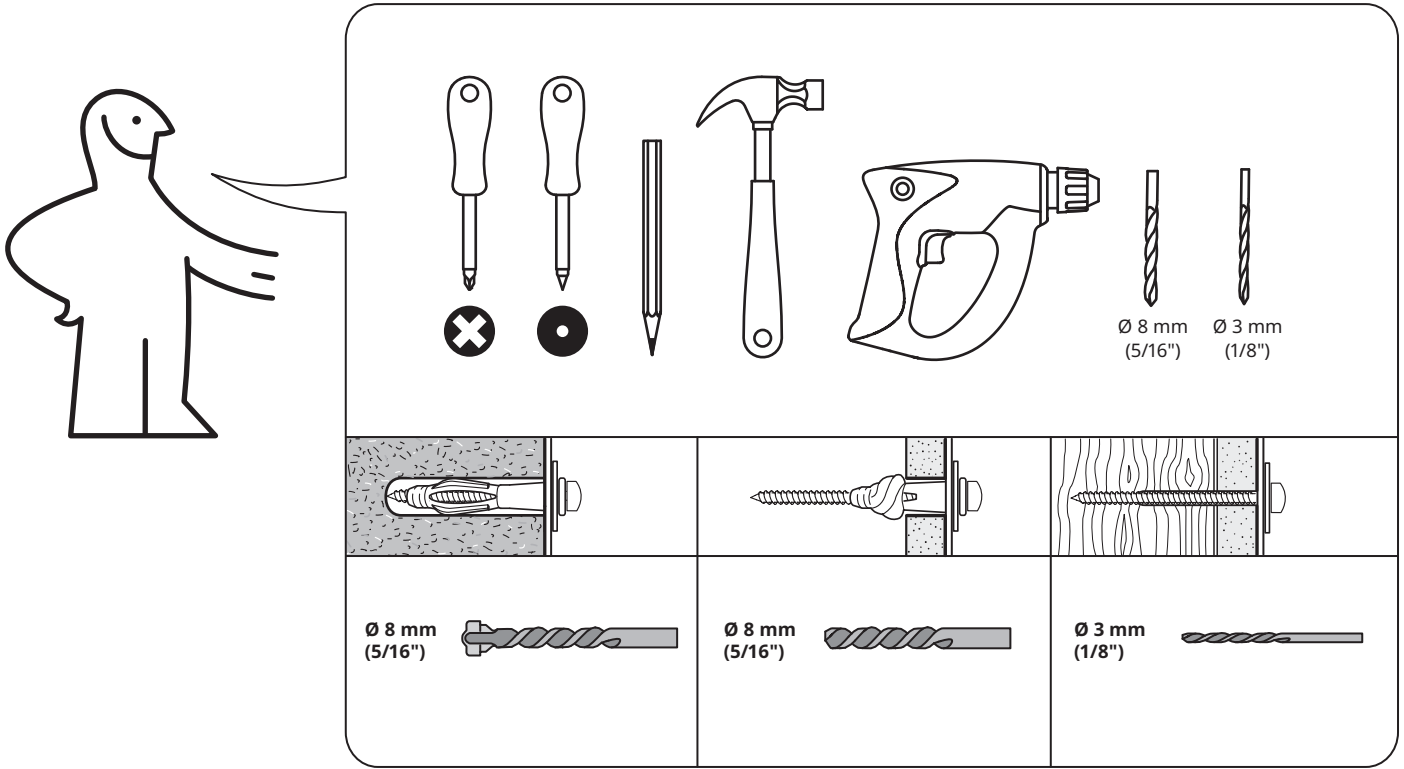

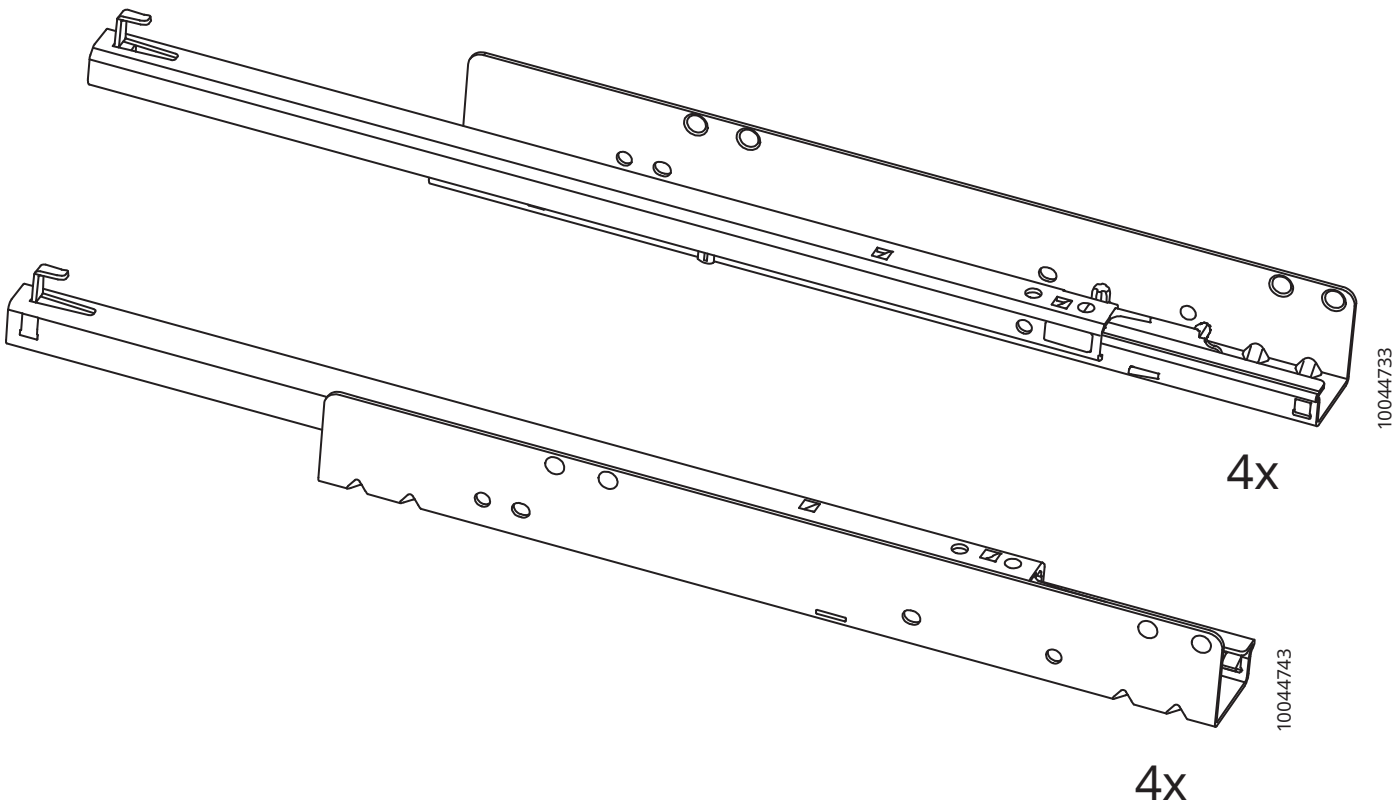
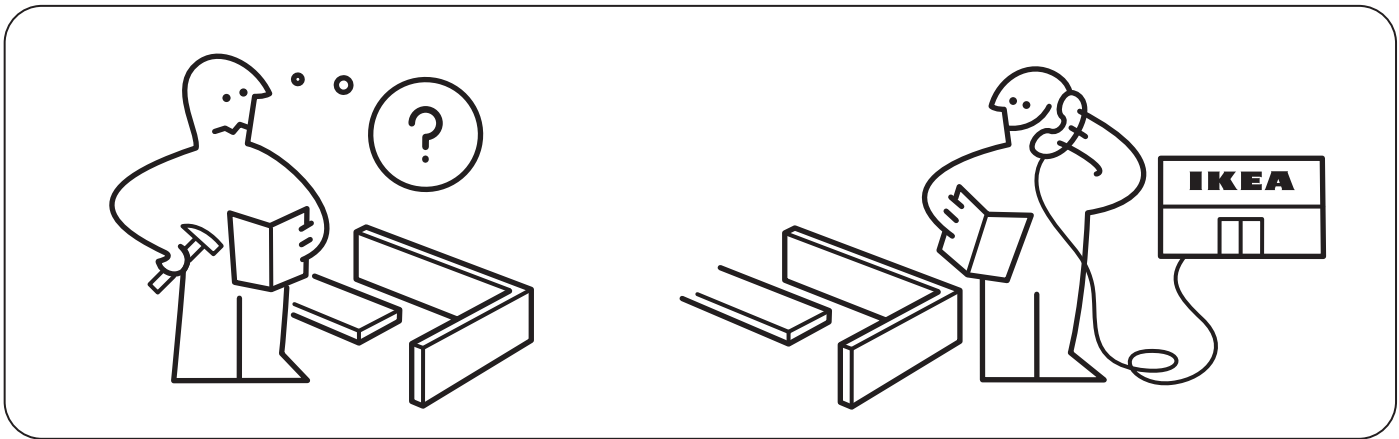
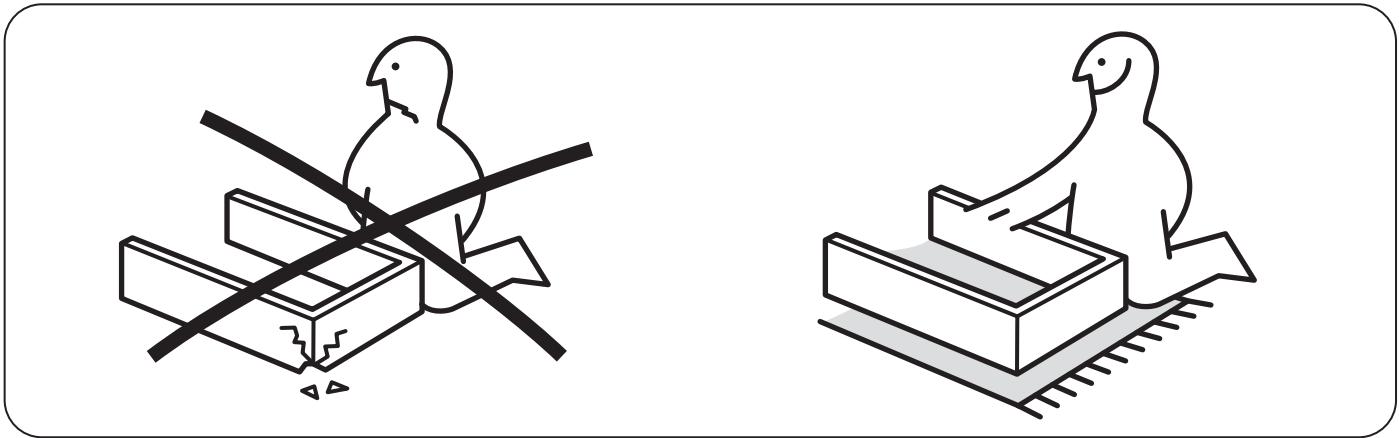

# 1



100347

16x



101345

12x

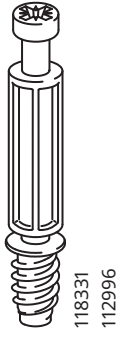

118331  
112996

12x



119253  
118137

12x



10

# 2

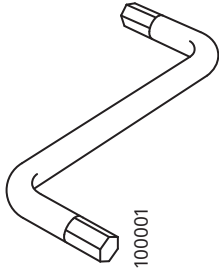

100001

1x



100347

4x



101352

4x

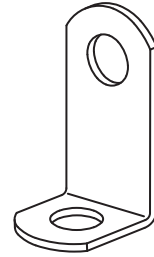

102553

2x

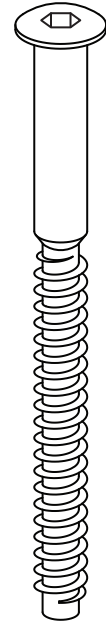

10093458

4x

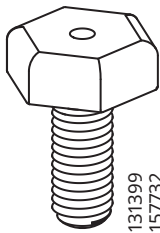

131399  
157732

4x

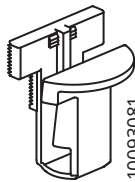

10093081

8x



10093082

8x

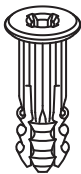

151706

4x

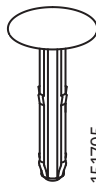

151705

4x



17



3



10041120

8x

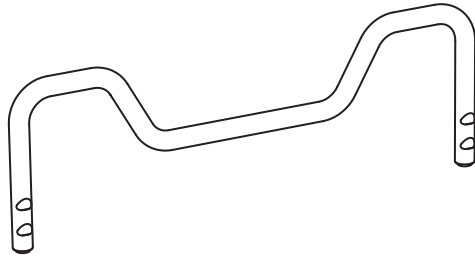

10047244

12x

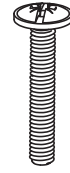

119976

8x

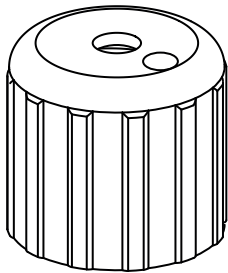
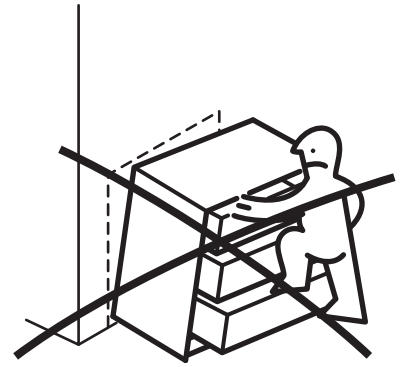
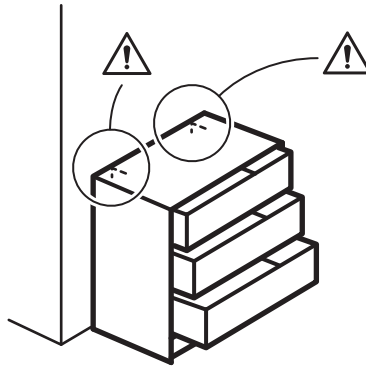
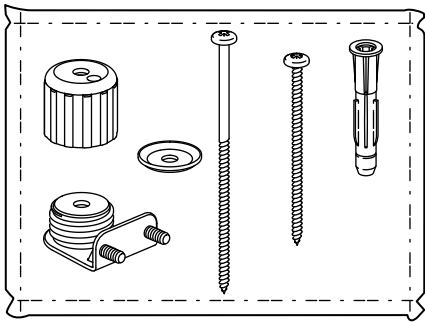
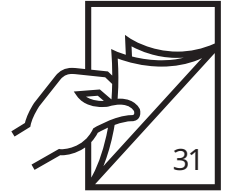

150689

2x

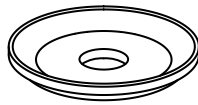

126916

2x

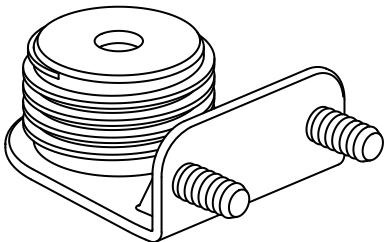

150688

2x

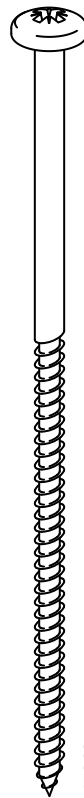

147968

2x

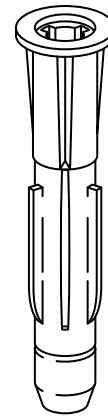

121714

2x

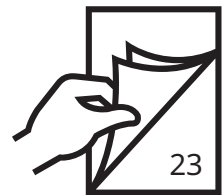

1

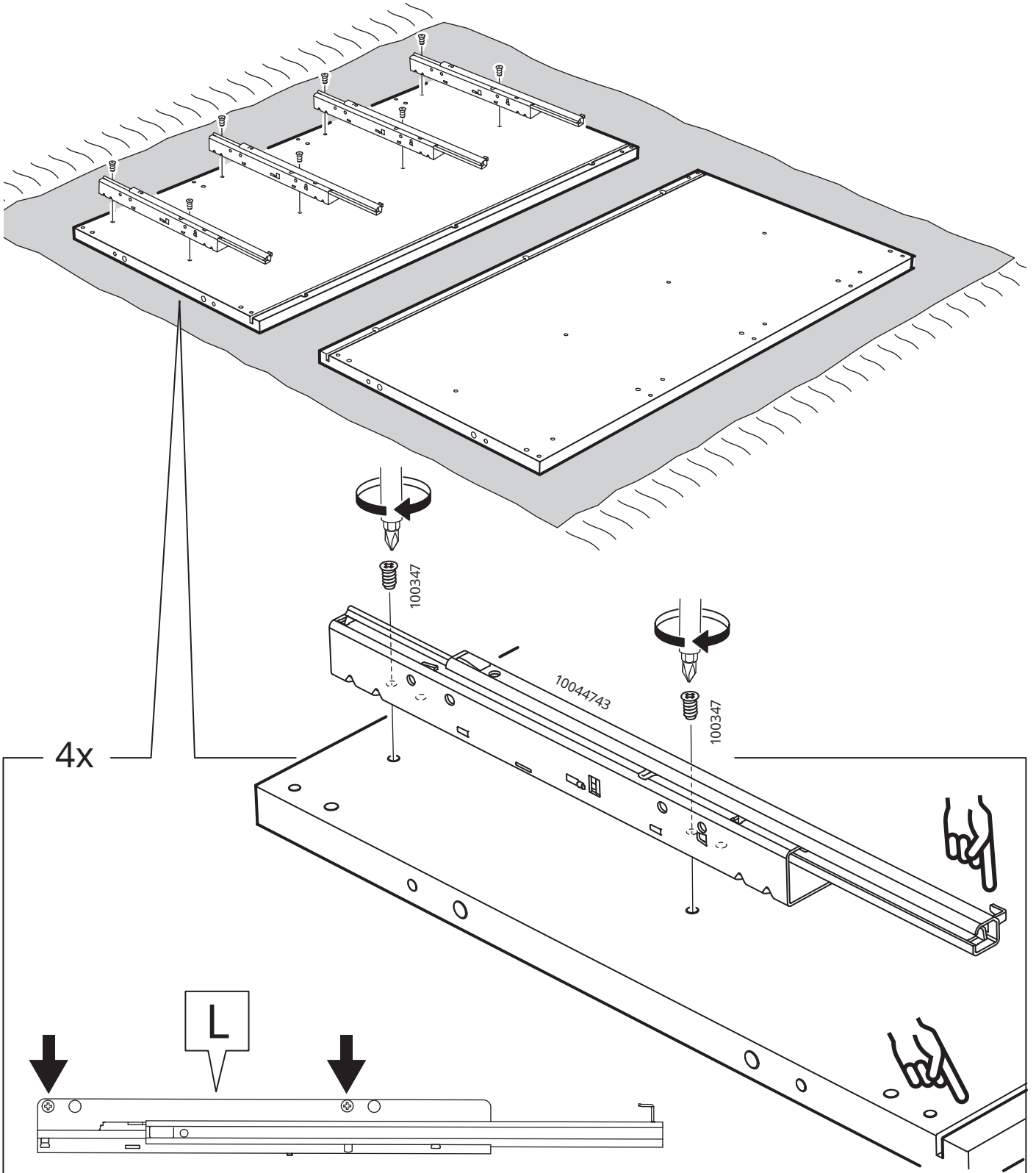
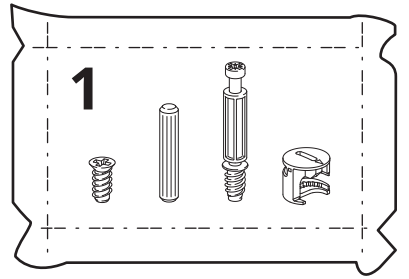

# 2

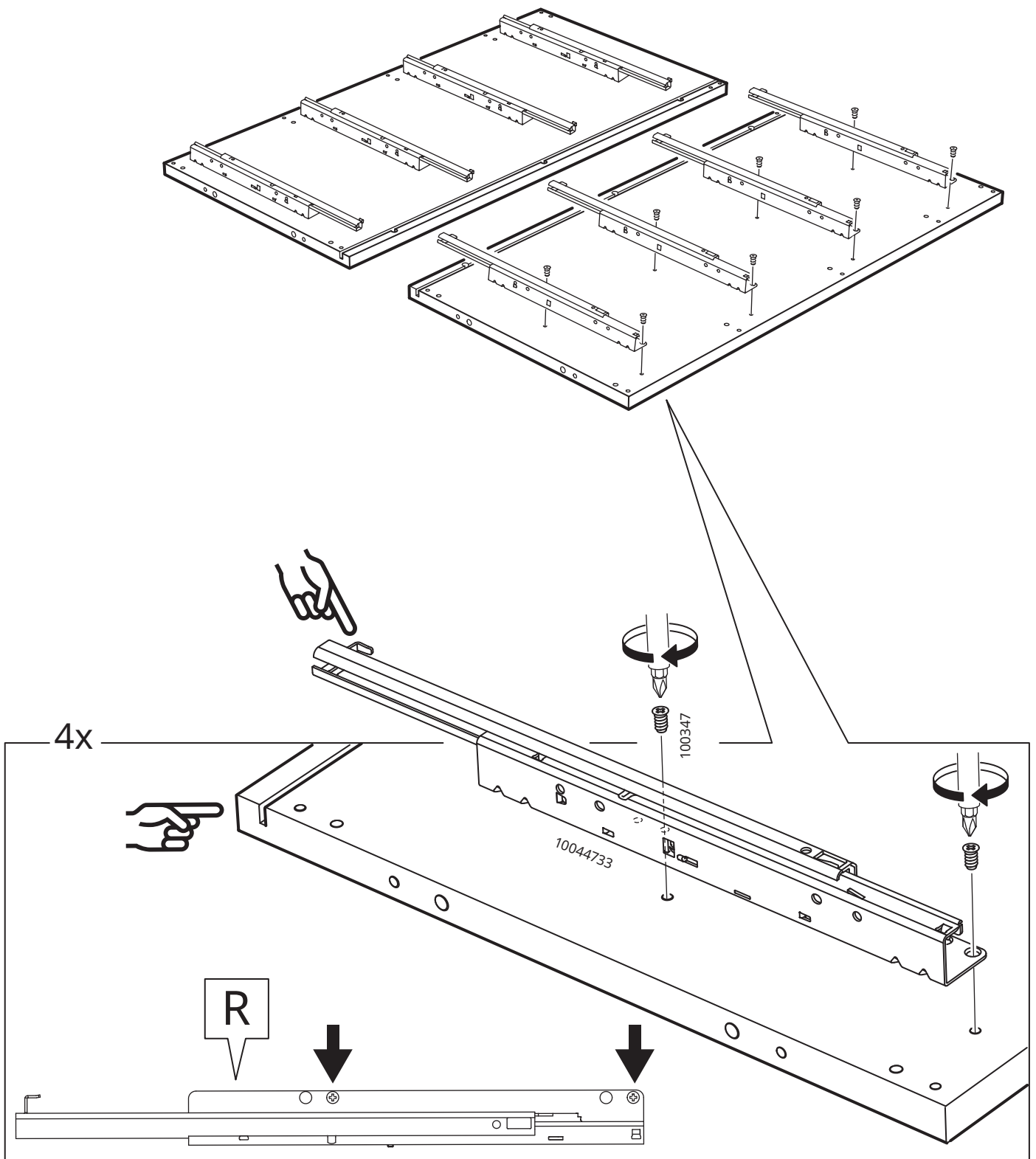

# 3

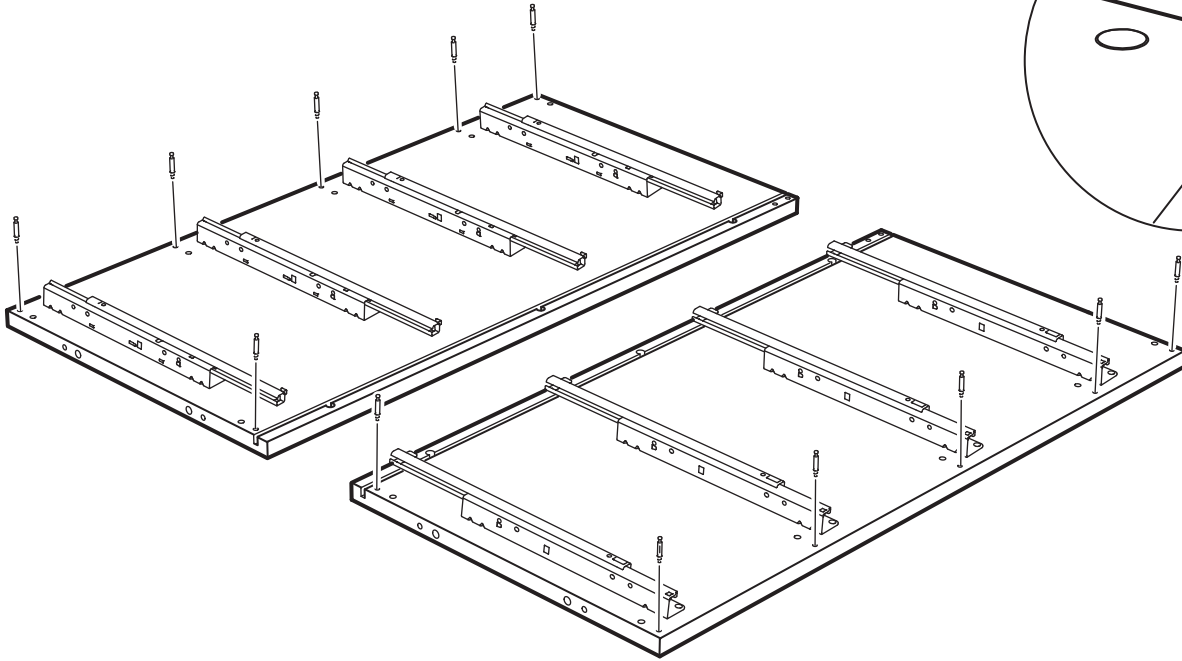
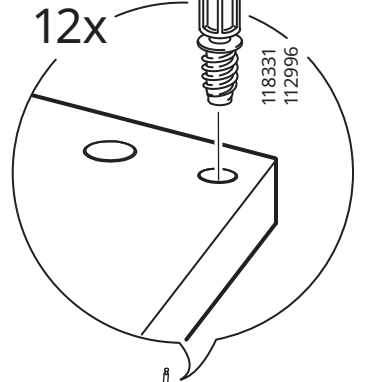
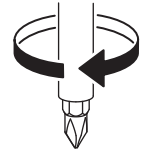
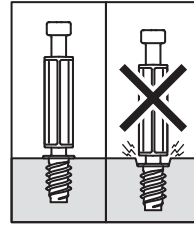

# 4

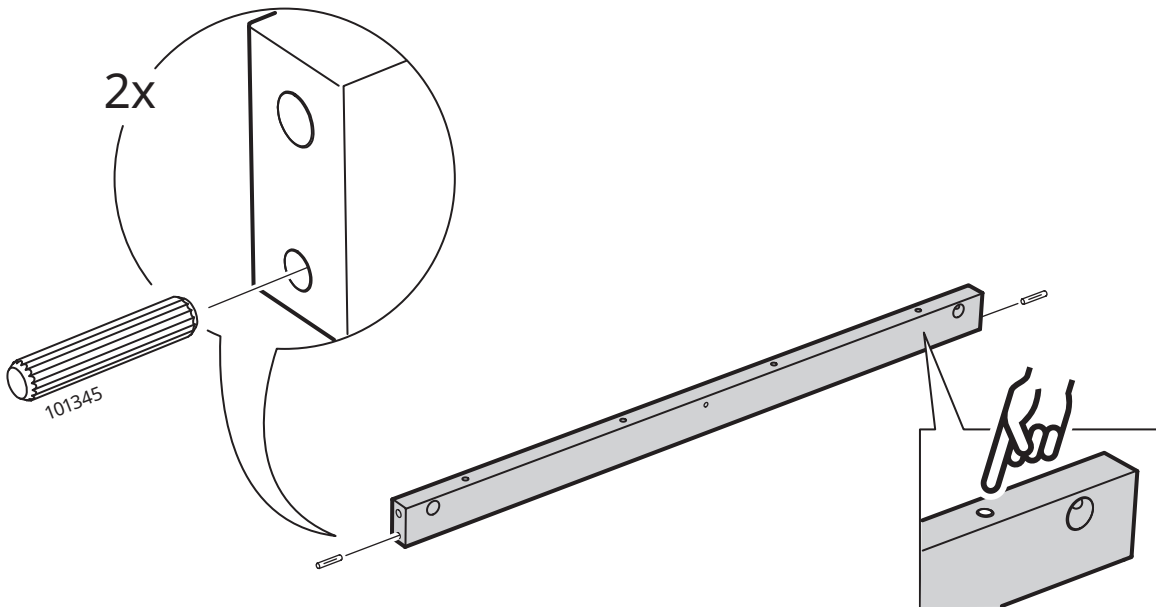

5

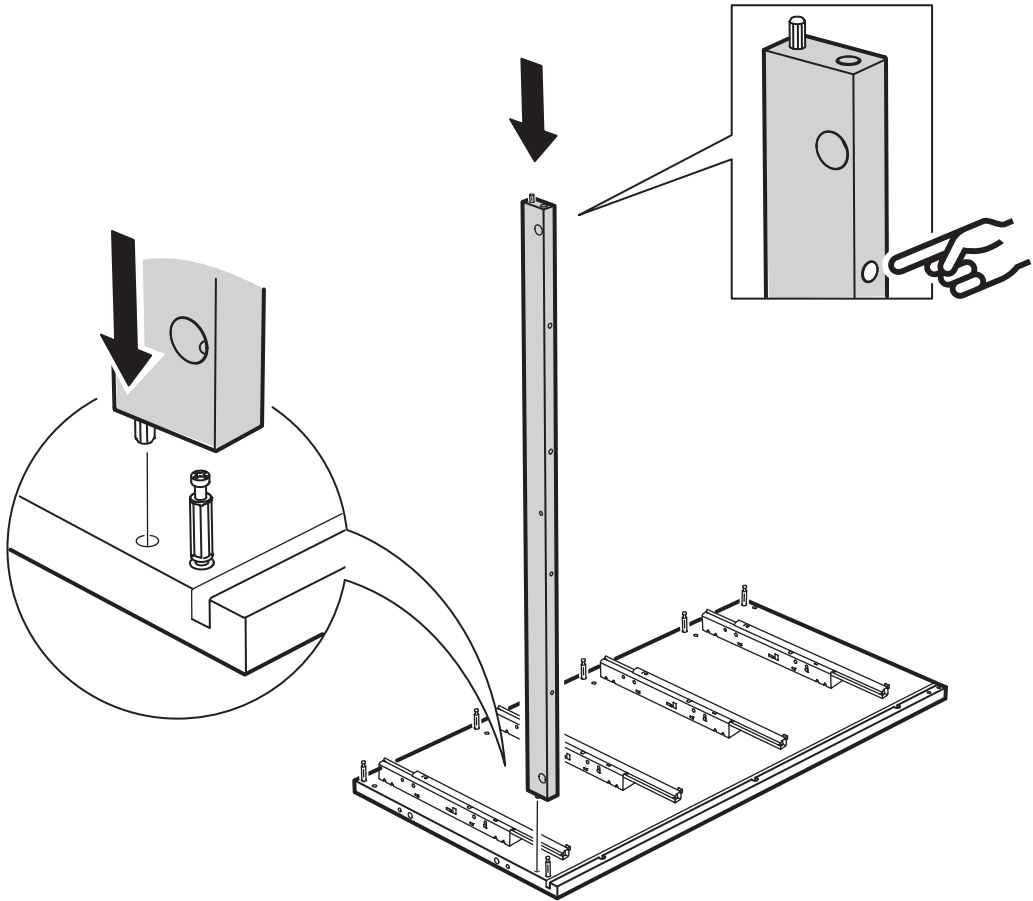

6

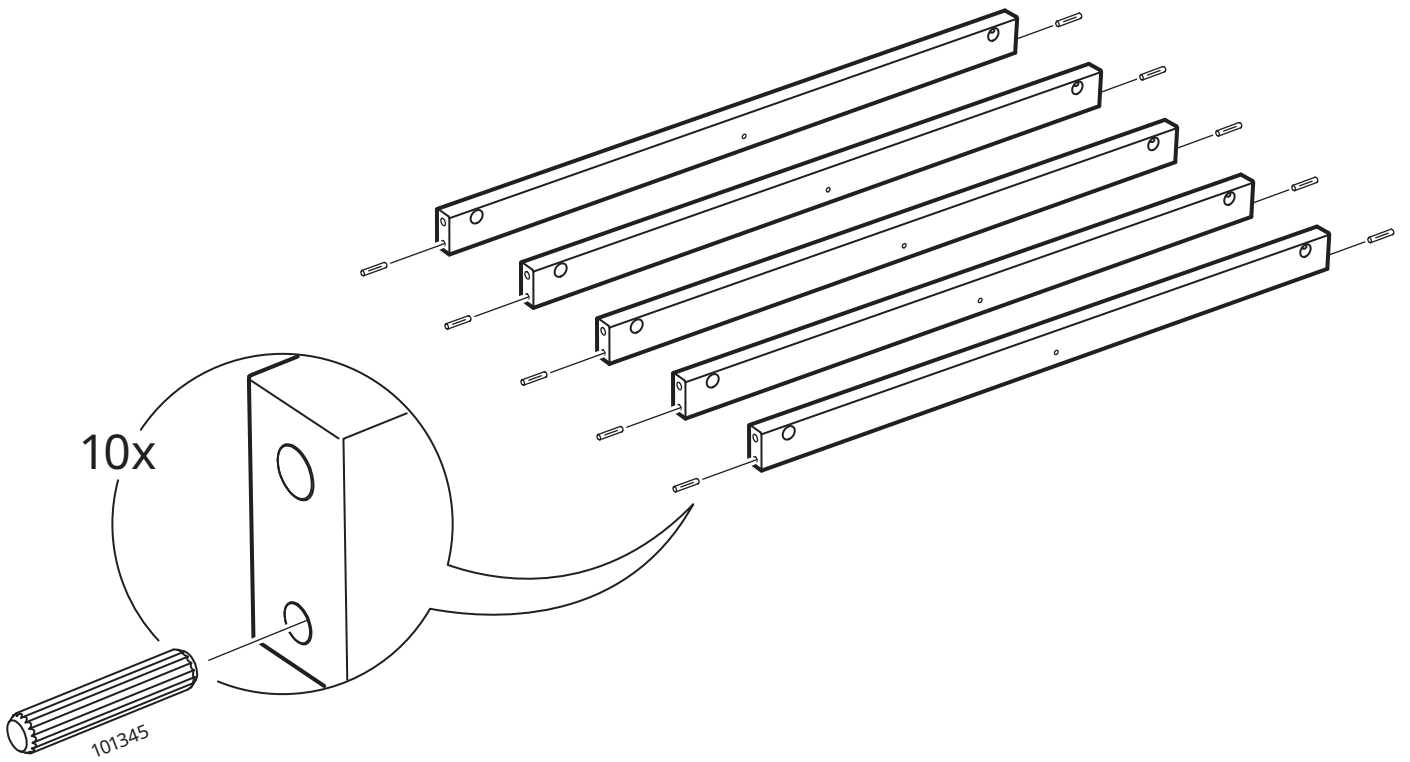

7

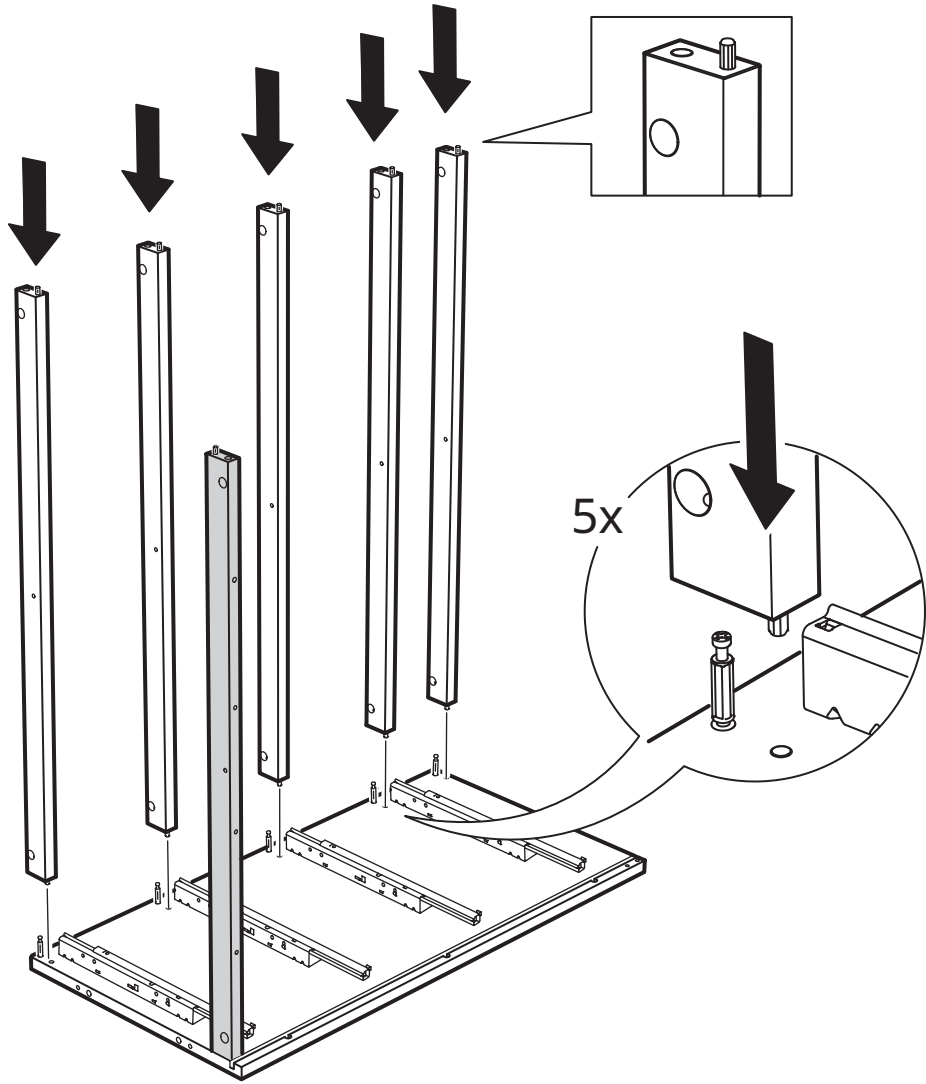

8

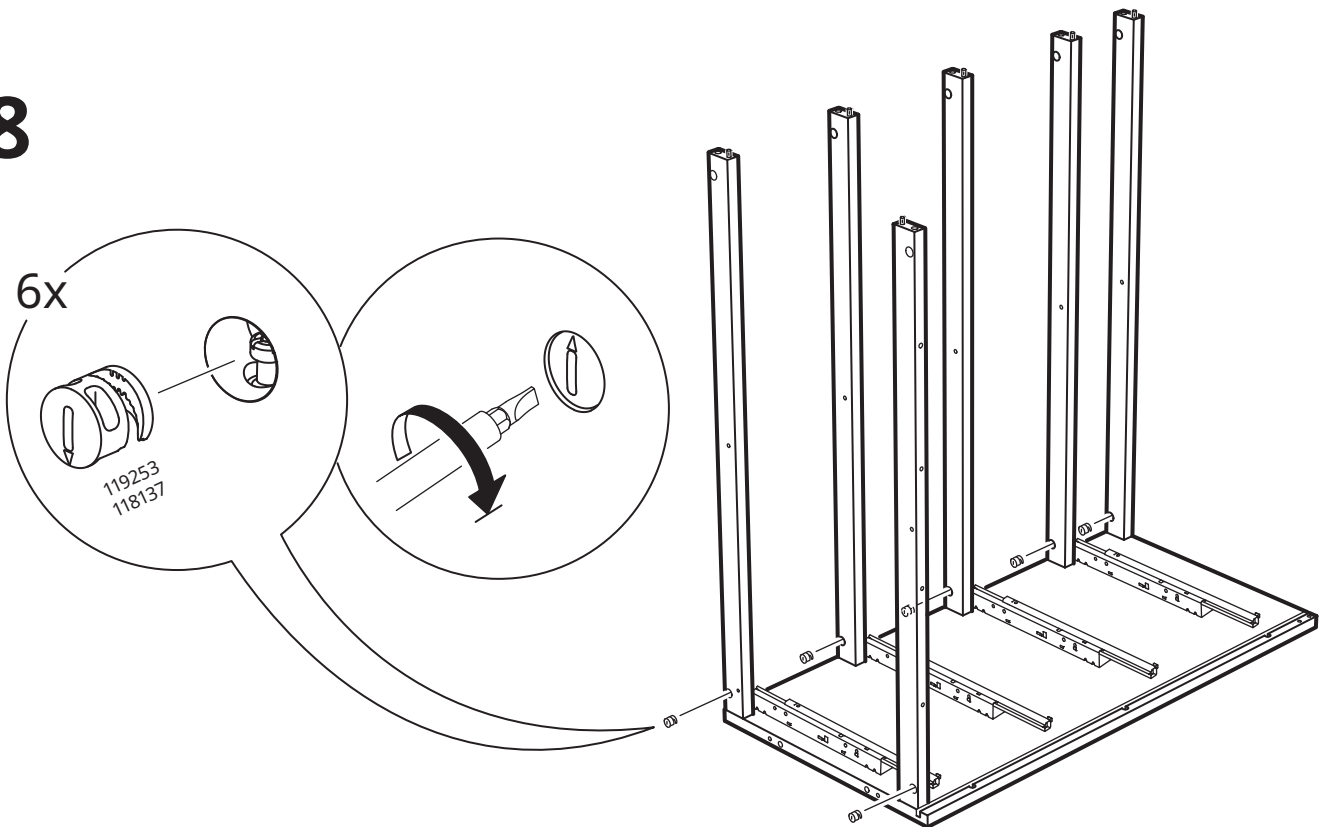

9

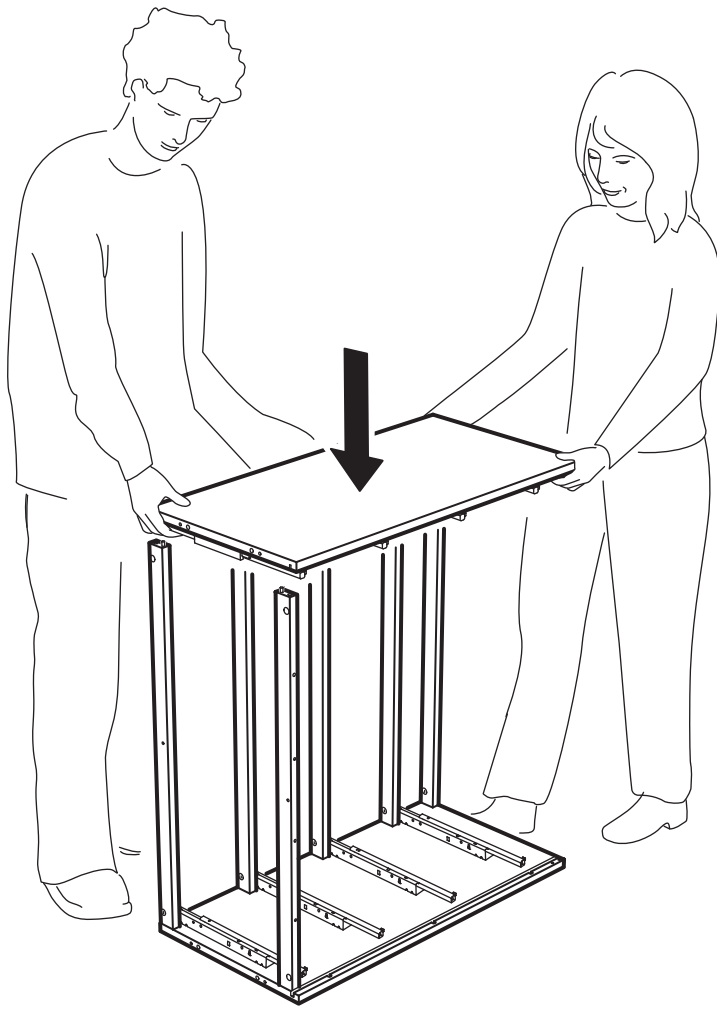

10

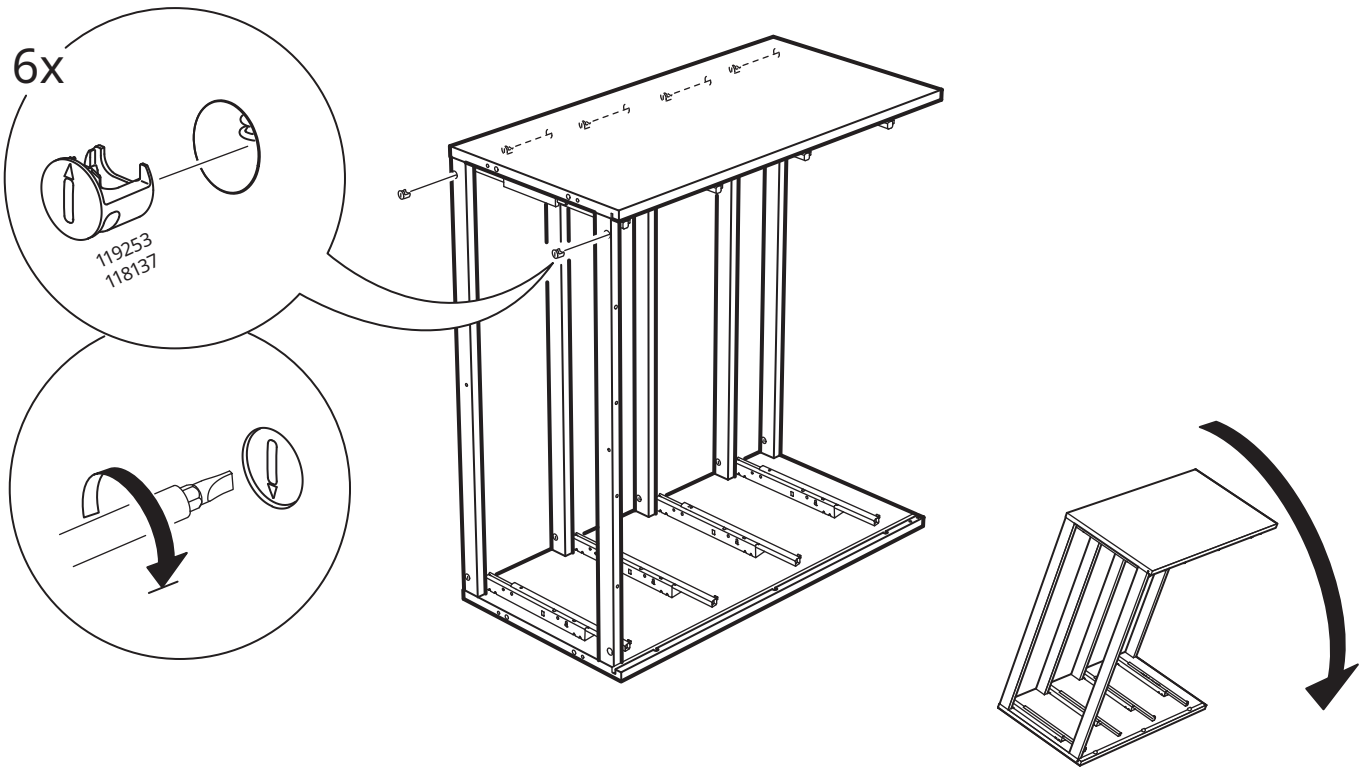

11

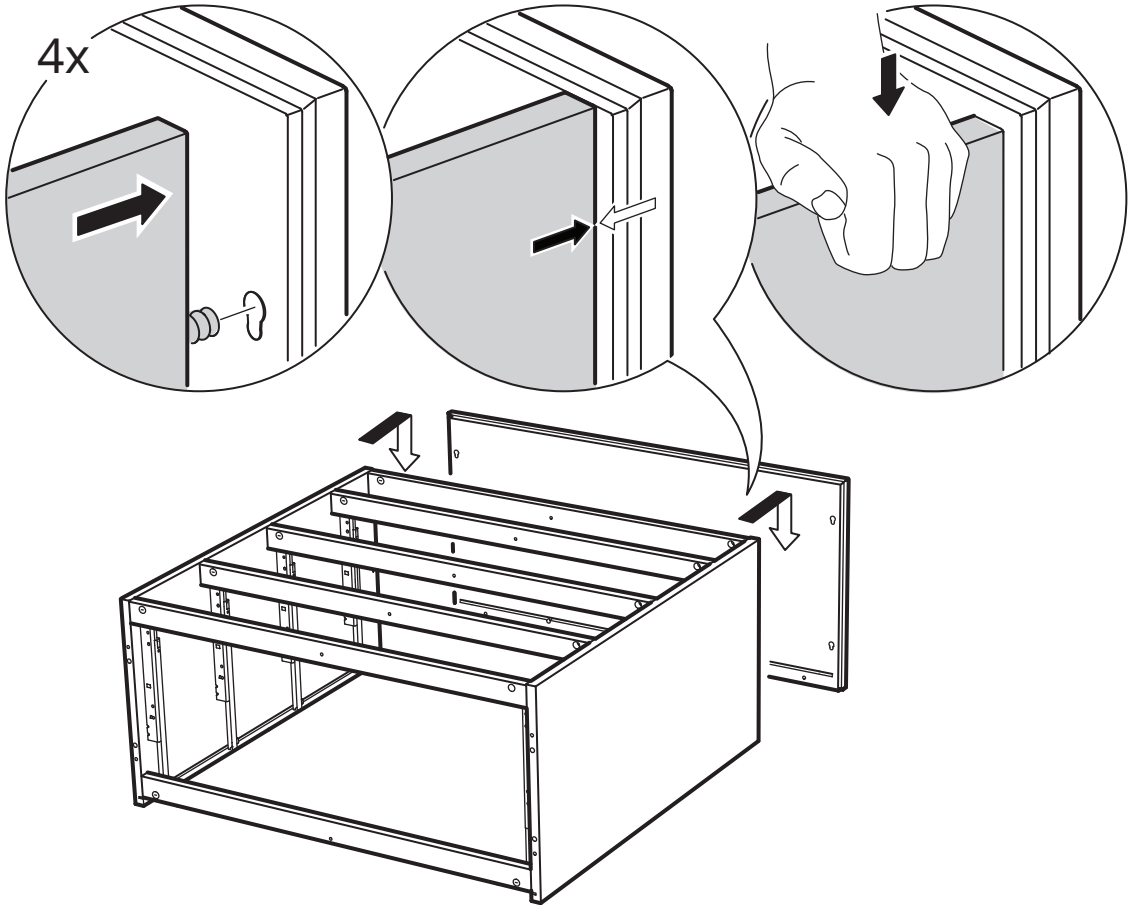

12

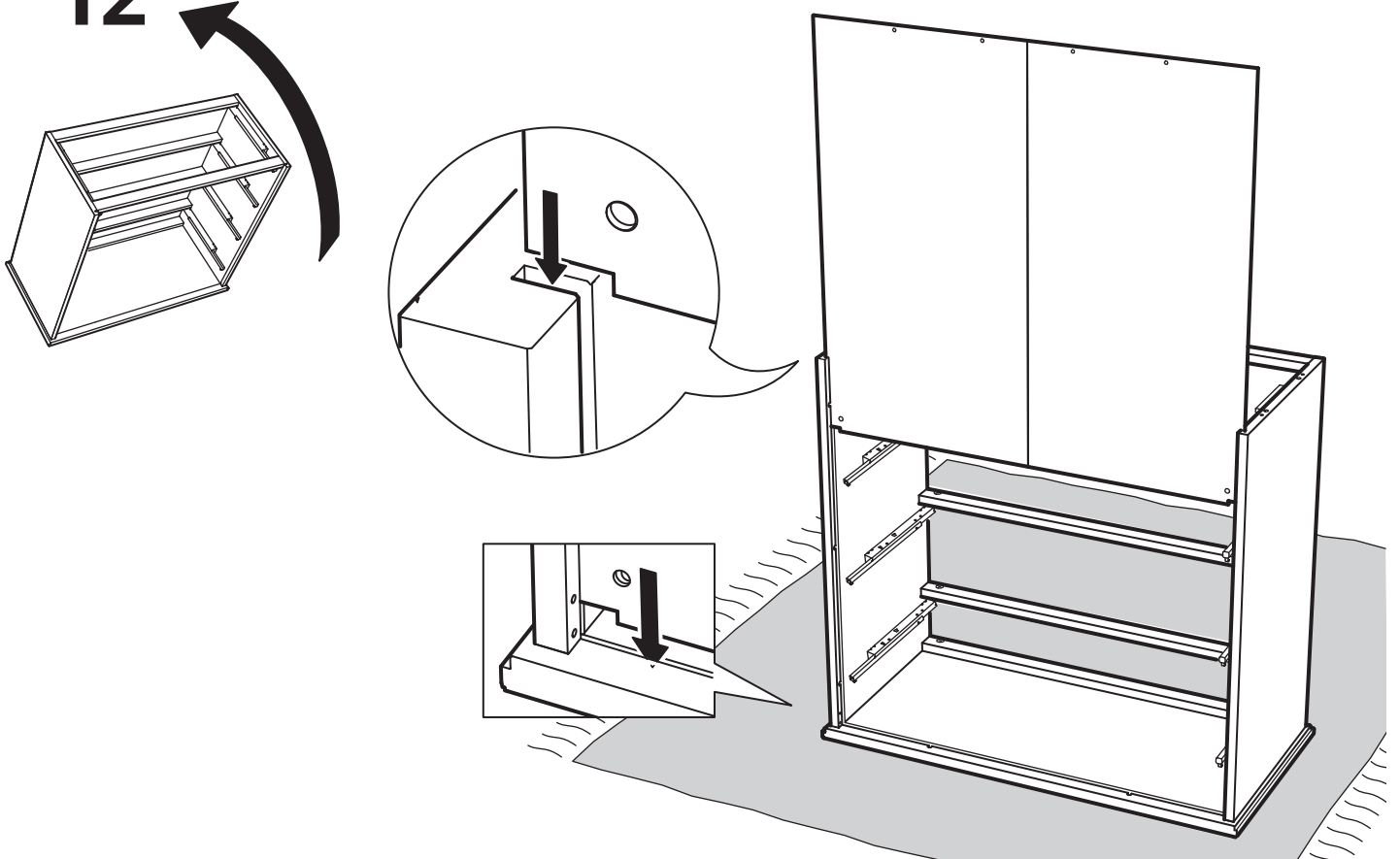



# 13

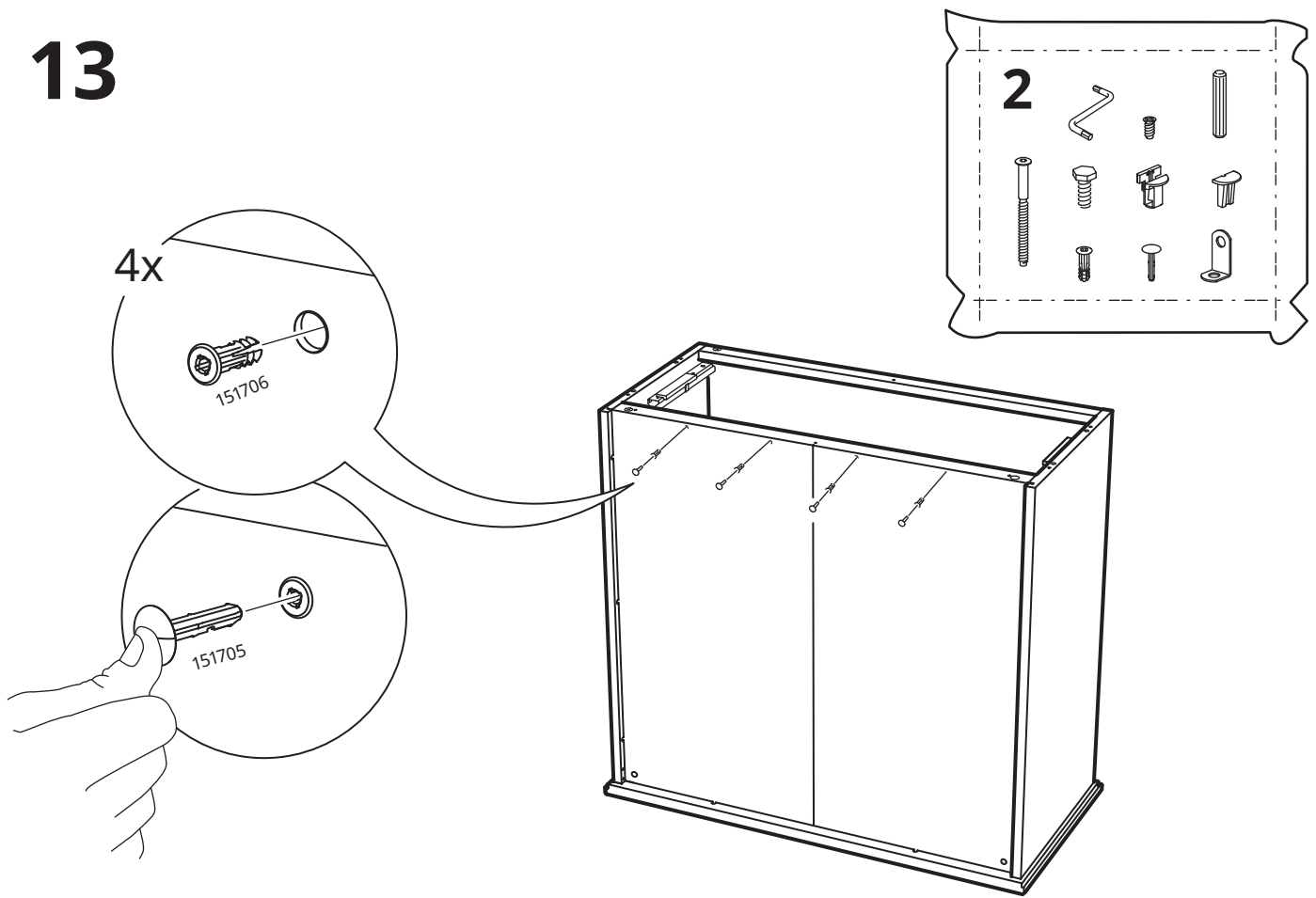

# 14

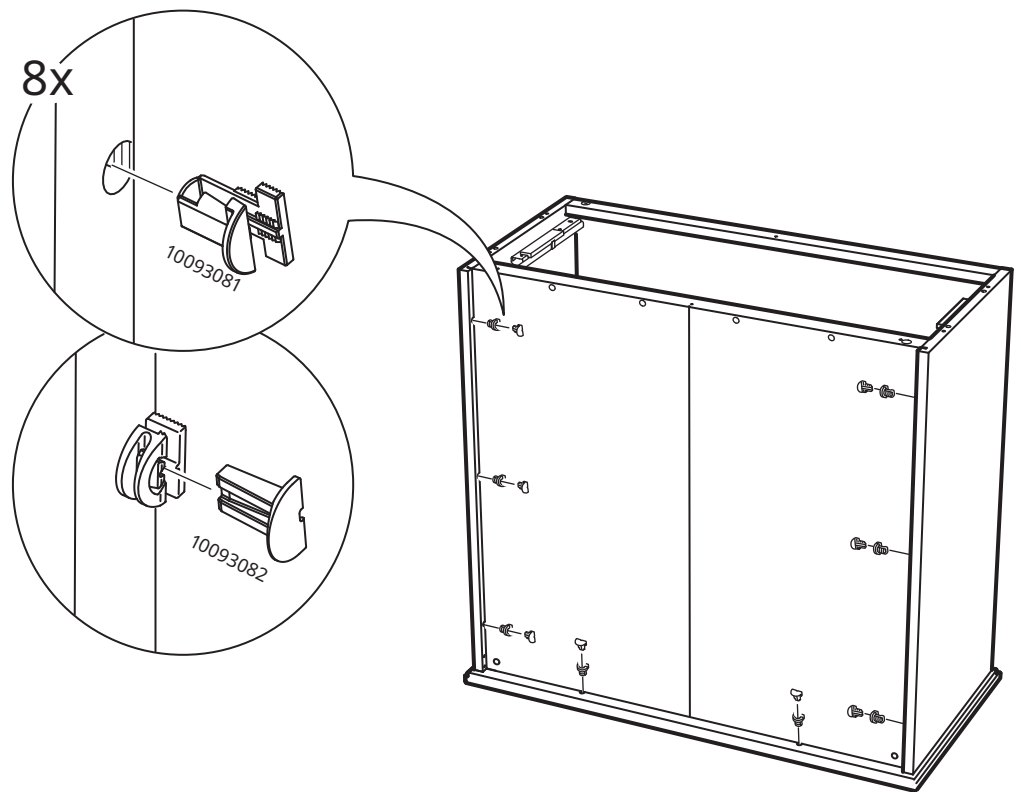

15

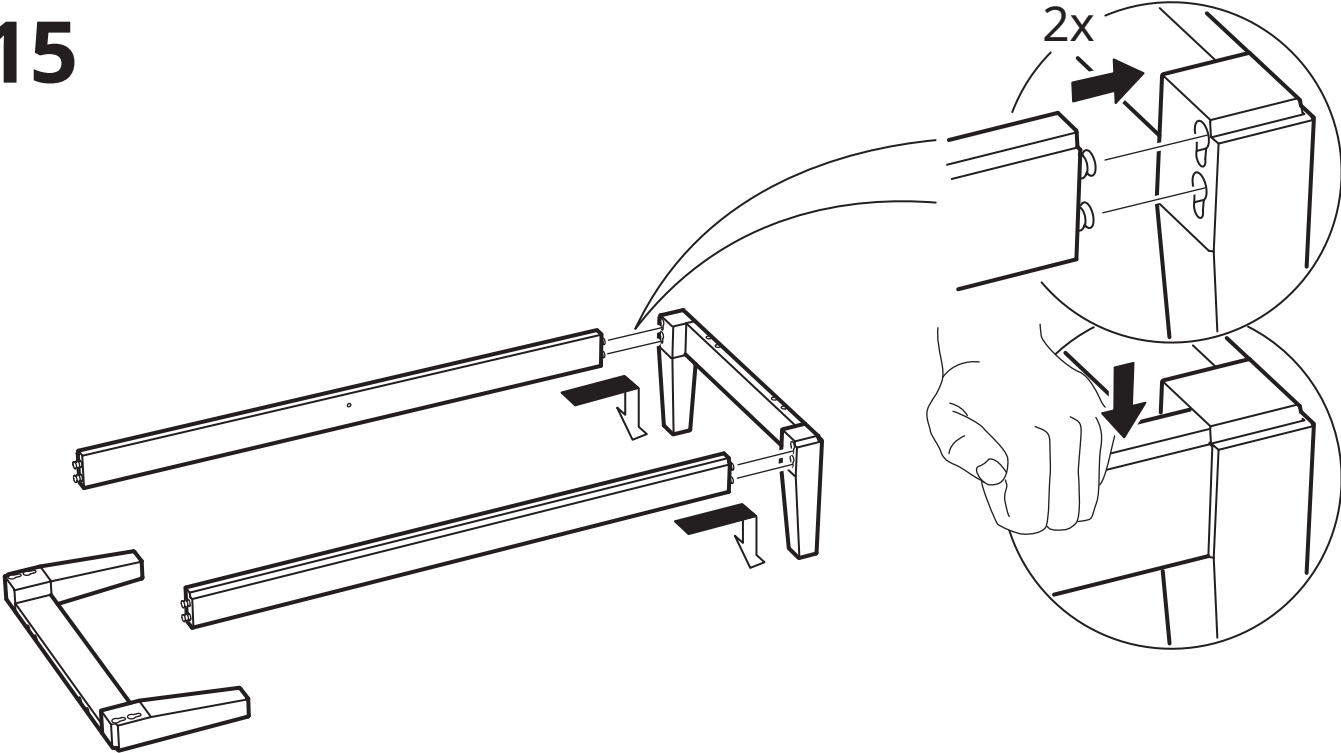

16

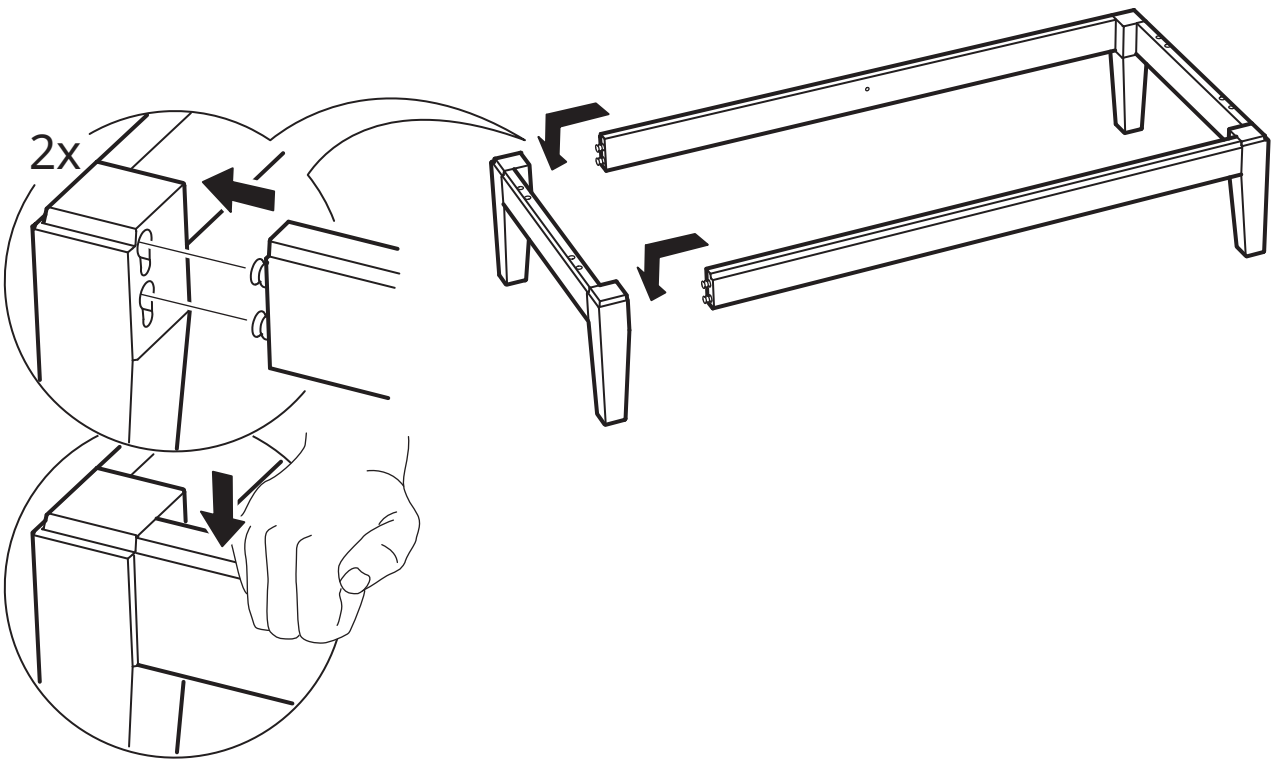

17

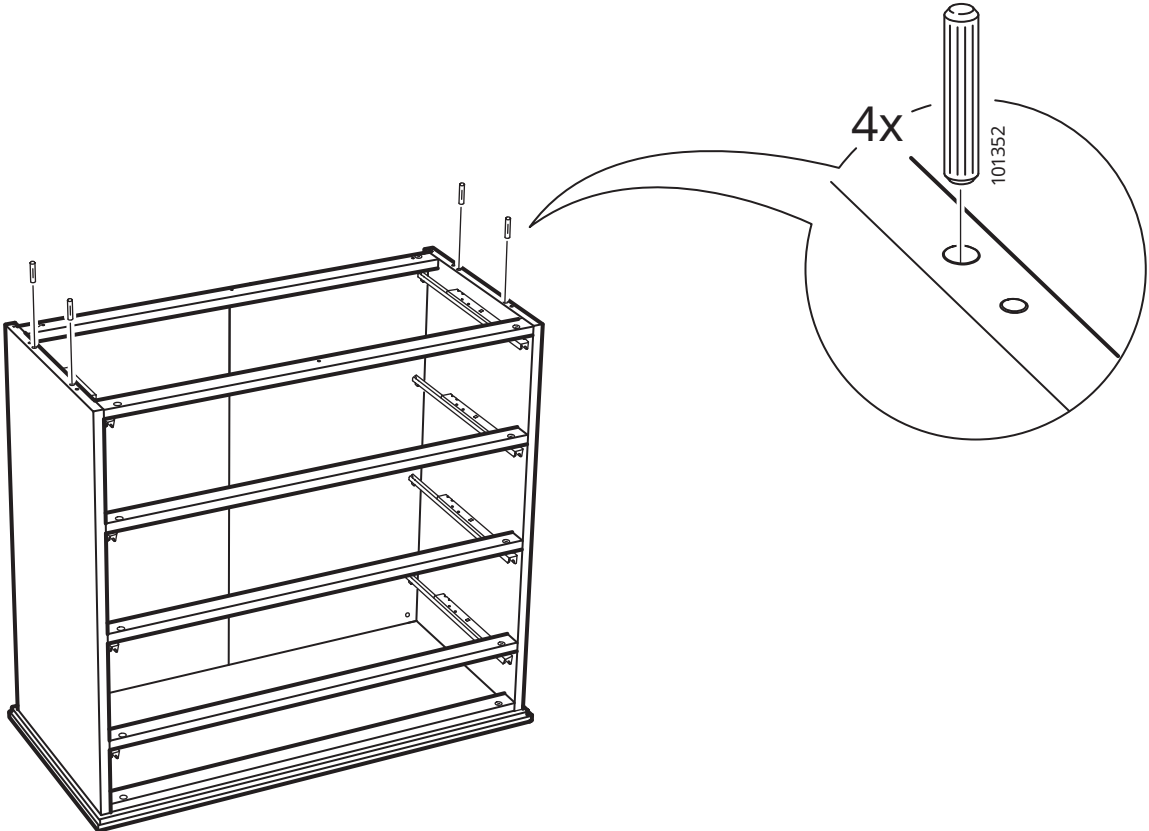

18

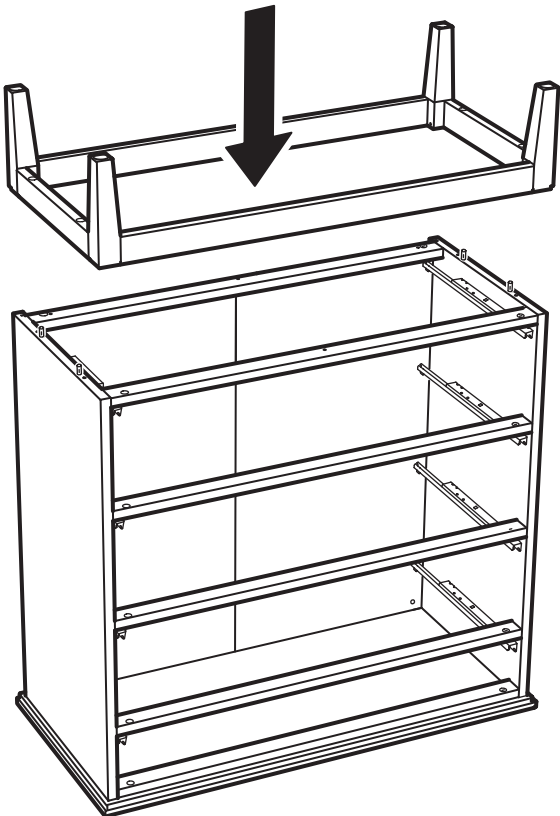

# 19

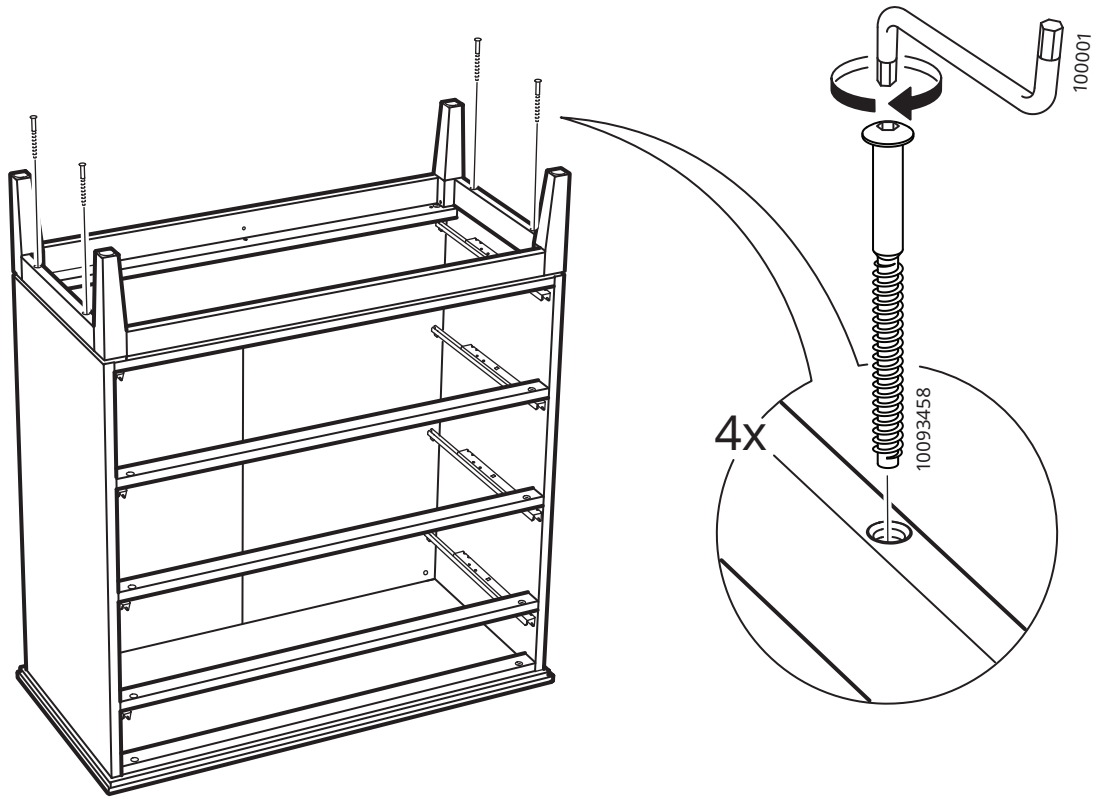

# 20

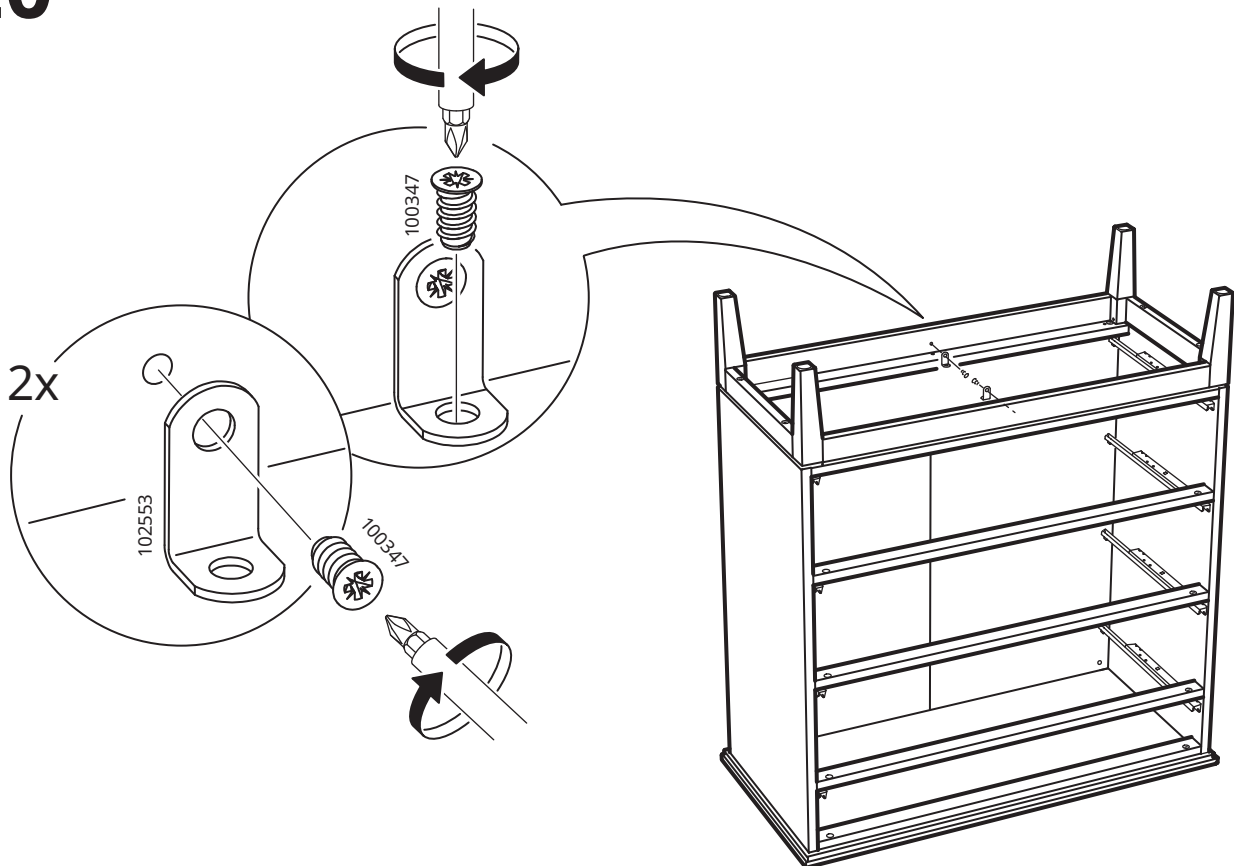

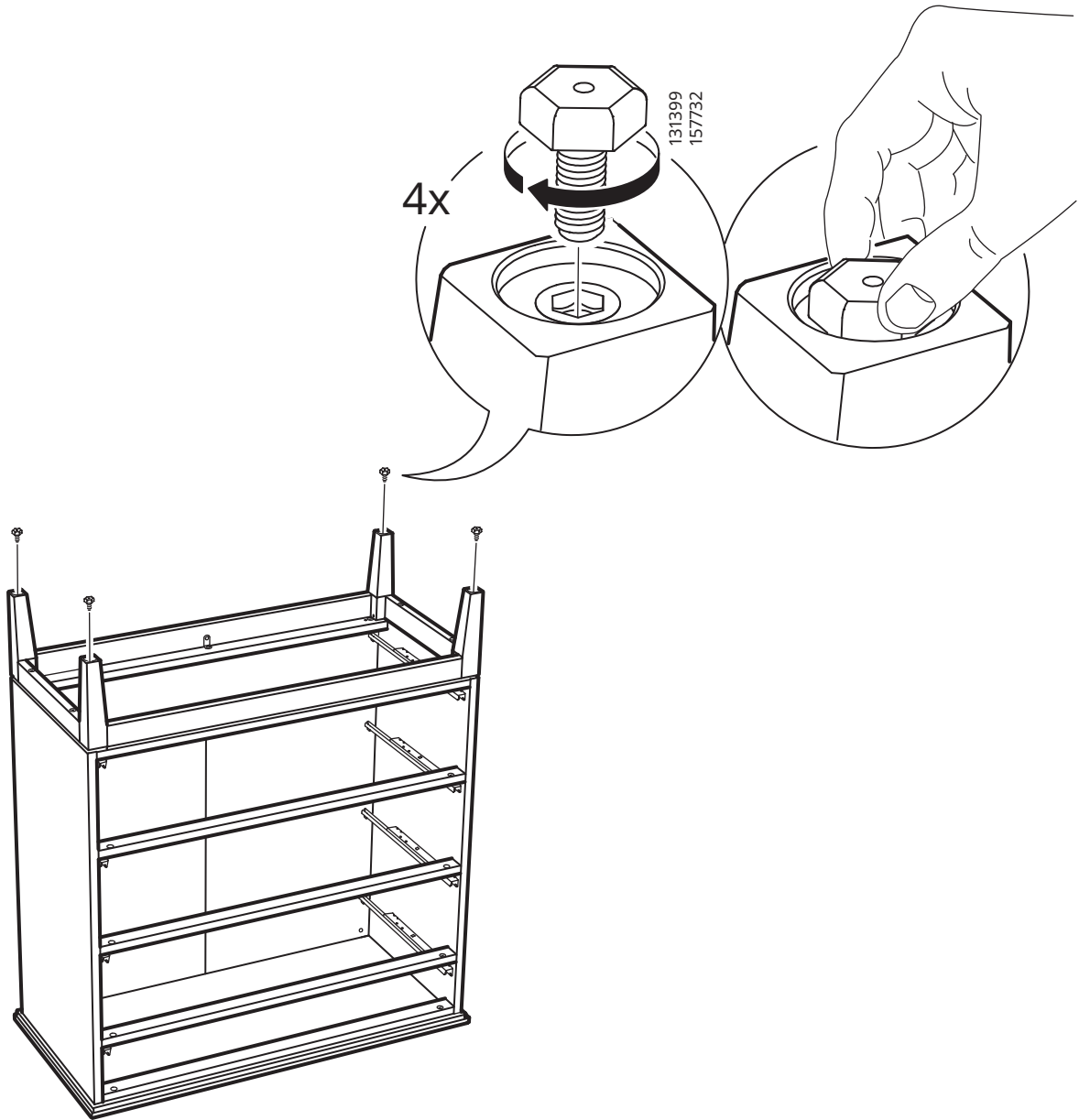

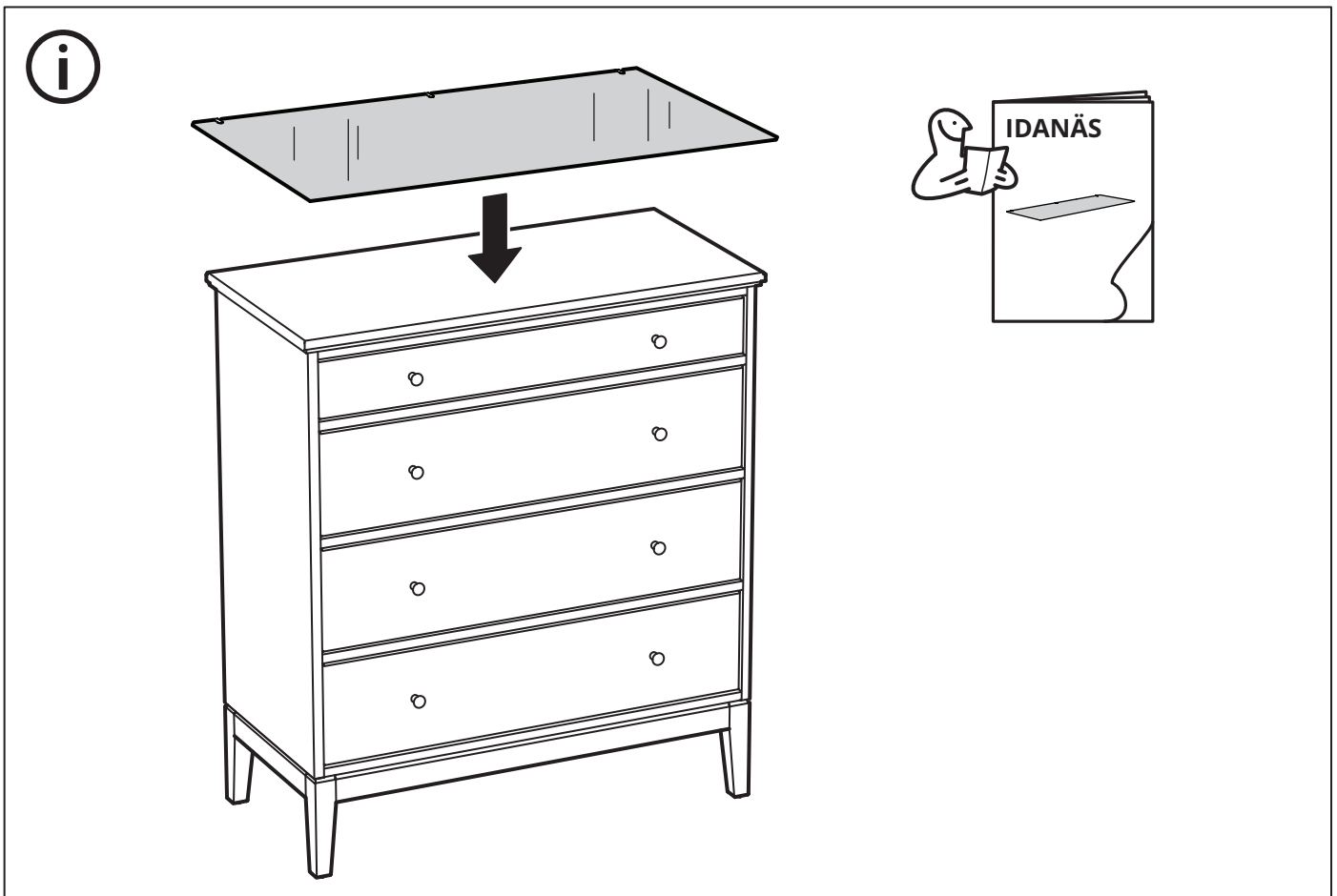
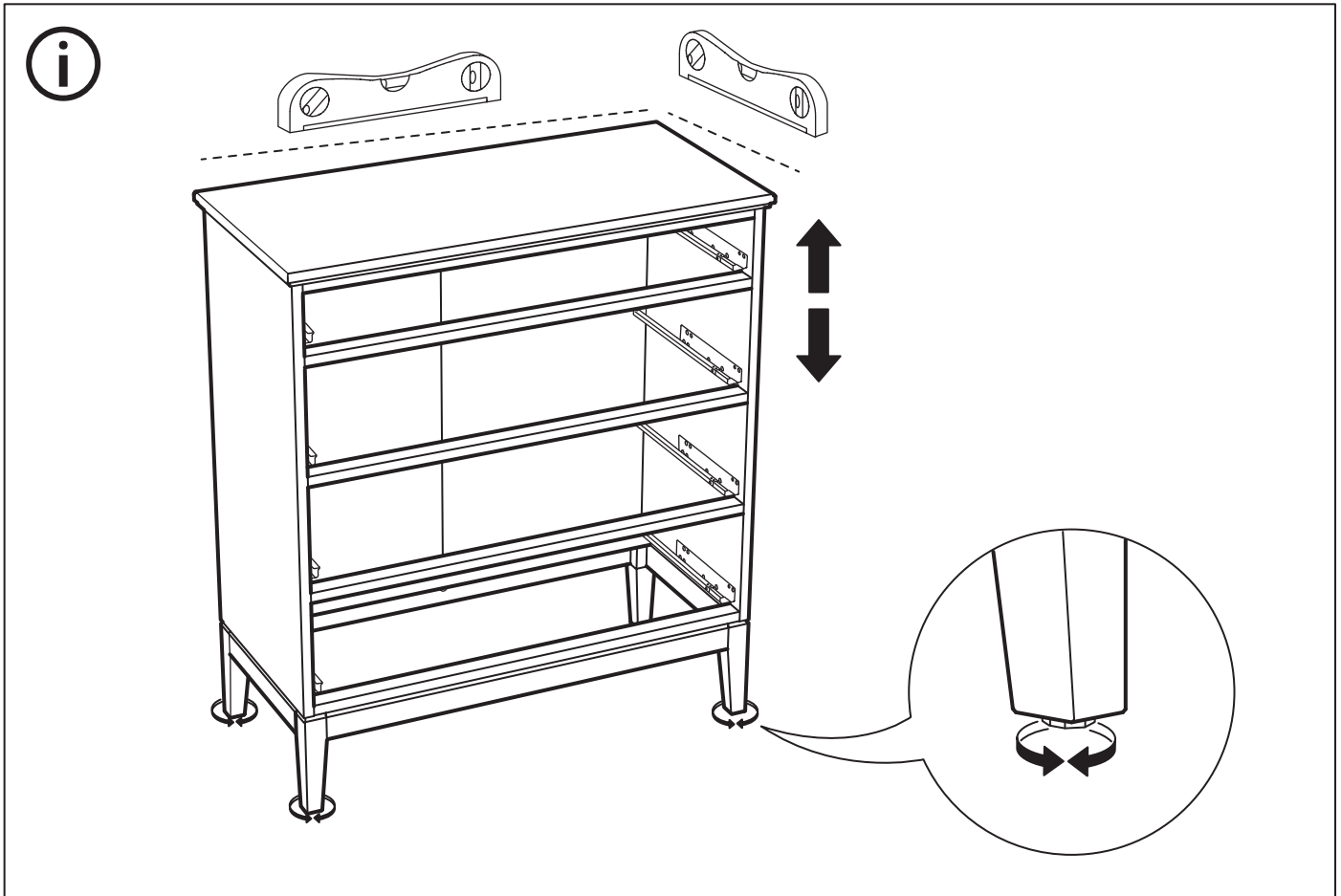

22

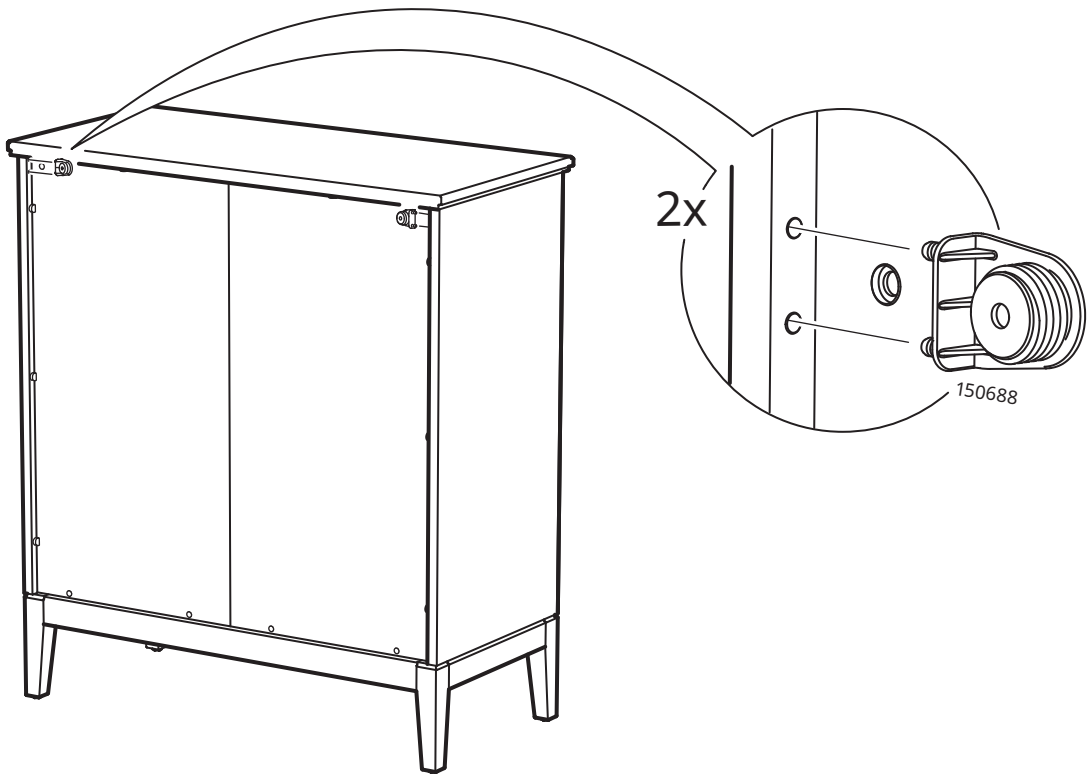
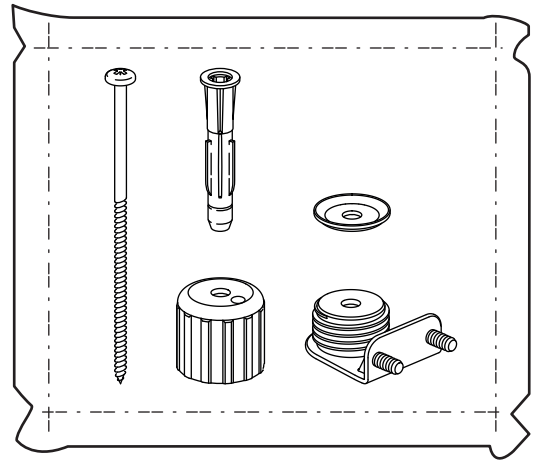

23

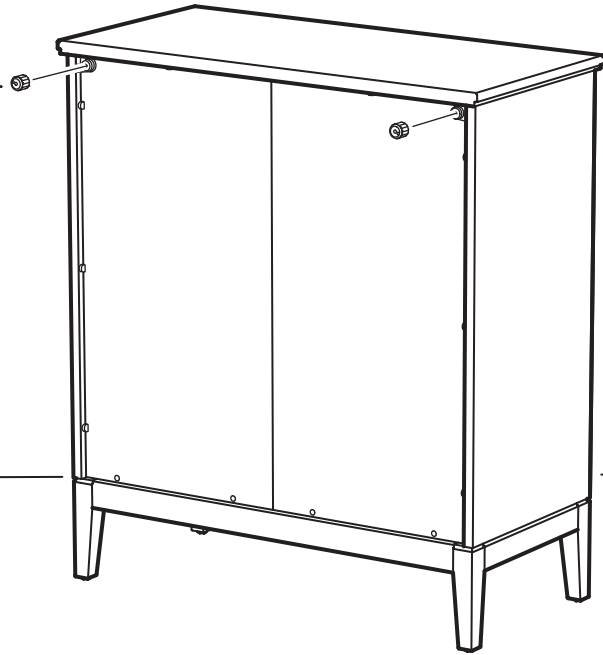
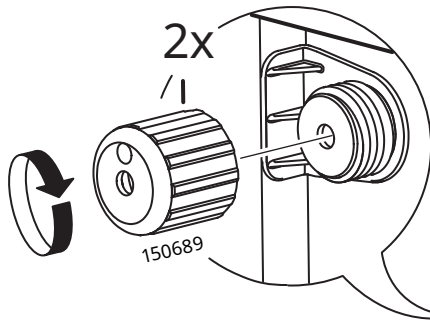

24

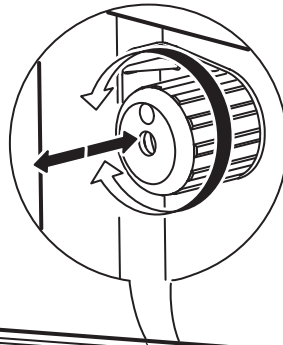
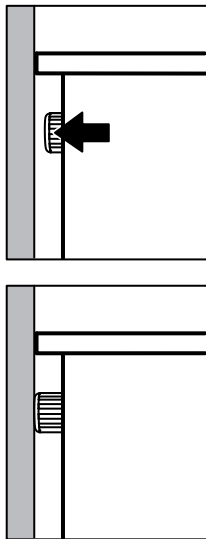



25

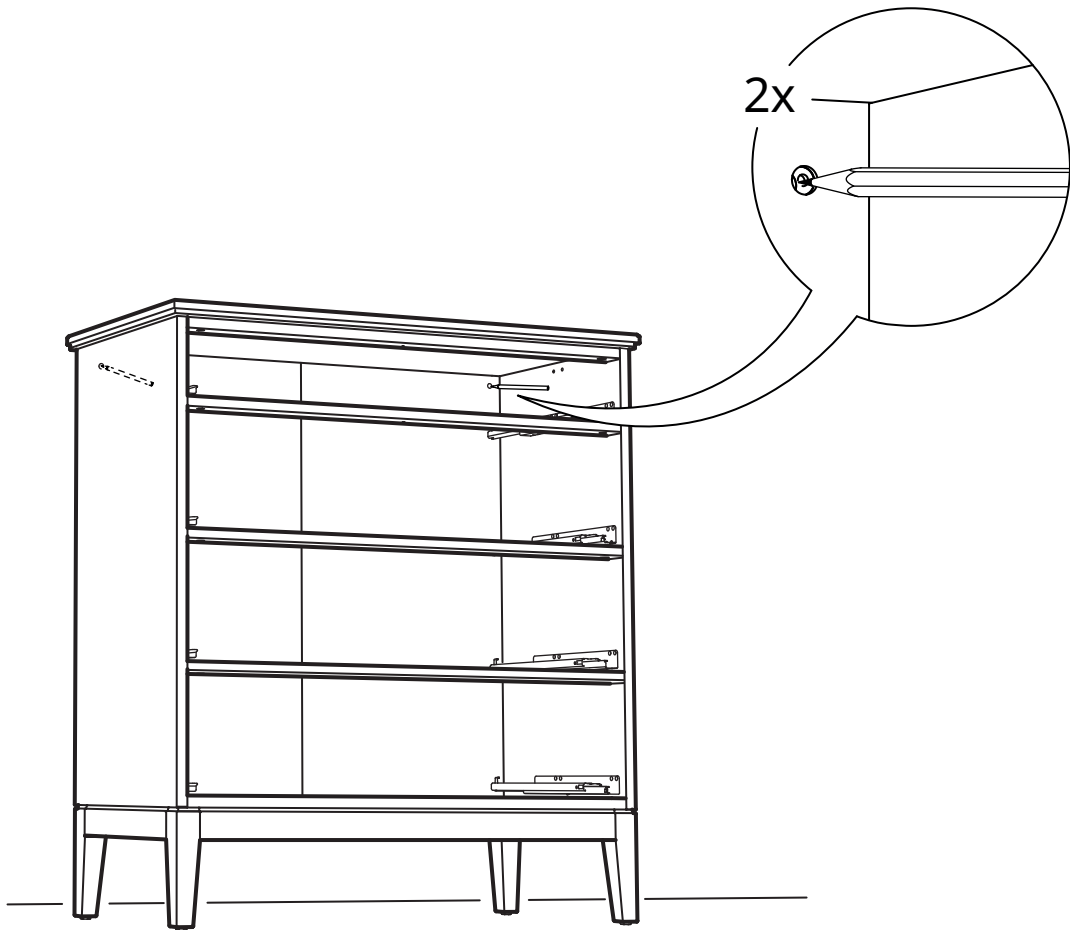

26

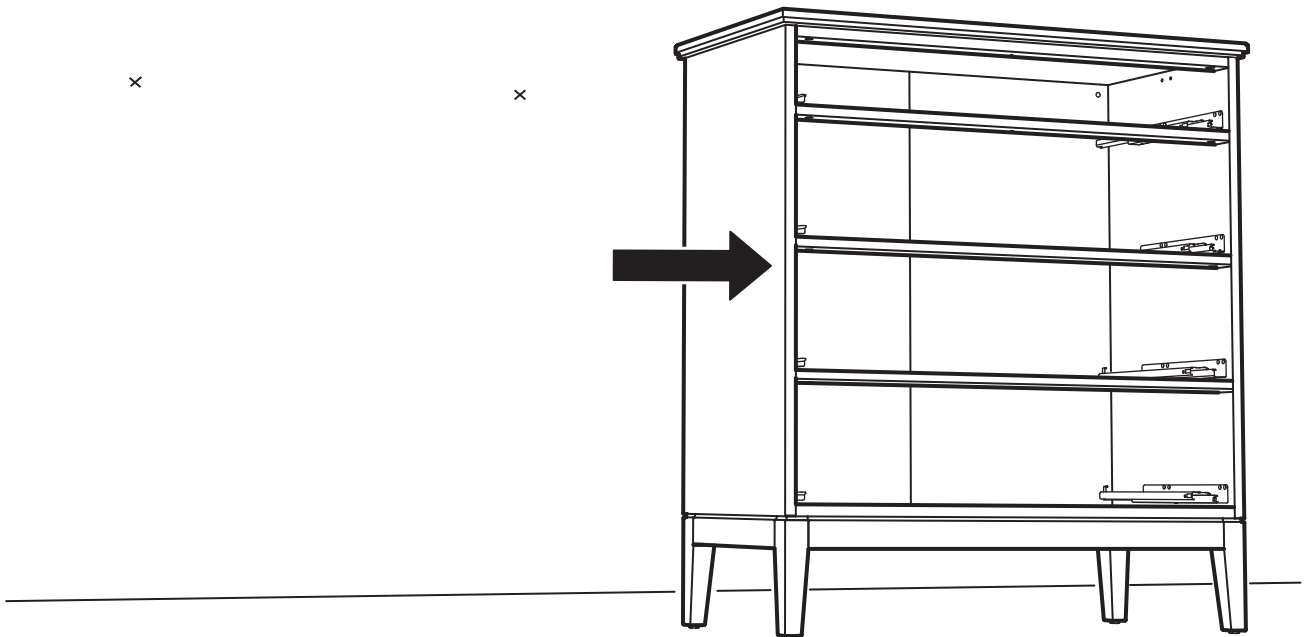

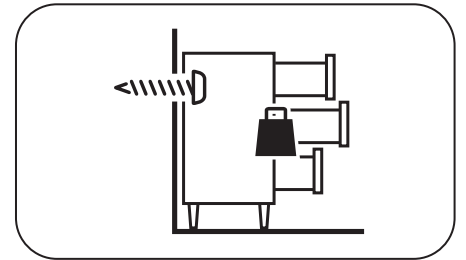

#### **Euskara**

Produktuak dakartzan torlojuak eta takoak horma solido (A) eta huts (B) gehienetan erabili ahal dira. Egur trinkoen (C) kasuan, ez erabili takoak torlojuekin. Zalantzarik baduzu, galdetu aditu bati.

#### **Català**

Els cargols i els tacs inclosos es poden fer servir a la majoria de les parets sòlides (A) o buides (B). Per a la fusta massissa (C), fes servir els cargols sense tacs. Si tens cap dubte, consulta un expert.

#### **Galego**

Os parafusos e tacos incluídos pódense utilizar na maior parte das paredes sólidas (A) ou ocas (B). Para a madeira maciza (C), emprega os parafusos sen tacos. Se tes dúbidas, acude a un experto.

#### **Español**

Los tornillos y tacos incluidos se pueden utilizar en la mayor parte de las paredes sólidas (A) o huecas (B). Para la madera maciza (C), usa los tornillos sin tacos. Si tienes dudas, acude a un experto.

**A**

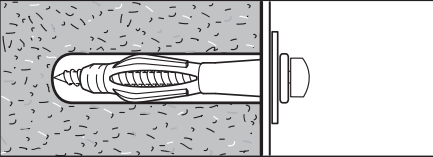

**Ø 8 mm (5/16")** 

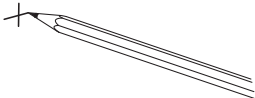
**1** 

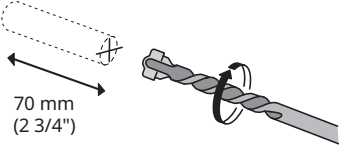
**2**  70 mm (2 3/4")

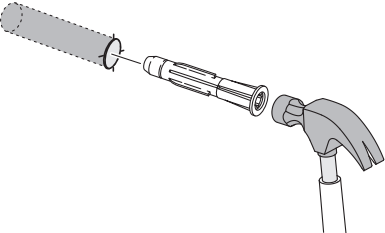
**3** 

**B**

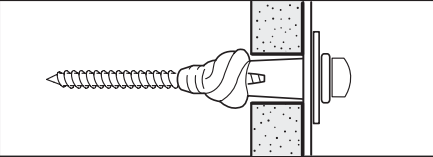

**Ø 8 mm (5/16")** 

**1** 

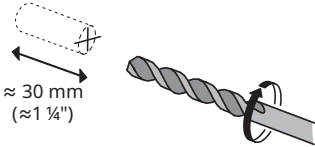
**2**  ≈ 30 mm (≈ 1 1/4")

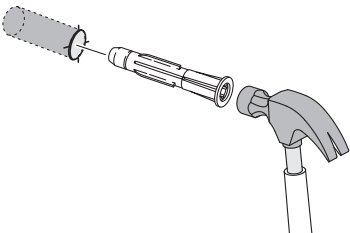
**3** 

**C**

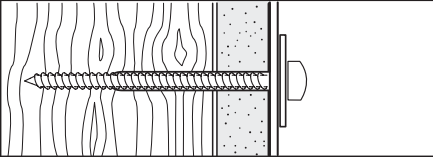

**Ø 3 mm (1/8")** 

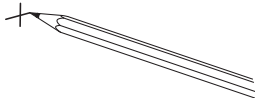
**1** 

**2**  ≈ 30 mm (≈ 1 1/4")

**3** 

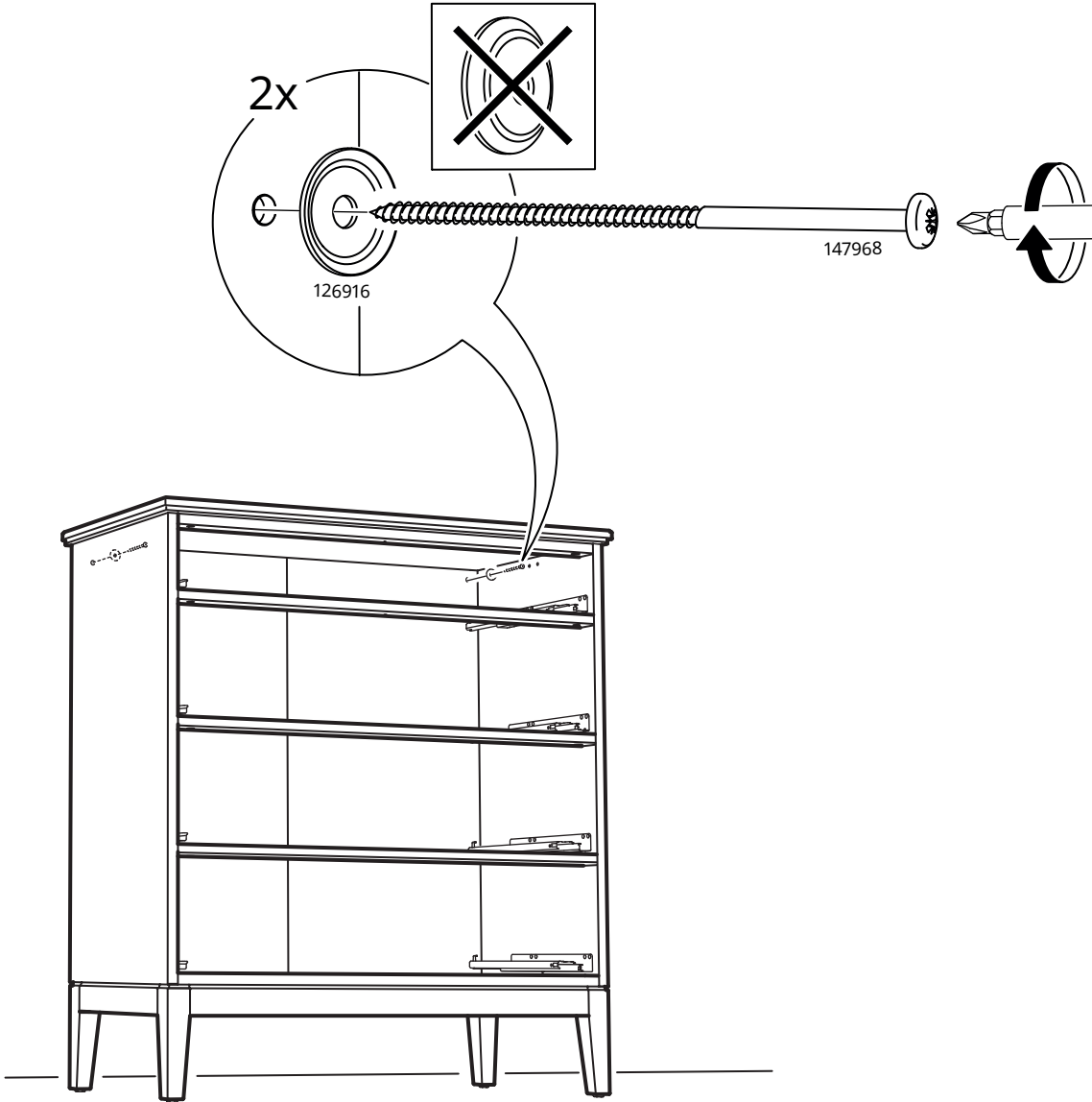

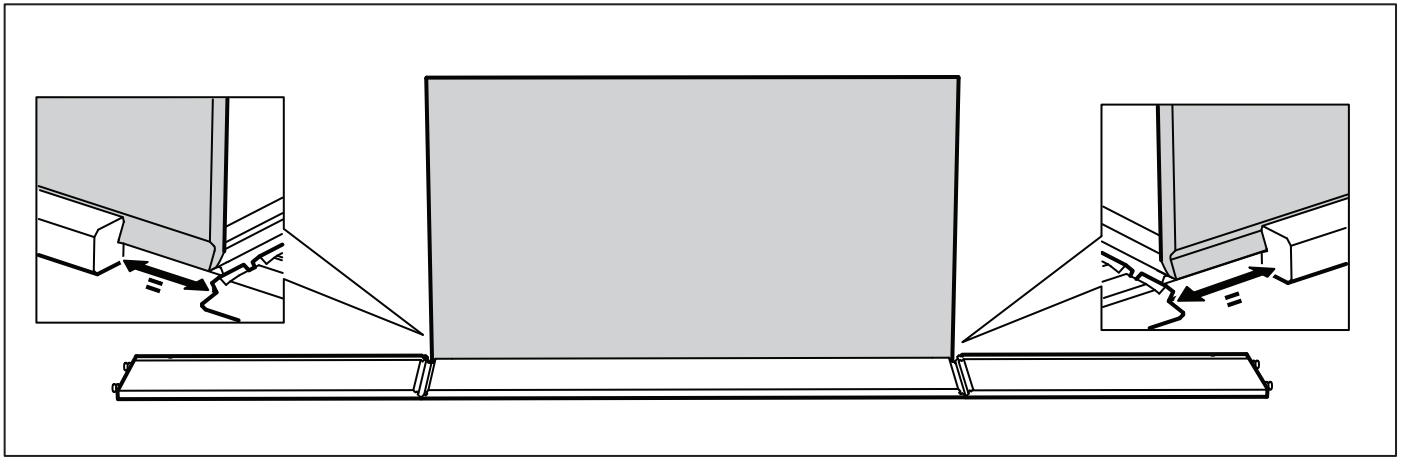

**28**

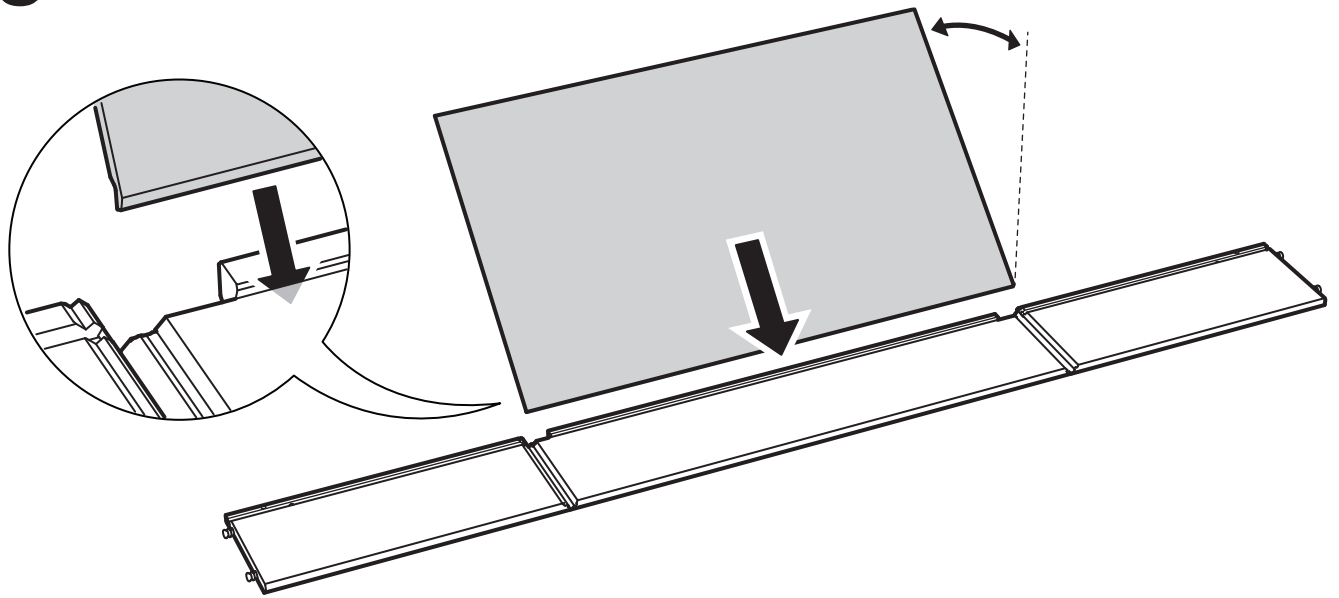

**29**

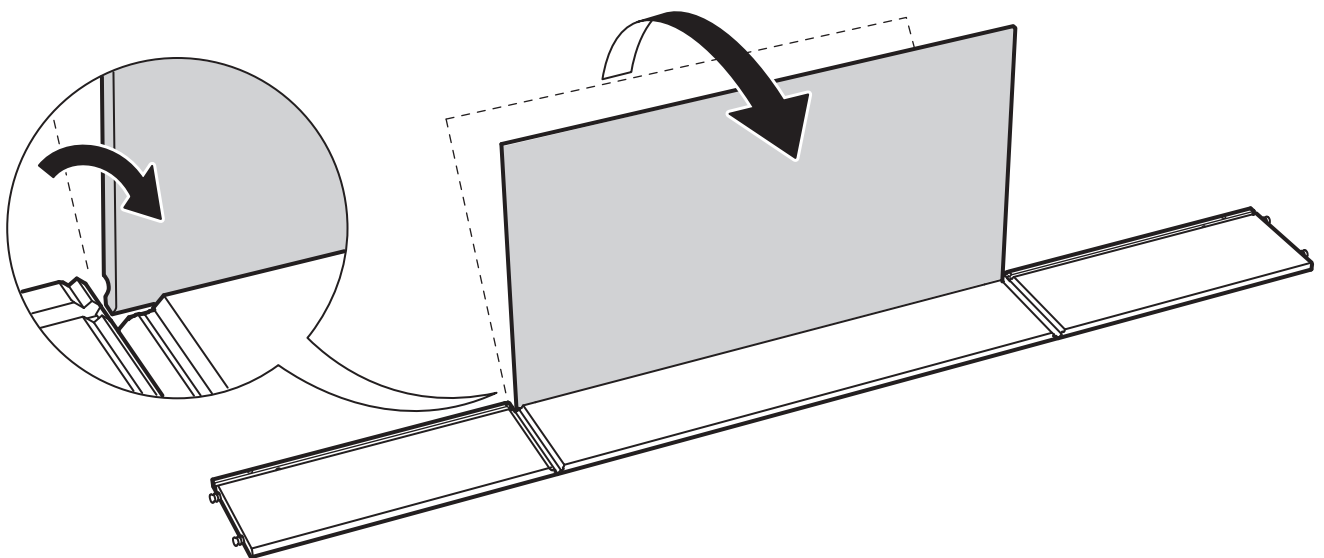

**30**

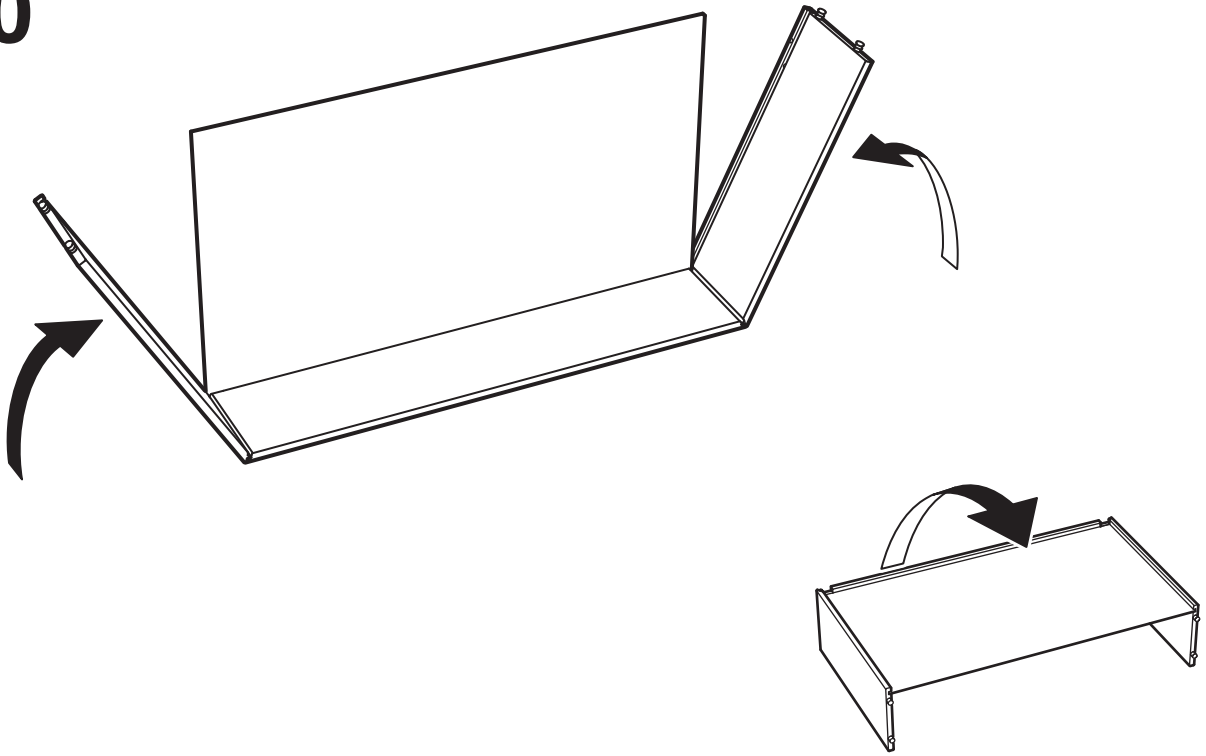

**31**

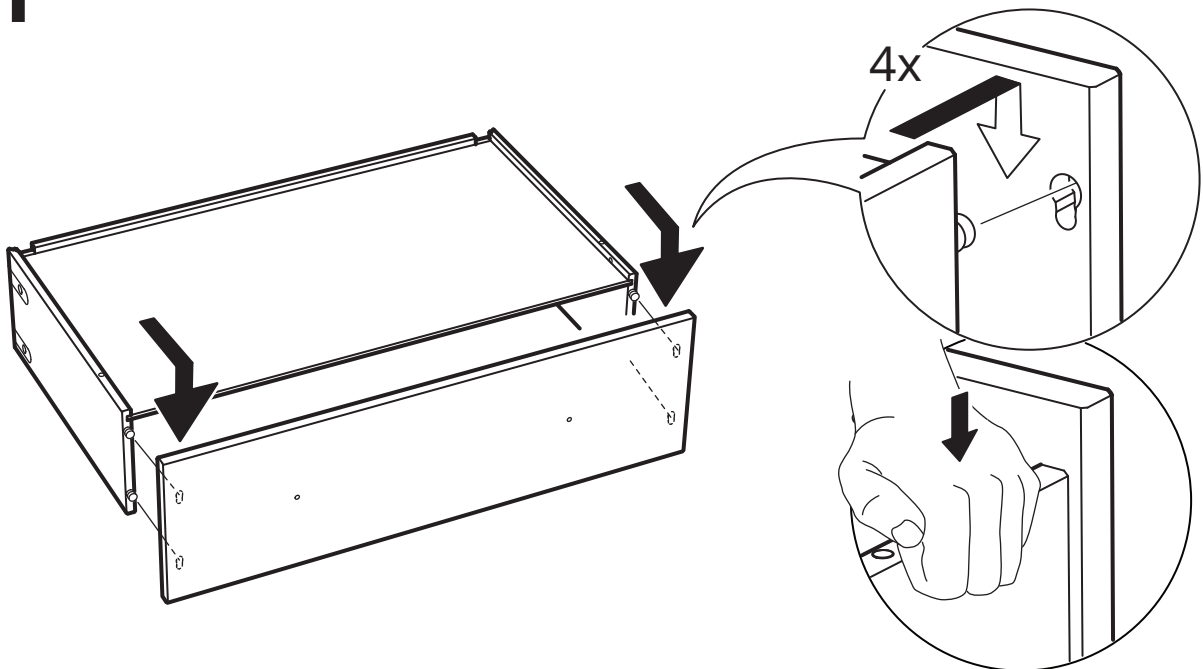

32

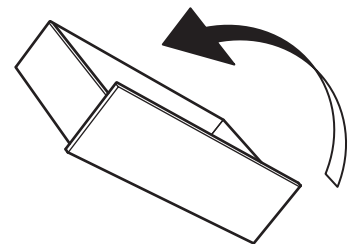
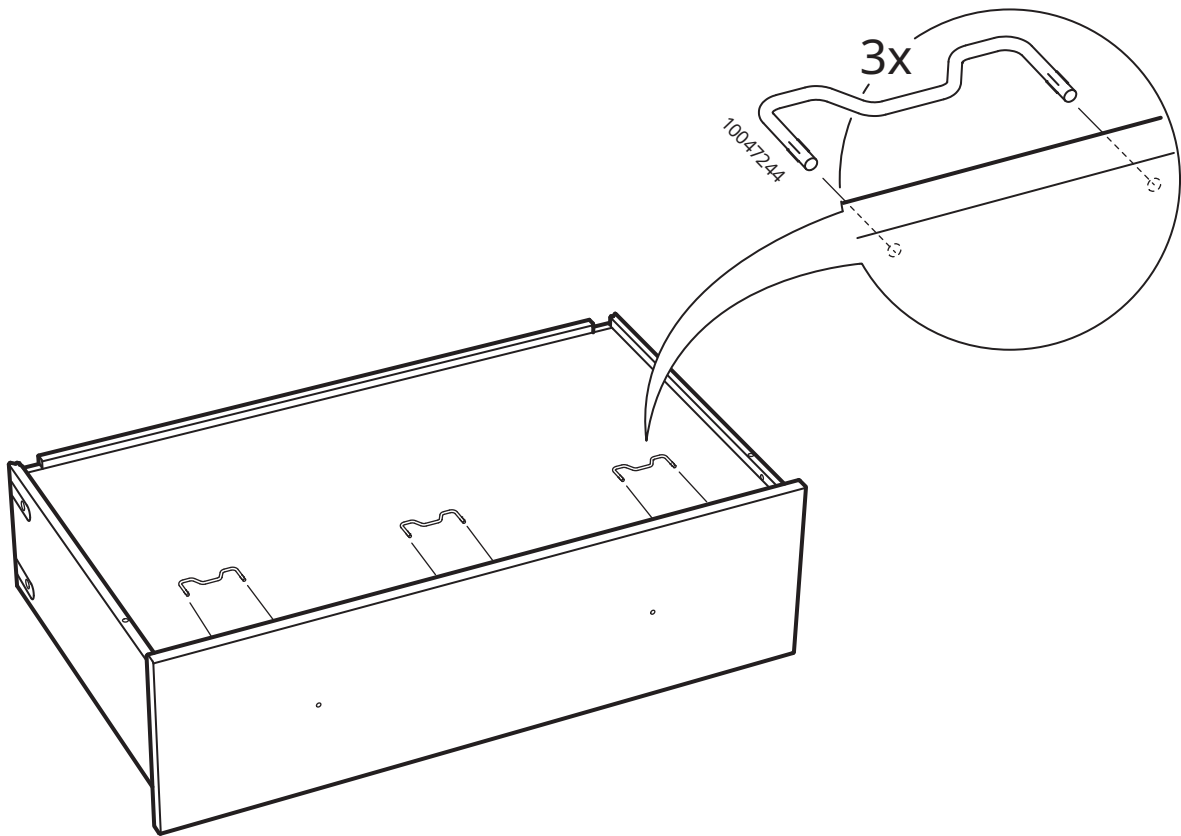
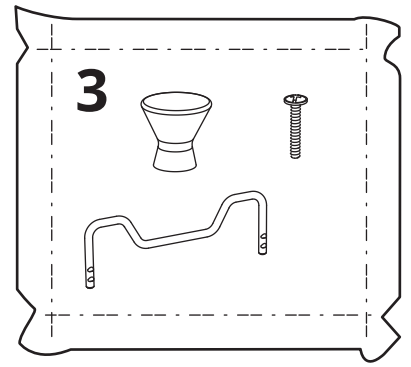

# 33

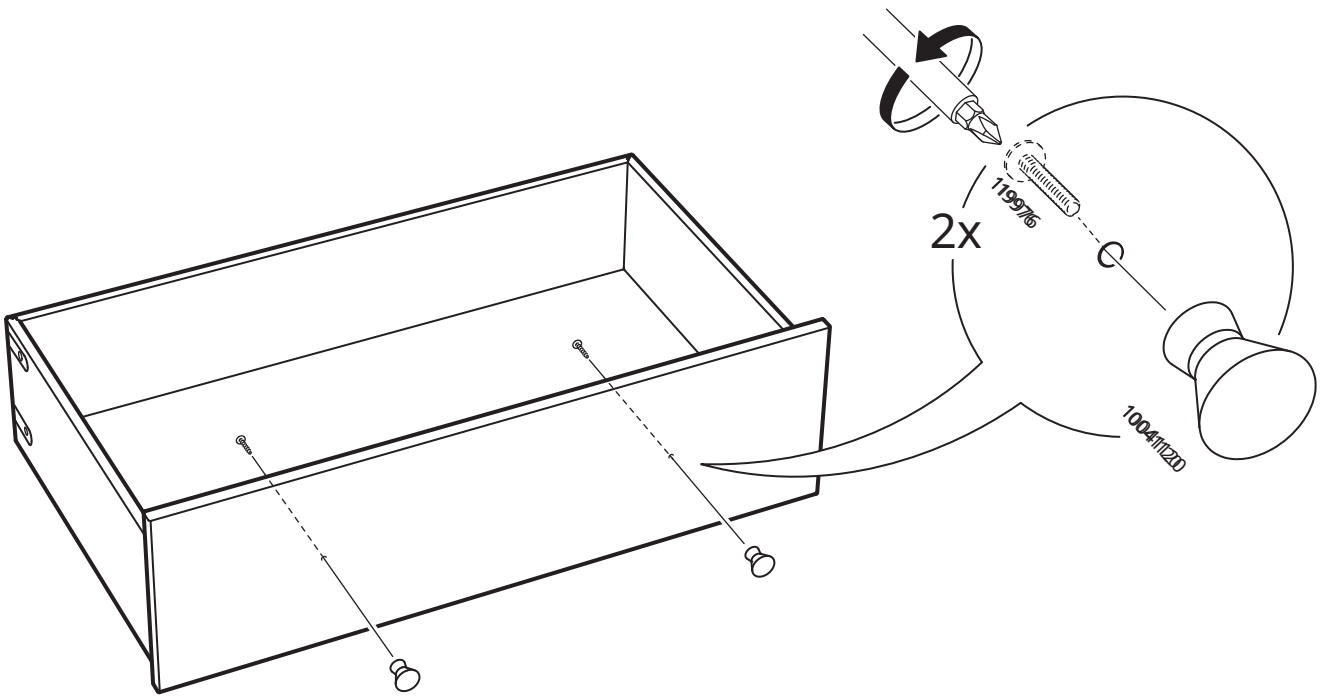

# 34

