

SLADDA

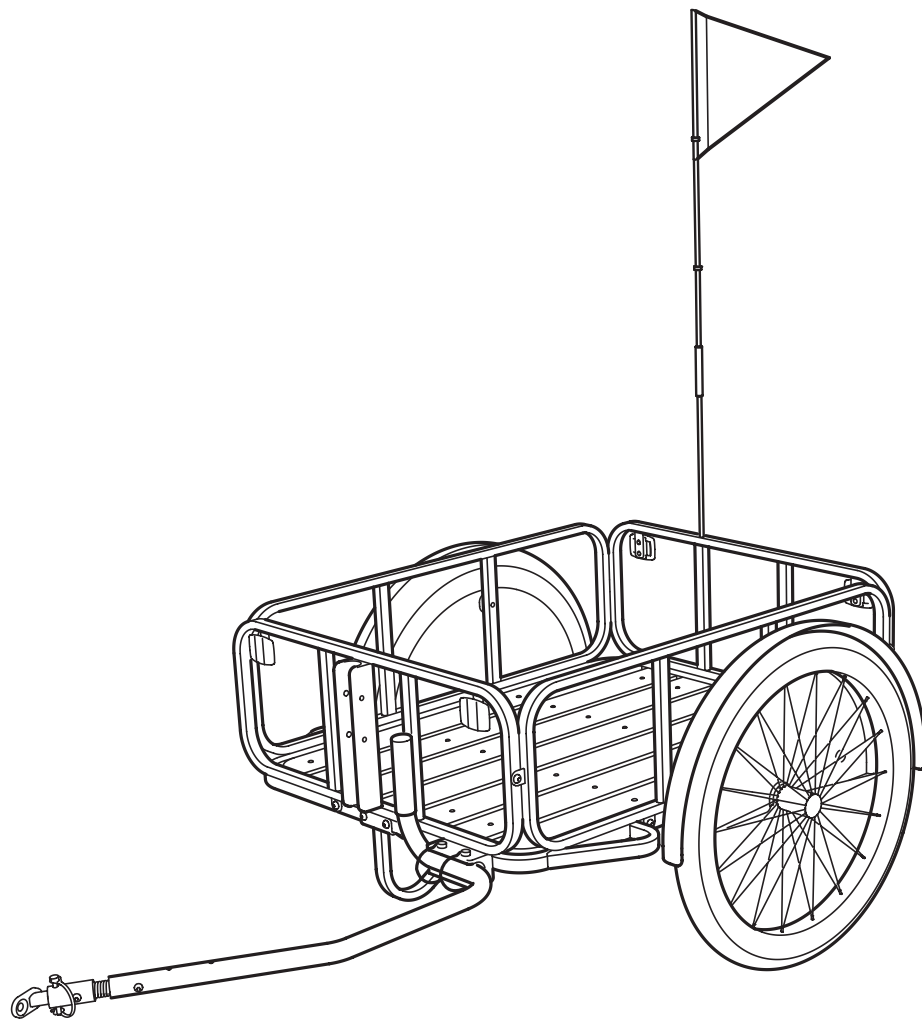

Design and Quality
IKEA of Sweden

ENGLISH	4
DANSK	15
SUOMI	26
SVENSKA	37

ENGLISH

CONTENTS

1. WARNING	4
2. SAFETY	4
3. CARE AND MAINTENANCE	4
4. TRAILER PARTS & COMPONENTS	5
5. ASSEMBLE YOUR TRAILER	6
6. TEST YOUR TRAILER	12

1. WARNING



- **Warning!** Your braking distance will increase when biking with a trailer.
- Fits SLADDA bicycle 26" and 28".
- **NOTE!** If you want to use this trailer with a different bicycle, make sure to check the bicycle manual for suitable fittings and trailers. Please note! Never connect the trailer to a mountain bike, racing bike, e-bike or any other bicycle that has motor assistance.
- SLADDA trailer is not suitable for transporting children or animals. Follow the manual to assemble and use the trailer in a correct and safe way.

2. SAFETY

For your own safety, always follow the traffic rules in your country.

3. CARE AND MAINTENANCE

Make sure to check the trailer components, such as assembly screws, fittings, frame, reflective and tyres regularly.

IKEA of Sweden AB
34381 Älmhult
Sweden

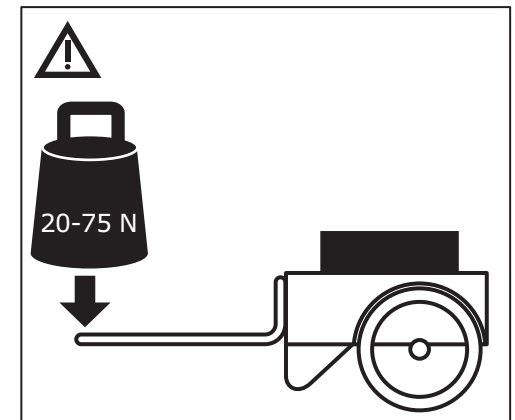
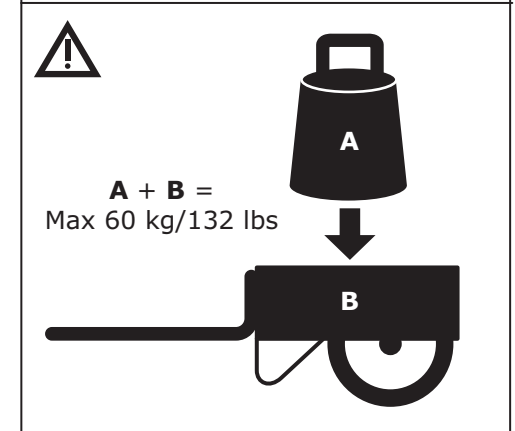
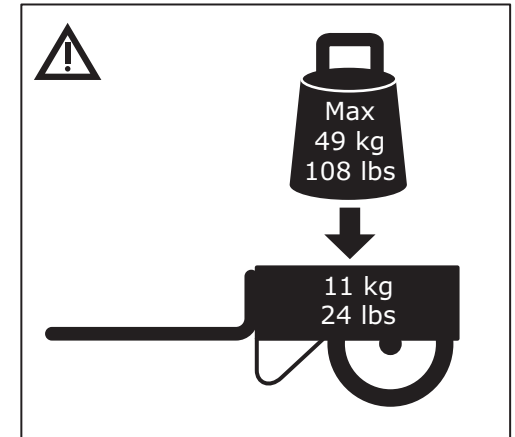

4. TRAILER PARTS & COMPONENTS

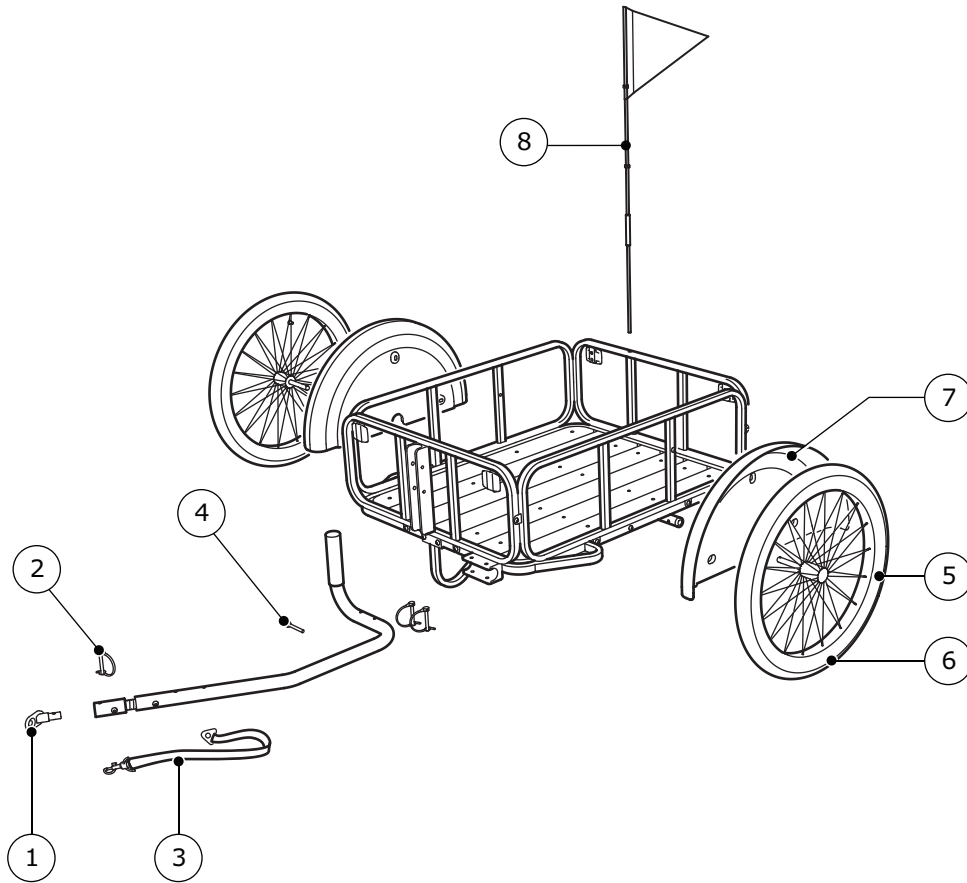

- 1 Connector (152921)
- 2 D-shape locker (152922)
- 3 Safety strap (152923)
- 4 M5 Screw (152924)
- 5 Tire, inner tube (152925)
- 6 Tire (152926)
- 7 Fender (152927)
- 8 Flag (192282)

5. ASSEMBLE YOUR TRAILER

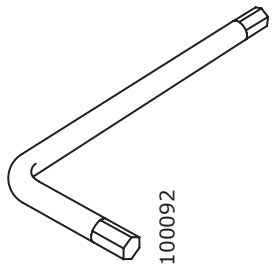
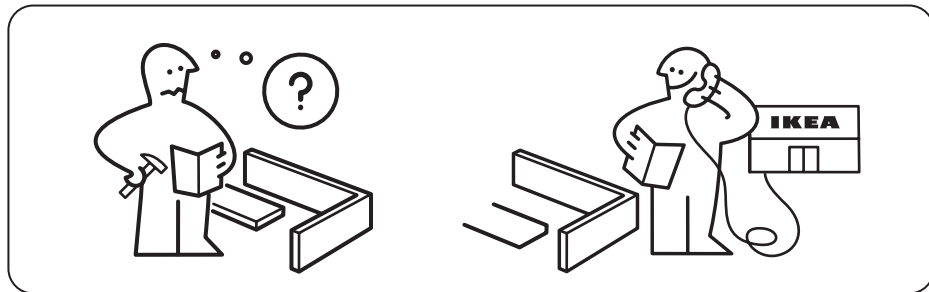
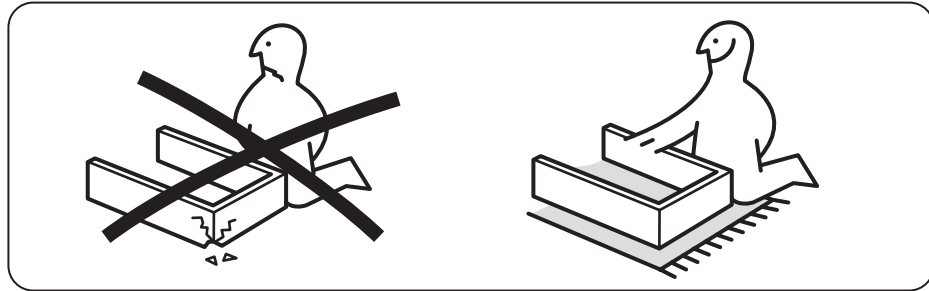
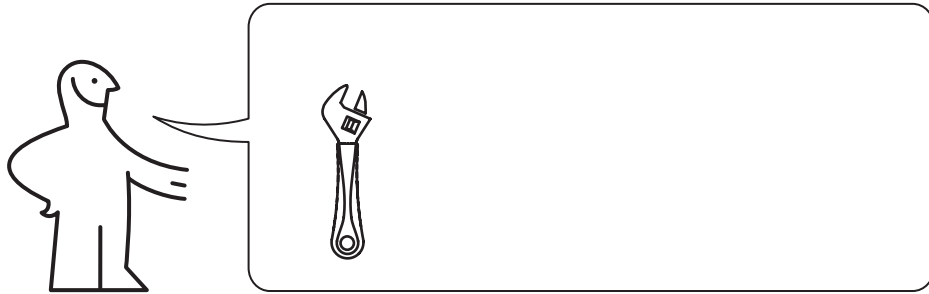

1x



22x



6x

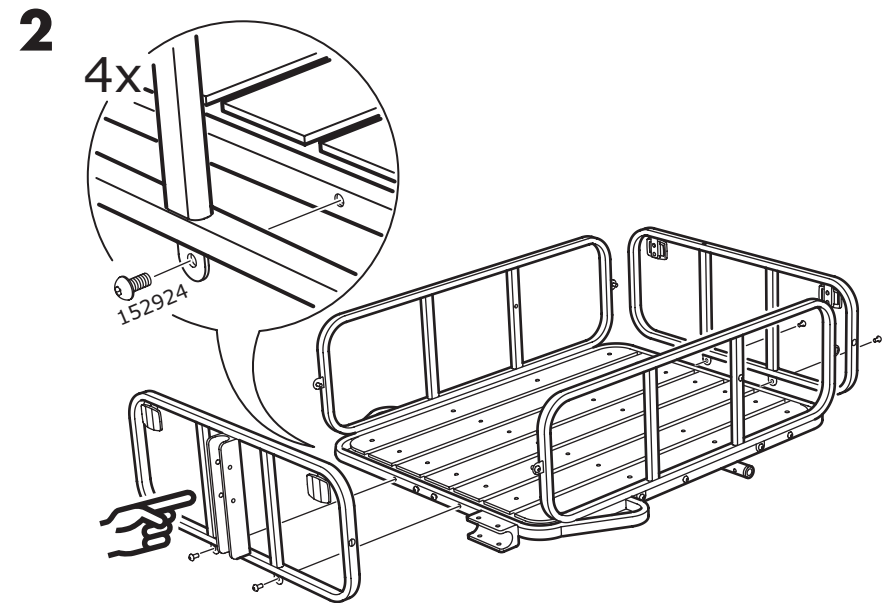
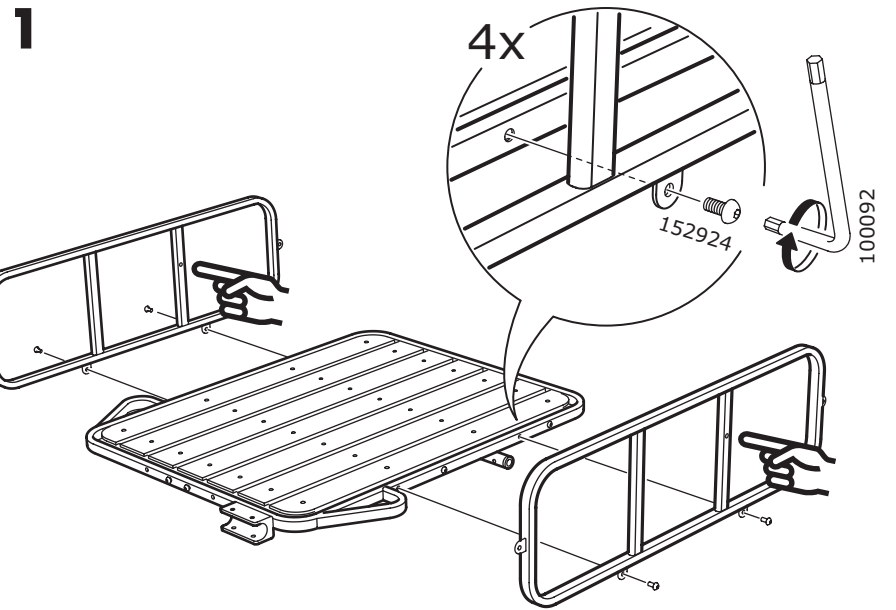

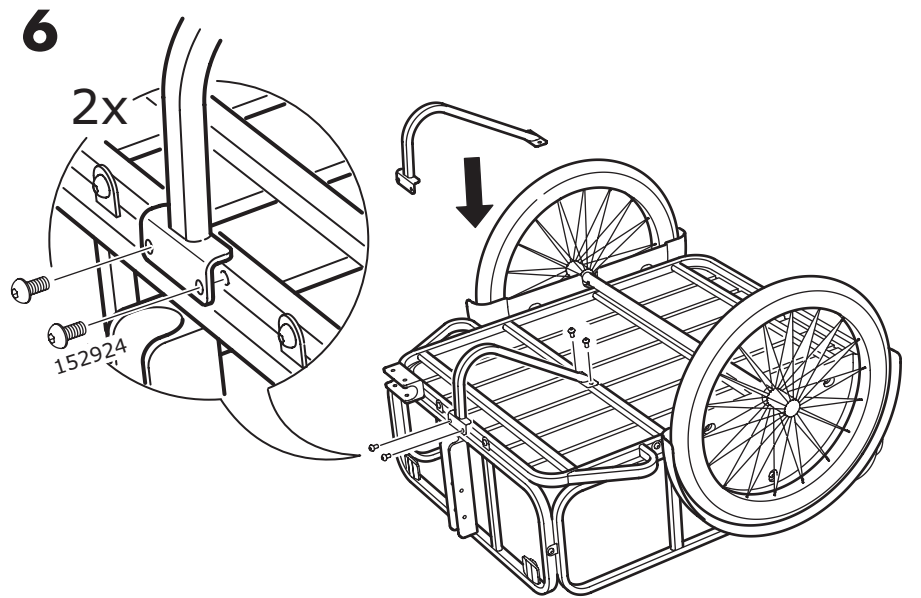
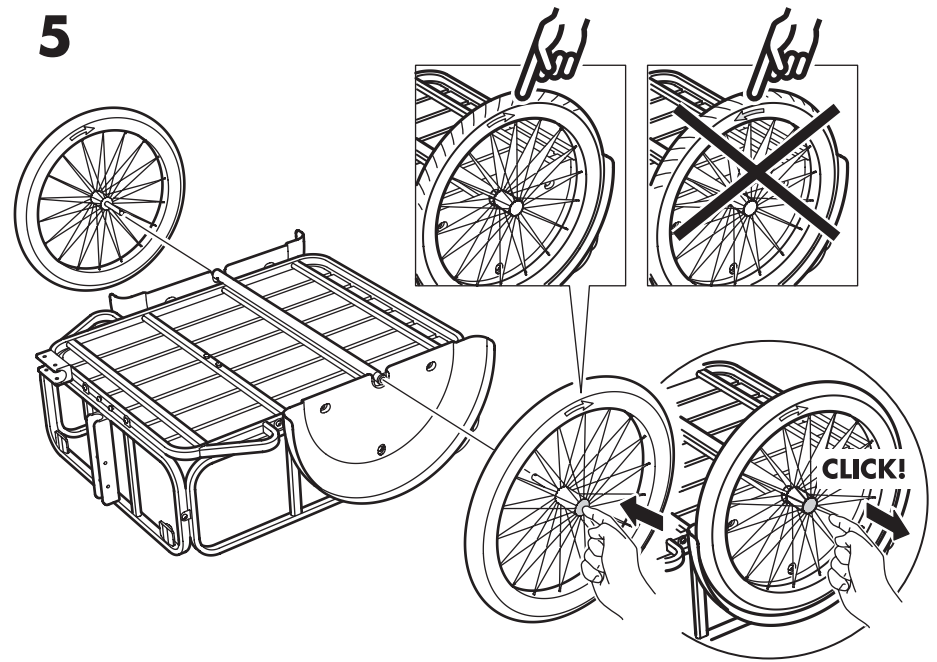
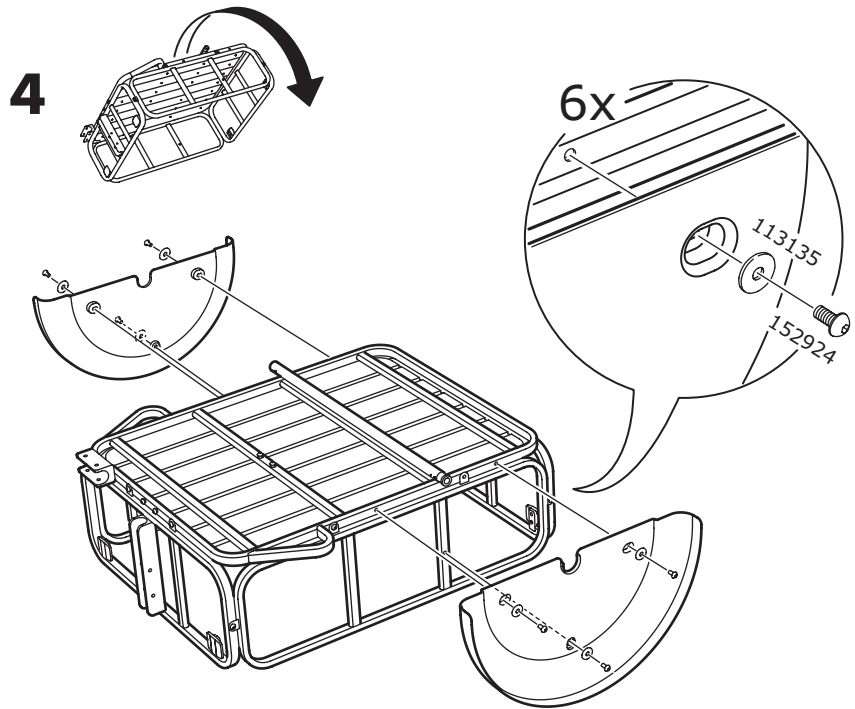
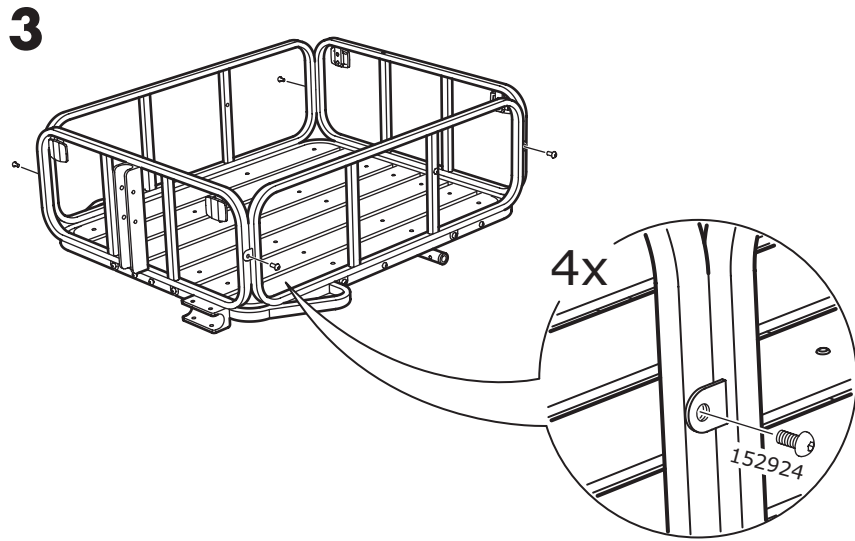

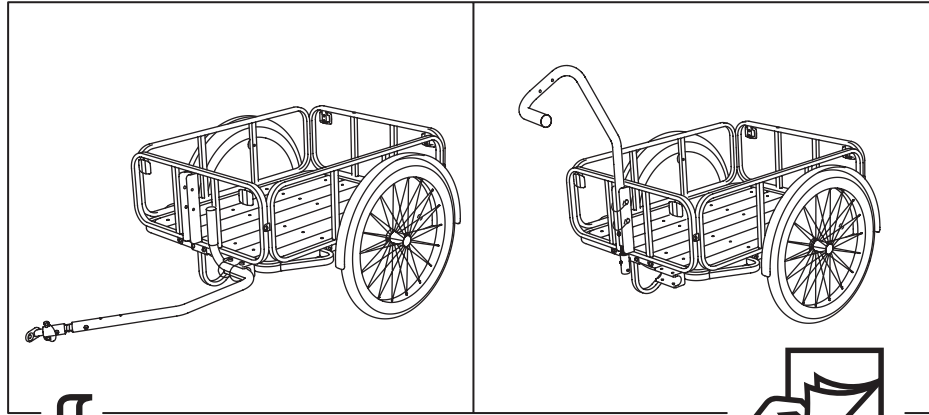

7

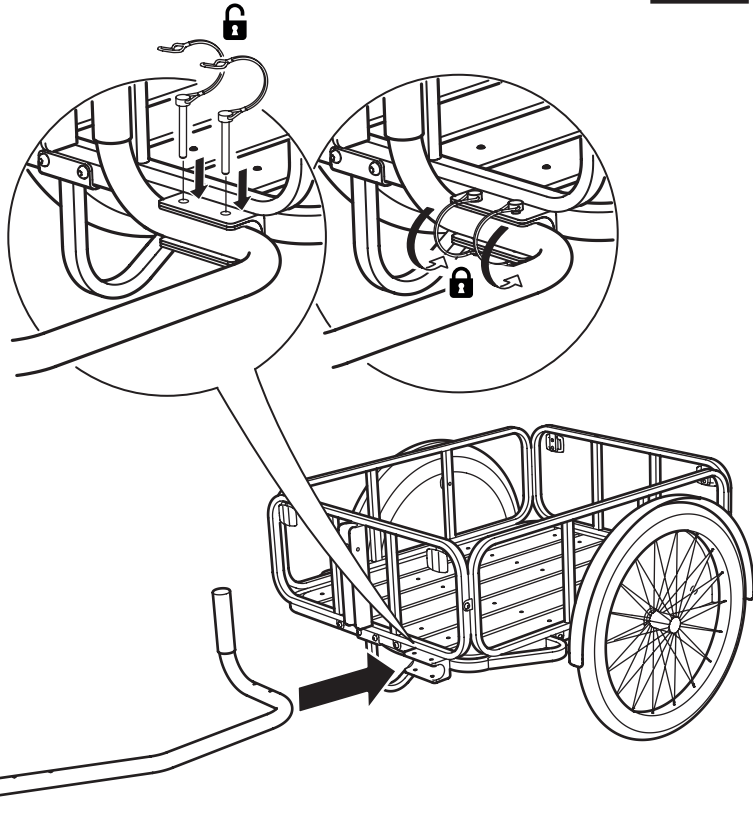

8

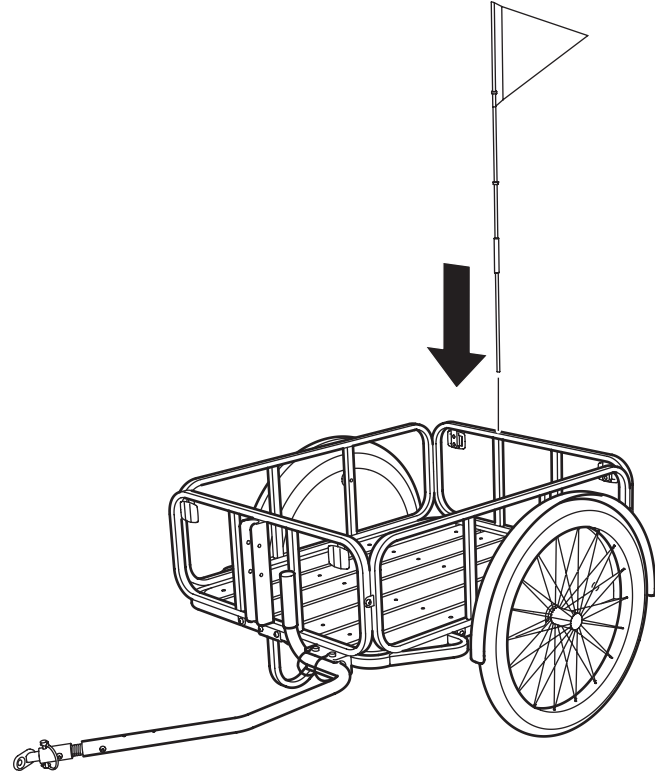

9

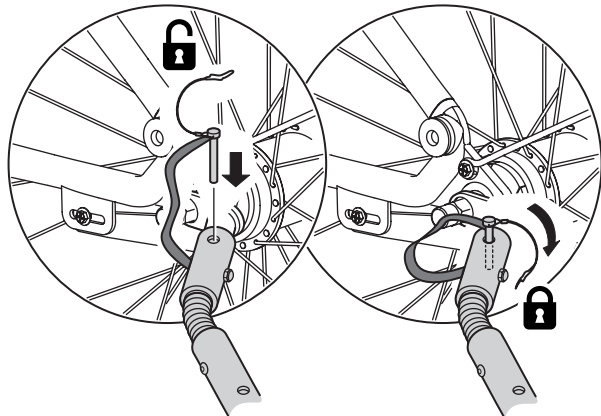
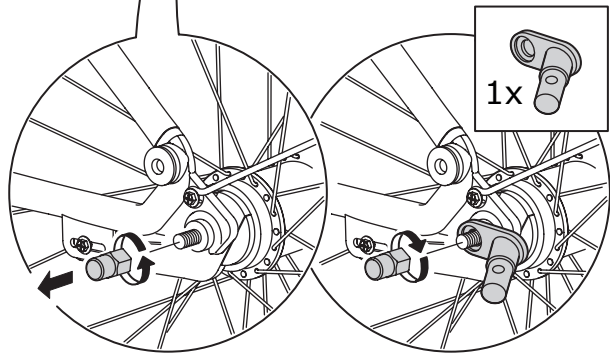
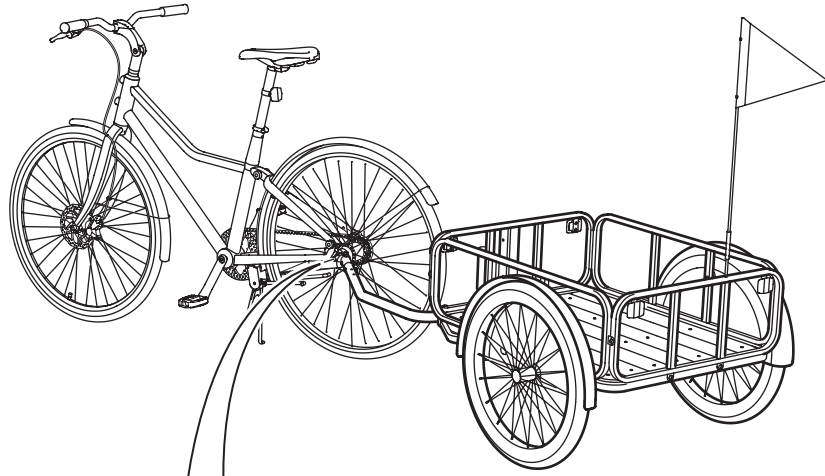

10

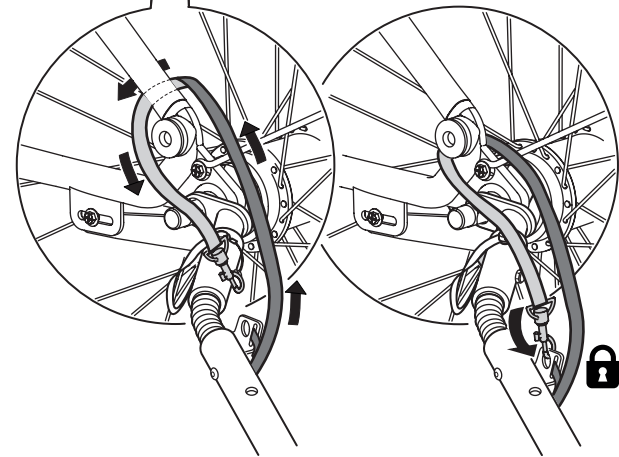
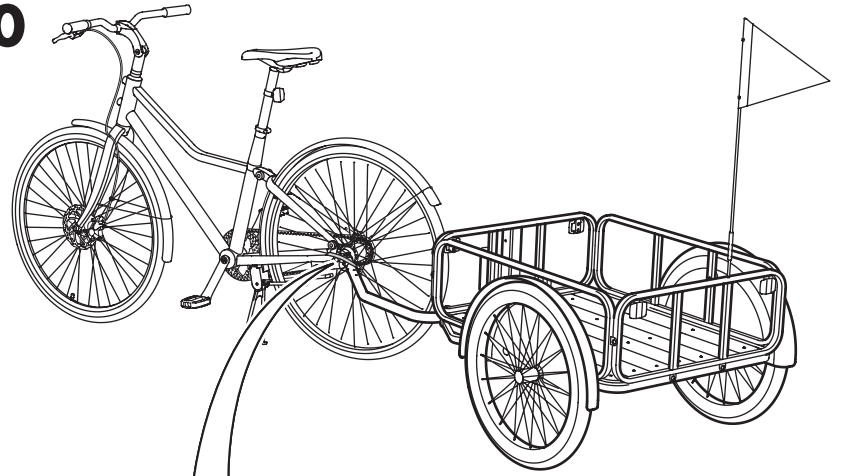

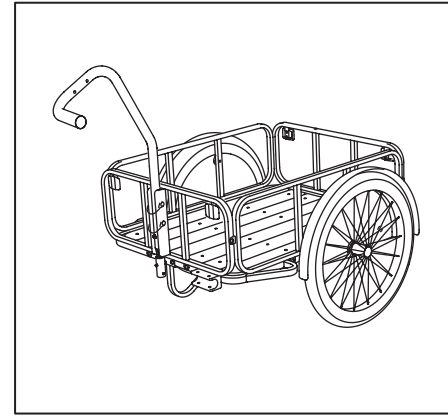
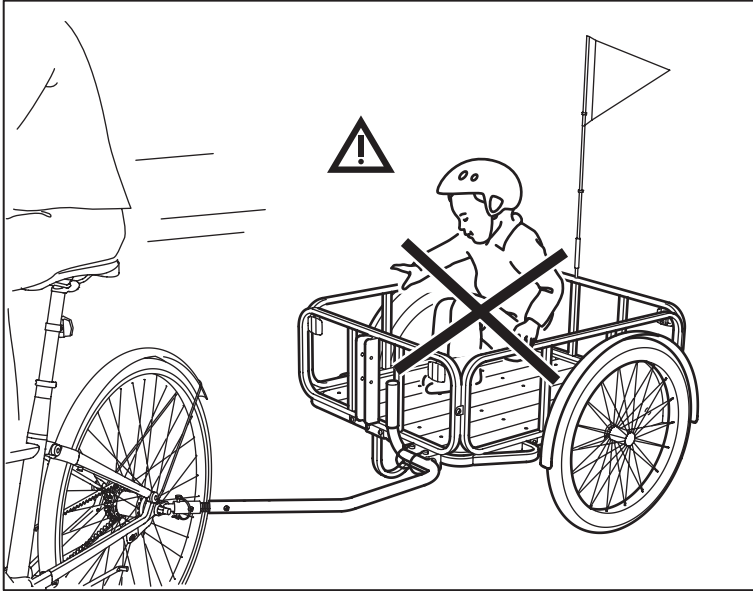

7

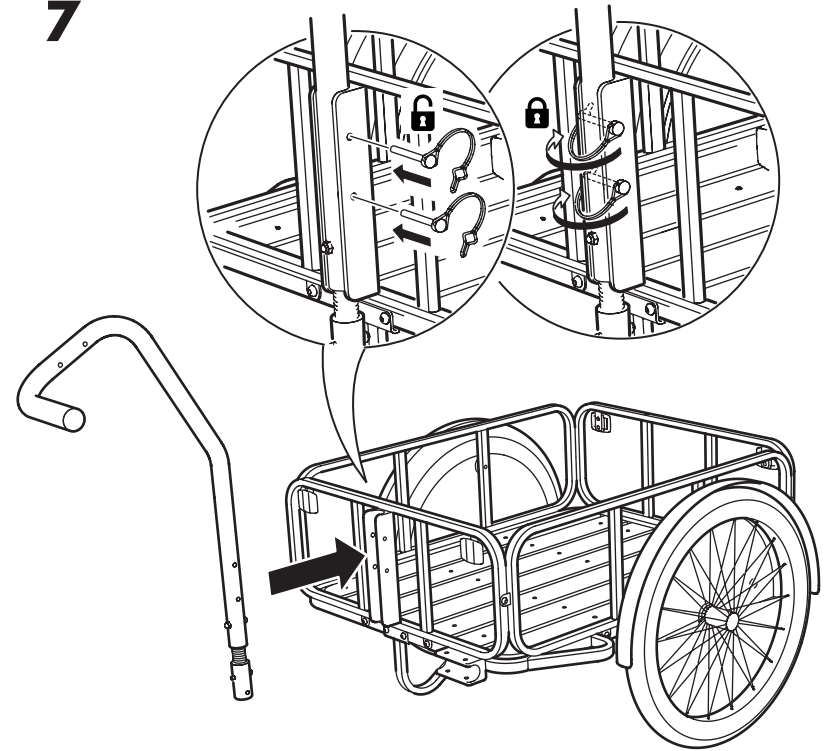

8

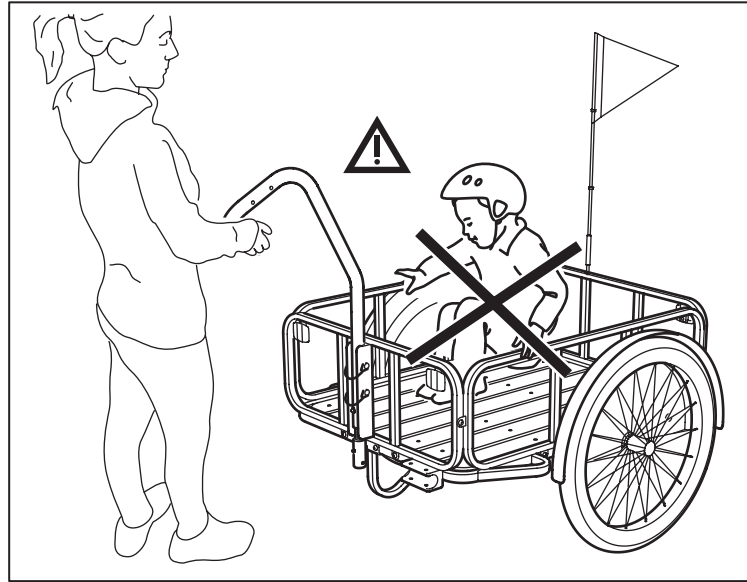
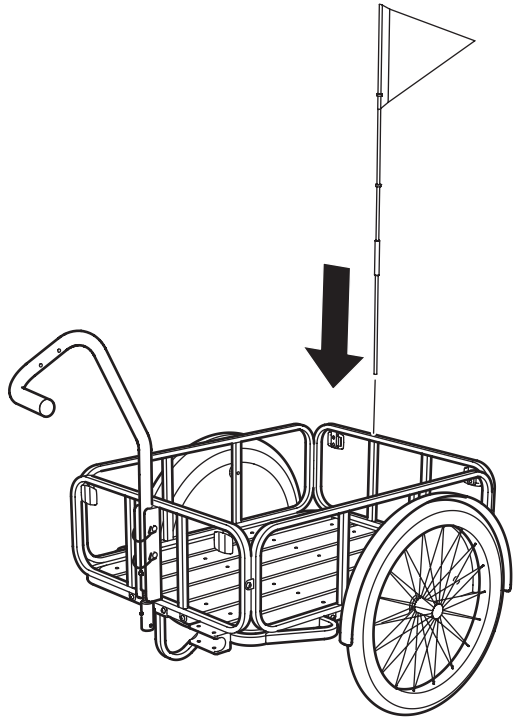

6. TEST YOUR TRAILER

Before using your trailer you should perform a safety check on level ground and away from heavy traffic. It is important that you ensure all parts are fastened and working properly.

TEST THE TYRES

Make sure that the tyres are inflated to the recommended pressure limit using a tyre pump with a gauge. The pressure should not exceed the recommended limit as stated on the tyre. It is better to use a hand or foot pump rather than a service station pump as over inflation can cause the tyre to blow out.

CHECK REFLECTORS

Check that reflectors are positioned correctly.



WARNING: *As with all mechanical components, the trailer is subjected to wear and high stress. Different materials and components may react to wear or stress fatigue in different ways. If the design life of a component has been exceeded, it may suddenly fail possibly causing injuries to the rider. Any form of cracks, scratches or change of colouring in highly stressed areas indicate that the life of the component has been reached and it should be replaced.*

DANSK

INDHOLD

1. ADVARSEL	13
2. SIKKERHED	13
3. PLEJE OG VEDLIGEHOLDELSE	13
4. DELE OG KOMPONENTER	14
5. MONTER DIN ANHÆNGER	15
6. TEST DIN ANHÆNGER, FØR DU BRUGER DEN	21

1. ADVARSEL



- **ADVARSEL!** Bremselængden øges, når du cykler med en anhænger.
- Passer til SLADDA cykel 26" og 28".
- **BEMÆRK!** Hvis du vil bruge denne anhænger på en anden cykel, skal du sørge for at kontrollere i brugsanvisningen til cyklen, hvilke beslag og anhængere den kan bruges sammen med. Bemærk! Du må aldrig montere anhænger på en mountain bike, racercykel, elcykel andre andre former for cykler med motor.
- SLADDA anhænger er ikke beregnet til transport af børn eller dyr. Følg brugsanvisningen, så du monterer og bruger anhænger korrekt og sikkert.

2. SIKKERHED

Af hensyn til din egen sikkerhed skal du altid følge færdselsreglerne i dit land.

3. PLEJE OG VEDLIGEHOLDELSE

Sørg for at kontrollere anhængerens komponenter jævnlige, f.eks. monteringskruer, beslag, stel, refleksstriber og dæk.

IKEA of Sweden AB
34381 Älmhult
Sweden

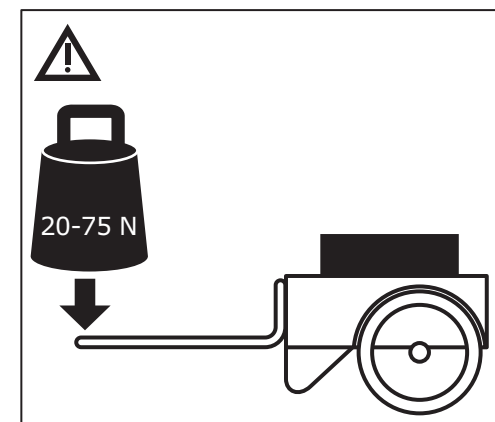
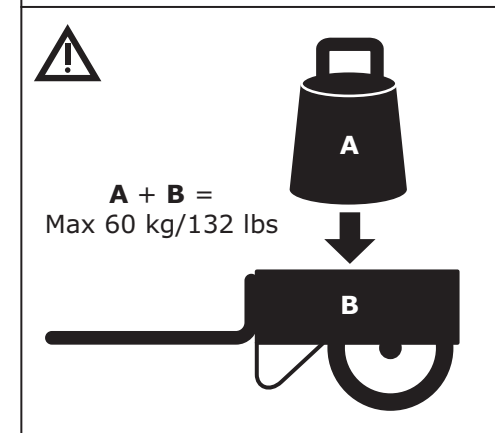
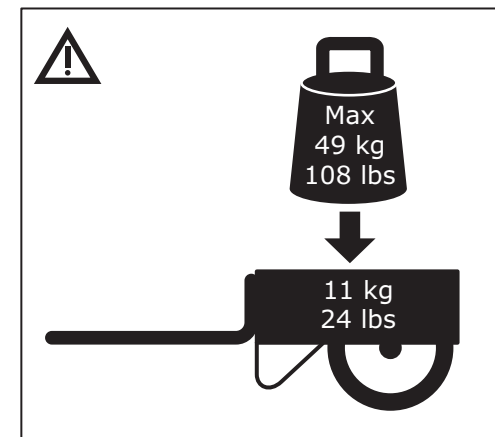

4. DELE OG KOMPONENTER

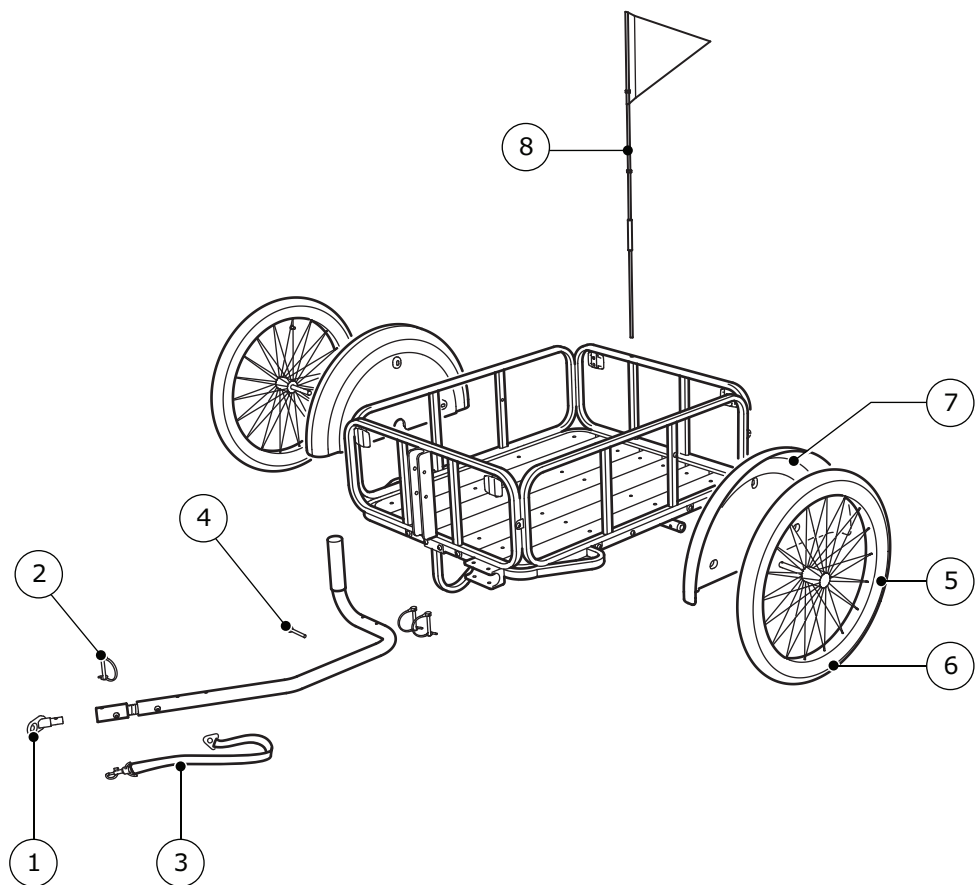

- 1 Forbindelsesled (152921)
- 2 D-formet sjækel (152922)
- 3 Sikkerhedsstrop (152923)
- 4 M5-skrue (152924)
- 5 Dæk, slange (152925)
- 6 Dæk (152926)
- 7 Skærm (152927)
- 8 Flag (192282)

5. MONTER DIN ANHÆNGER

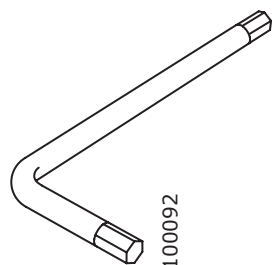
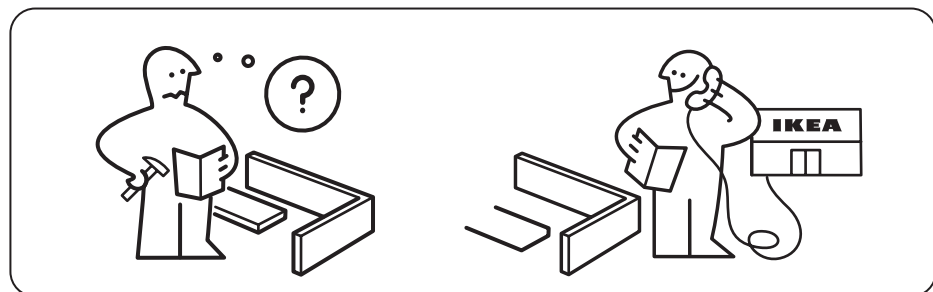
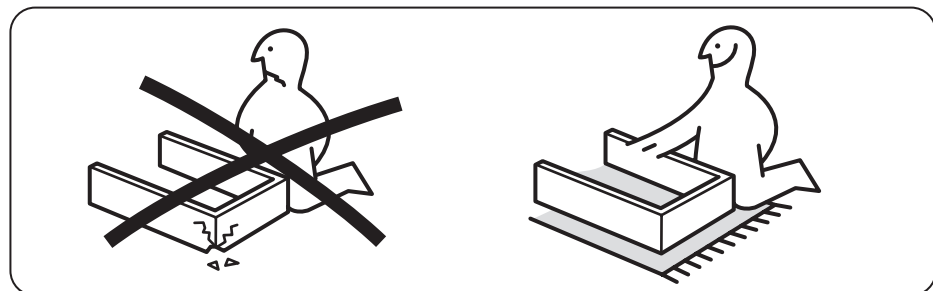
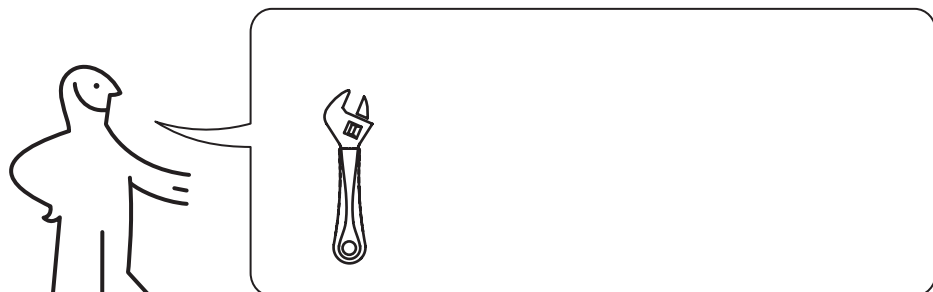

1x

100092



22x

152924



6x

113135

1

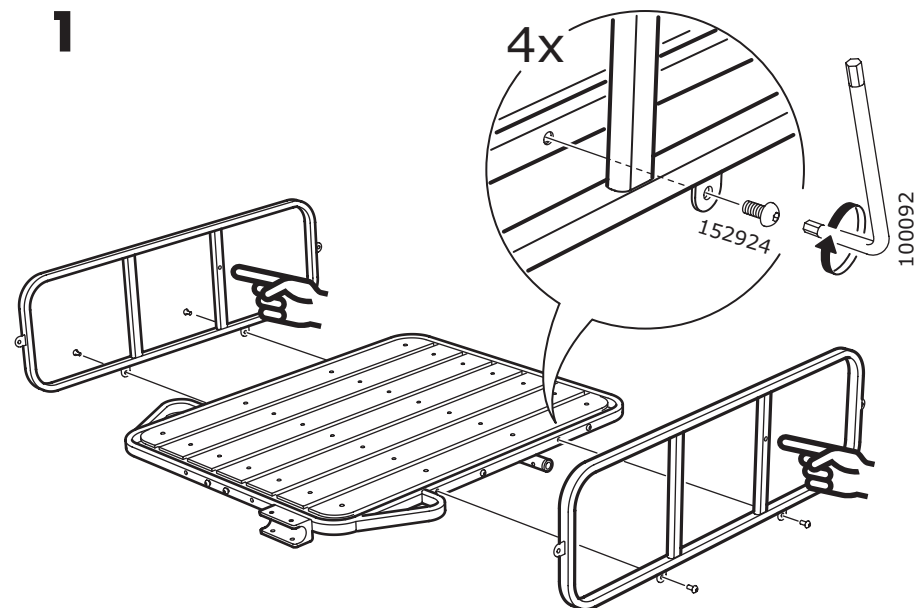

2

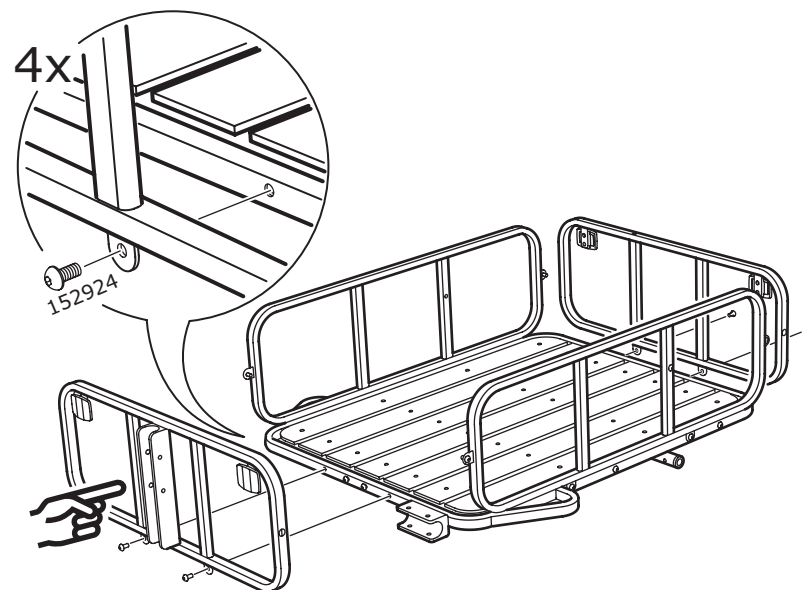

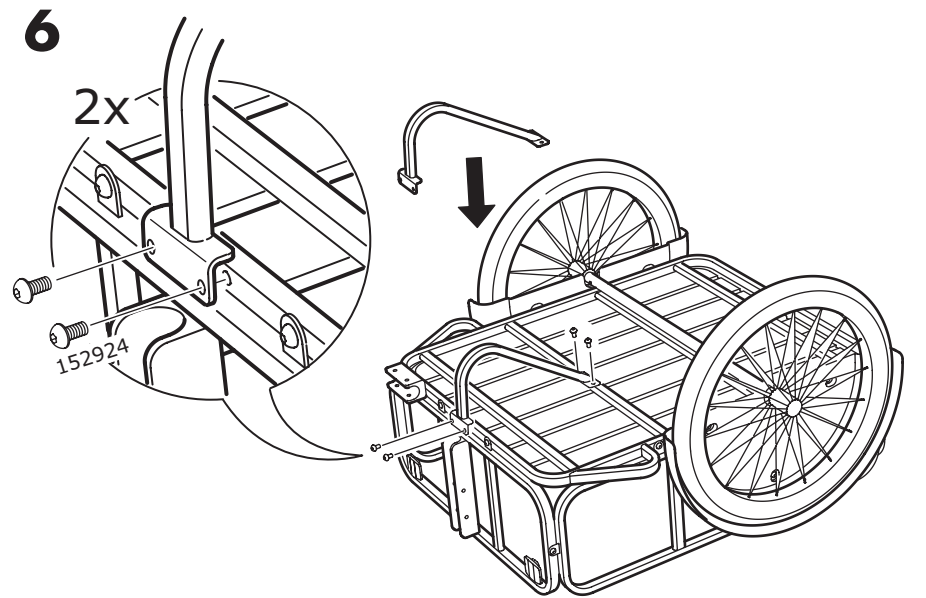
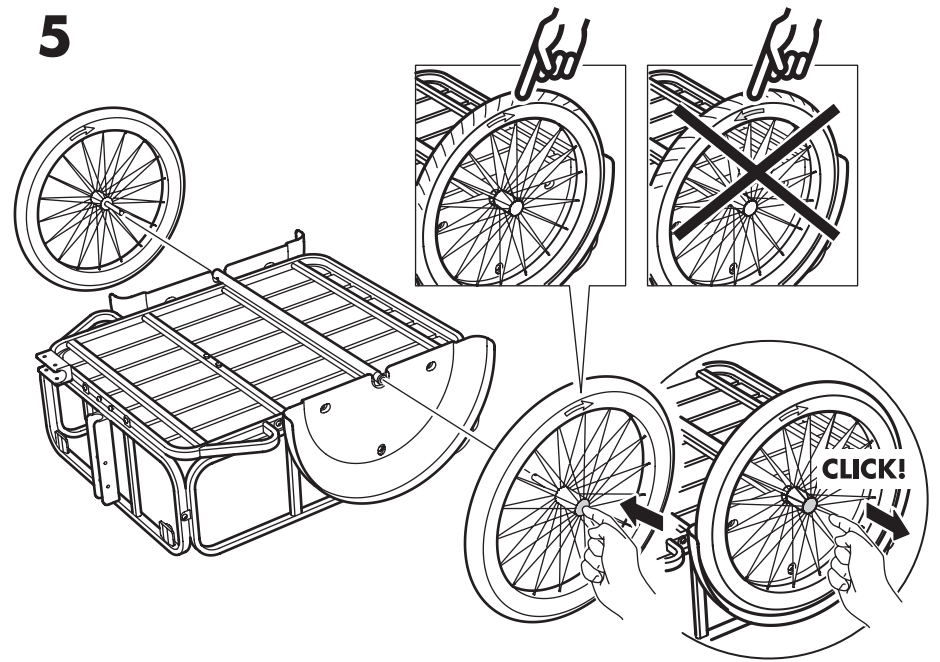
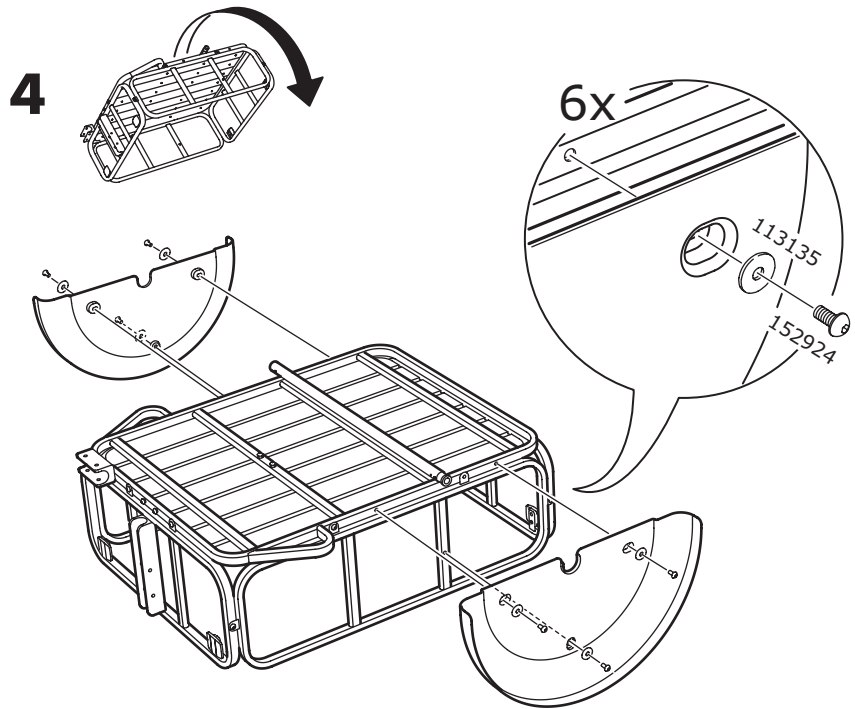
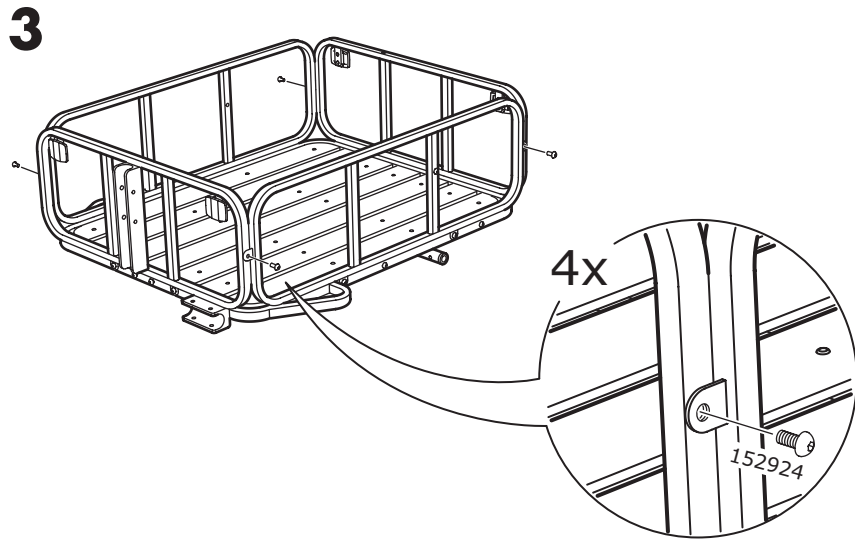

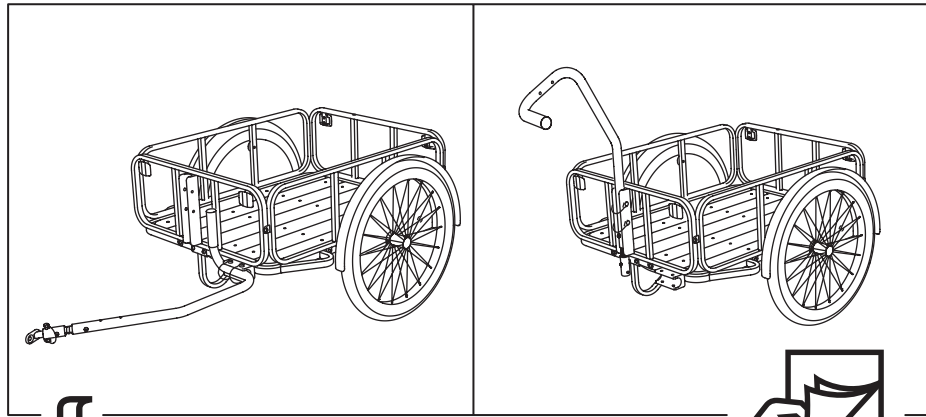

7

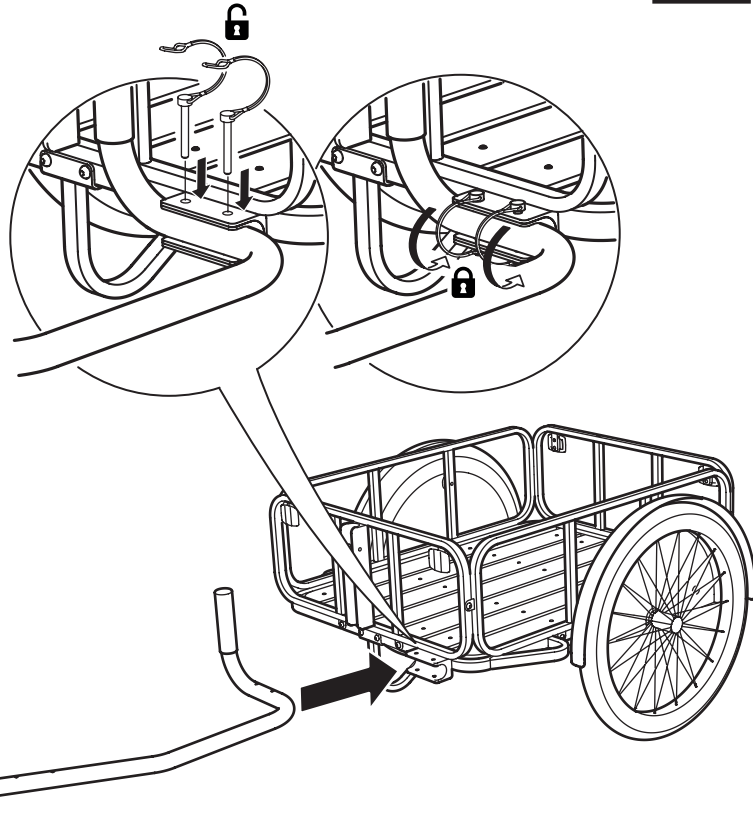

8

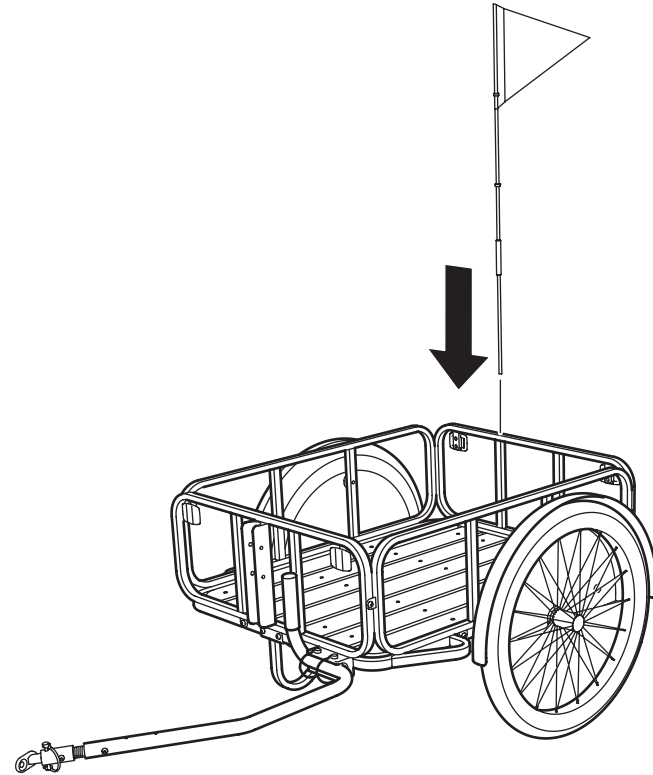

9

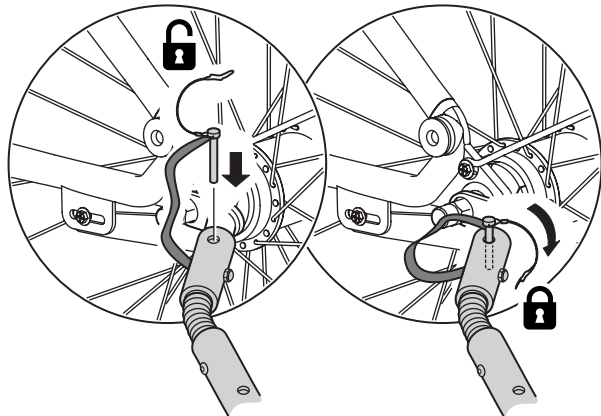
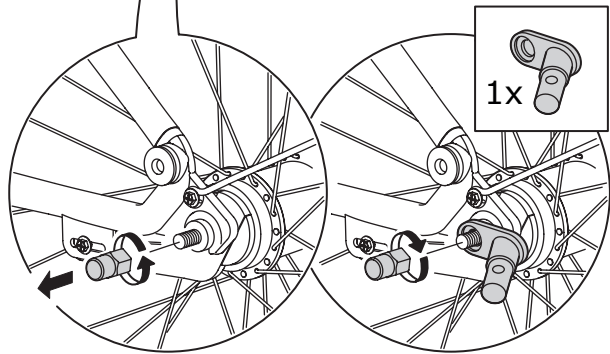
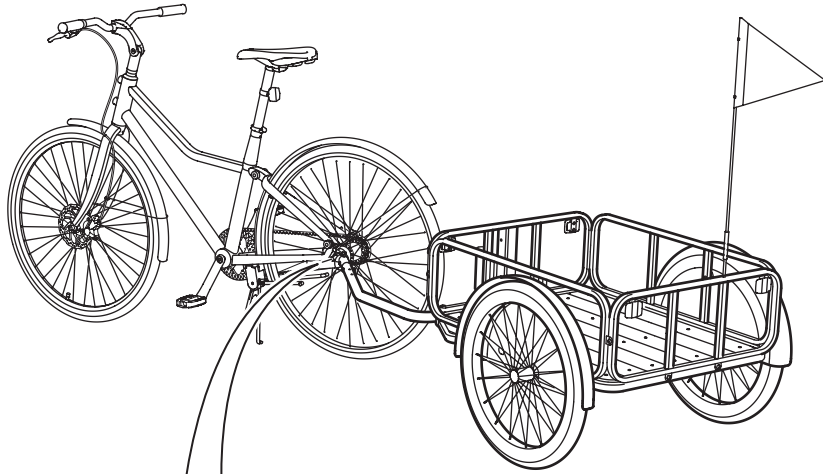

10

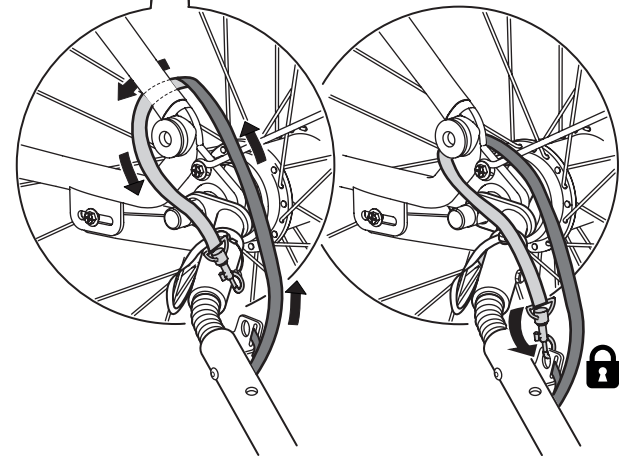
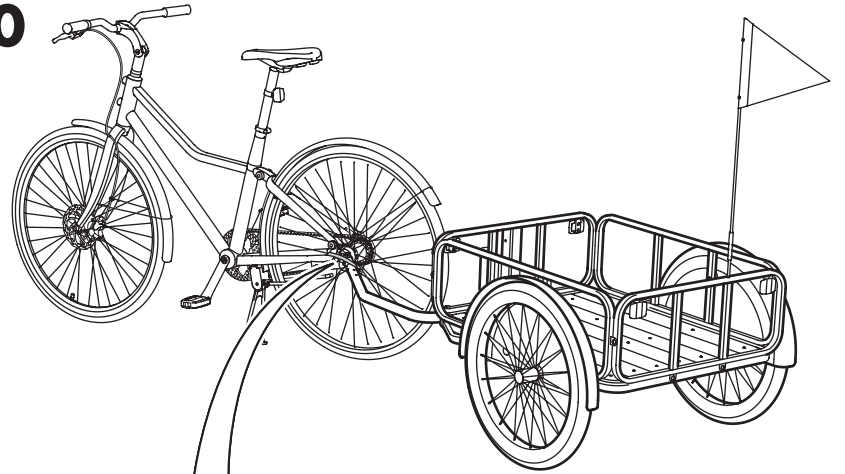

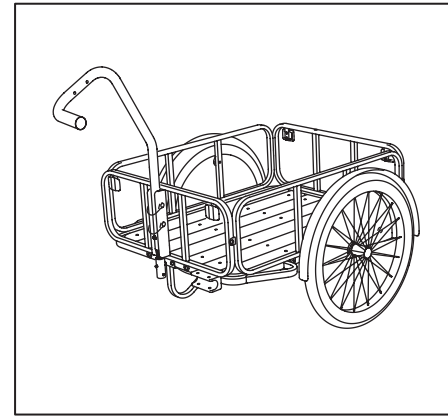
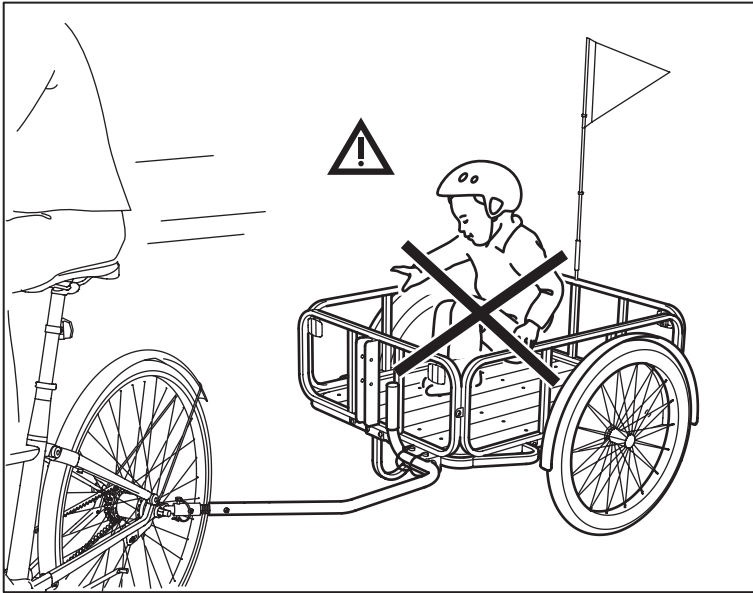

7

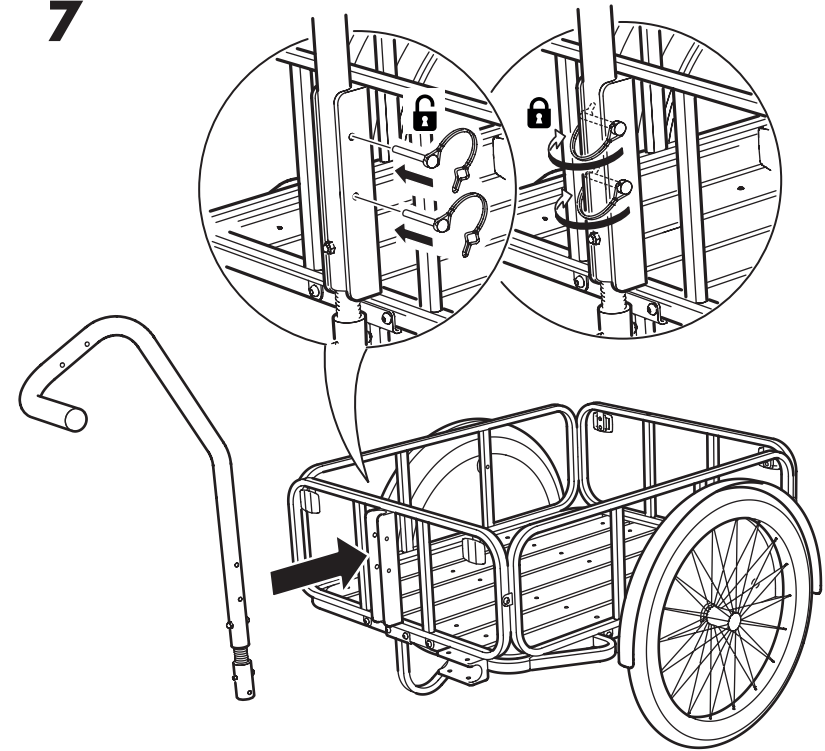

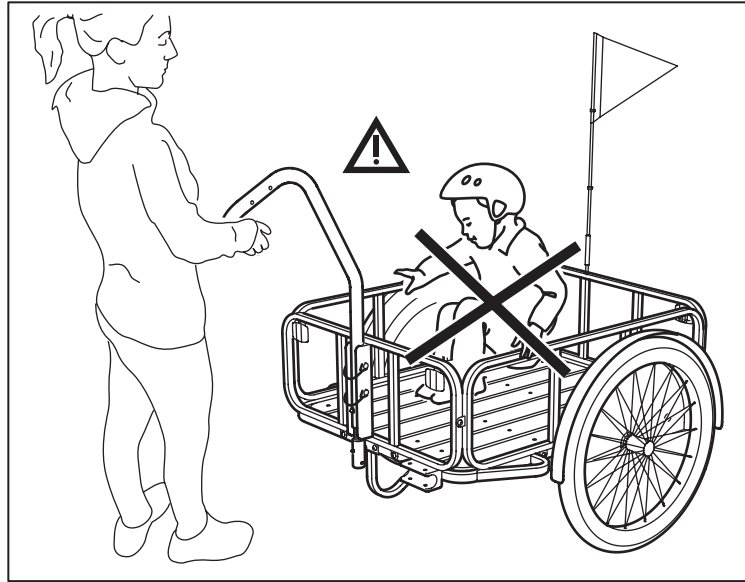
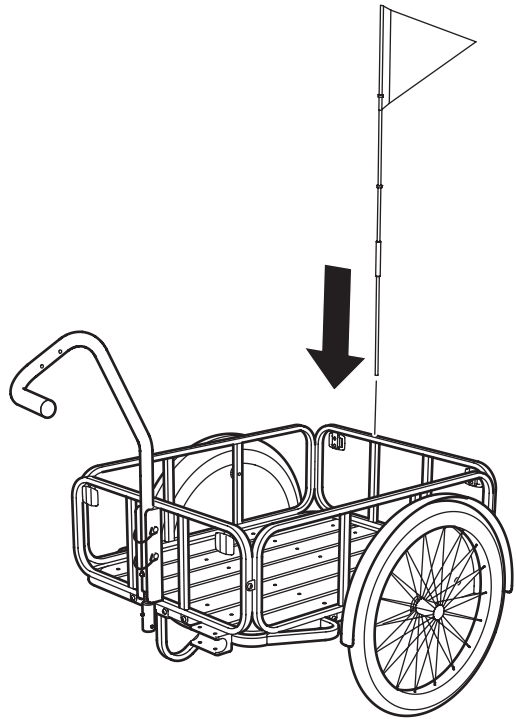

6. TEST DIN ANHÆNGER, FØR DU BRUGER DEN

Før du bruger anhængerene, bør du gennemføre et sikkerhedstjek på et jævnt underlag og væk fra tung trafik. Det er vigtigt, at du sikrer, at alle dele er spændt og fungerer korrekt.

TEST DÆKKENE

Sørg for, at dækkene er pumpet op til det anbefalede dæktryk ved at bruge en pumpe med måler. Trykket bør ikke overstige det anbefalede tryk, der er angivet på dækket. Det er bedre at bruge en hånd- eller fodpumpe, ikke en pumpe på en servicestation, da slangen kan springe, hvis dækket pumpes for hårdt.

KONTROLLÉR REFLEKSERNE

Kontrollér, at reflekserne er placeret korrekt.



ADVARSEL! Ligesom alle andre mekaniske komponenter udsættes anhængerene for slid og høj belastning. Forskellige materialer og komponenter kan reagere på forskellige måder på slid eller belastning. Hvis en komponents holdbarhed er overskredet, kan den pludselig svigte og muligvis forårsage personskade på cyklisten. Alle former for revner, ridser eller farveændringer i områder, der er udsat for stor belastning, kan være et tegn på, at komponentens holdbarhed er udløbet, og den bør udskiftes.

SISÄLLYSLUETTELO

1. VAROITUS	22
2. TURVALLISUUSOHJEITA	22
3. HUOLTO JA KUNNOSSAPITO	22
4. PYÖRÄN OSAT	23
5. PYÖRÄN KOKOAMINEN	24
6. PYÖRÄN TESTAAMINEN ENNEN KÄYTTÖÄ	30

1. VAROITUS



- **Varoitus!** Pyörän jarrutusmatka on tavallista pidempi peräkärryn kanssa ajettaessa.
- Sopii käytettäväksi SLADDA 26" tai SLADDA 28" -polkupyörän kanssa.
- **HUOM!** Jos haluat käyttää peräkärystä jonkin muun polkupyörämallin kanssa, varmista kyseisen polkupyörän ohjekirjasta, mitkä kiinnikkeet ja peräkärret siihen sopivat. Huom! Älä koskaan kiinnitä peräkärystä maastopyörään, kilpapyörään tai sähköpyörään tai muuhun moottoriavusteiseen pyörään.
- SLADDA-peräkärri ei sovi lasten tai eläinten kuljettamiseen. Noudata kokoamisohjetta ja kokoa peräkärri oikein ja turvallisesti.

2. TURVALLISUUS

Oman turvallisuutesi vuoksi noudata aina tieliikennelakia.

3. PUHDISTUS JA HOITO

Tarkista peräkärryn osat, kuten kiinnitysruuvit, kiinnikkeet, runko, heijastimet ja renkaat, säännöllisesti.

IKEA of Sweden AB
34381 Älmhult
Sweden

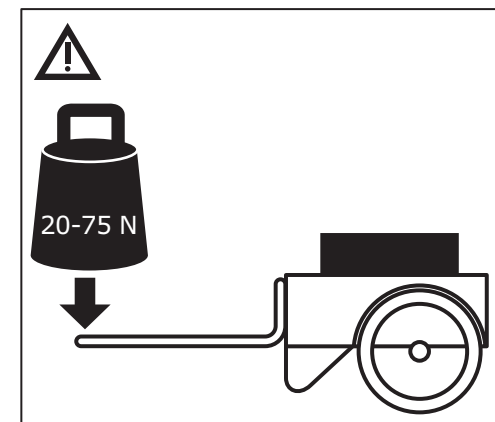
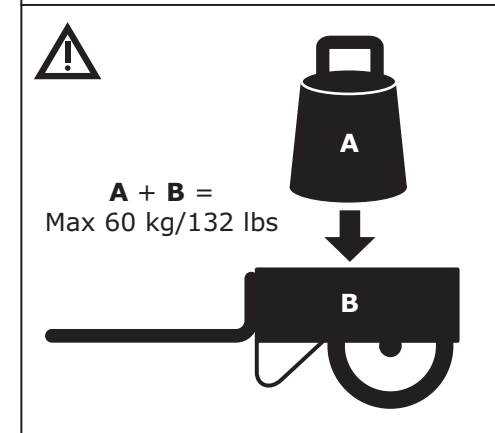
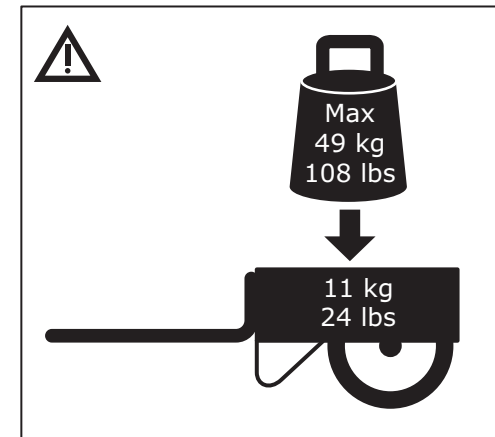

4. PYÖRÄN OSAT

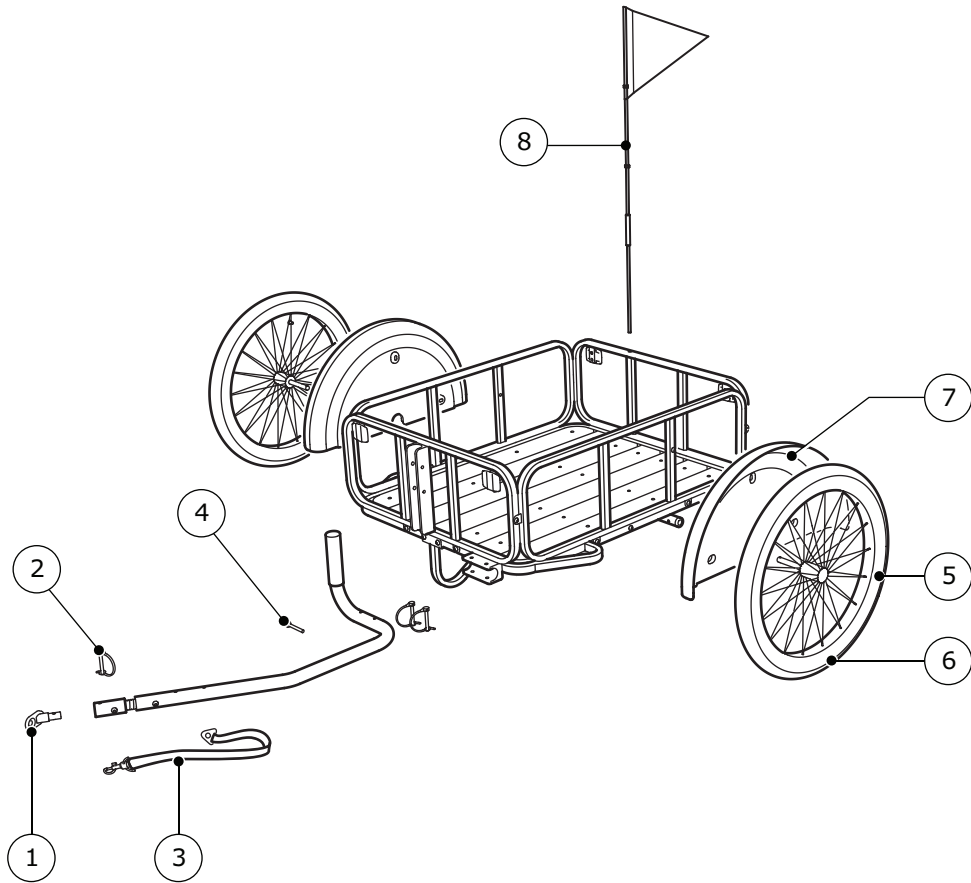

- 1 Kiinnityskappale (152921)
- 2 D-rengaslukko (152922)
- 3 Turvahihna (152923)
- 4 M5-ruuvi (152924)
- 5 Renkaan sisäkumi (152925)
- 6 Rengas (152926)
- 7 Lokasuoja (152927)
- 8 Lippu (192282)

5. PYÖRÄN KOKOAMINEN

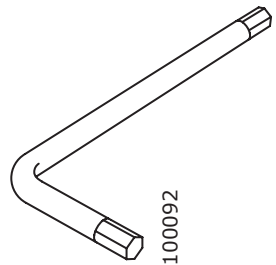
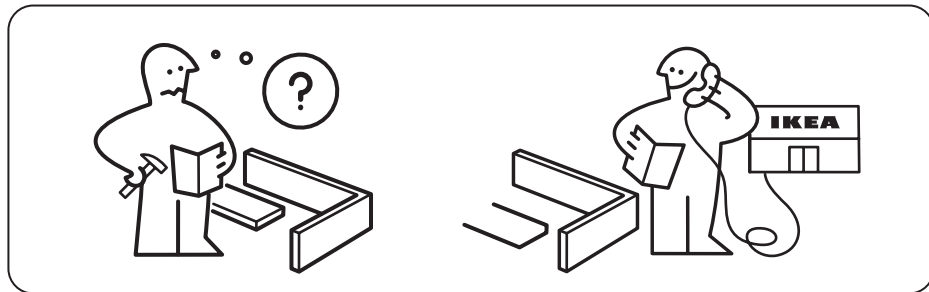
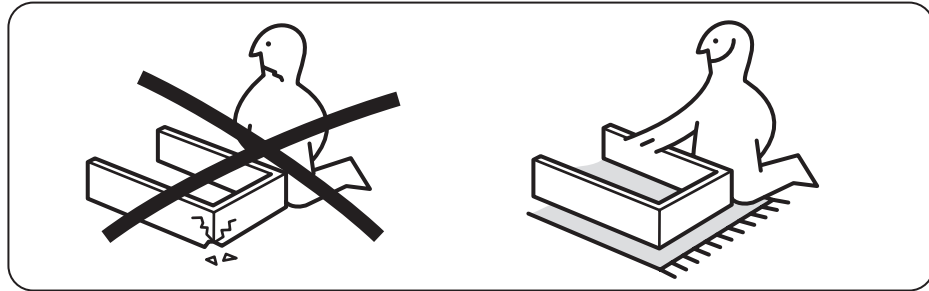
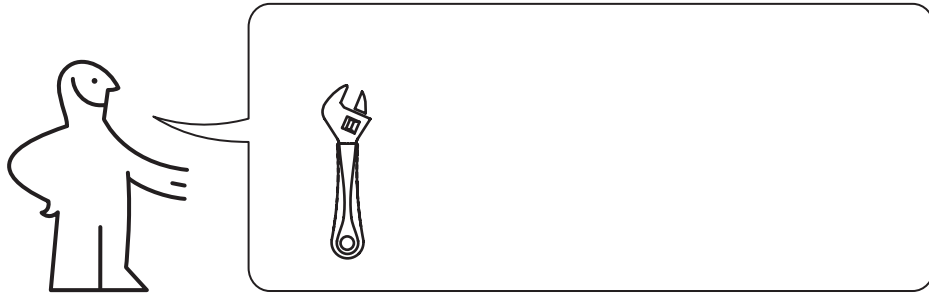

1x



22x



6x

1

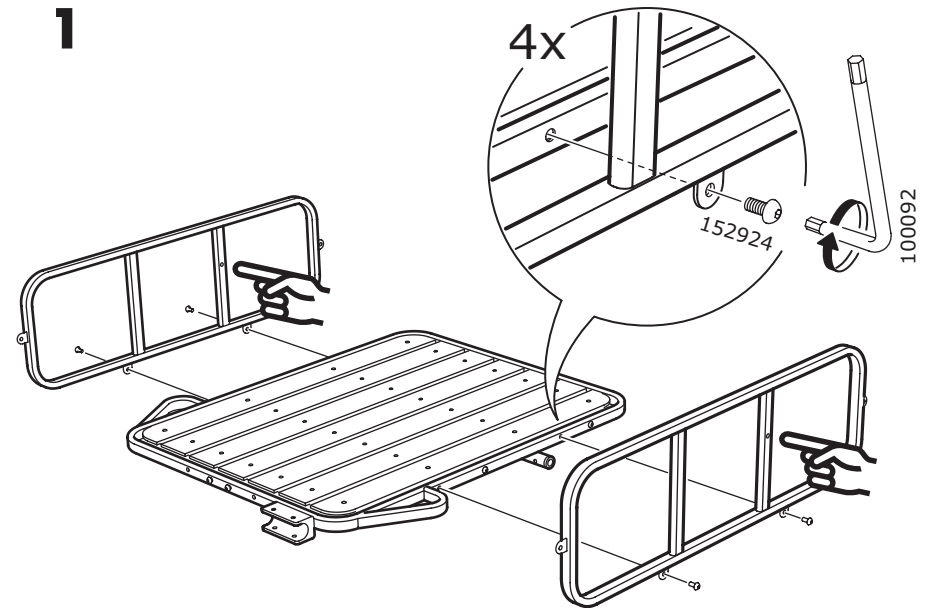

2

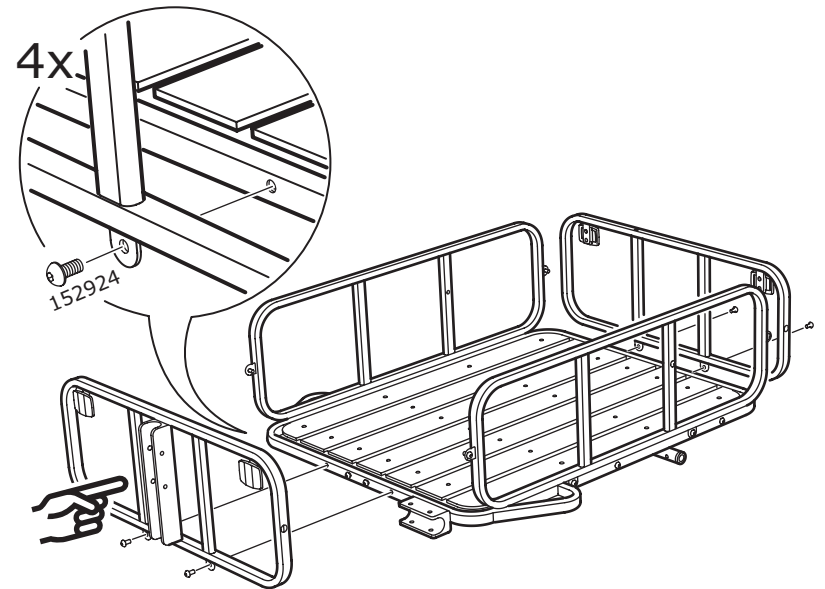

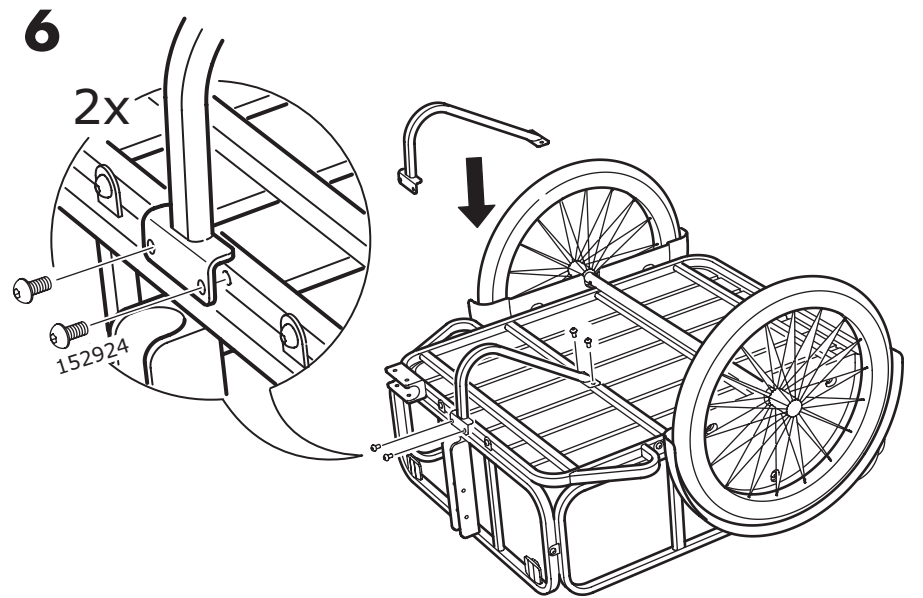
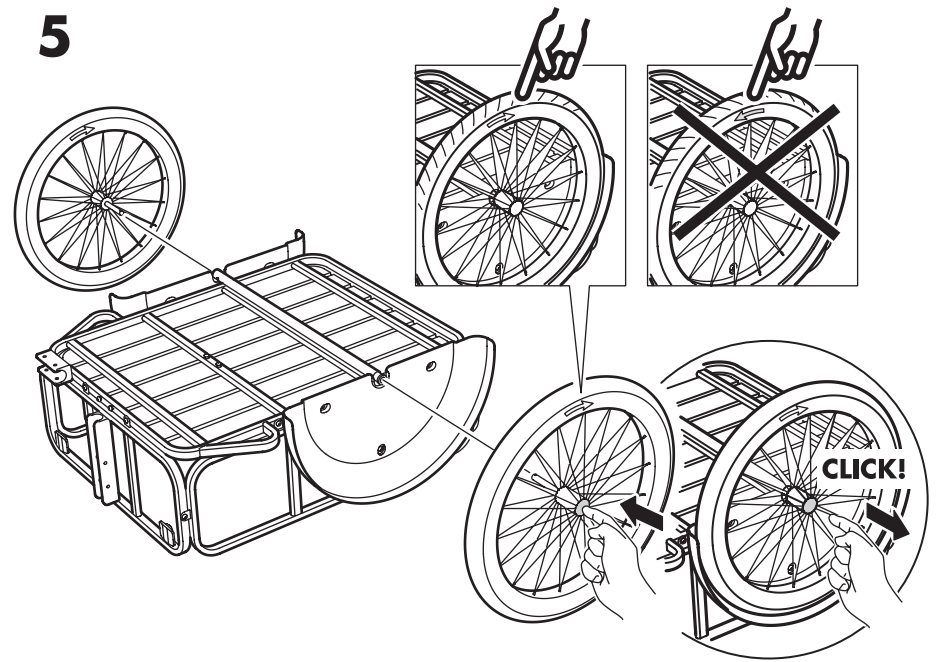
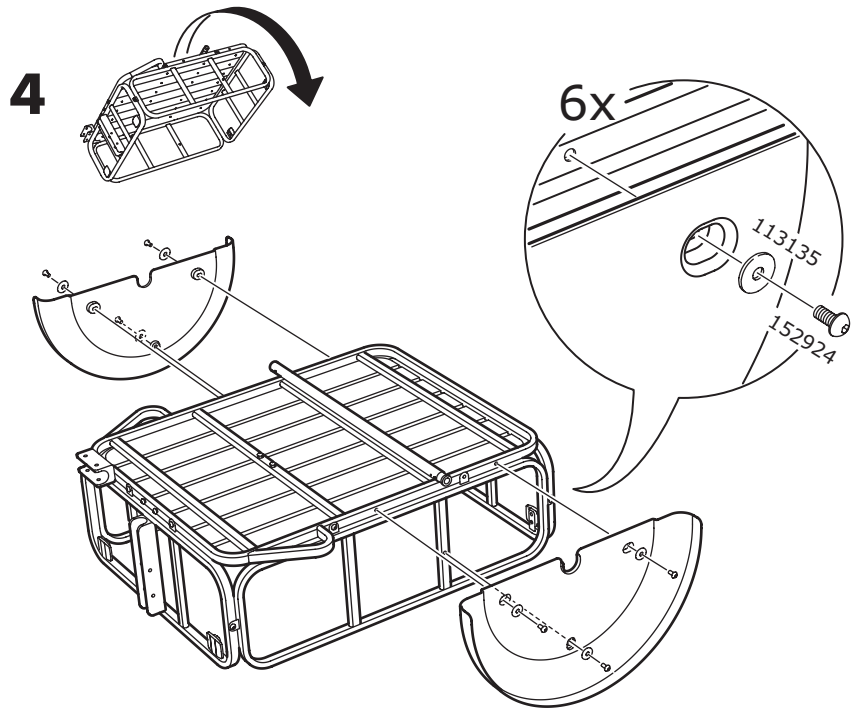
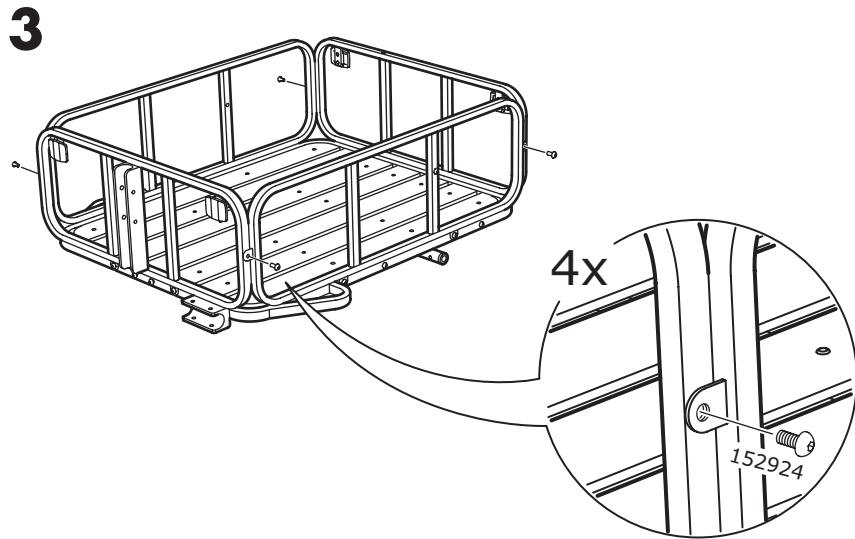

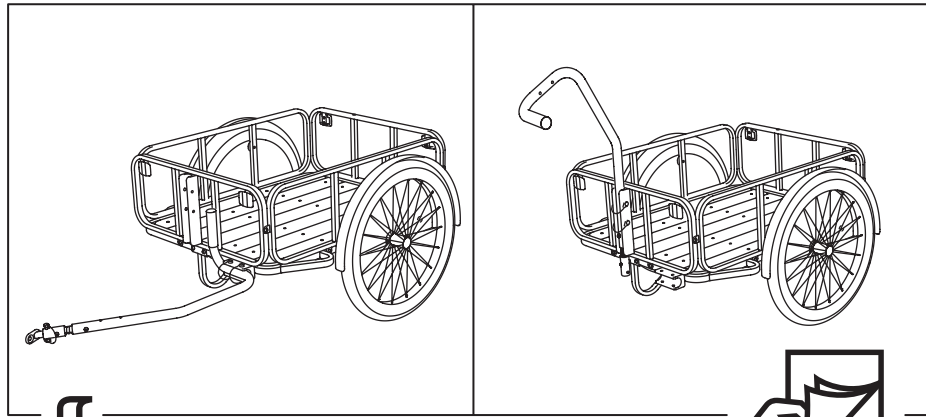

7

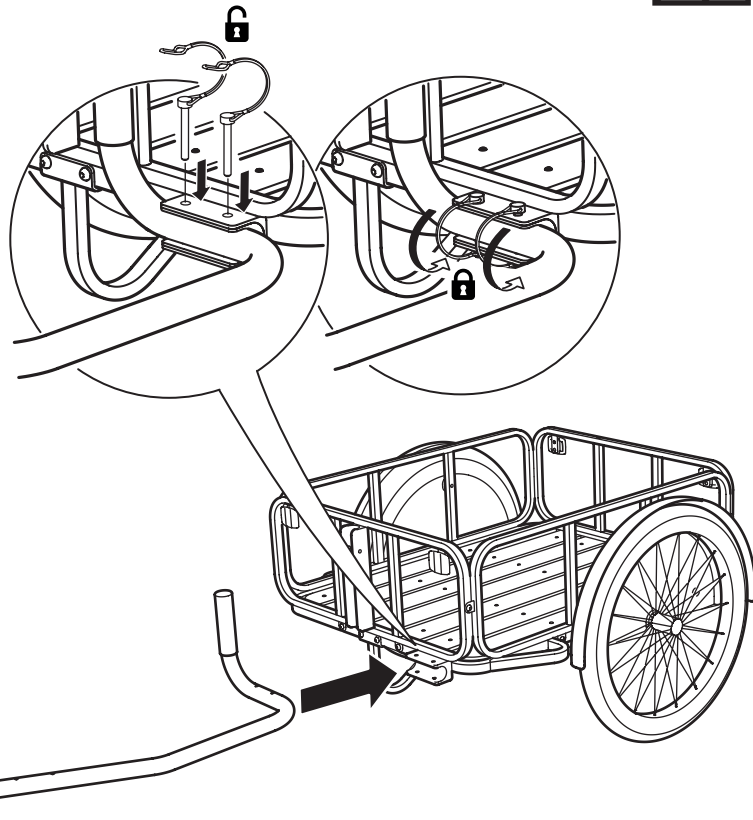

8

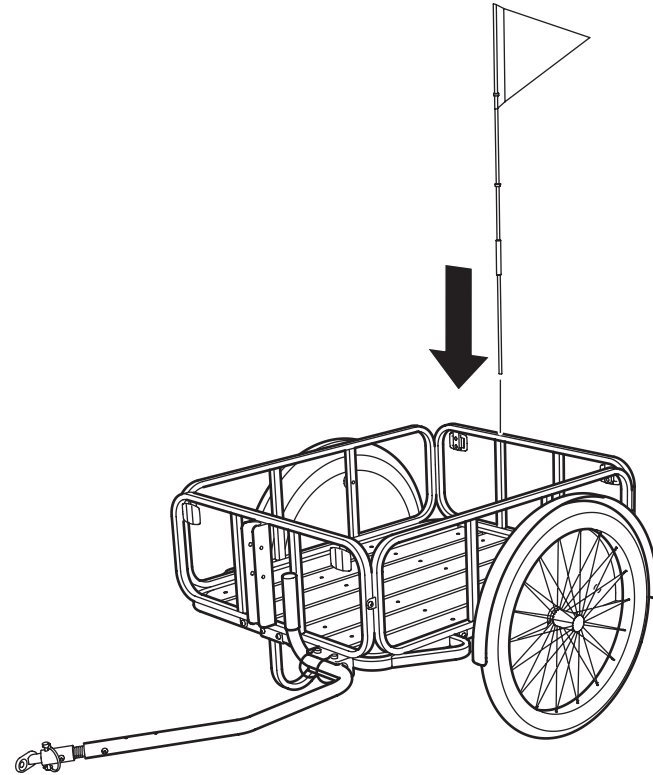

9

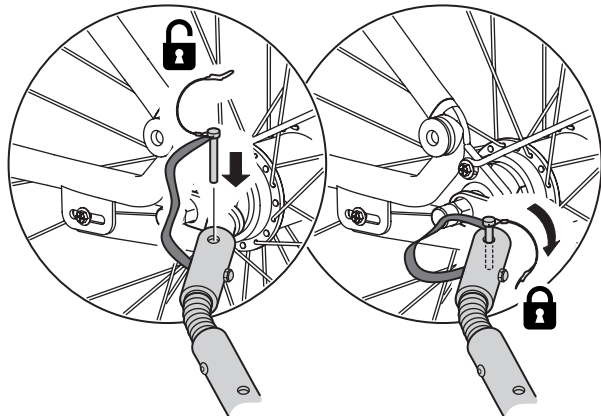
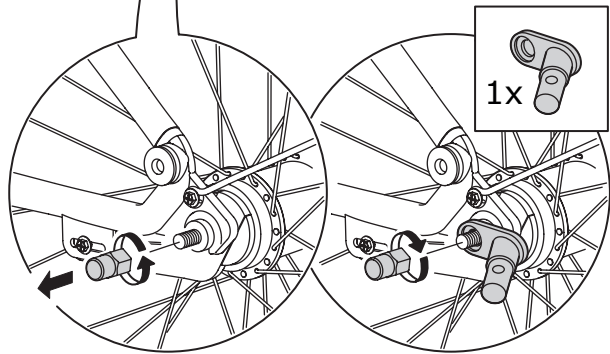
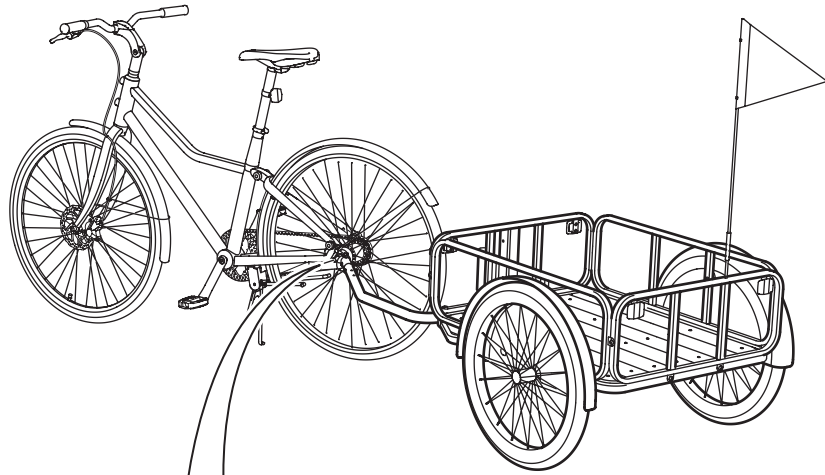

10

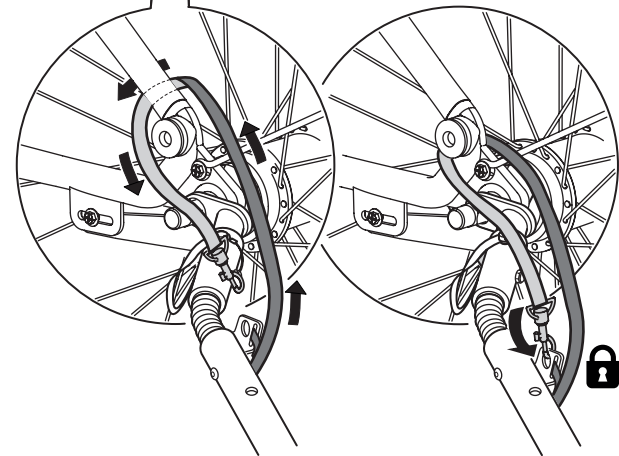
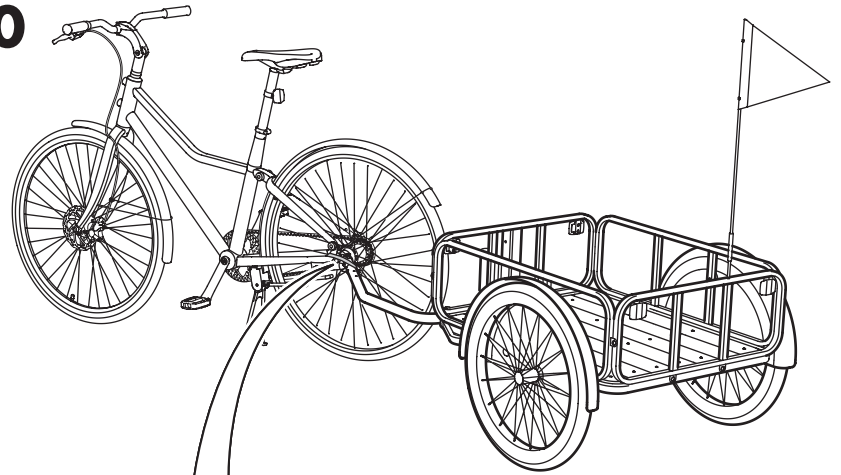

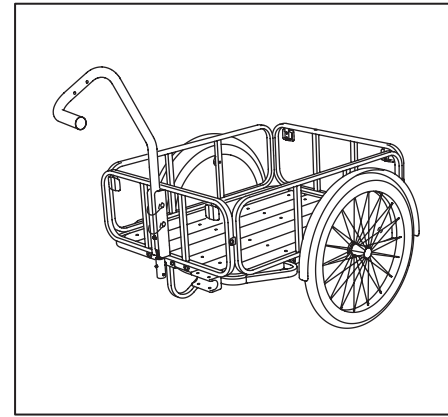
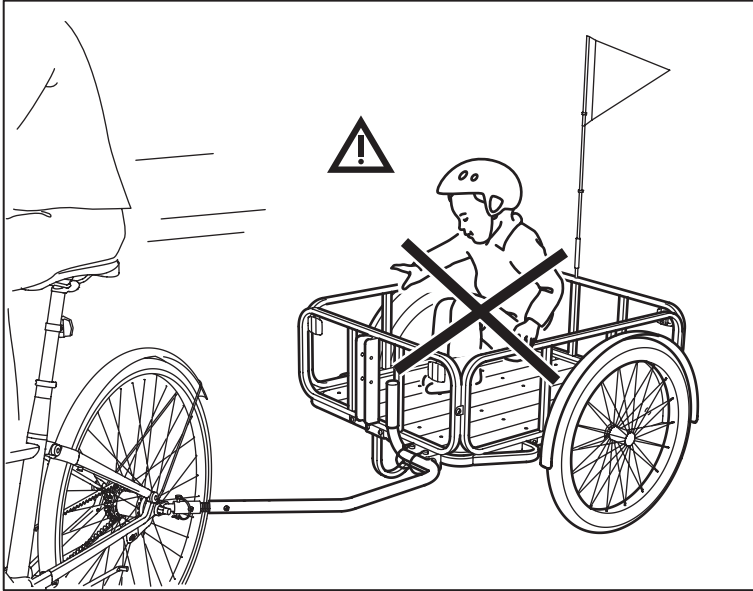

7

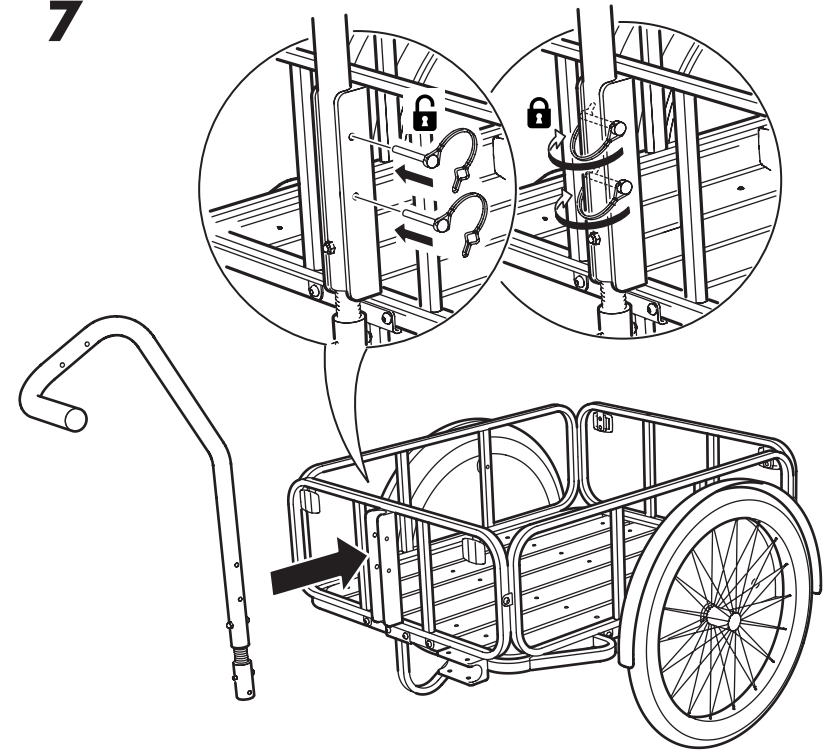

8

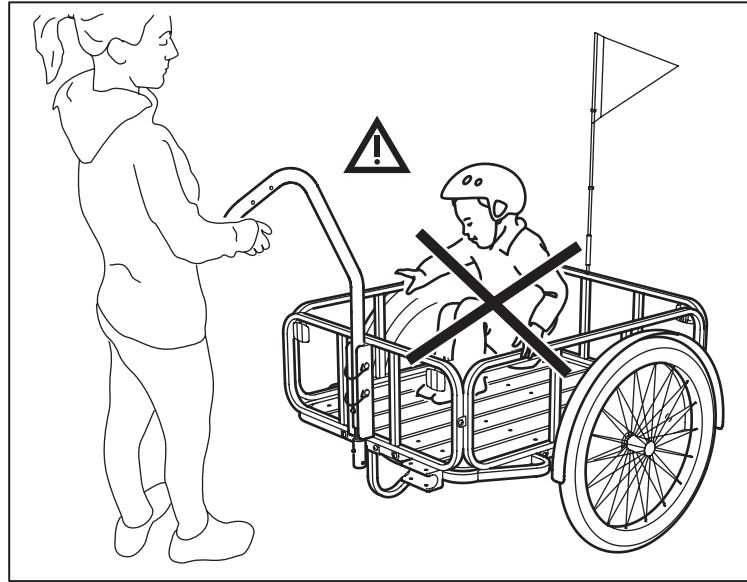
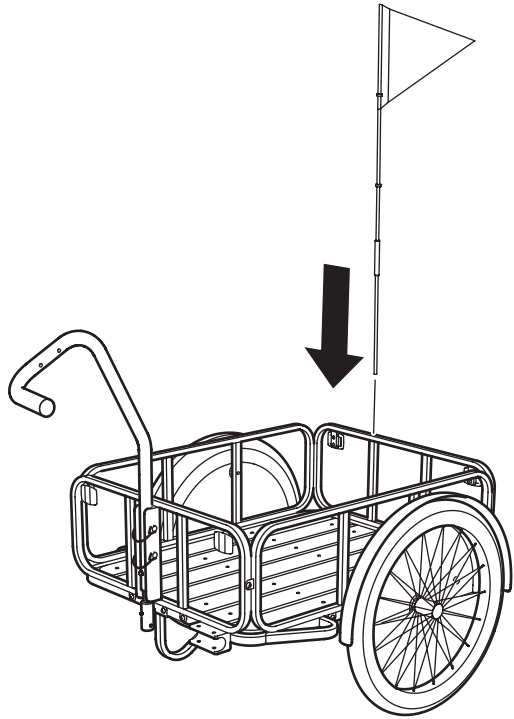

6. PYÖRÄN TESTAAMINEN ENNEN KÄYTTÖÄ

Ennen peräkärryn ottamista käyttöön sille kannattaa tehdä turvallisuustarkistus tasaisella maalla ja poissa liikenteen tieltä. On tärkeää tarkistaa, että kaikki osat on kiinnitetty ja ne toimivat oikein.

TARKISTA RENKAAT

Make sure that the tyres are inflated to the Täytä renkaat käyttäen pyöränpumppua, jossa on mittari. Paine ei saa ylittää pyöränkumis- sa ilmoitettua rajaa. Täyttämiseen kannattaa käyttää vain käsi- tai jalkakäyttöistä pumppua, ei huoltoaseman automaattista pumppua, sillä ylitäyttö voi puhkaista renkaan.

TARKISTA HEIJASTIMET

Varmista, että heijastimet ovat asianmukaisesti paikoillaan.



VAROITUS! *Kuten mitkä tahansa mekaaniset osat, myös pyörän osat ovat kovan kulutuksen myötä alttiita kulumiselle ja vaurioille. Erilaiset materiaalit ja osat reagoivat kuormitukseen eri tavoin. Jos jokin osa alkaa olla käyttökänsä päässä, se voi äkkiä pettää ja mahdollisesti aiheuttaa pyöräilijän loukkaantumisen. Halkeamat, kulumat ja värimuutokset kohdissa, joihin kohdistuu kova kuormitus, kertovat, että osan käyttöikä alkaa olla lopussa ja se täytyy vaihtaa uuteen.*

SVENSKA

INNEHÅLL

1. VARNING	31
2. SÄKERHET	31
3. SKÖTSEL OCH UNDERHÅLL	31
4. SLÄPETS DELAR OCH KOMPONENTER	32
5. MONTERA DITT SLÄP	33
6. TESTA DITT SLÄP FÖRE ANVÄNDNING	39

1. VARNING



- **Varning!** Bromssträckan blir längre när du cyklar med släp.
- Passar cykeln SLADDA 26" och 28".
- **NOTERA!** Om du vill använda släpet med en annan cykel behöver du kontrollera i cykelns manual om fästansordningen passar och vilket typ av släp som är tillåtet. Obs – koppla aldrig släpet till en mountainbike, racercykel, elcykel eller annan cykel med hjälpmotor.
- Släpet SLADDA är inte lämpligt för transport av barn eller djur. Följ manualen för att montera och använda släpet på ett korrekt och säkert sätt.

2. SÄKERHET

För din säkerhet, följ alltid de trafikregler som gäller i ditt land.

3. SKÖTSEL OCH UNDERHÅLL

Kontrollera regelbundet släpets delar, såsom monteringskruvar, fästansordningar, ram, reflexer och däck.

IKEA of Sweden AB
34381 Älmhult
Sweden

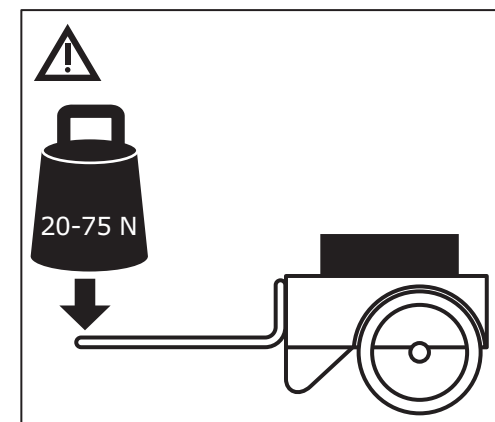
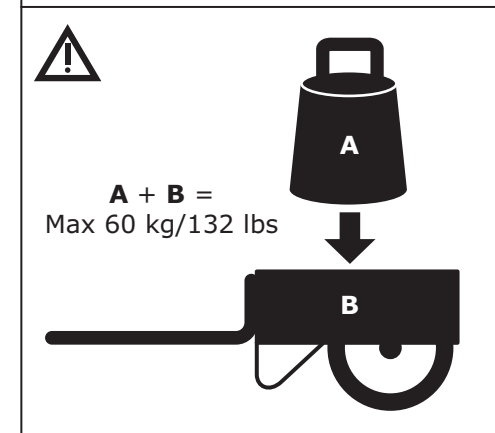
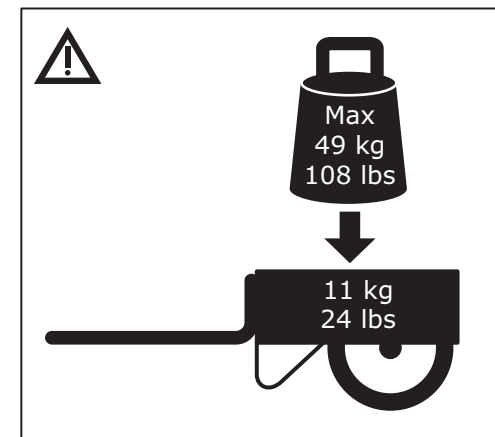

4. SLÄPETS DELAR OCH KOMPONENTER

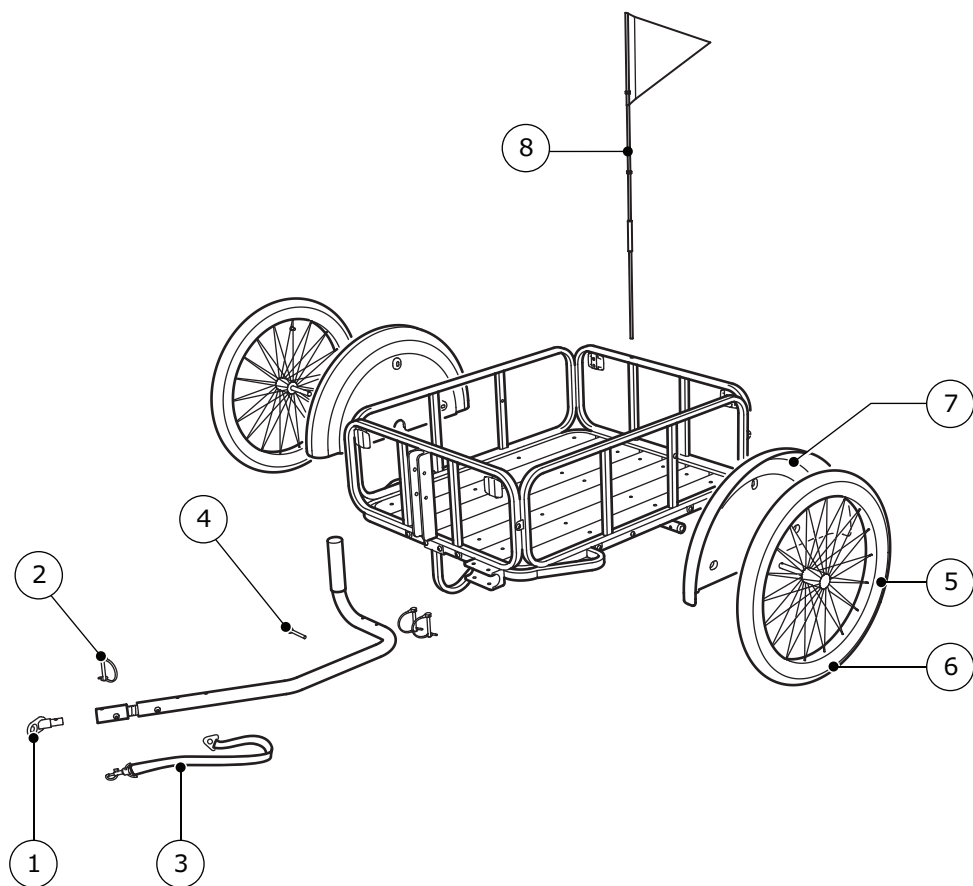

- 1 Koppling (152921)
- 2 Låsbar sprint (152922)
- 3 Säkerhetsrem (152923)
- 4 Skruv (152924)
- 5 Hjul, däck och innerslang (152925)
- 6 Däck (152926)
- 7 Stänkskärm (152927)
- 8 Flagga (192282)

5. MONTERA DITT SLÄP

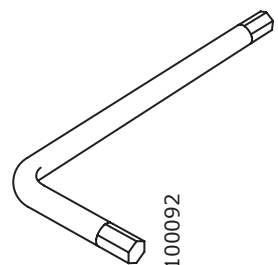
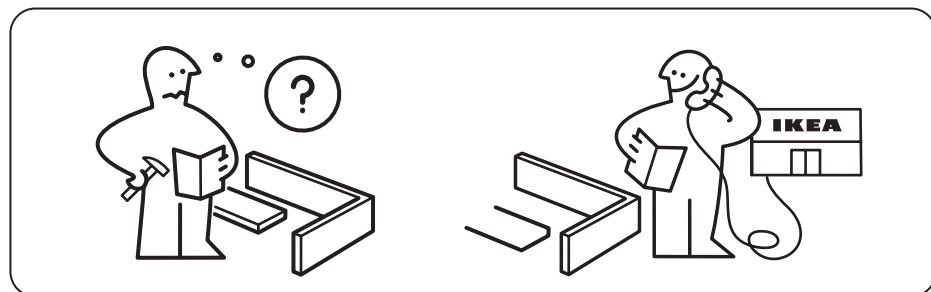
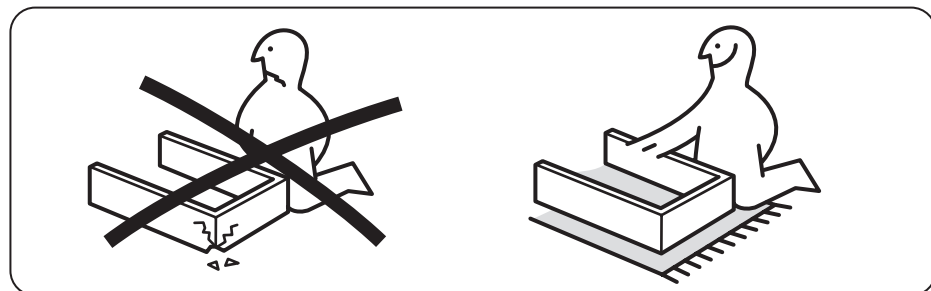
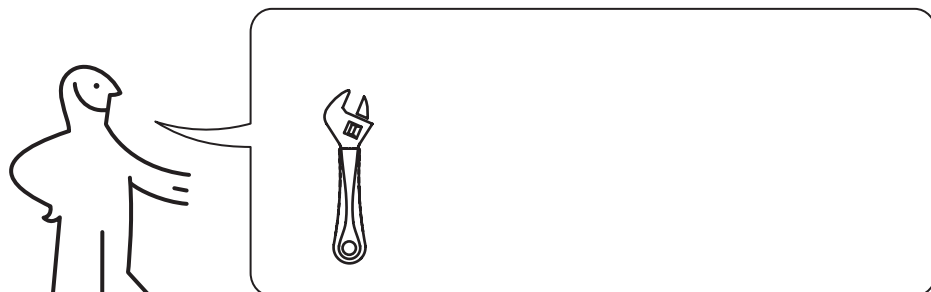

1x

100092

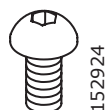

22x

152924



6x

113135

1

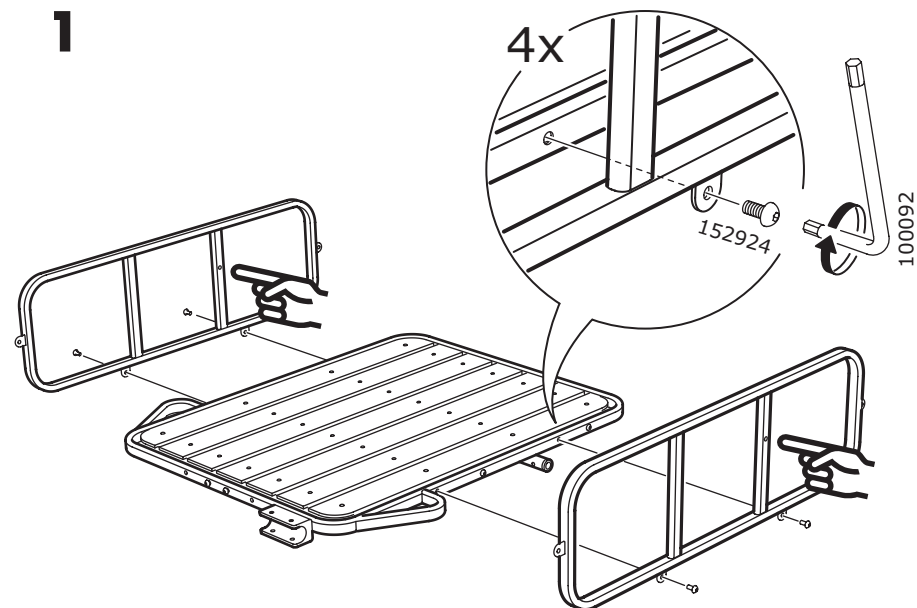

2

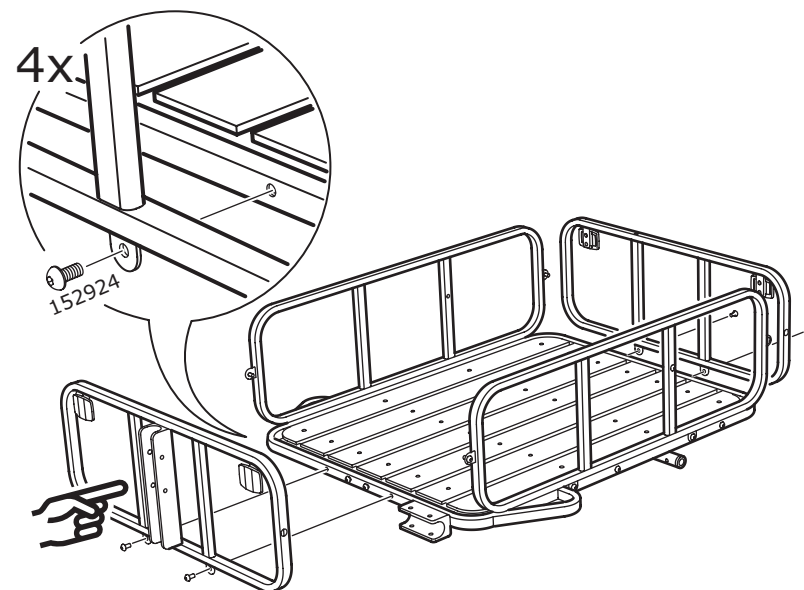

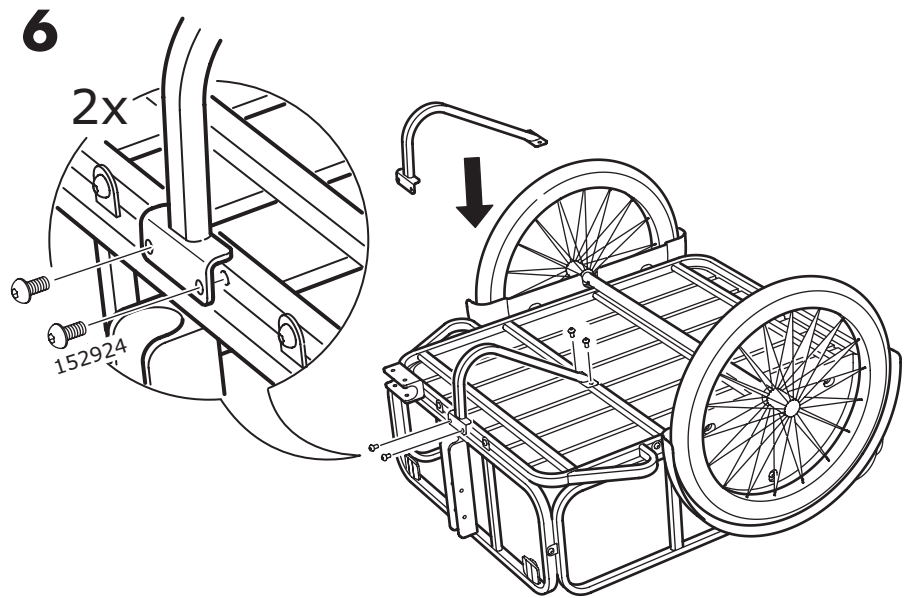
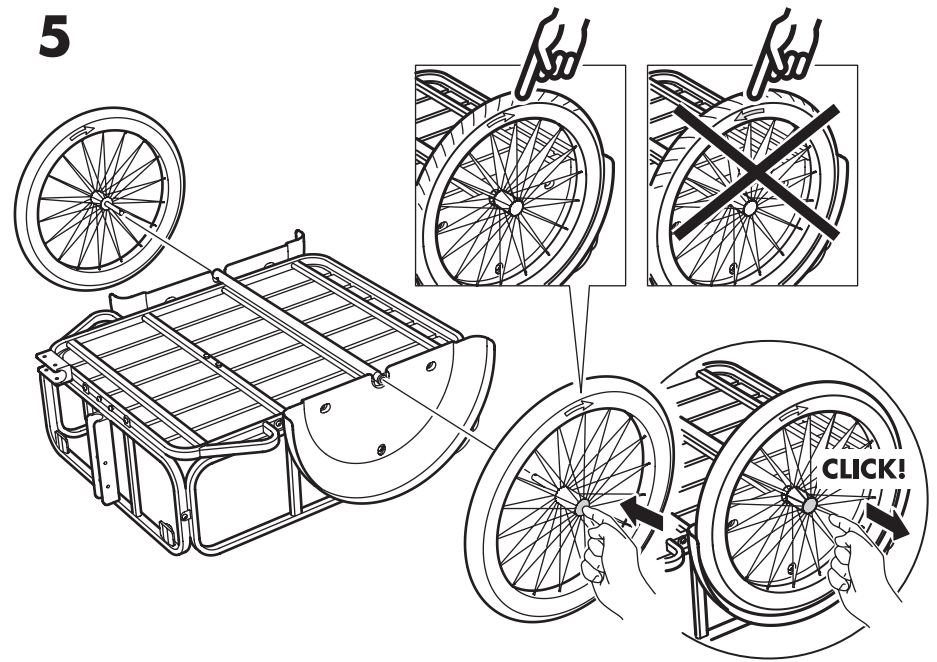
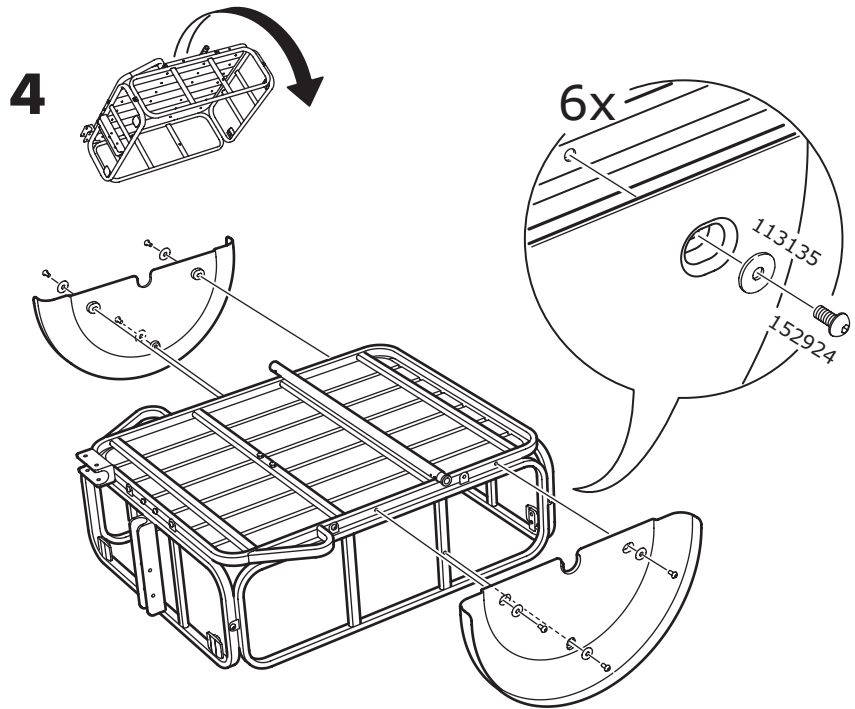
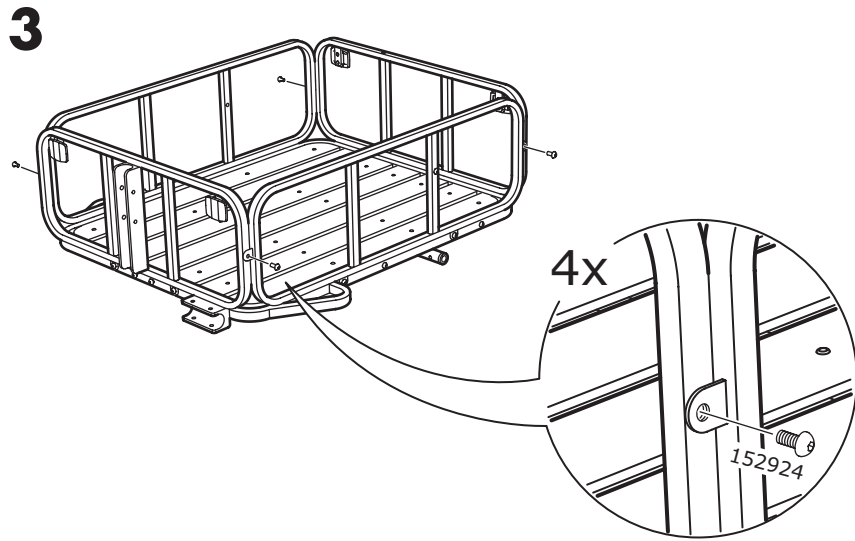

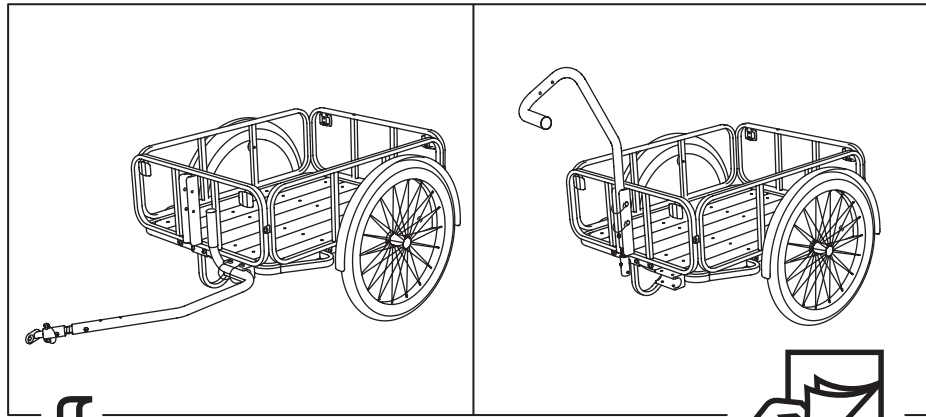

7

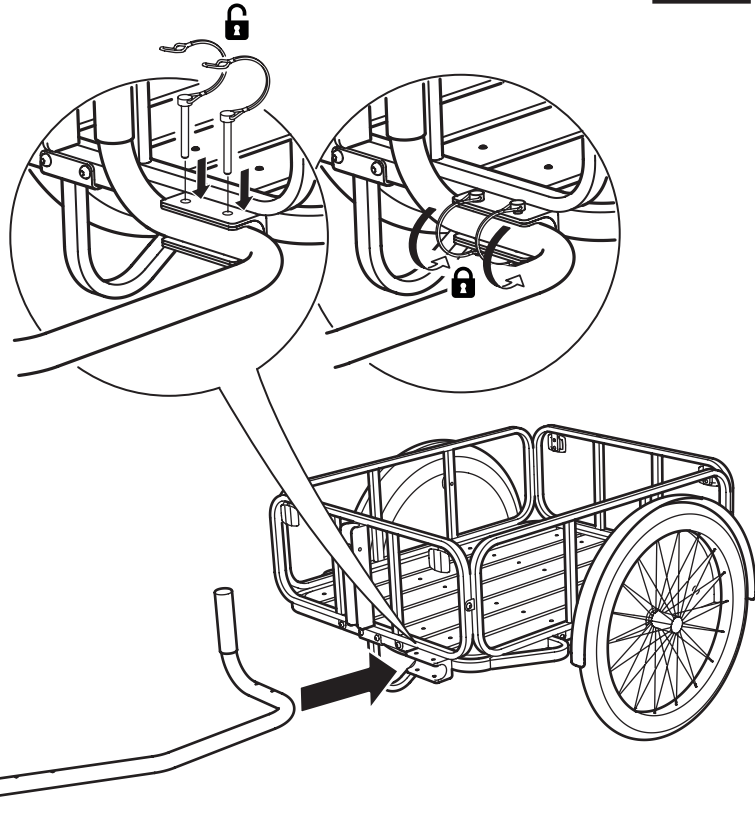

8

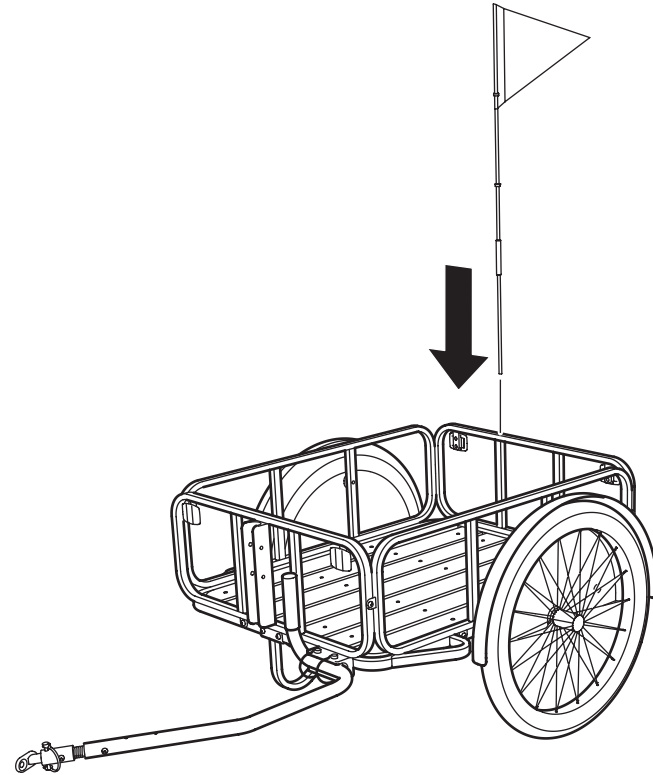

9

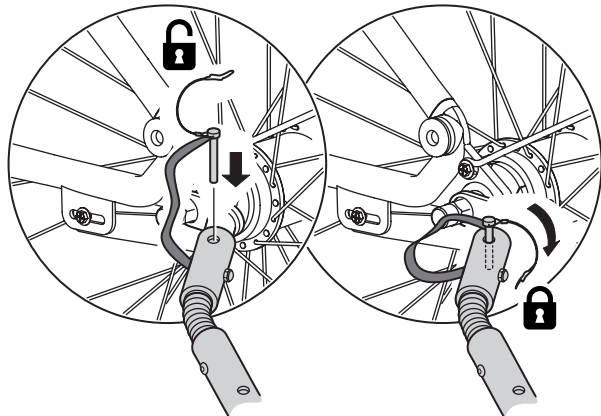
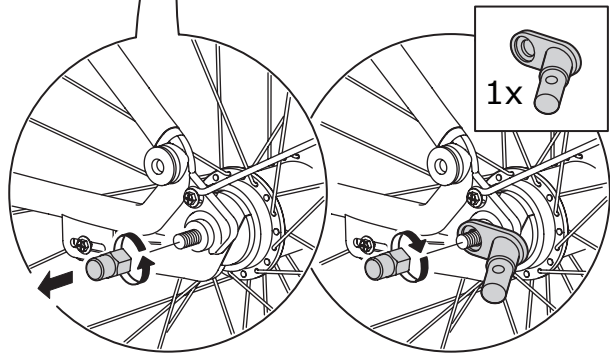
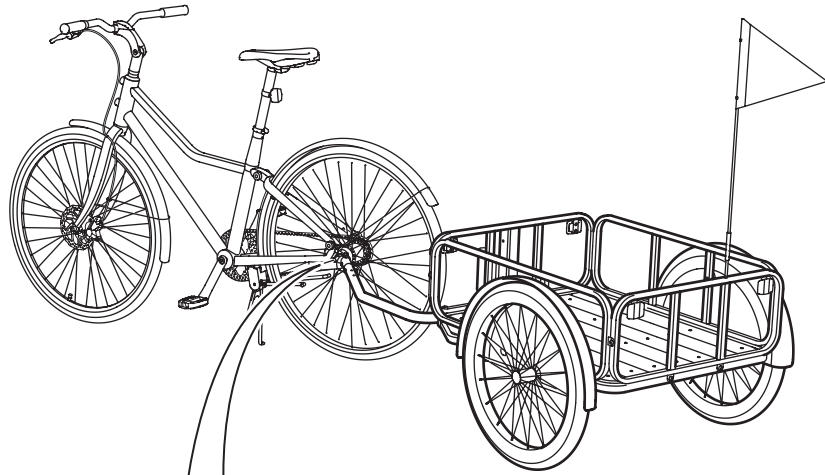

10

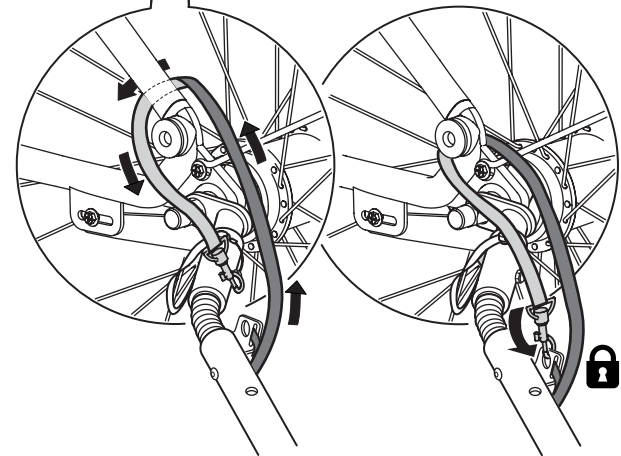
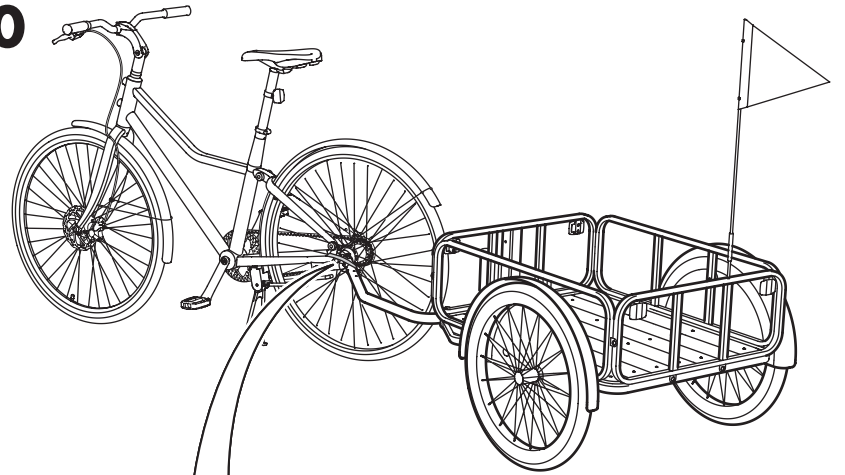

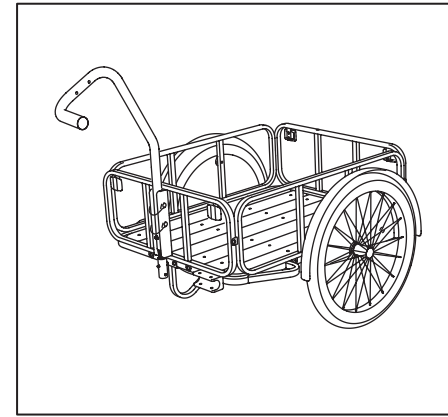
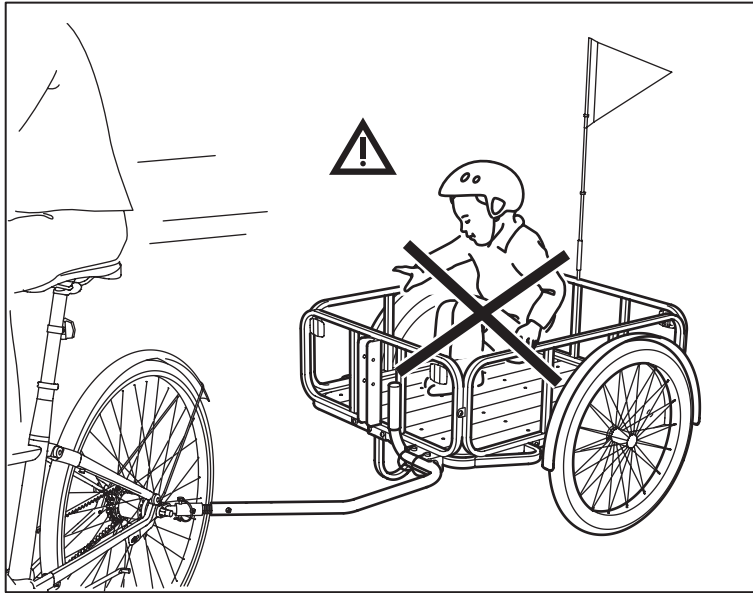

7

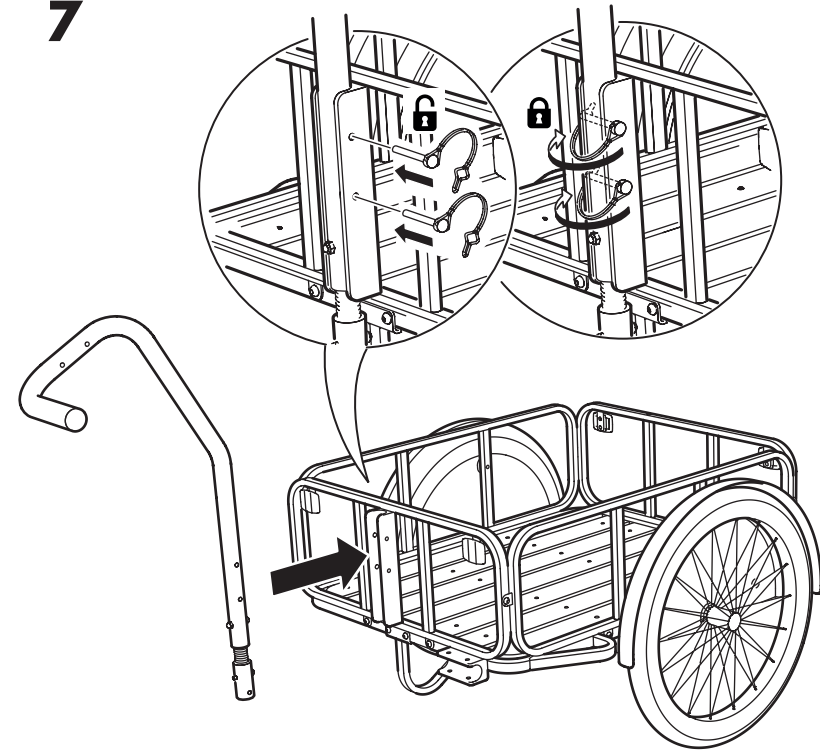

8

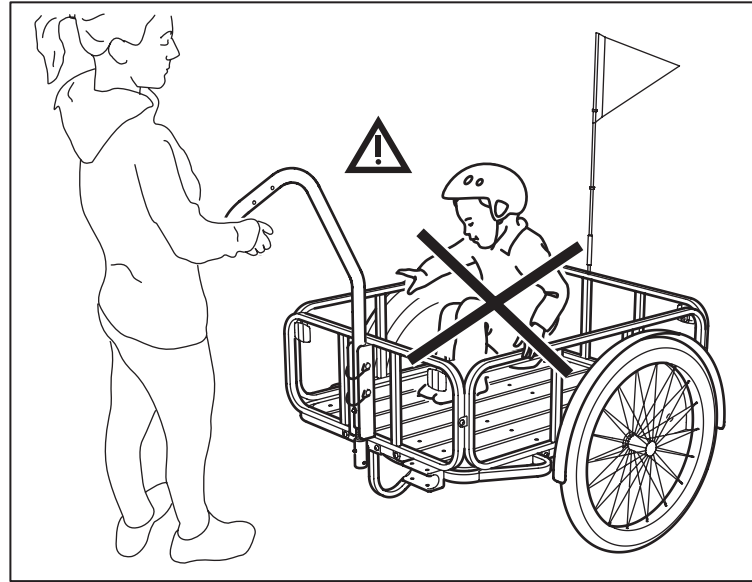
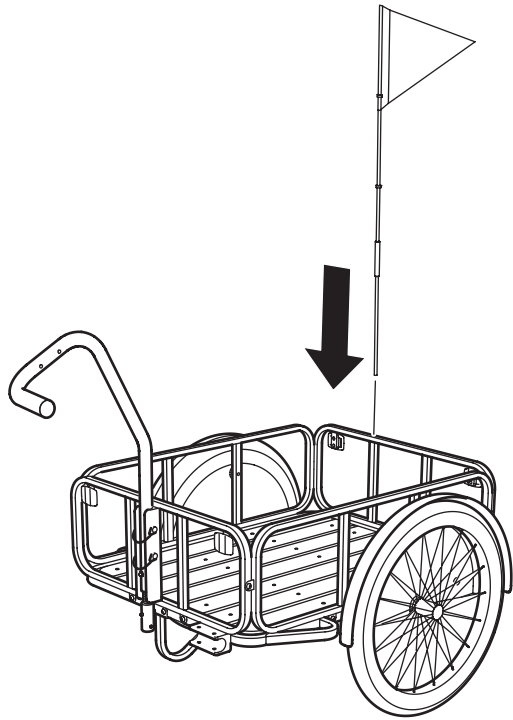

6. TESTA DITT SLÄP FÖRE ANVÄNDNING

Innan du använder ditt släp ska du göra en säkerhetstest på en plats med plan mark och lite trafik. Det är viktigt att du är säker på att alla delar sitter fast ordentligt och fungerar som de ska.

KONTROLLERA DÄCKEN

Kontrollera att däcken är lagom pumpade genom att använda en cykelpump med tryckmätare. Trycket ska inte överskrida den rekommenderade gräns som finns angiven på däckets. Det är bättre att använda en manuell hand- eller fotpump än en automatisk pump, eftersom däckets kan explodera om du pumpar det för mycket.

KONTROLLERA REFLEXER

Kontrollera att alla reflexer sitter i rätt position.



WARNING! Ditt släp kommer att utsättas för slitage och påfrestningar, precis som all annan utrustning med mekaniska komponenter. Material och delar kan reagera på olika sätt på slitage. Om livslängden på en komponent har gått ut kan den plötsligt sluta fungera och orsaka skador på den som cyklar. Sprickor, repor eller färgförändringar på hårt belastade områden kan tyda på att komponentens livslängd är slut och att den behöver bytas ut.

