

FRILLESBO

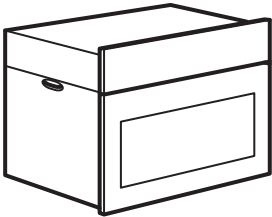

Design and Quality
IKEA of Sweden

ENGLISH	5
DEUTSCH	9
FRANÇAIS	13
ITALIANO	17

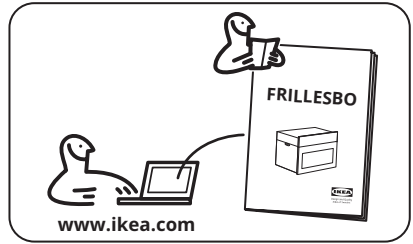
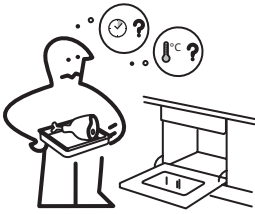

1x

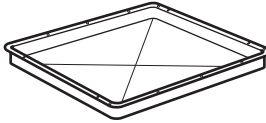

1x



1x

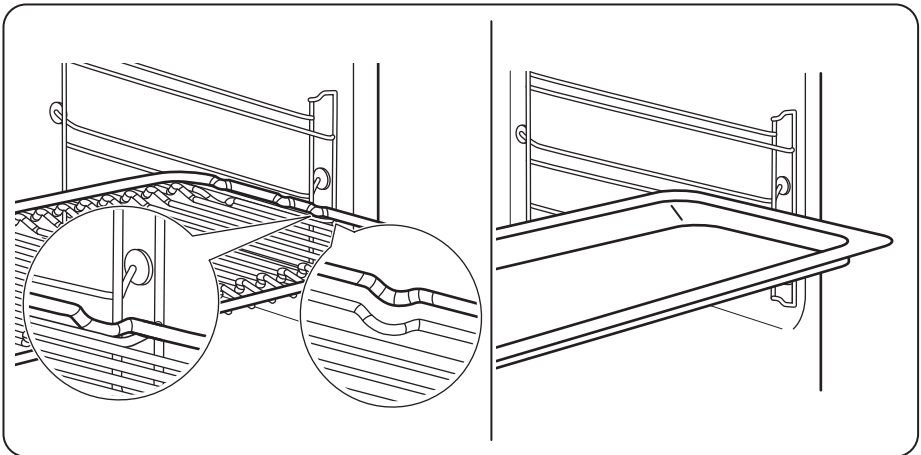

Product description

General overview

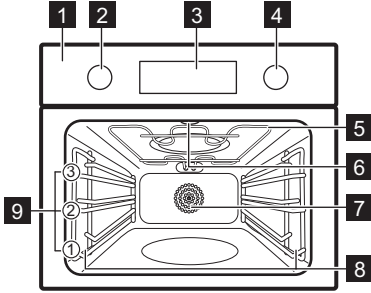

- 1 Control panel
- 2 Knob for the heating functions
- 3 Display
- 4 Control knob
- 5 Heating element
- 6 Lamp
- 7 Fan
- 8 Shelf support, removable
- 9 Shelf positions

Control panel

Turning the appliance on and off

To turn on the appliance:

1. Press the knobs. The knobs come out.
2. Turn the knob for the heating functions to select a function.
3. Turn the control knob to adjust settings.

To turn off the appliance: turn the knob for the heating functions to the off position **0**.

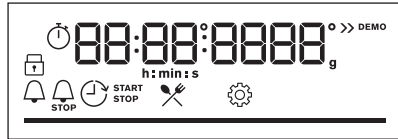

Control panel overview

	Press to set timer functions.
	Press and hold to set the function: Fast Heat Up.
	Press to turn the appliance lamp on and off.
	Press and hold to set the function: Lock.
	Press to confirm your selection.









	The appliance is locked.
	Submenu: Assisted Cooking.
	Submenu: Settings
	Fast Heat Up is activated.
	Minute minder is activated.
	Cooking time is activated.
	Time Delayed Start is activated.
	Uptimer is activated.
	Progress bar - visually indicates when the appliance reaches the set temperature or when the cooking time comes to an end.

Display indicators

Display with key functions:

Daily use

Heating functions

	True Fan Cooking: Even baking, tenderness, drying
	Conventional Cooking: Traditional baking
	Frozen Foods: French fries, potato wedges, spring rolls
	Pizza Function: Baking pizza
	Bottom Heat: Baking cakes
	Defrost: Defrosting
	Moist Fan Baking: Baking
	Grill: Toasting, grilling
	Turbo Grilling: Roasting meat, browning

The lamp may turn off automatically at a temperature below 80°C during some oven functions.

Notes on: Moist Fan Baking

This function was used to comply with the energy efficiency class and ecodesign requirements (according to EU 65/2014 and EU 66/2014). Tests according to: IEC/EN 60350-1.

The oven door should be closed during cooking so that the function is not interrupted and the oven operates with the highest energy efficiency possible.



When you use this function the lamp automatically turns off after 30 sec.

This function is designed to save energy during cooking. When you use this function, the temperature in the cavity may differ from the set temperature. The heating power may be reduced.

Entering: Menu



Open the Menu to access Assisted Cooking dishes and settings.























1. Turn the knob for the heating functions to .































The display shows , .











2. Turn the control knob and select the icon to enter submenu. Press **OK**.

Submenu: Assisted Cooking

Legend	
	Weight adjustment available.
	Preheat the appliance before you start cooking.
	Shelf level. Refer to Product description.

P1	Roast beef, rare  2
P2	Roast beef, medium  2
P3	Roast beef, well-done  2
P4	Steak, medium  2
P5	Beef roast / braised   1
P6	Roast beef, rare LTC*  2
P7	Roast beef, medium LTC*  2
P8	Roast beef, well-done LTC*  2
P9	Fillet, rare  2
P10	Fillet, medium  2
P11	Fillet, well-done  2
P12	Veal roast   1
P13	Pork roast (e.g. neck or shoulder)  1
P14	Pulled pork  2
P15	Pork loin, fresh  1
P16	Spare ribs  2
P17	Lamb leg with bones  1
P18	Chicken, whole  1
P19	Chicken, half   2
P20	Chicken breast  2

P21	Chicken legs, fresh  2
P22	Duck, whole   1
P23	Goose breast  2
P24	Meat loaf  1
P25	Fish, whole, grilled  2
P26	Fish fillet   3
P27	Cheesecake  3
P28	Apple cake, covered   2
P29	Apple tart  2
P30	Apple pie   2
P31	Brownies   2
P32	Muffins   2
P33	Loaf cake  1
P34	Baked potatoes   2
P35	Wedges   2
P36	Grilled mixed vegetables  2
P37	Croquettes, frozen   2
P38	French fries   2
P39	Lasagna with dry pasta sheets   1

P40	Potato gratin  1
P41	Pizza fresh, thin crust   1
P42	Pizza fresh, thick crust   1
P43	Quiche lorraine   1
P44	Baguette / Ciabatta / White bread   2
P45	Whole grain / Rye / Dark bread   1

*LTC - Low Temperature Cooking

Submenu: Settings

	Setting	Value
01	Time of day	Change
02	Display brightness	1 - 5
03	Key tones	1 - Beep, 2 - Click, 3 - Sound off
04	Buzzer volume	1 - 4
05	Uptimer	On / Off
06	Light	On / Off
07	Fast Heat Up	On / Off
08	Demo mode	-
09	Software version	Check
10	Reset all settings	Yes / No

Troubleshooting

If you encounter an issue with your appliance, check Troubleshooting in the full

version of the User Manual available on: www.ikea.com.

Energy efficiency

Product information sheet and product information according to EU energy labelling and ecodesign regulations

Supplier's name	IKEA
Model identification	FRILLESBO 506.140.73
Energy efficiency index	80.8

Energy efficiency class	A+
Energy consumption with a standard load, conventional mode	0.99 kWh/cycle
Energy consumption with a standard load, fan-forced mode	0.59 kWh/cycle
Number of cavities	1
Heat source	Electricity
Volume	43 l
Type of oven	Built-in oven
Mass	33.6 kg

Product information for power consumption and maximum time to reach applicable low power mode

Power consumption in standby	0.8 W
Maximum time needed for the equipment to automatically reach the applicable low power mode	20 min

Gerätebeschreibung

Gesamtansicht

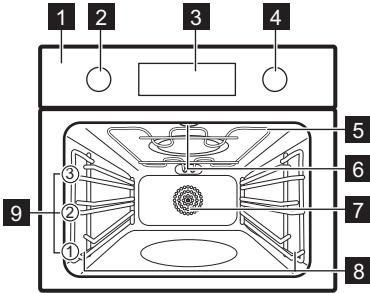

- 1 Bedienfeld
- 2 Einstellknopf für die Ofenfunktionen
- 3 Display
- 4 Einstellknopf
- 5 Heizelement
- 6 Lampe
- 7 Ventilator
- 8 Einschubschienen, herausnehmbar
- 9 Einschubebenen

Bedienfeld

Ein- und Ausschalten des Geräts

Einschalten des Geräts:

1. Drücken Sie die Knöpfe. Die Knöpfe treten heraus.
2. Drehen Sie den Knopf für die Ofenfunktionen zur Auswahl einer Funktion.
3. Drehen Sie den Bedienknopf, um die Einstellungen zu ändern.

Ausschalten des Geräts: Drehen Sie den Knopf für die Ofenfunktionen in die Aus-Position 0.

Überblick - Bedienfeld

	Drücken Sie, um die Timer-Funktionen einzustellen.
	Halten Sie die Taste gedrückt, um die Funktion einzustellen: Schnellaufheizung.
	Drücken Sie, um die Gerätelampe ein- und auszuschalten.
	Halten Sie die Taste gedrückt, um die Funktion einzustellen: Verriegelung.
OK	Zur Bestätigung der Auswahl drücken.

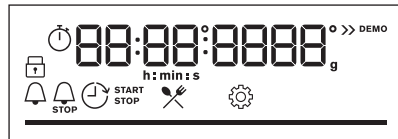









	Das Gerät ist verriegelt.
	Untermenü: Koch-Assistent.
	Untermenü: Einstellungen
	Schnellaufheizung ist eingeschaltet.
	Kurzzeit-Wecker ist eingeschaltet.
	Garzeit ist eingeschaltet.
	Zeit Zeitvorwahl ist eingeschaltet.
	Uptimer ist eingeschaltet.
	Fortschrittsbalken - Zeigt visuell an, wann das Gerät die eingestellte Temperatur erreicht oder die Garzeit beendet ist.

Display-Anzeigen

Display mit Tastenfunktionen:

Täglicher Gebrauch

Ofenfunktionen

	Heißluft: Gleichmäßiges Backen, Zartheit, Dörren
	Ober- / Unterhitze: Traditionelles Backen
	Tiefkühlgerichte: Pommes frites, Kartoffelspalten, Frühlingsrollen
	Pizzastufe: Backen von Pizza
	Unterhitze: Kuchen backen
	Auftauen: Auftauen
	Feuchte Umluft: Backen
	Grill: Toasten, Grillen
	Heißluftgrillen: Braten von Fleisch, Bräunen

Die Lampe wird bei einigen Ofenfunktionen und einer Temperatur unter 80 °C automatisch ausgeschaltet.

Hinweise zu: Feuchte Umluft

Diese Funktion wurde zur Einhaltung der Energieeffizienzklasse und der Ökodesign-Anforderungen (gemäß EU 65/2014 und EU 66/2014) verwendet. Tests gemäß: IEC/EN 60350-1.

Die Backofentür sollte während des Garvorgangs geschlossen bleiben, damit die Funktion nicht unterbrochen wird. So wird gewährleistet, dass der Backofen mit der höchsten Energieeffizienz arbeitet.

Wenn Sie diese Funktion verwenden, schaltet sich die Backofenbeleuchtung automatisch nach 30 Sekunden aus.



Diese Funktion ist entwickelt worden, um während des Kochvorgangs Energie zu sparen. Wenn Sie diese Funktion nutzen, kann die Temperatur im Garraum von der eingestellten Temperatur abweichen. Die Wärmeleistung kann geringer sein.

















Eingabe: Menü ☰































Öffnen Sie das Menü, um auf Gerichte mit dem Koch-Assistenten und auf Einstellungen zuzugreifen.

















1. Drehen Sie den Knopf für die Ofenfunktionen auf ☰. Auf dem Display wird  angezeigt.
2. Drehen Sie den Bedienknopf und wählen Sie das Symbol, um in das Untermenü zu gelangen. Drücken Sie OK.

Untermenü: Koch-Assistent

Legende	
	Gewichtsanpassung verfügbar.
	Heizen Sie das Gerät auf, bevor Sie mit dem Kochen beginnen.
	Einschubebene. Siehe Gerätebeschreibung.

P1	Roastbeef, blutig  2
P2	Roastbeef, rosa  2
P3	Roastbeef, durch  2
P4	Steak, rosa  2
P5	Rinderbraten / geschmort   1
P6	Roastbeef, blutig LTC*  2
P7	Roastbeef, rosa LTC*  2
P8	Roastbeef, durch LTC*  2
P9	Filet, blutig  2
P10	Filet, rosa  2
P11	Filet, durch  2
P12	Kalbsbraten   1
P13	Schweinebraten (z. B. Hals oder Schulter)  1
P14	Pulled Pork  2

P15	Schweinelende, frisch  1
P16	Spareribs  2
P17	Lammkeule mit Knochen  1
P18	Hähnchen, ganz  1
P19	Hähnchen, halbiert   2
P20	Hähnchenbrust  2
P21	Hähnchenschengel, frisch  2
P22	Ente, ganz   1
P23	Gänsebrust  2
P24	Hackbraten  1
P25	Fisch, ganz, gegrillt  2
P26	Fischfilet   3
P27	Käsekuchen  3
P28	Apfelkuchen, gedeckt   2
P29	Apfel-Tarte  2
P30	Apfelkuchen   2
P31	Brownies   2
P32	Muffins   2
P33	Laibkuchen  1
P34	Ofenkartoffeln   2
P35	Kartoffelspalten   2
P36	Gemischtes gegrilltes Gemüse  2

P37	Kroketten, gefroren   2
P38	Pommes frites   2
P39	Lasagne mit trockenen Nudelblättern   1
P40	Kartoffelgratin  1
P41	Pizza frisch, dünne Kruste   1
P42	Pizza frisch, dicke Kruste   1
P43	Quiche Lorraine   1
P44	Baguette / Ciabatta / Weißbrot   2
P45	Vollkorn- / Roggen- / dunkles Brot   1

* LTC – Niedertemperaturgaren

Untermenü: Einstellungen

	Einstellung	Wert
01	Uhrzeit	Ändern
02	Helligkeit	1 - 5
03	Tastentöne	1 – Piepton, 2 – Klicken, 3 – Ton aus
04	Lautstärke	1 - 4
05	Uptimer	Ein / Aus
06	Beleuchtung	Ein / Aus
07	Schnellaufheizung	Ein / Aus
08	Demo-Modus	-
09	Softwareversion	Prüfen
10	Gerät auf Werkseinstellungen zurücksetzen	Ja / Nein

Fehlerbehebung

Wenn Sie ein Problem mit Ihrem Gerät haben, lesen Sie das Kapitel Fehlerbehebung

in der Vollversion der Bedienungsanleitung, die hier verfügbar ist: www.ikea.com.

Energieeffizienz

**Produktinformationsblatt und die Produktinformationen für
Dunstabzugshaube gemäß EU-Energiekennzeichnungs- und
Ökodesignverordnungen**

Name des Lieferanten	IKEA
Modellbezeichnung	FRILLESBO 506.140.73
Energieeffizienzindex	80,8
Energieeffizienzklasse	A+
Energieverbrauch mit einer Standardbeladung, konventioneller Modus	0,99 kWh/Programm
Energieverbrauch mit einer Standardbeladung, Umluft-Modus	0,59 kWh/Programm
Anzahl der Garräume	1
Wärmequelle	Strom
Volumen	43 l
Art des Backofens	Eingebauter Backofen
Masse	33.6 kg

**Produktinformationen für Leistungsaufnahme und maximale Zeit bis zum
Erreichen des entsprechenden Energiesparmodus**

Leistungsaufnahme im Bereitschaftszustand	0.8 W
Maximale Zeit, die das Gerät benötigt, um automatisch den entsprechenden Energiesparmodus zu erreichen	20 Min

Description du produit

Vue d'ensemble

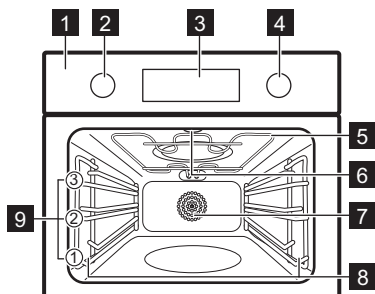

- 1 Bandeau de commande
- 2 Manette de sélection des modes de cuisson
- 3 Affichage
- 4 Manette de commande
- 5 Résistance
- 6 Éclairage
- 7 Chaleur tournante
- 8 Support de grille, amovible
- 9 Niveaux de la grille

Bandeau de commande

Allumer et éteindre l'appareil

Pour allumer l'appareil :

1. Appuyez sur les manettes. Les manettes sortent vers l'extérieur.
2. Tournez la manette de sélection des modes de cuisson pour sélectionner la fonction.
3. Tournez la manette de commande pour choisir les réglages.

Pour éteindre l'appareil : tournez la manette des modes de cuisson sur la position Arrêt 0.

Vue d'ensemble du bandeau de commande

	Appuyez pour régler les fonctions du minuteur.
	Maintenez la touche appuyée pour régler la fonction : Préchauffage rapide.
	Appuyez pour allumer et éteindre la lampe de l'appareil.
	Maintenez la touche appuyée pour régler la fonction : Touches Verrouil.
	Appuyez sur pour confirmer votre sélection.

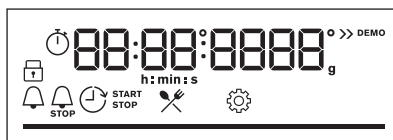









	L'appareil est verrouillé.
	Sous-menu : Cuisson assistée.
	Sous-menu : Configurations
	Préchauffage rapide est activée.
	Minuteur est activée.
	Heure de cuisson est activée.
	Démarrage retardé est activée.
	Compteur est activée.
	Barre de progression - indique visuellement quand l'appareil atteint la température réglée ou quand le temps de cuisson s'arrête.

Voyants de l'affichage

Affichage avec les principales fonctions :

Utilisation quotidienne

Modes de cuisson

	Chaleur tournante: Cuire des aliments de façon homogène, préserver leur tendreté, les sécher
	Chauffage Haut/Bas: Cuisson traditionnelle
	Plats Surgelés: Frites, pommes quartiers, rouleaux de printemps
	Fonction Pizza: Cuisson de pizza
	Cuisson de sole: Cuisson de gâteaux
	Décongélation: Décongélation
	Chaleur Tournante Humide: Cuisson
	Gril: Toaster, griller
	Turbo gril: Rôtir la viande, faire dorer

Pour certaines fonctions du four, l'éclairage peut s'éteindre automatiquement à une température inférieure à 80 °C.

Remarques sur : Chaleur Tournante Humide

Cette fonction était utilisée pour se conformer à la classe d'efficacité énergétique et aux exigences Ecodesign (selon les normes EU 65/2014 et EU 66/2014). Tests conformes aux normes : IEC/EN 60350-1.

La porte du four doit être fermée pendant la cuisson pour que la fonction ne soit pas interrompue et que le four fonctionne avec la plus grande efficacité énergétique possible.

Lorsque vous utilisez cette fonction, l'éclairage s'éteint automatiquement au bout de 30 secondes.

Cette fonction est conçue pour économiser de l'énergie en cours de cuisson. Lorsque vous utilisez cette fonction, la température à l'intérieur de la cavité peut différer de la température sélectionnée. La puissance peut être réduite.

Accès : Menu



Ouvrez le menu pour accéder à des plats à cuisson assistée et des configurations.

















1. Tournez la manette des modes de cuisson pour .





















L'affichage indique  .









2. Tournez la manette de commande et sélectionnez l'icône pour accéder au sous-menu. Appuyez sur la touche OK.

Sous-menu : Cuisson assistée

Légende	
	Réglage du poids disponible.
	Préchauffez l'appareil avant de commencer la cuisson.
	Niveau de grille. Reportez-vous à Description du produit.

P1	Rôti de bœuf, saignant  2
P2	Rôti de bœuf, à point  2
P3	Rôti de bœuf, bien cuit  2
P4	Steak, à point  2
P5	Rôti de bœuf/braisé   1
P6	Rôti de bœuf, CBT* saignant  2
P7	Rôti de bœuf, CBT* à point  2
P8	Rôti de bœuf, CBT* bien cuit  2
P9	Filet, saignant  2
P10	Filet, à point  2
P11	Filet, bien cuit  2
P12	Rôti de veau   1
P13	Rôti de porc (par ex. col ou épaule)  1
P14	Émincé de porc  2
P15	Filet de porc, frais  1

P16	Travers -  2
P17	Gigot d'agneau avec os  1
P18	Poulet, entier  1
P19	Poulet, moitié  2
P20	Blanc de poulet  2
P21	Cuisses de poulet, fraîches  2
P22	Canard entier  1
P23	Oie, magret  2
P24	Pain de viande  1
P25	Poisson, entier, grillé  2
P26	Filet de poisson  3
P27	Cheesecake  3
P28	Tourte aux pommes  2
P29	Tartelettes aux pommes  2
P30	Tarte aux pommes  2
P31	Brownies  2
P32	Muffins  2
P33	Quatre-quarts  1
P34	Pommes de terre au four  2
P35	Pomme quartiers  2
P36	Mélange de légumes grillés  2

P37	Croquettes, surgelées  2
P38	Frites  2
P39	Lasagnes avec feuilles de pâtes sèches  1
P40	Gratin de pommes de terre  1
P41	Pizza fraîche, pâte fine  1
P42	Pizza fraîche, croûte épaisse  1
P43	Quiche lorraine  1
P44	Baguette/Ciabatta/Pain blanc  2
P45	Céréales complètes/Riz/Pain noir  1

*CBT - Cuisson à basse température

Sous-menu : Configurations

	Réglage	Valeur
01	Heure actuelle	Modifier
02	Affichage Luminosité	1 - 5
03	Son touches	1 - Bip, 2 - Clic, 3 - Son désactivé
04	Volume alarme	1 - 4
05	Compteur	Marche / Arrêt
06	Eclairage four	Marche / Arrêt
07	Préchauffage rapide	Marche / Arrêt
08	Mode démo	-
09	Version du logiciel	Contrôle
10	Réinitialiser tous les réglages	Oui/Non

Dépannage

Si vous rencontrez un problème avec votre appareil, consultez le chapitre Dépannage

dans la version complète de la notice d'utilisation disponible sur : www.ikea.com.

Efficacité énergétique

Fiche d'informations produits et informations produits conformément aux réglementations de l'UE relatives à l'étiquetage énergétique et à l'écoconception

Nom du fournisseur	IKEA
Identification du modèle	FRILLESBO 506.140.73
Indice d'efficacité énergétique	80,8
Classe d'efficacité énergétique	A+
Consommation d'énergie avec charge standard, en mode conventionnel	0,99 kWh/cycle
Consommation d'énergie avec charge standard, en mode chaleur tournante	0,59 kWh/cycle
Nombre de cavités	1
Source de chaleur	Électricité
Volume	43 l
Type de four	Four encastrable
Masse	33,6 kg

Informations produits pour la consommation d'énergie et le temps maximum requis pour atteindre le mode faible puissance applicable

Consommation d'énergie en mode veille	0,8 W
Temps maximum requis pour que l'équipement atteigne automatiquement le mode basse puissance applicable	20 min

Descrizione del prodotto

Panoramica generale

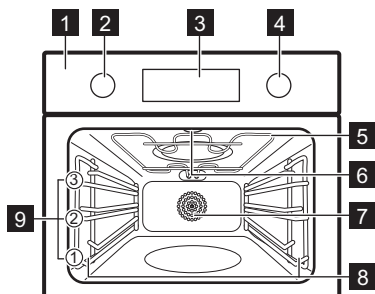

- 1 Pannello dei comandi
- 2 Manopola di regolazione delle funzioni cottura
- 3 Display
- 4 Manopola di regolazione
- 5 Resistenza
- 6 Lampadina
- 7 Ventola
- 8 Supporto ripiano, rimovibile
- 9 Posizioni ripiano

Pannello dei comandi

Accensione e spegnimento dell'apparecchiatura

Per accendere l'apparecchiatura:

1. Premere le manopole. Le manopole fuoriescono.
2. Ruotare la manopola delle funzioni cottura per selezionare una funzione.
3. Ruotare la manopola di controllo per regolare le impostazioni.

Per spegnere l'apparecchiatura: ruotare la manopola delle funzioni cottura fino a portarla in posizione off 0.

Panoramica del pannello di controllo

	Premere per impostare le funzioni del timer.
	Tenere premuto per impostare la funzione: Riscaldamento rapido.
	Premere per accendere e spegnere la luce dell'apparecchiatura.
	Tenere premuto per impostare la funzione: Blocco.
	Premere per confermare la selezione.

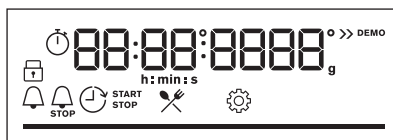

	L'apparecchiatura è bloccata.
	Sottomenu: Cottura guidata.
	Sottomenu: Impostazioni
	Riscaldamento rapido è attivato.
	Contaminuti è attivato.
	Tempo di cottura è attivato.
	Ora partenza ritardata è attivato.
	Timer è attivato.
	Barra di avanzamento: indica visivamente quando l'apparecchiatura raggiunge la temperatura impostata o quando il tempo di cottura termina.

Spie display

Display con le funzioni chiave:

Uso quotidiano

Funzioni cottura

	Cottura ventilata: Cottura omogenea, tenerezza, essiccazione
	Cottura convenzionale: Cottura tradizionale
	Cibi congelati: Patatine fritte, spicchi di patate, involtini primavera
	Funzione Pizza: Preparazione della pizza
	Resistenza inferiore: Preparazione di dolci da forno
	Scongelamento: Scongelamento
	Cottura ventilata umida: Cottura al forno
	Grill: Tostatura, cottura al grill
	Doppio grill ventilato: Arrostire carne, rosolare

La lampada si potrebbe spegnere automaticamente a temperature inferiori a 80°C durante alcune funzioni del forno.

Note su: Cottura ventilata umida

Questa funzione è stata utilizzata per la conformità alla classe energetica e ai requisiti di ecodesign (secondo la normativa EU 65/2014 e EU 66/2014). Test conformemente a: IEC/EN 60350-1.

La porta del forno dovrebbe essere chiusa in fase di cottura, in modo che la funzione non venga interrotta. Ciò garantisce inoltre che il forno funzioni con la più elevata efficienza energetica possibile.

Quando viene usata questa funzione, la lampada si spegne automaticamente dopo 30 secondi.

Questa funzione è progettata per il risparmio energetico durante la cottura. Quando si utilizza questa funzione, la temperatura all'interno della cavità potrebbe essere diversa rispetto alla temperatura impostata. La potenza riscaldante potrebbe essere ridotta.

Accesso: Menu

Aprire il Menu per accedere ai piatti con Cottura guidata e alle impostazioni.

1. Ruotare la manopola per le funzioni cottura su































Il display visualizza .

















2. Ruotare la manopola di controllo e selezionare l'icona per accedere al sottomenu. Premere OK.

Sottomenu: Cottura guidata

Legenda	
	Regolazione del peso disponibile.
	Preriscaldare l'apparecchiatura prima di iniziare la cottura.
	Livello del ripiano. Fare riferimento a Descrizione del prodotto.

P1	Roast beef, al sangue 2
P2	Roast beef, cottura media 2
P3	Roast beef, ben cotto 2
P4	Bistecca, cottura media 2
P5	Manzo arrosto/brasato 1
P6	Roast beef, LTC al sangue* 2
P7	Roast beef, LTC cottura media* 2
P8	Roast beef, LTC ben cotto* 2
P9	Filetto, LTC 2
P10	Filetto, LTC 2
P11	Filetto, LTC 2
P12	Arrosto di vitello 1
P13	Maiale arrosto (per es. coppa o spalla) 1
P14	Maiale sfilacciato 2
P15	Lombo di maiale, fresco 1

P16	Costolette di maiale  2
P17	Cosciotto d'agnello con ossa  1
P18	Pollo, intero  1
P19	Pollo, mezzo   2
P20	Petto di pollo  2
P21	Cosce di pollo, fresche  2
P22	Anatra, intera   1
P23	Oca, petto  2
P24	Polpettone  1
P25	Pesce, intero, grigliato  2
P26	Filetto di pesce   3
P27	Cheesecake  3
P28	Torta di mele, ricoperta   2
P29	Crostata di mele  2
P30	Crostata di mele   2
P31	Brownie   2
P32	Muffin   2
P33	Torta in cassetta  1
P34	Patate al forno   2
P35	Patate a spicchi   2
P36	Verdure miste grigliate  2

P37	Crocchette, surgelate   2
P38	Patatine fritte   2
P39	Lasagna con strati di pasta secca   1
P40	Patate gratinate  1
P41	Pizza fresca, crosta sottile   1
P42	Pizza fresca, crosta spessa   1
P43	Quiche lorraine   1
P44	Baguette / ciabatta / pane bianco   2
P45	Pane integrale / segale / nero   1

*LTC - Cottura a bassa temperatura

Sottomenu: Impostazioni

	Impostazione	Valore
01	Imposta ora	Modifica
02	Luminosità	1 - 5
03	Volume toni	1 - Bip, 2 - Clic, 3 - Suono disattivato
04	Volume acustico	1 - 4
05	Timer	On/Off
06	Luce cappa	On/Off
07	Riscaldamento rapido	On/Off
08	Modalità demo	-
09	Versione software	Controllare
10	Ripristino impostazioni iniziali di fabbrica	Si / No

Risoluzione dei problemi

In caso di problemi con l'apparecchiatura consultare Risoluzione dei problemi nella

versione completa del Manuale d'uso disponibile su: www.ikea.com.

Efficienza energetica

Scheda informativa del prodotto e Informazioni sul prodotto in conformità alla normativa sull'etichettatura energetica dell'Unione Europea ed Ecodesign

Nome del fornitore	IKEA
Identificazione modello	FRILLESBO 506.140.73
Indice di efficienza energetica	80.8
Classe di efficienza energetica	A+
Consumo energetico con carico standard, modalità tradizionale	0.99 kWh/ciclo
Consumo di energia con un carico standard, modalità a circolazione d'aria forzata	0.59 kWh/ciclo
Numero di cavità	1
Fonte di calore	Elettricità
Volume	43 l
Tipo di forno	Forno da incasso
Massa	33.6 kg

Informazioni sul prodotto per il consumo energetico e il tempo massimo per raggiungere la modalità bassa potenza applicabile

Potenza elettrica assorbita in standby	0.8 W
Tempo massimo necessario al dispositivo per raggiungere automaticamente la modalità a bassa potenza applicabile	20 min



701138127-A-392025

