

GULLABERG

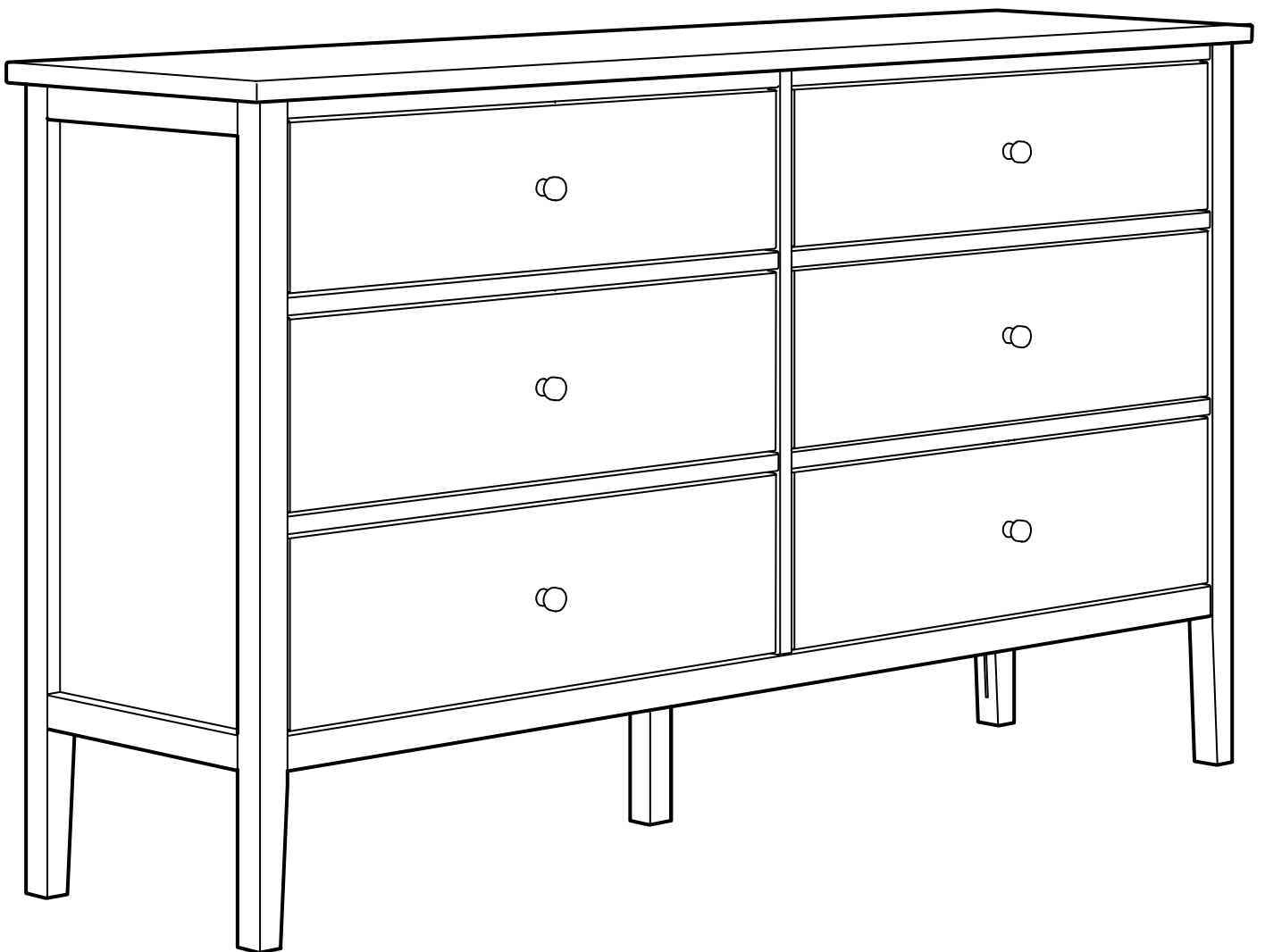

Design and Quality
IKEA of Sweden

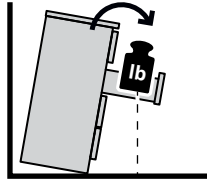
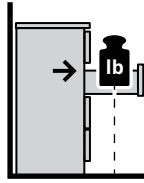
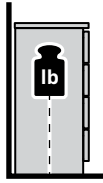

English

WARNING!

Children have died from furniture tipover.

To reduce the risk of furniture tipover:

- ALWAYS install anti-tip device provided.
- NEVER put a TV on this product.
- NEVER allow children to stand, climb, or hang on any drawers, doors, or shelves.
- NEVER open more than one drawer at a time.
- DO NOT defeat or remove the drawer interlock system; it is an important stability and safety system.
- Place heaviest items in the lowest drawers.
- Read and follow each step of the instruction carefully.

Français

AVERTISSEMENT !

Des enfants sont morts suite au basculement d'un meuble.

Afin de limiter le risque de basculement d'un meuble :

- TOUJOURS utiliser le système anti-basculement fourni.
- NE JAMAIS installer de TV sur ce produit.
- NE JAMAIS laisser d'enfants se tenir debout sur quelque tiroir, porte ou étagère que ce soit, y grimper ou s'y suspendre.
- NE JAMAIS ouvrir plus d'un tiroir à la fois.
- NE PAS mettre hors d'état de fonctionnement ou ne pas retirer le système de blocage individuel des tiroirs ; il constitue un important élément de stabilité et de sécurité.
- Placer les choses les plus lourdes dans les tiroirs du bas.
- Lire et suivre attentivement toutes les étapes de la notice de montage.

Español

ADVERTENCIA:

Han muerto niños por el vuelco de muebles

Para limitar el riesgo de vuelco de los muebles:

- Instala SIEMPRE el dispositivo antivuelco que se suministra.
- No pongas NUNCA un televisor encima de este producto.
- No permitas NUNCA que los niños se pongan de pie, trepen o se cuelguen de los cajones, puertas o baldas.
- No abras NUNCA más de un cajón a la vez.
- NO desconectes ni quites el sistema de bloqueo de los cajones ; se trata de un sistema importante de seguridad y estabilidad.
- Mete los objetos más pesados en los cajones inferiores.
- Lee y sigue cada paso de las instrucciones cuidadosamente.

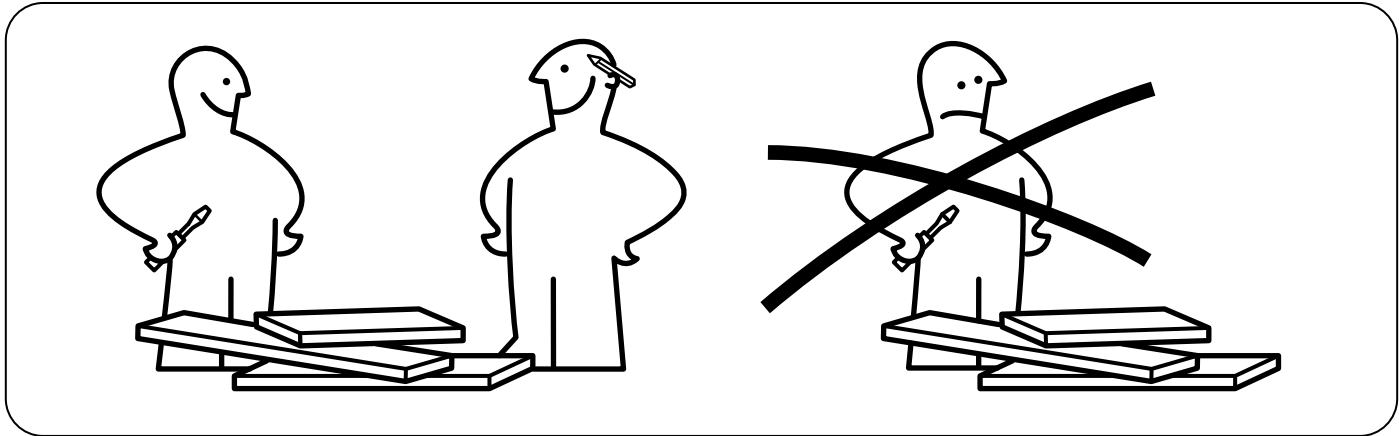
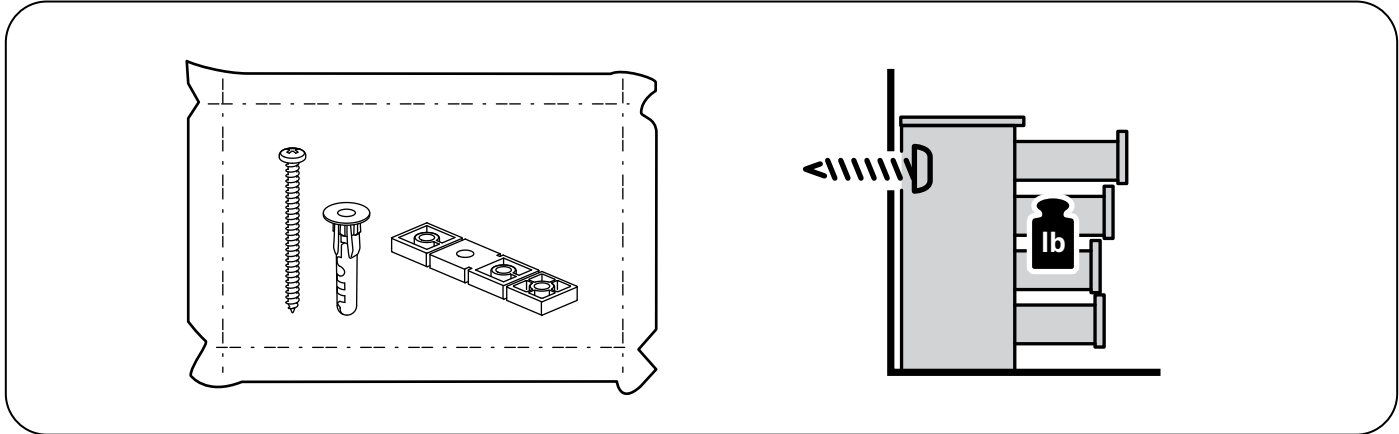
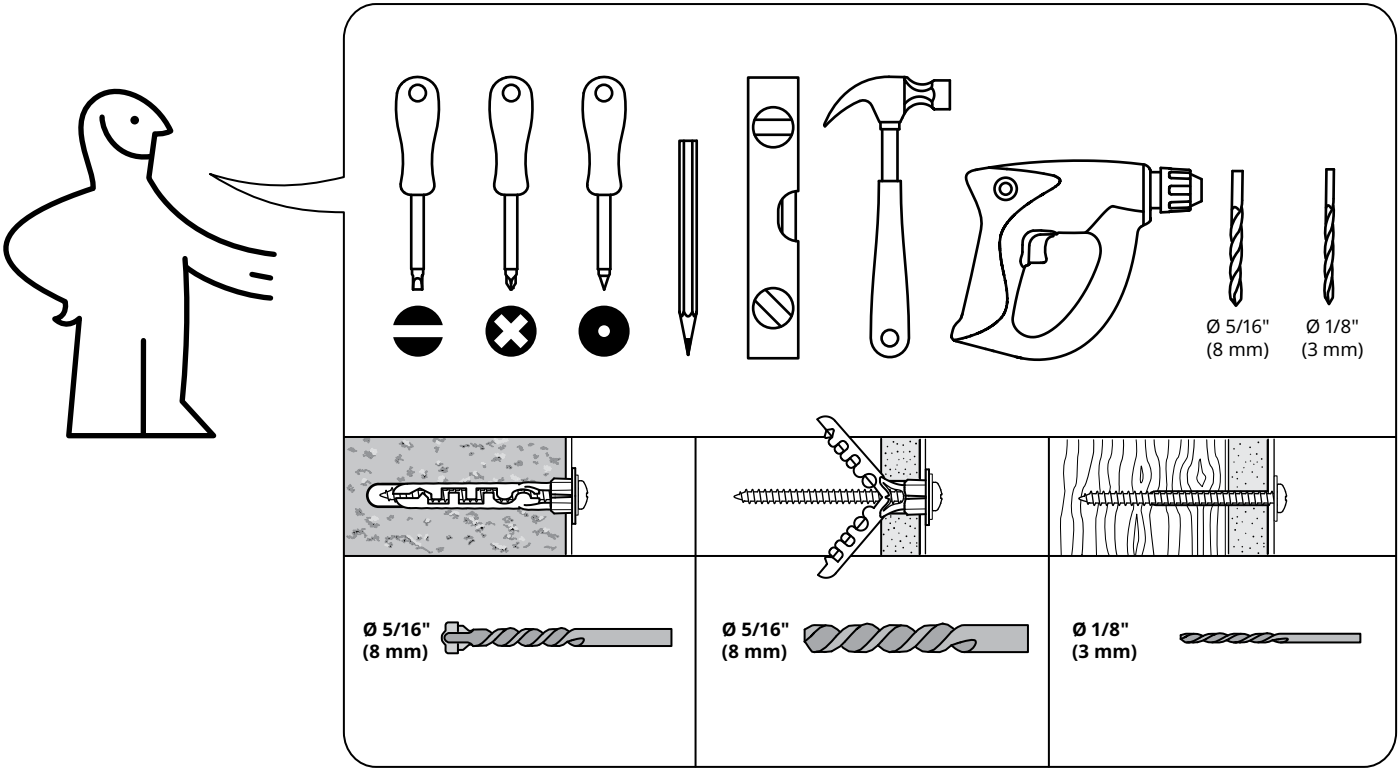

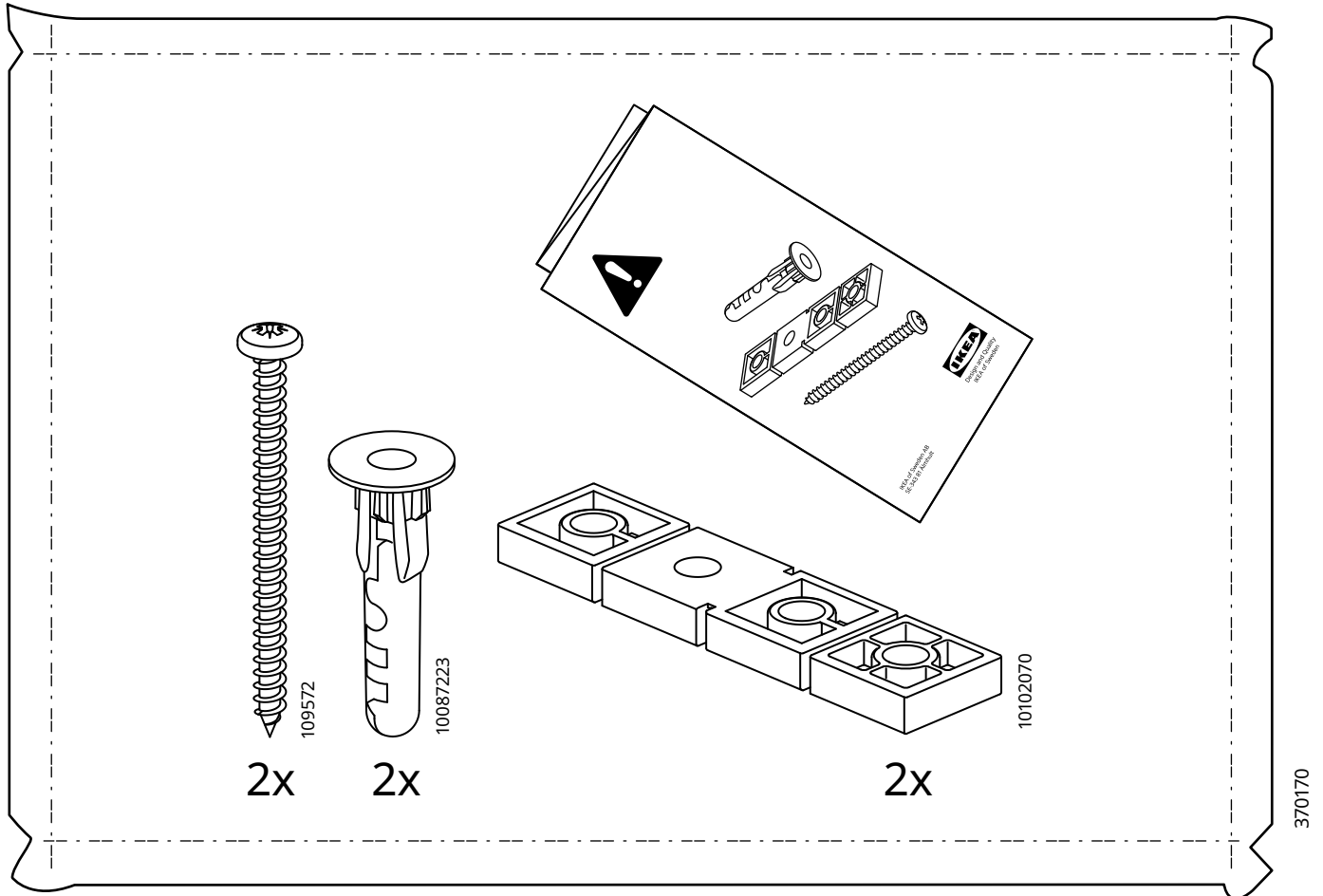
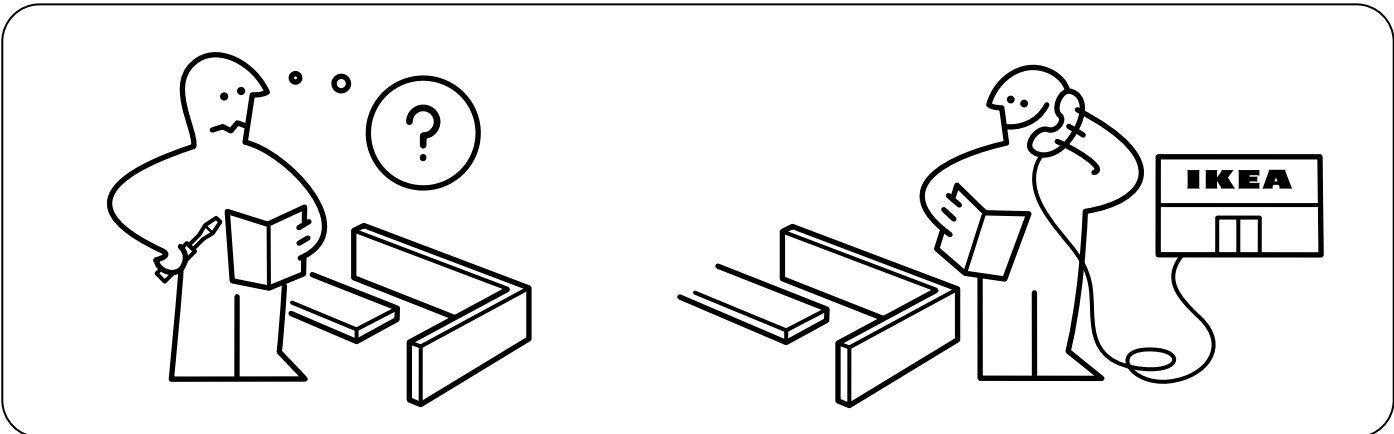
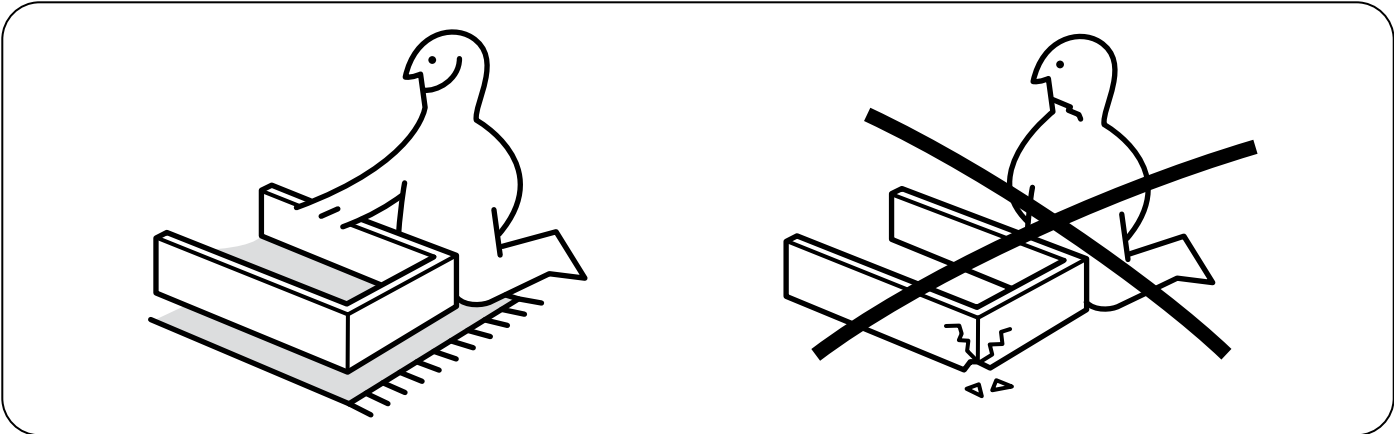

370170

1

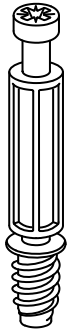

118331

22x

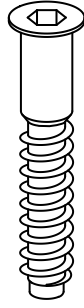

131359

4x

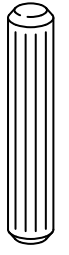

101345

26x

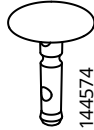

144574

8x



144575

8x

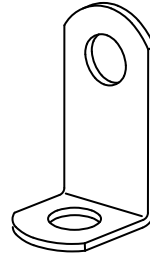

102553

4x

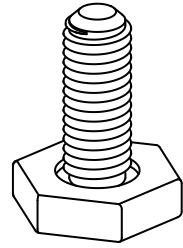

194970

5x



119250

4x



192800

18x

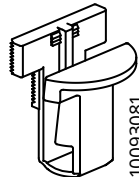

10093081

8x



10093082

8x



146114

36x

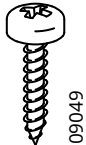

109049

2x

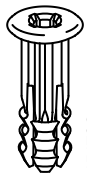

151708

6x

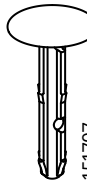

151707

6x

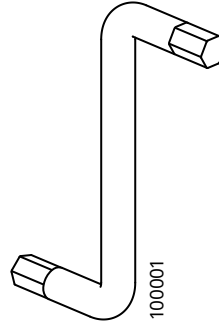

100001

1x

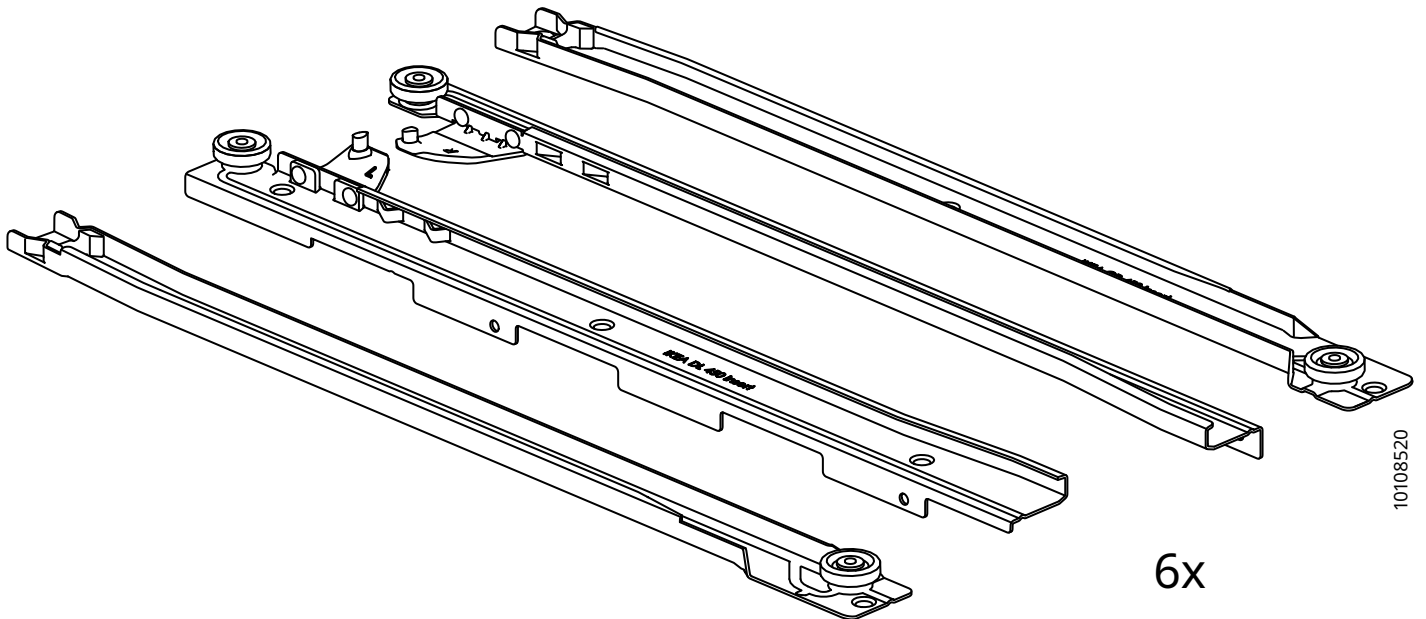

6x

10108520

2

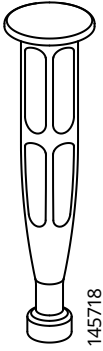

145718

24x

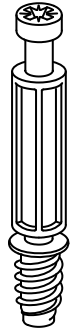

118331

24x

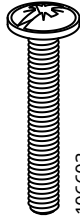

106603

6x



101345

24x

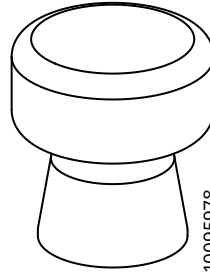

10095978
10096248
10118153

6x

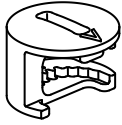

131361

48x



146114

36x

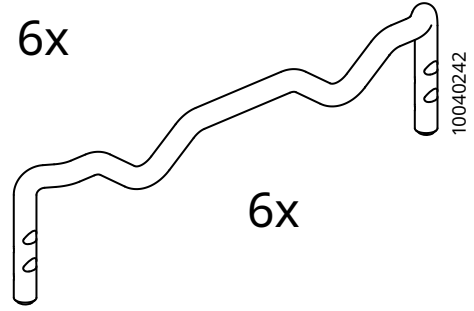

10040242

6x

1

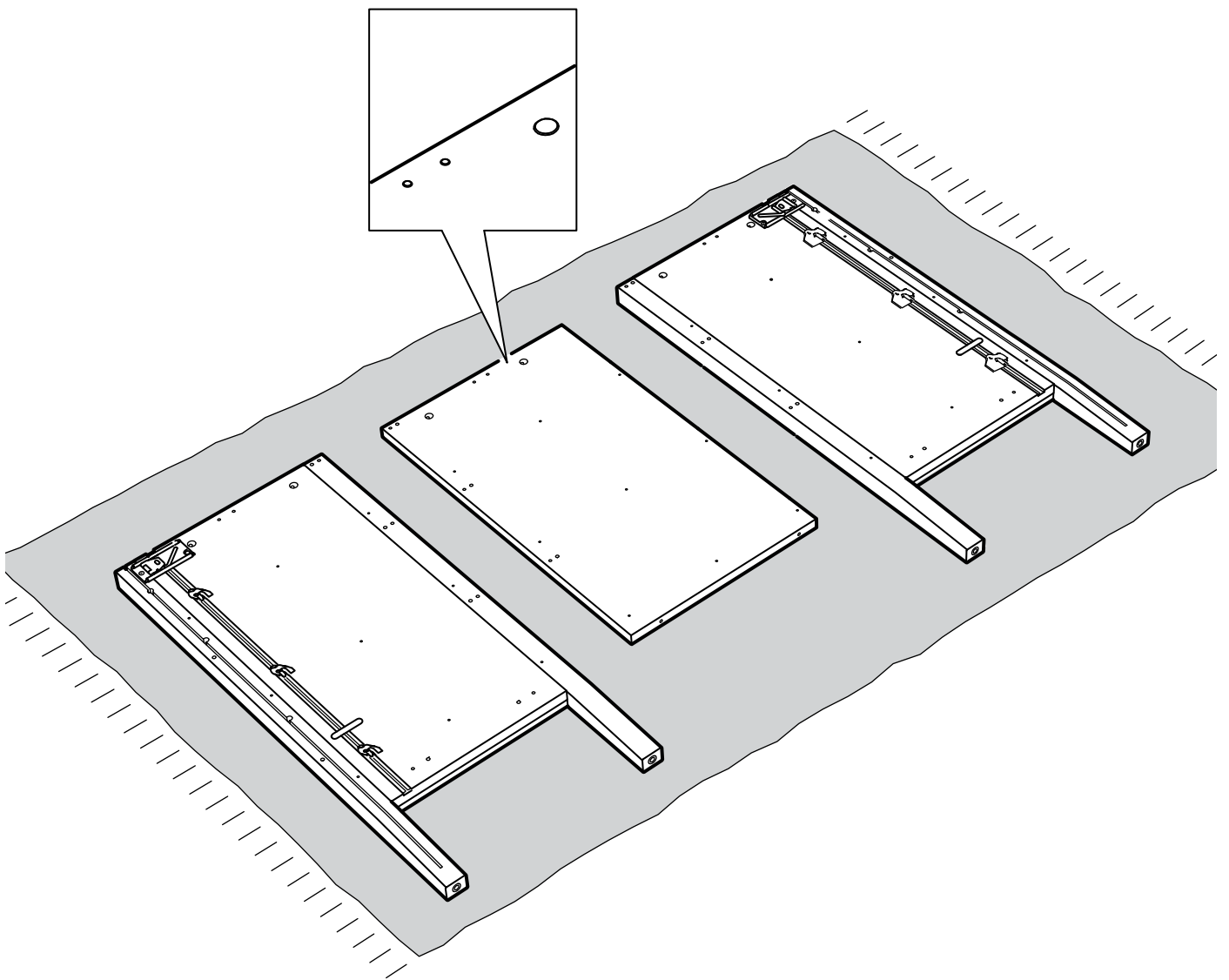

2

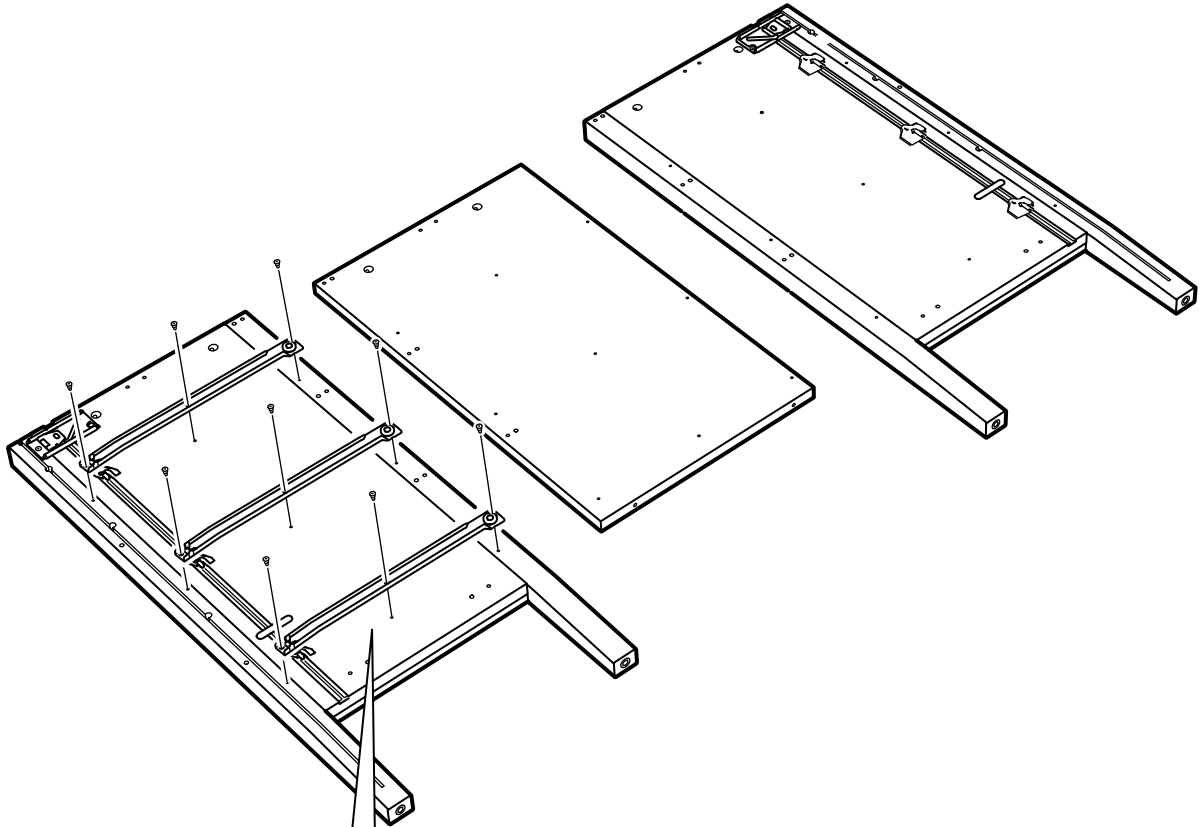

3x

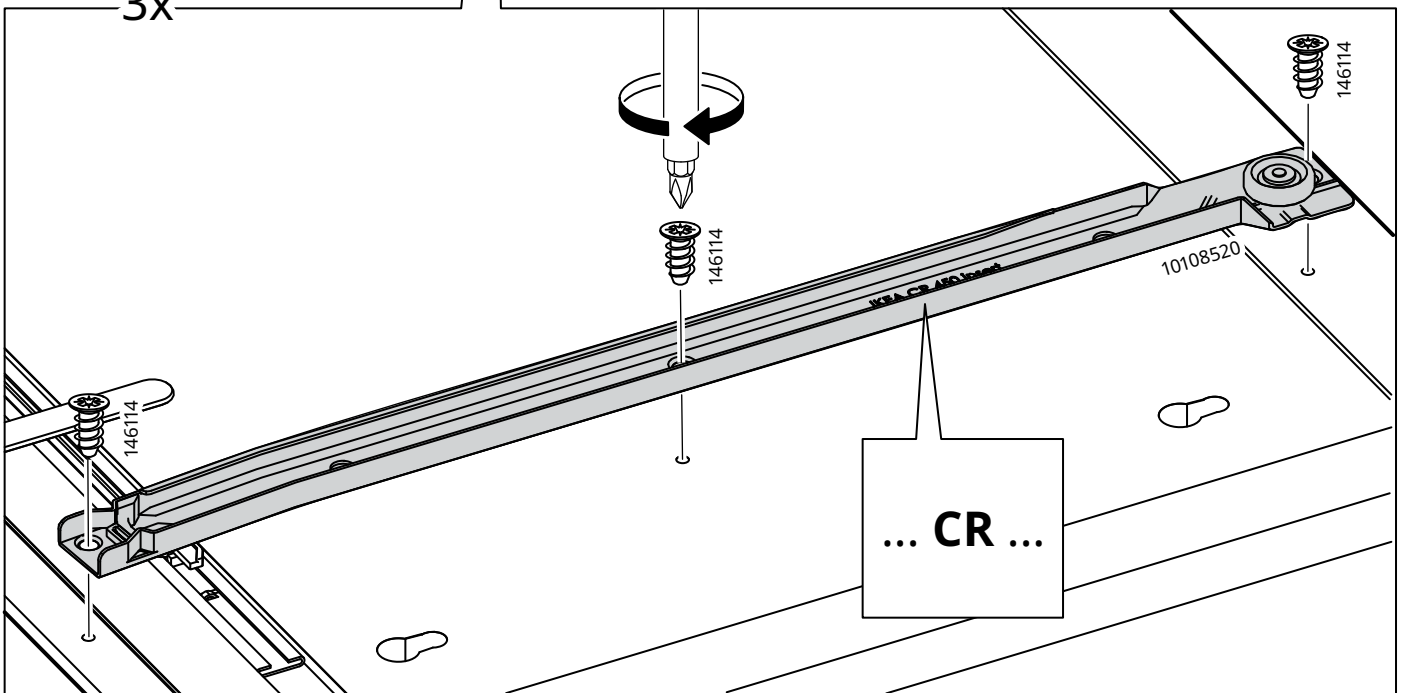

3

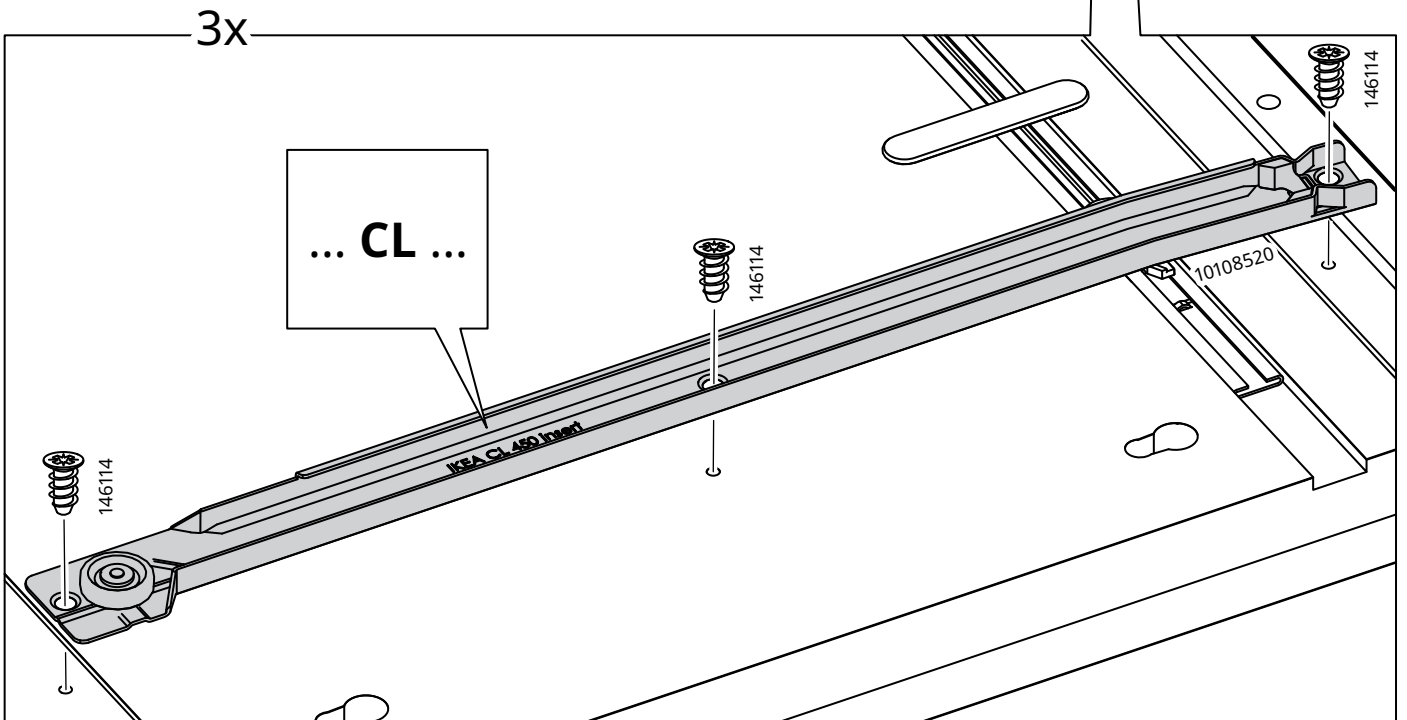
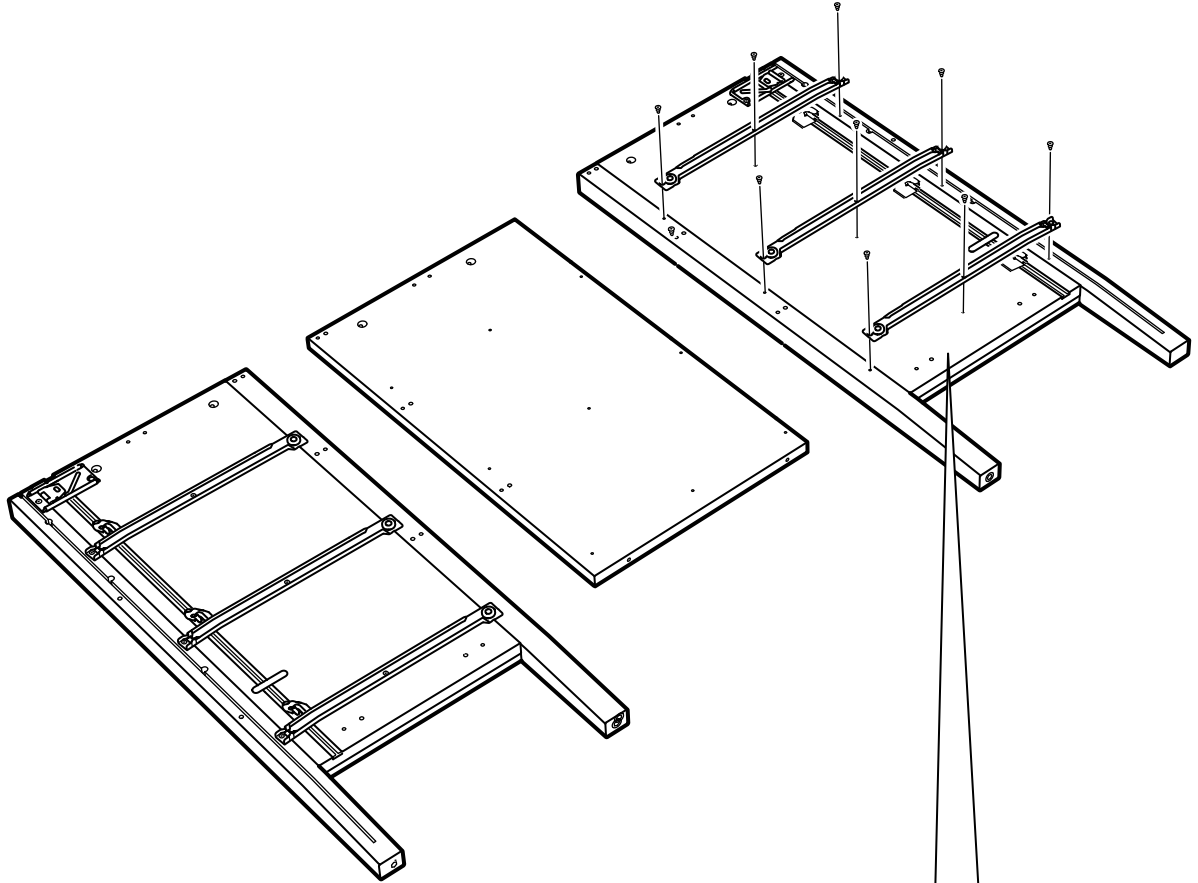

4

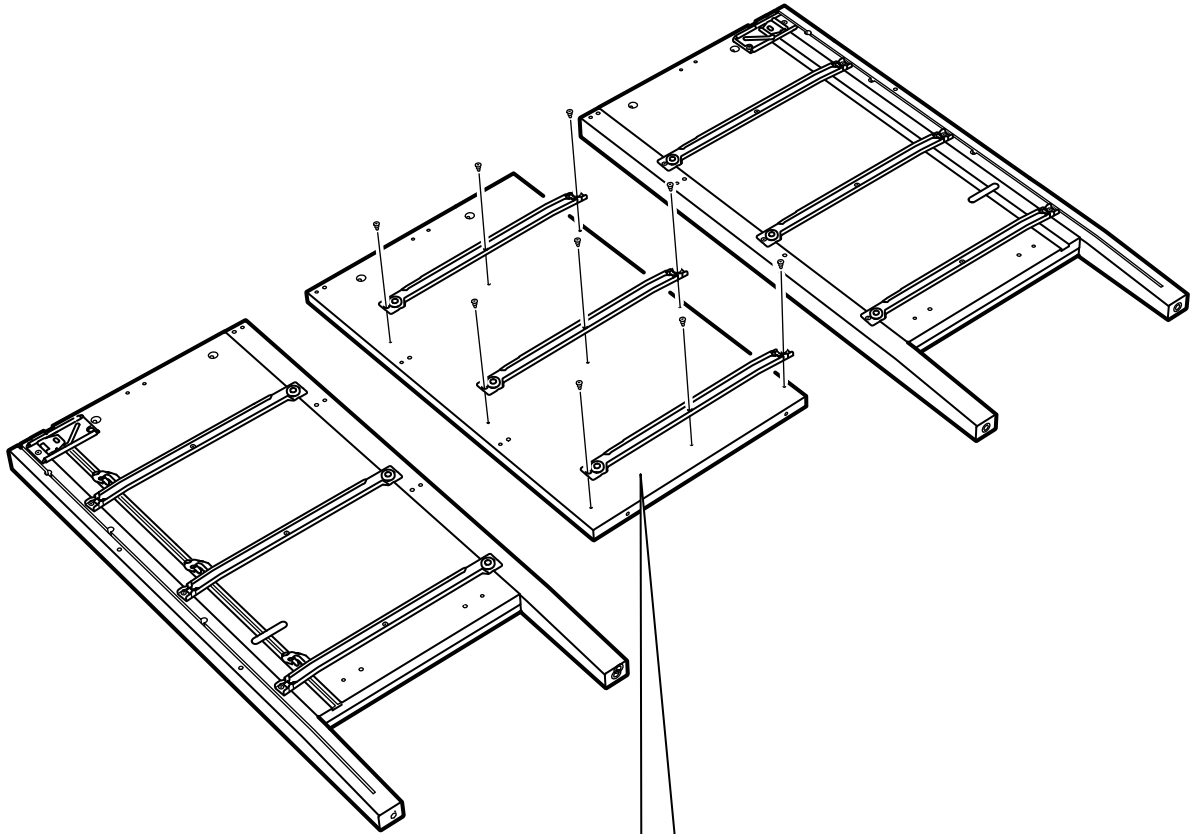

3x

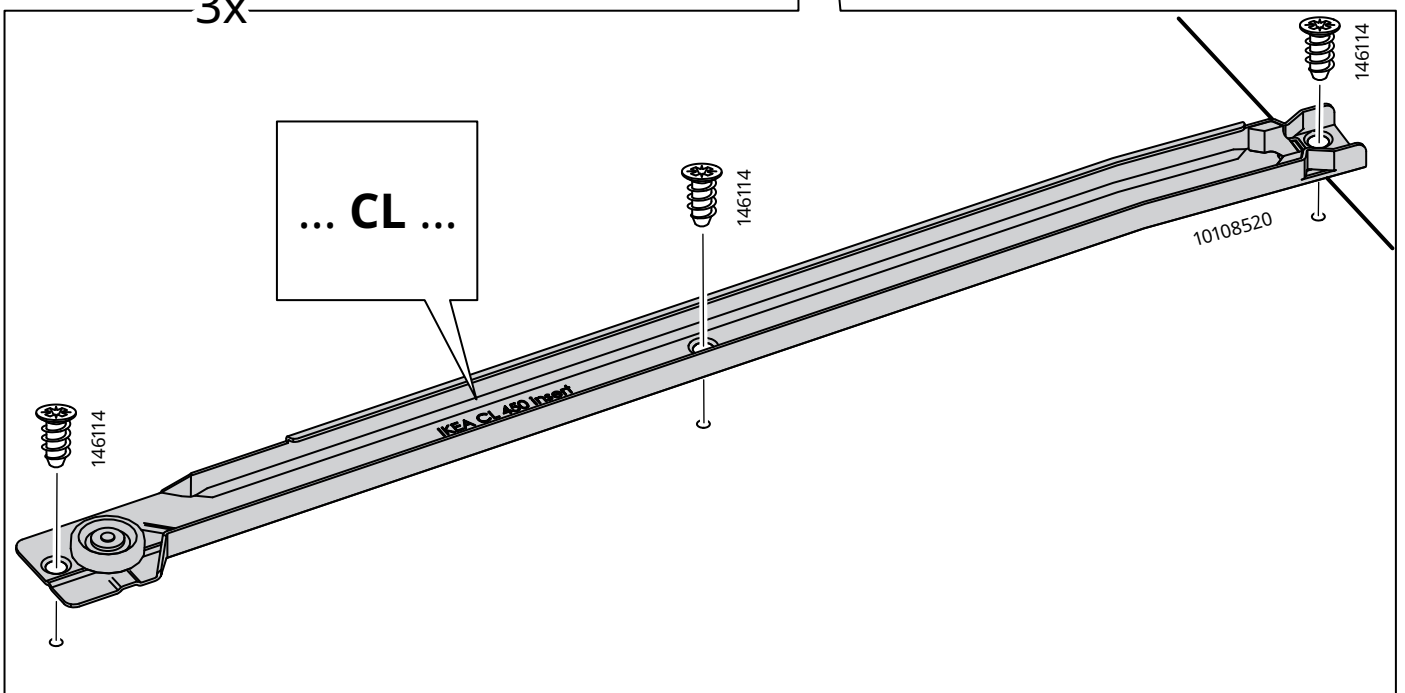

5

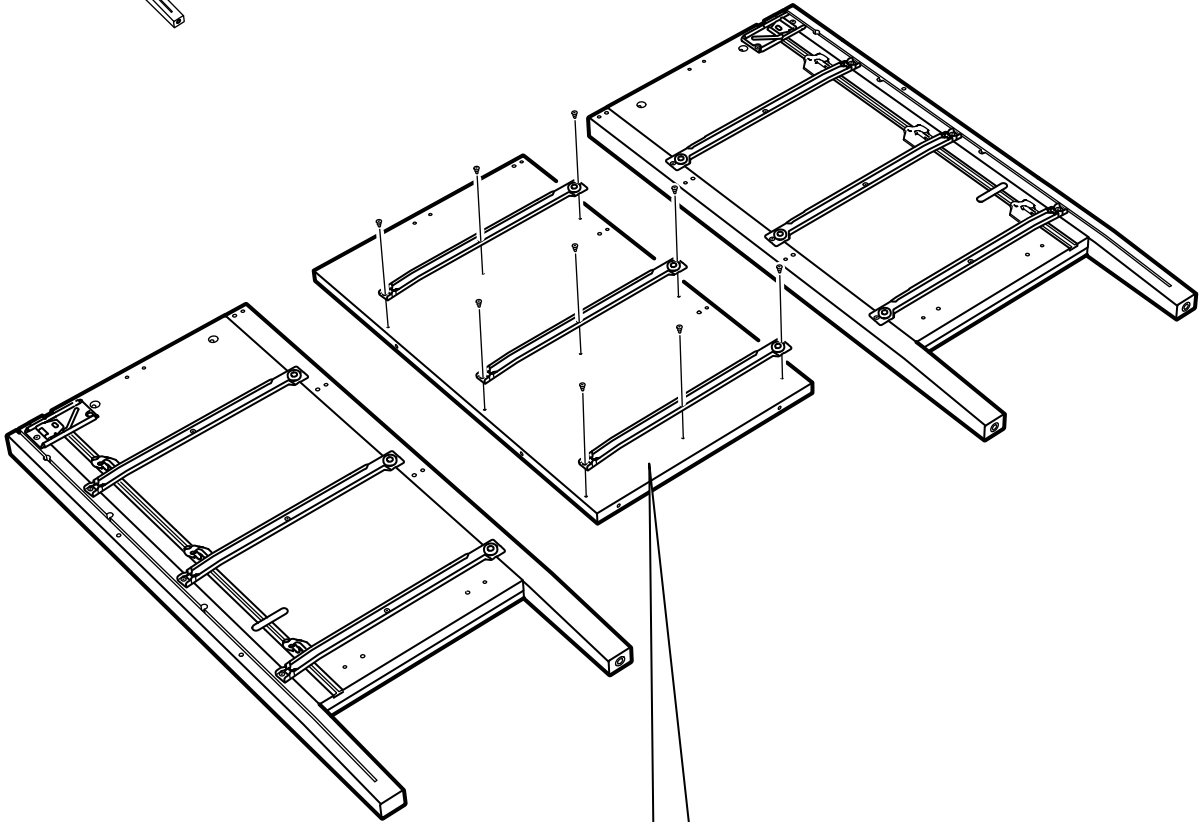
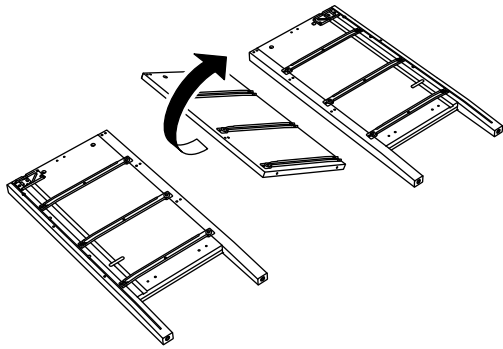

3x

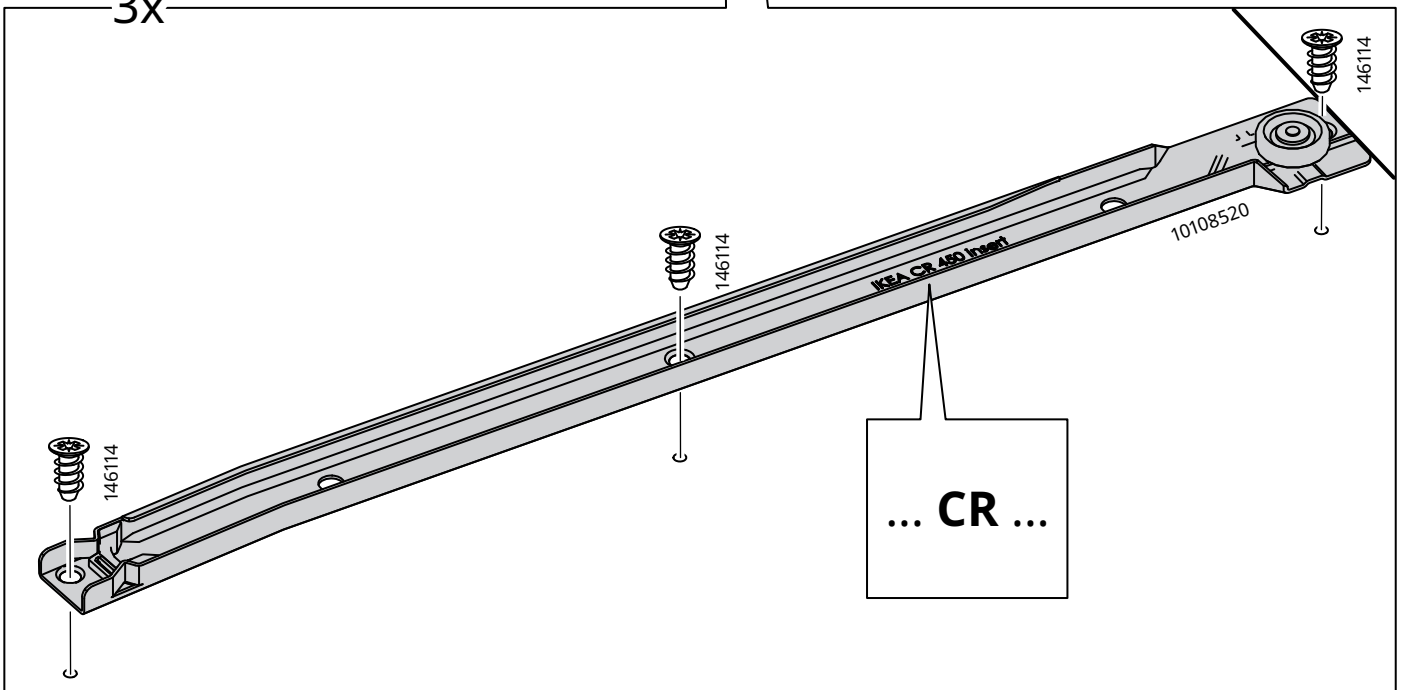

6

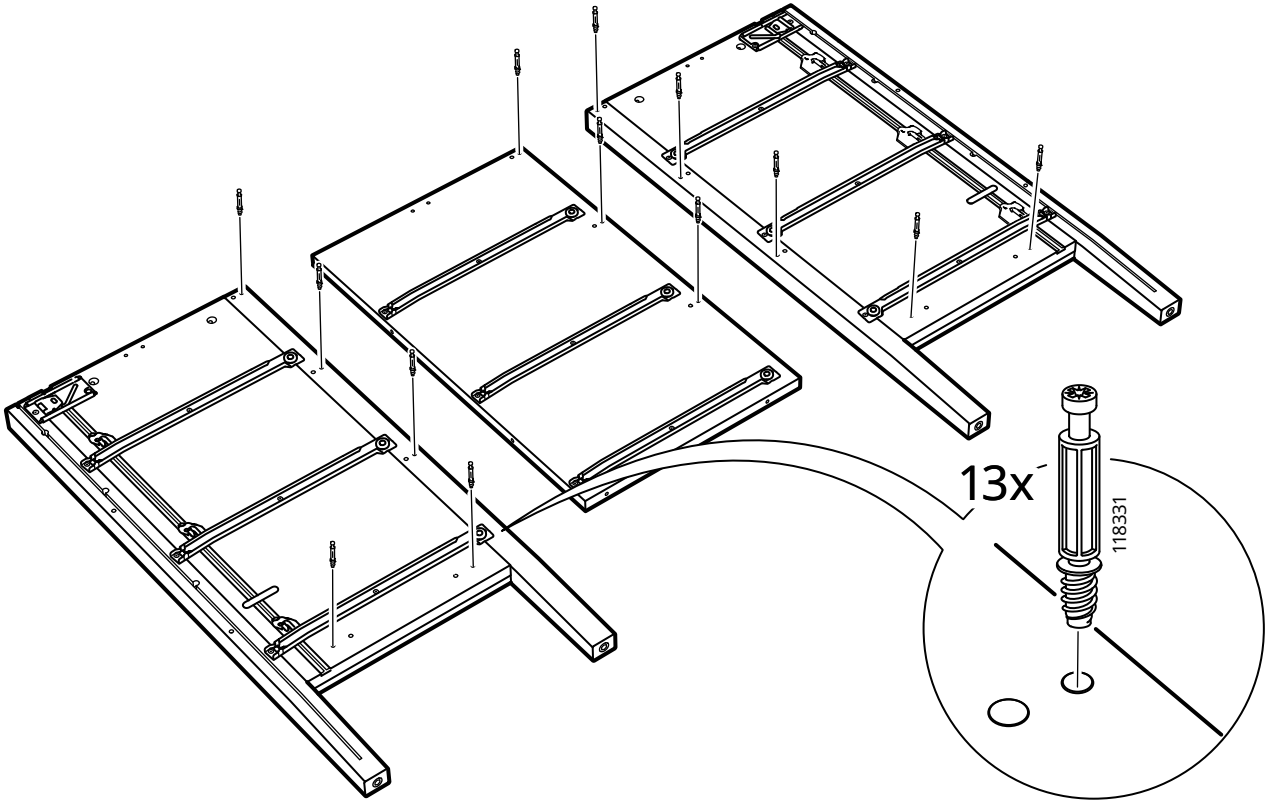

7

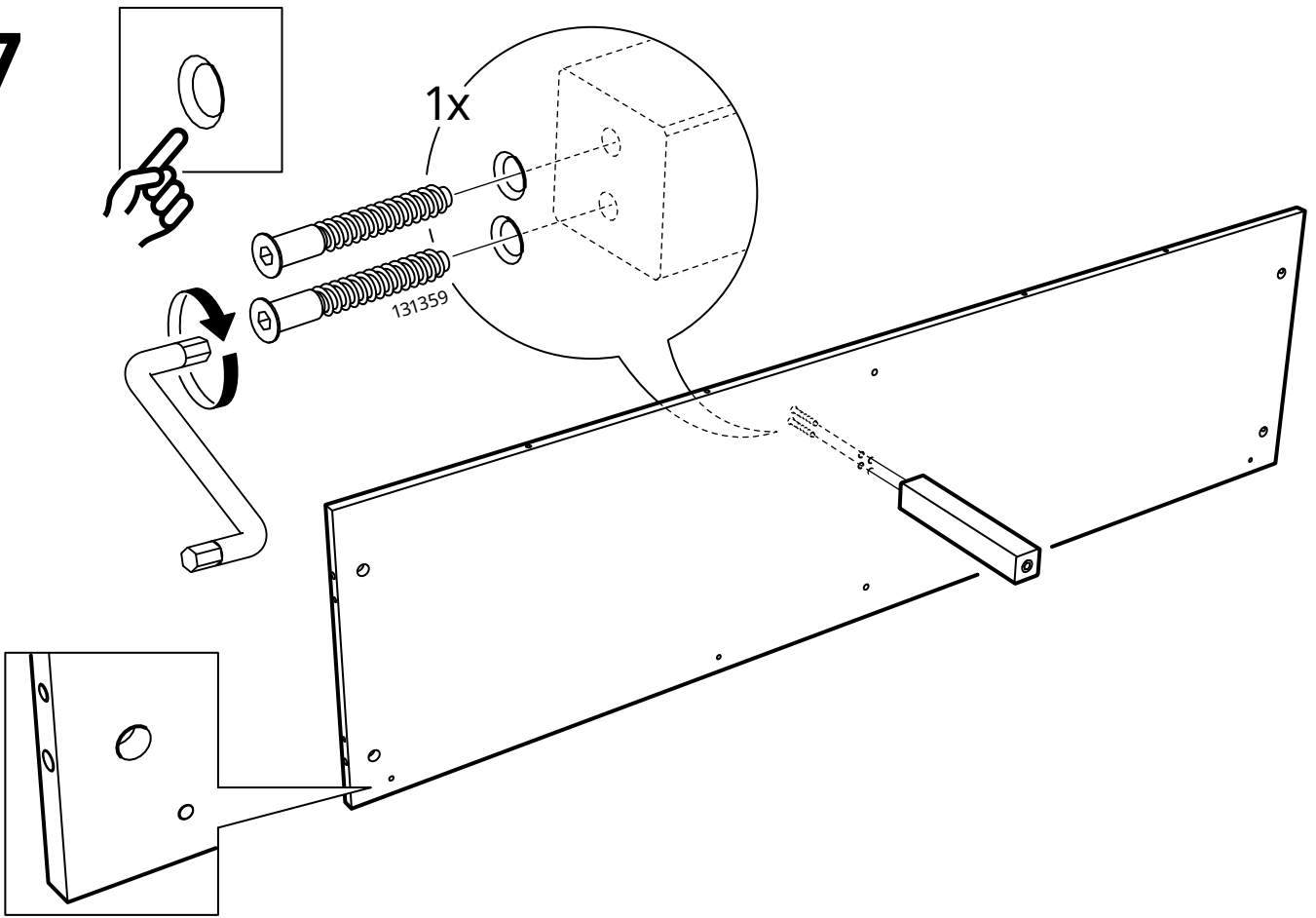

8

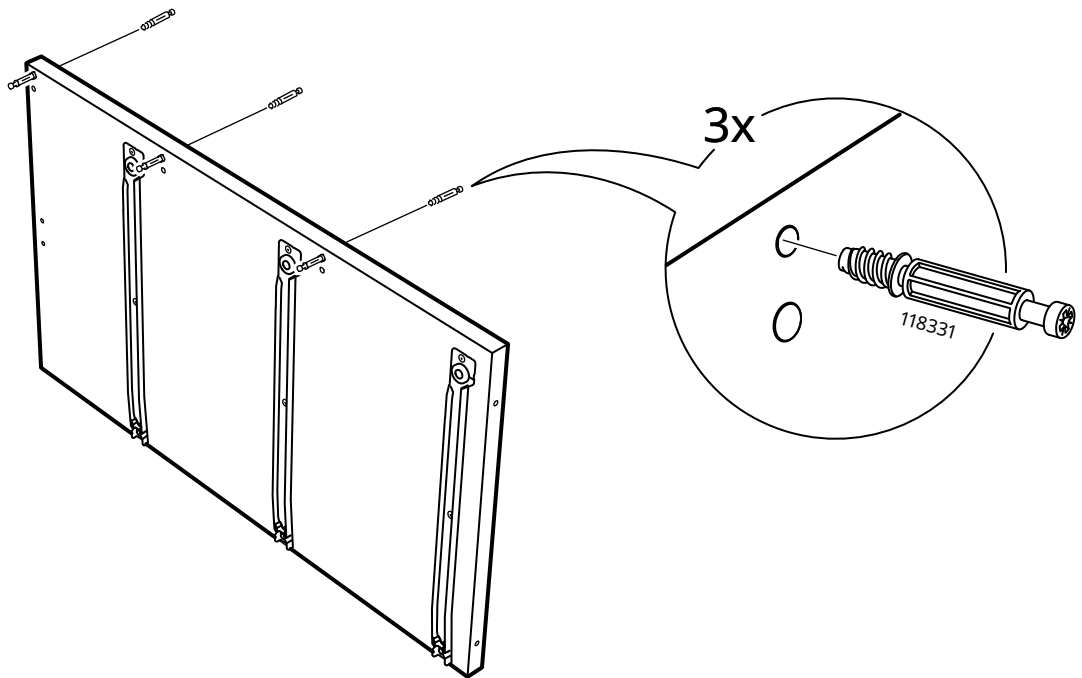

9

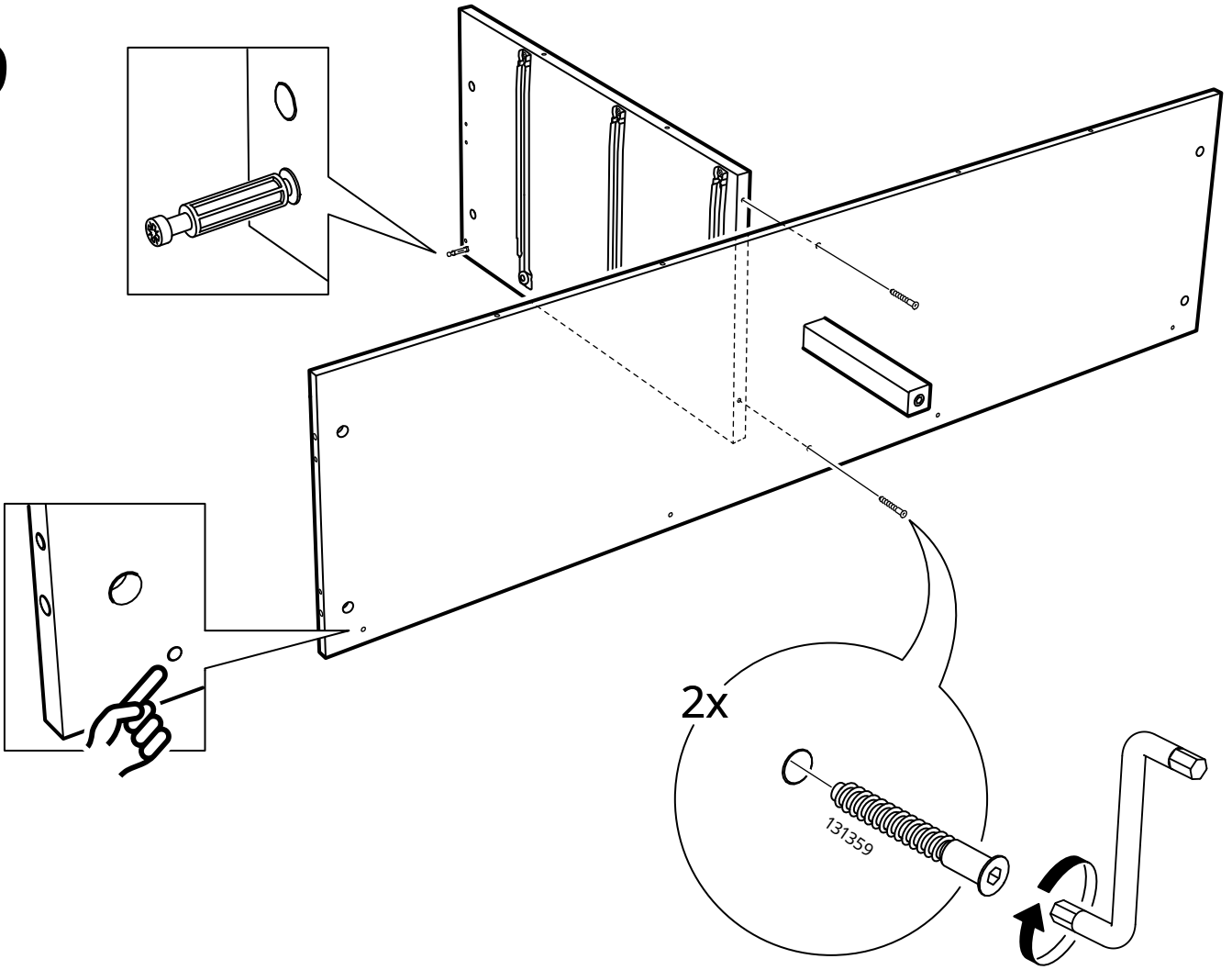

10

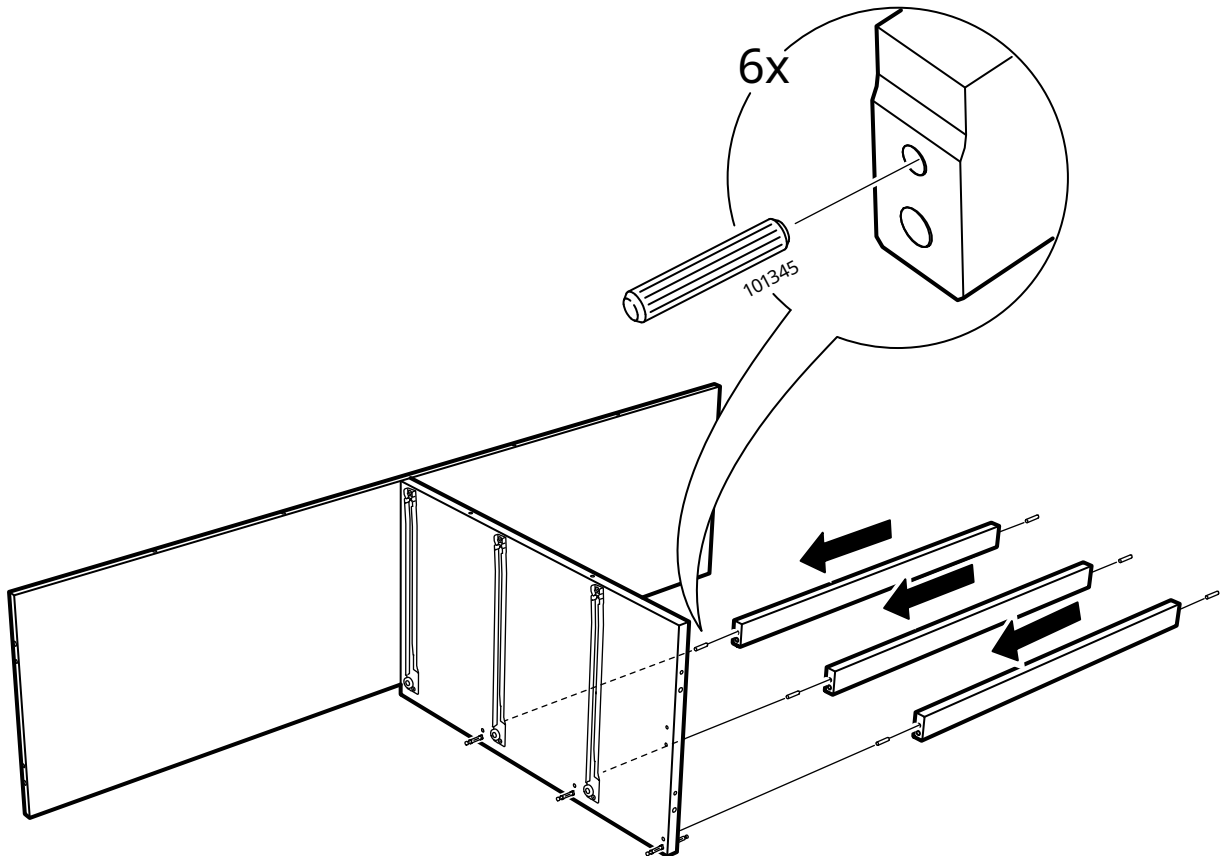

11

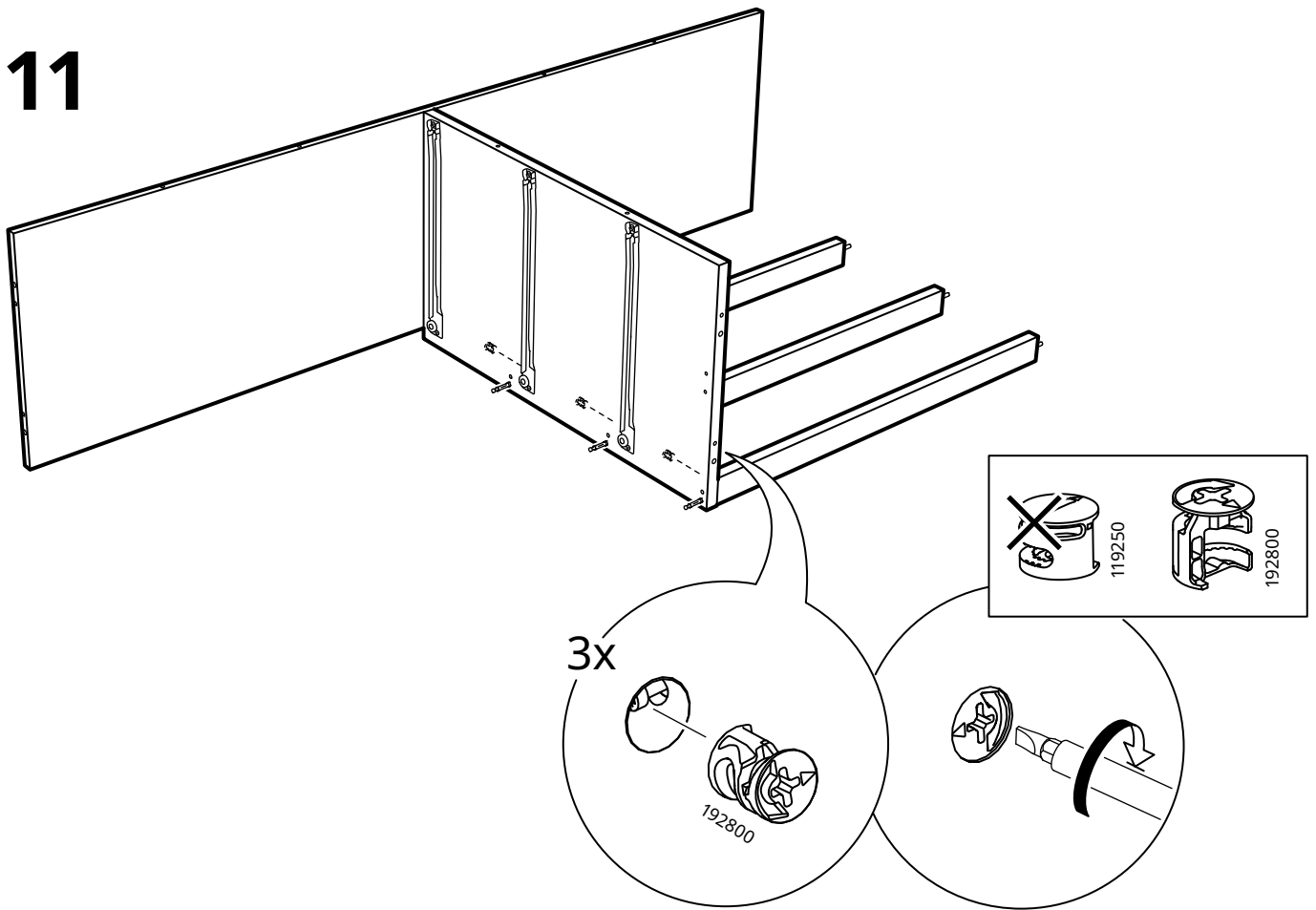

12

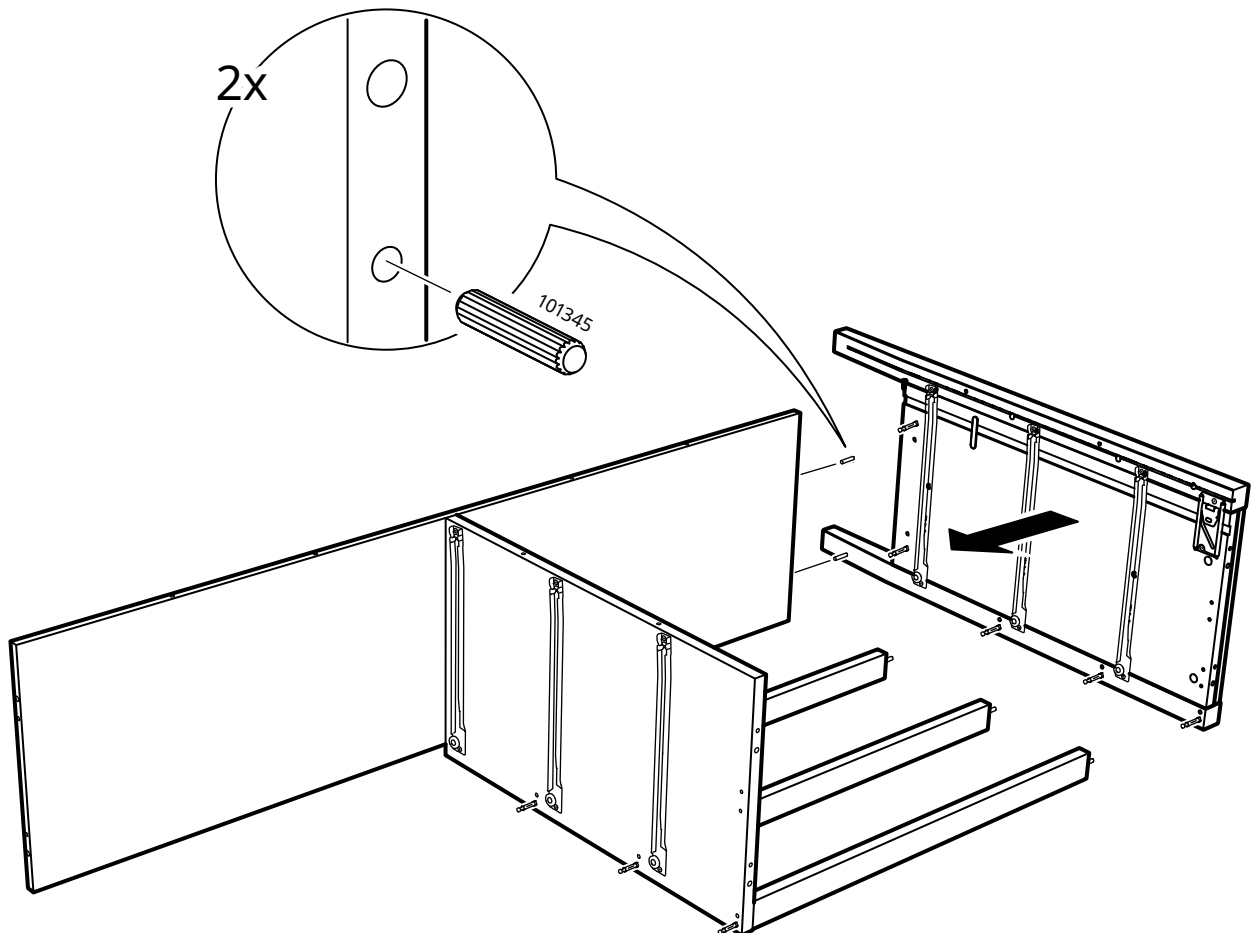

13

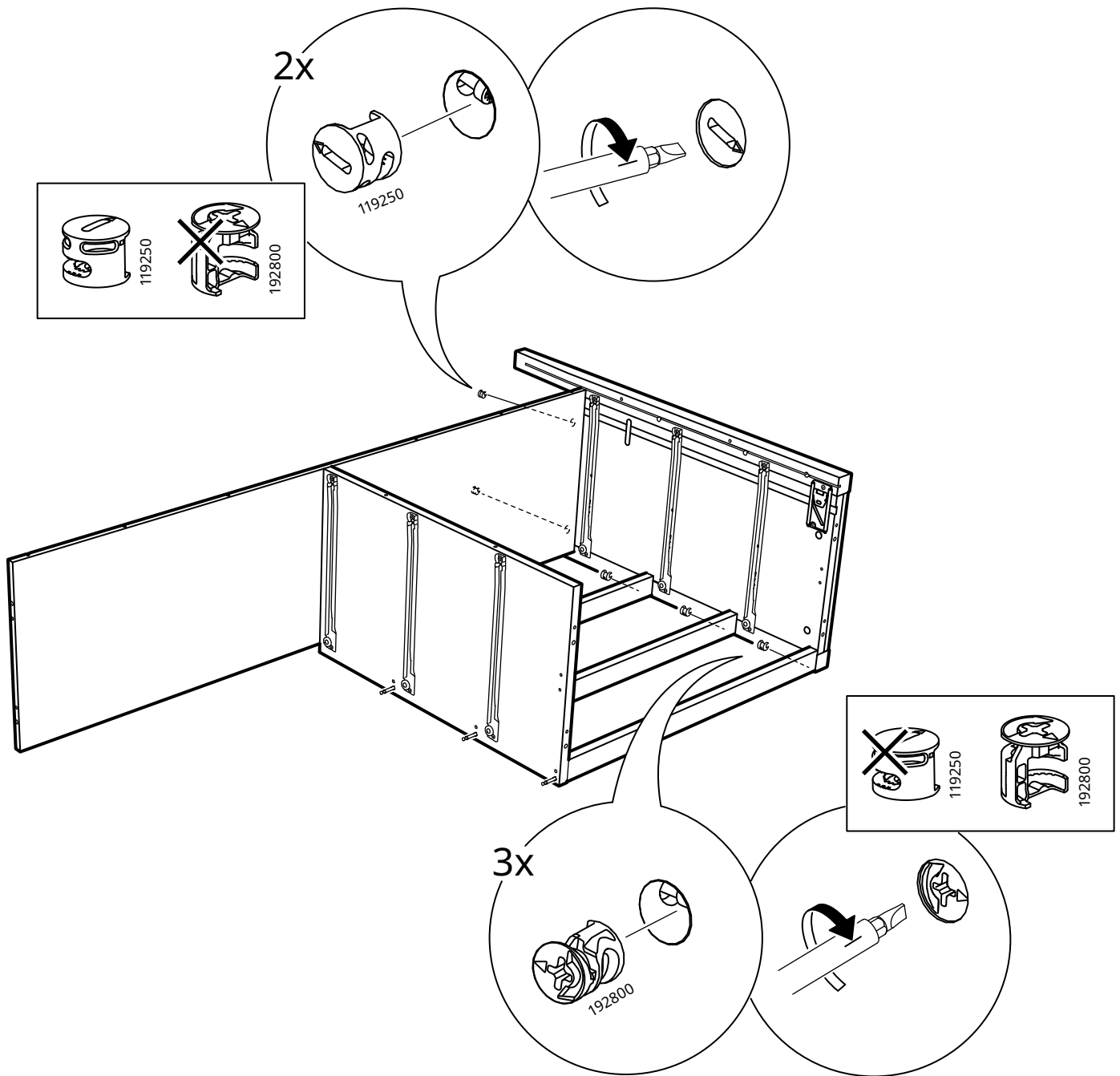

14

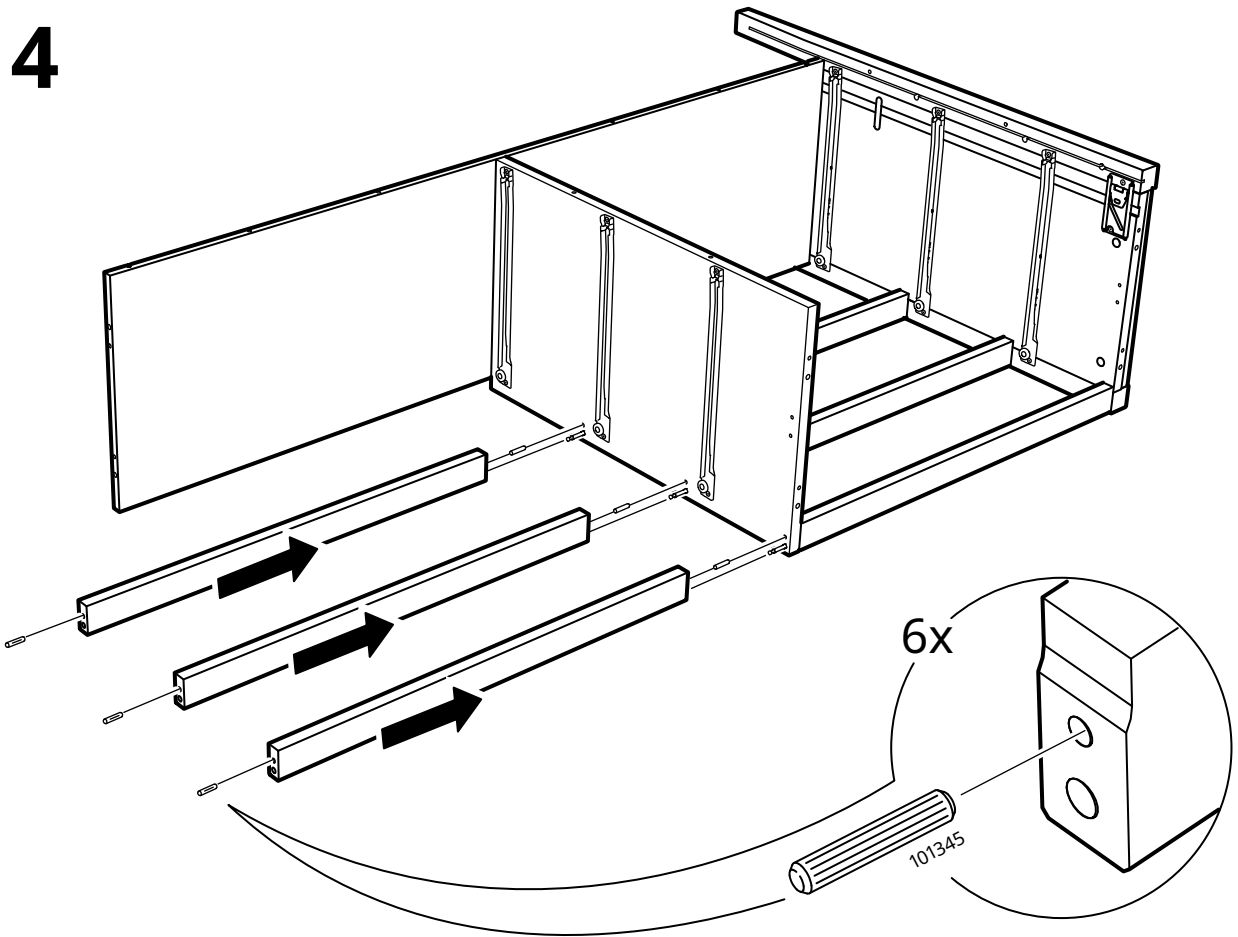

15

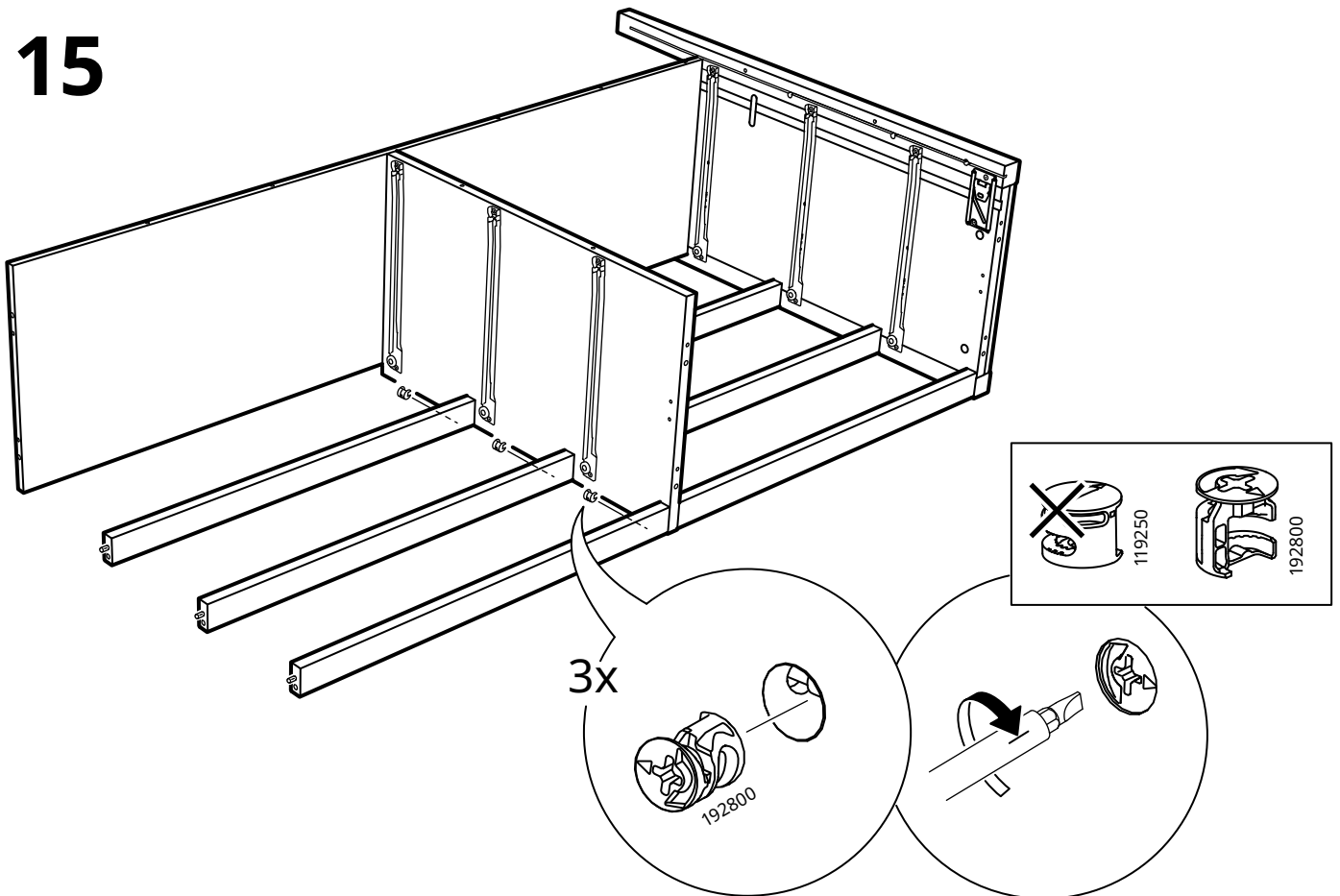

16

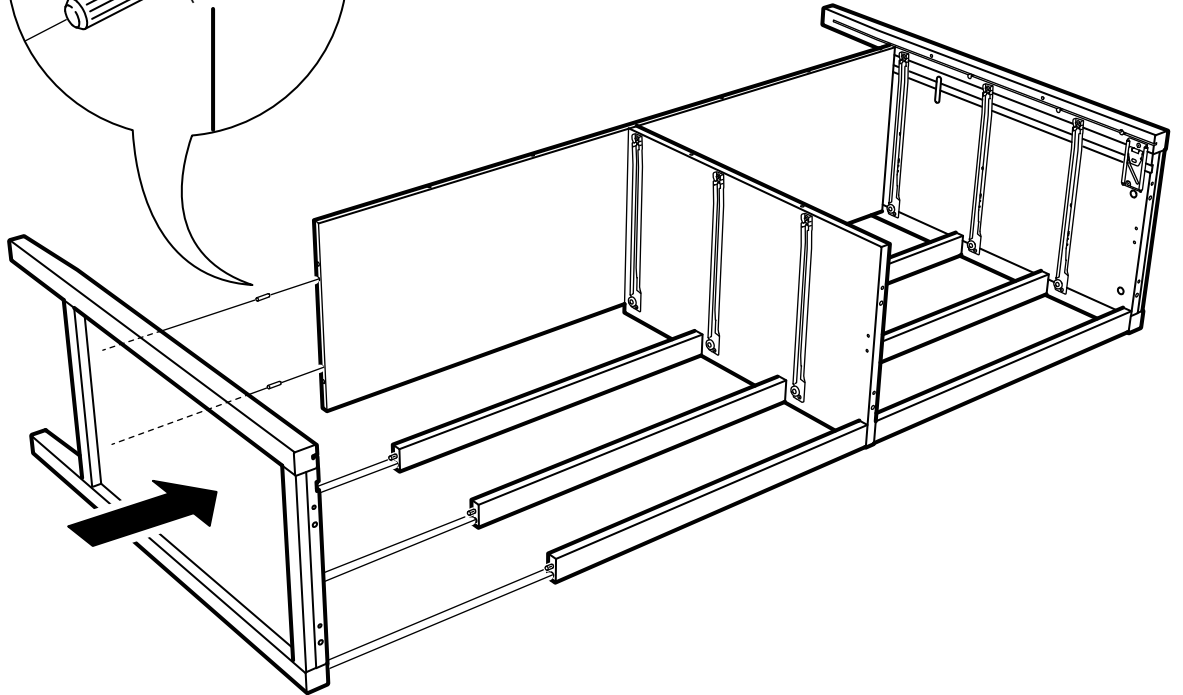
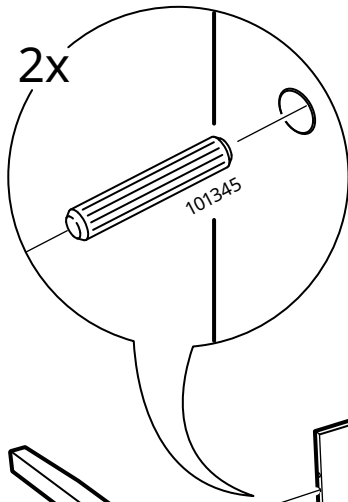

17

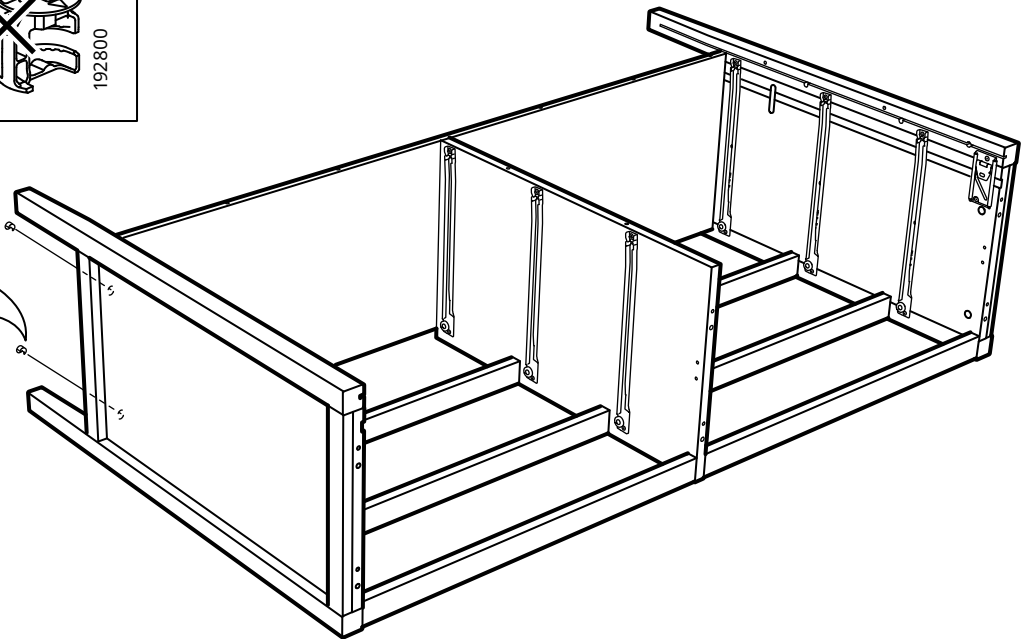
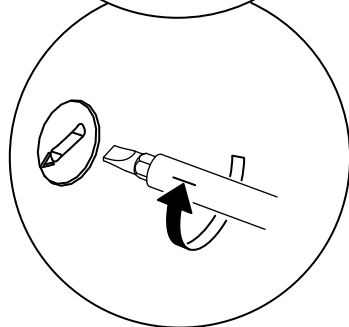
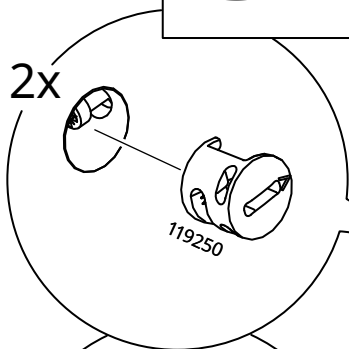
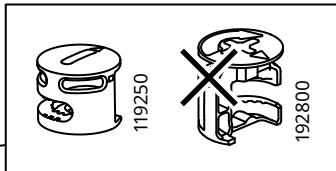

18

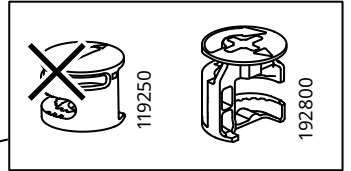
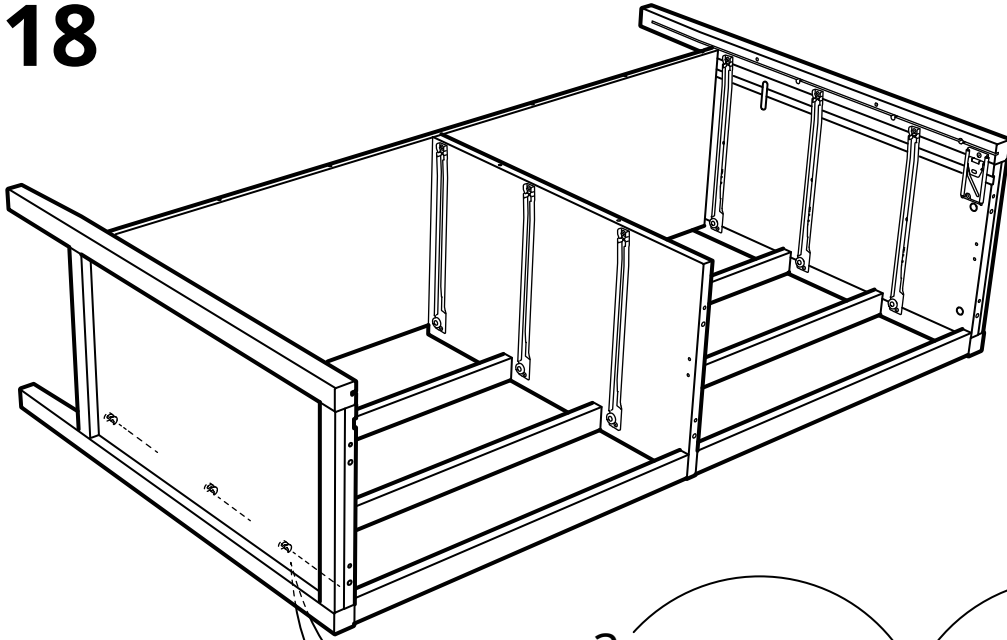

3x

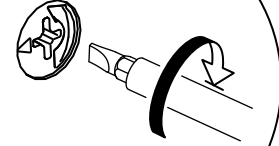
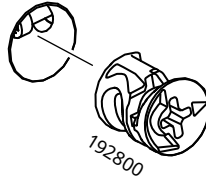

19

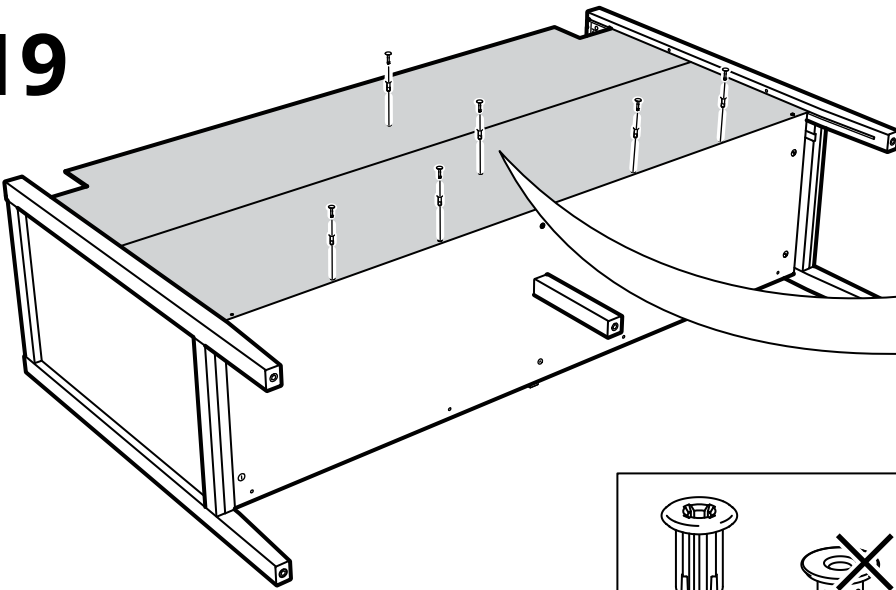

6x

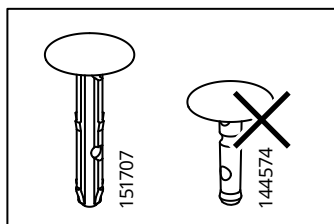
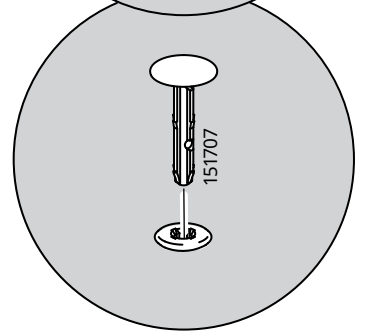
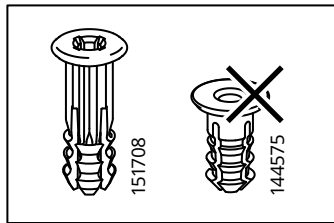

20

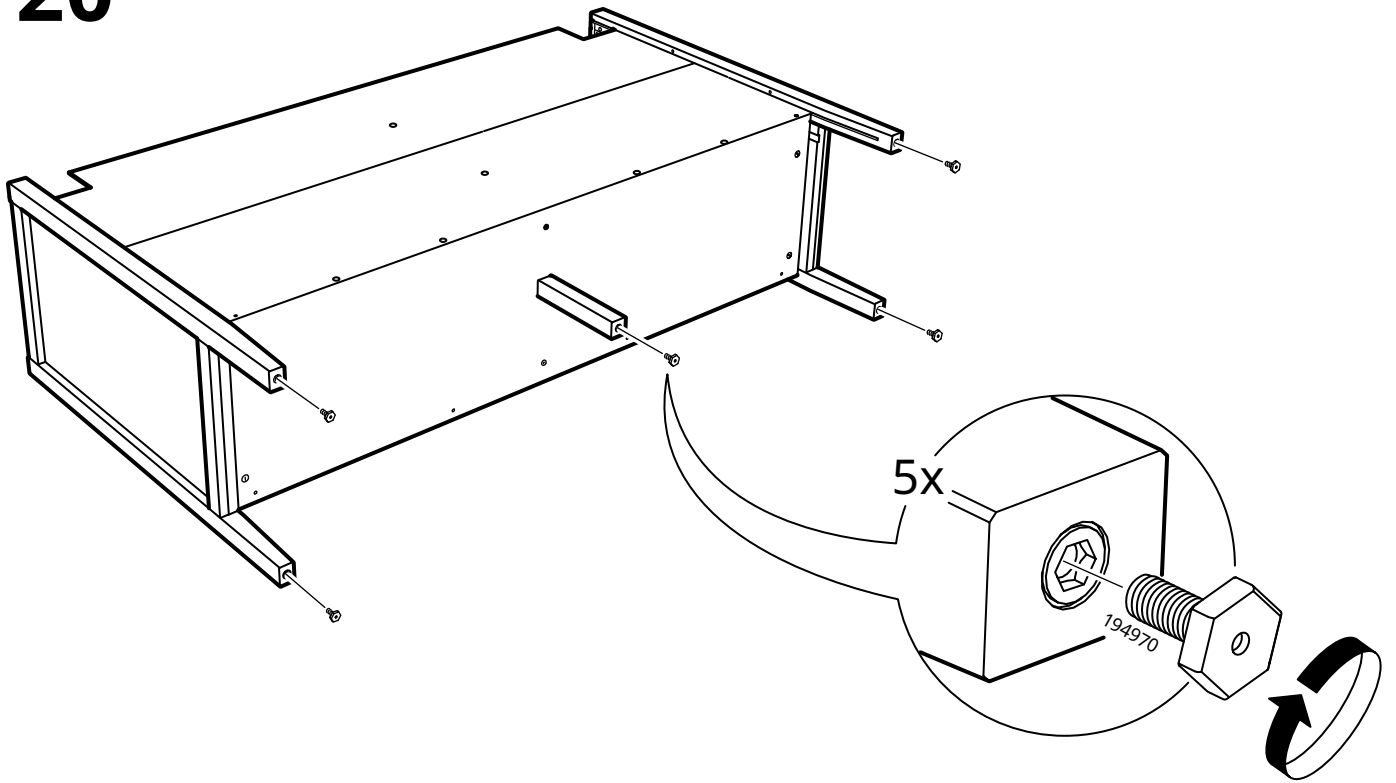

21

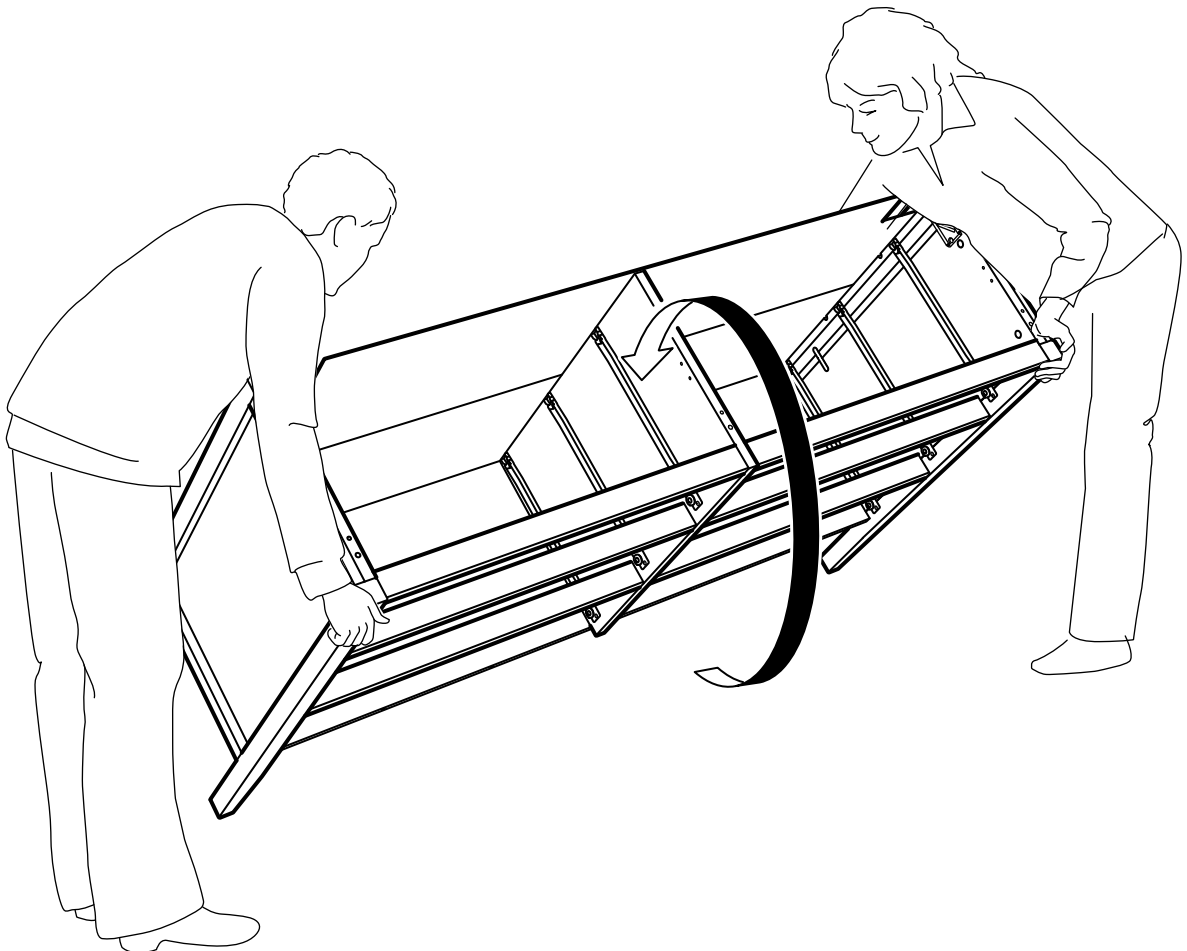

22

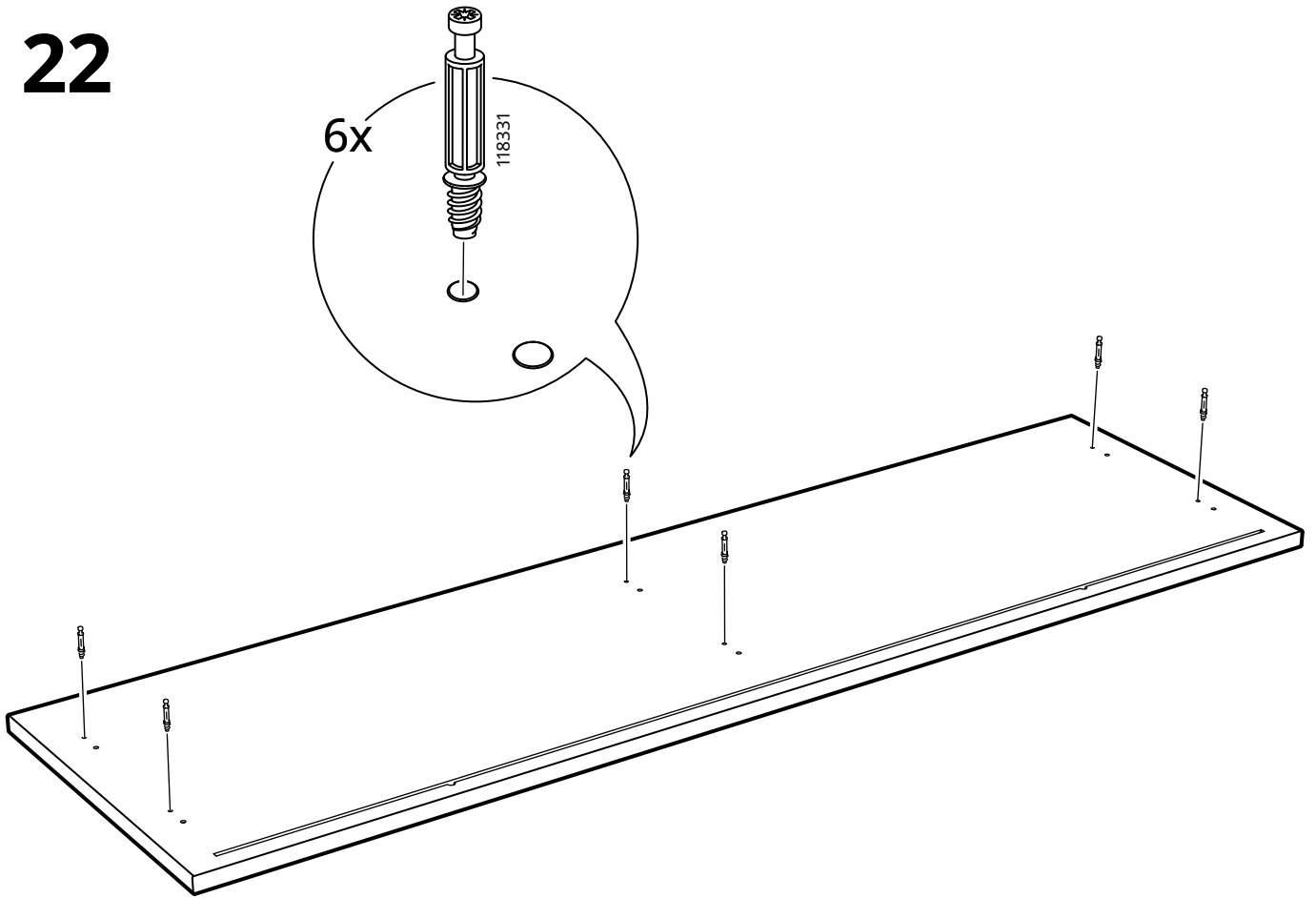

23

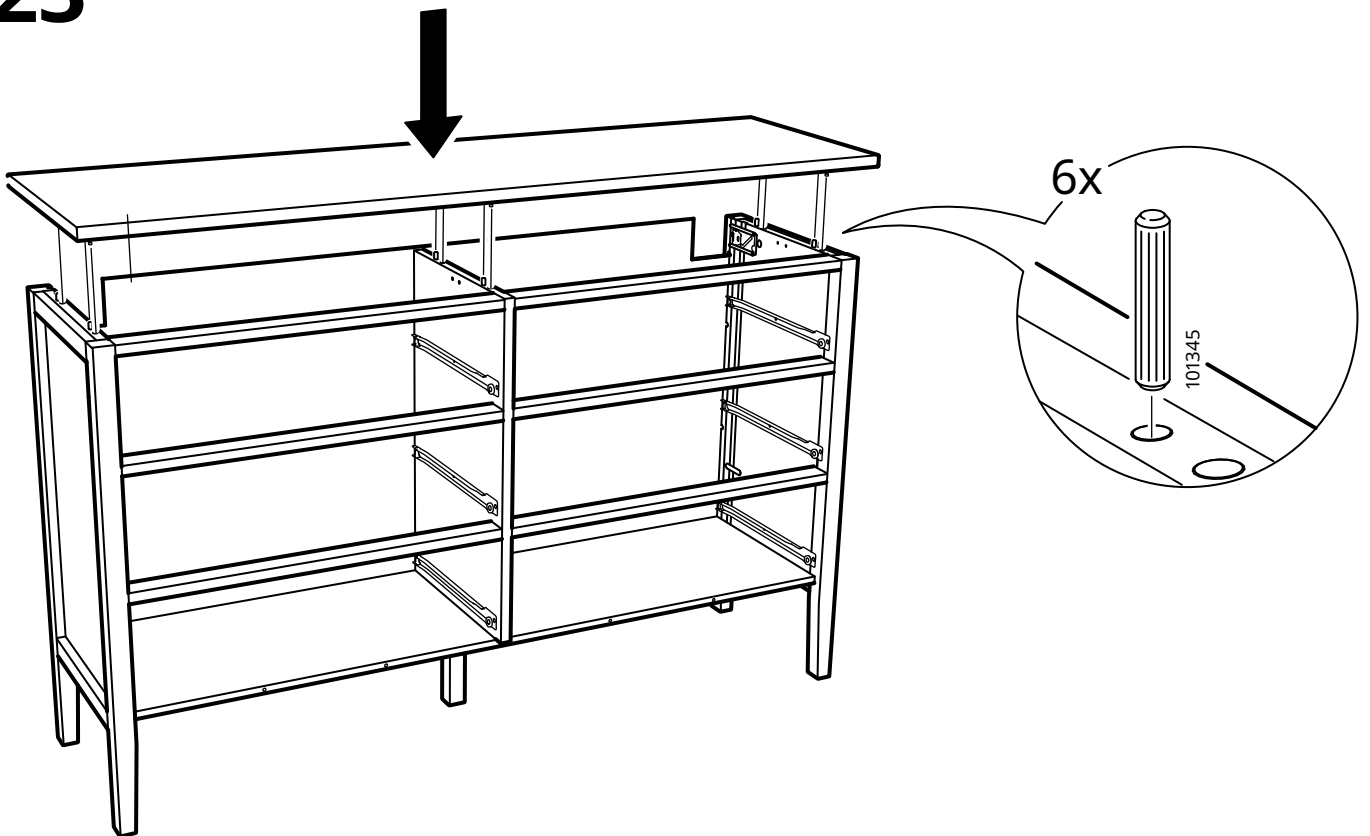

24

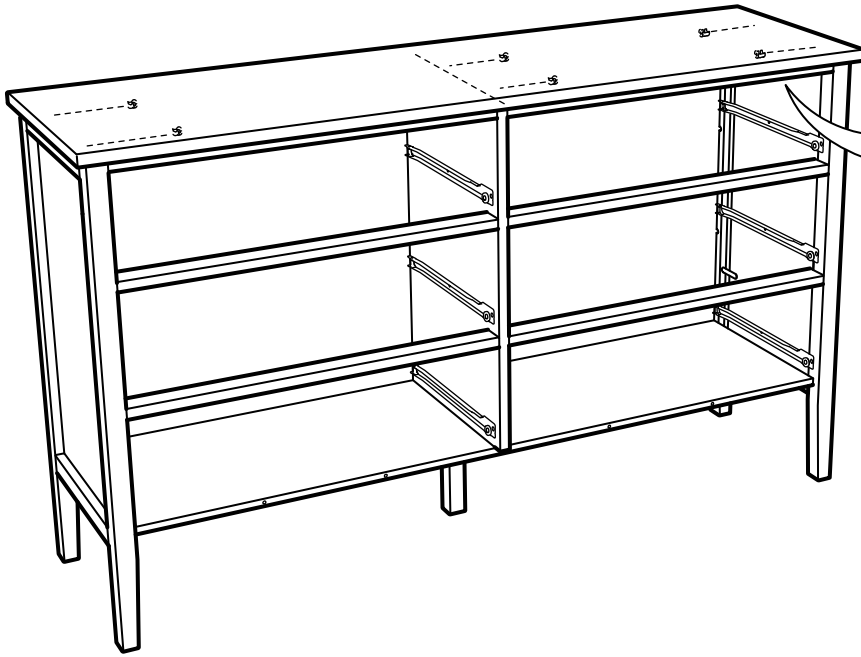

6x

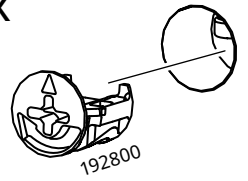

192800

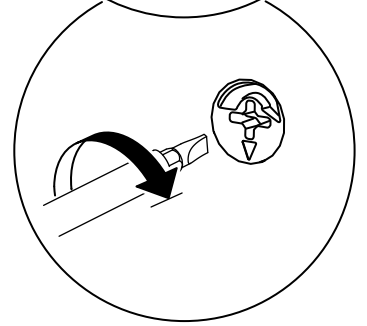

25

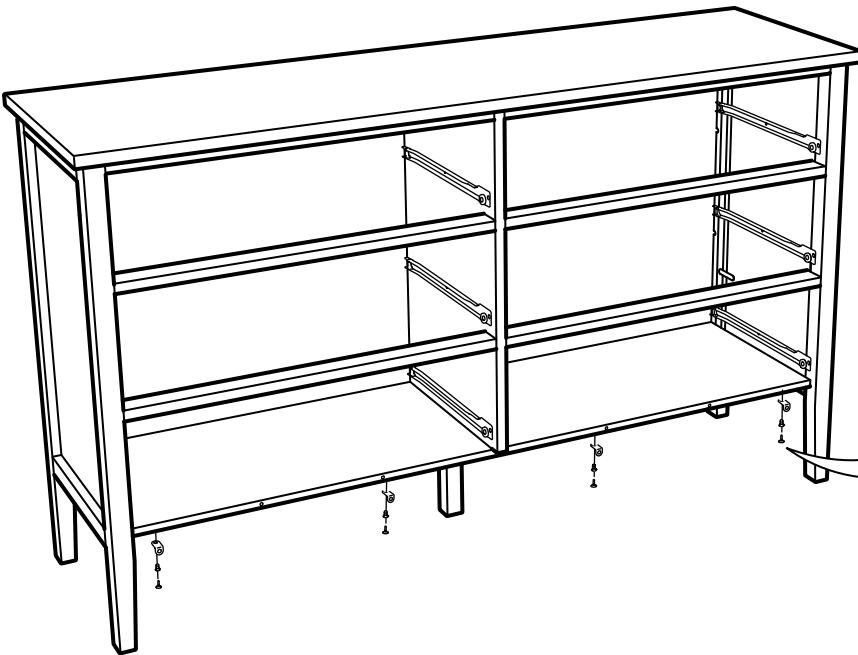

4x

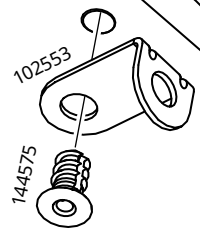

102553

144575

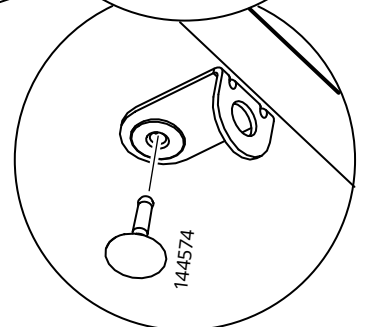

144574

26

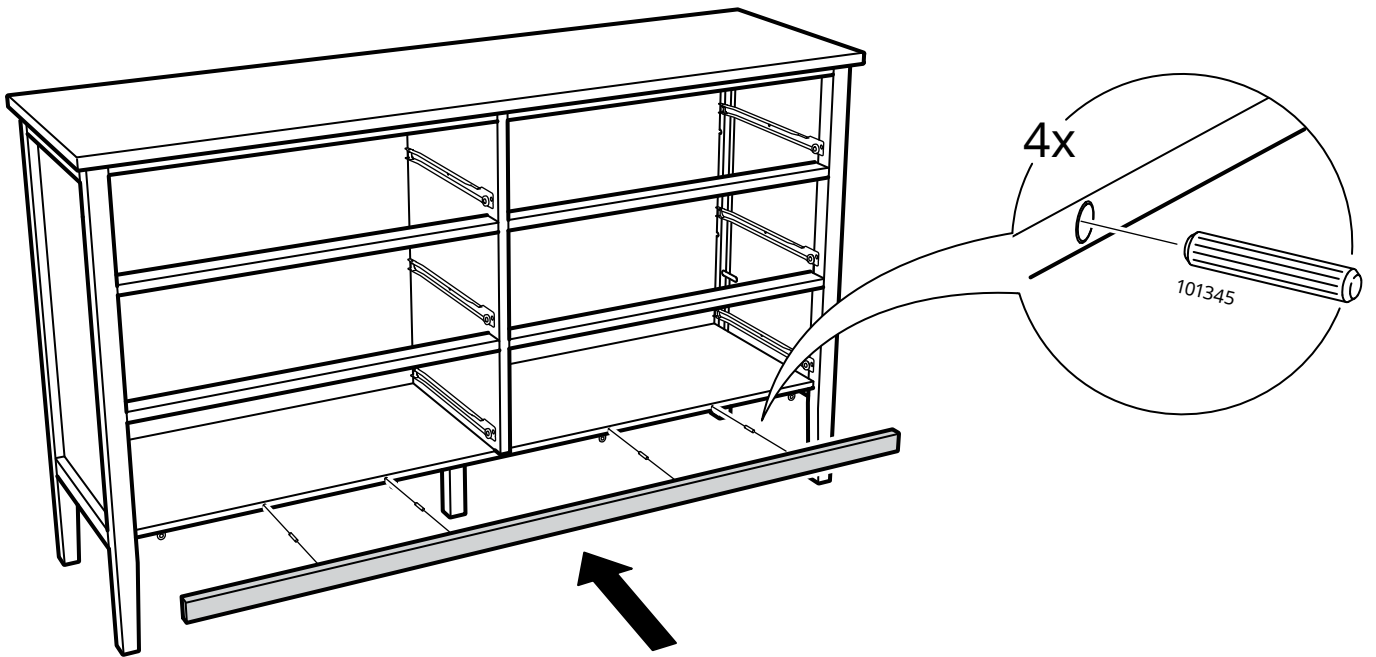

27

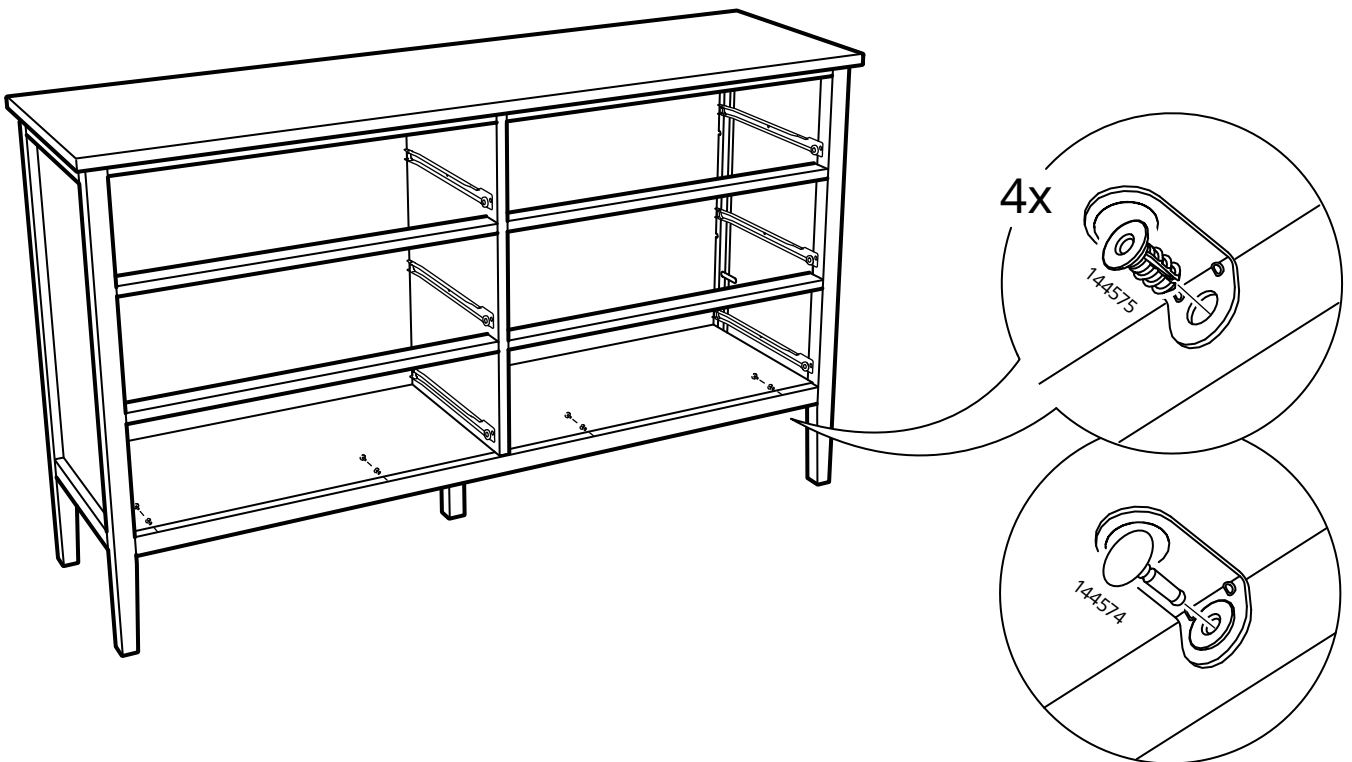

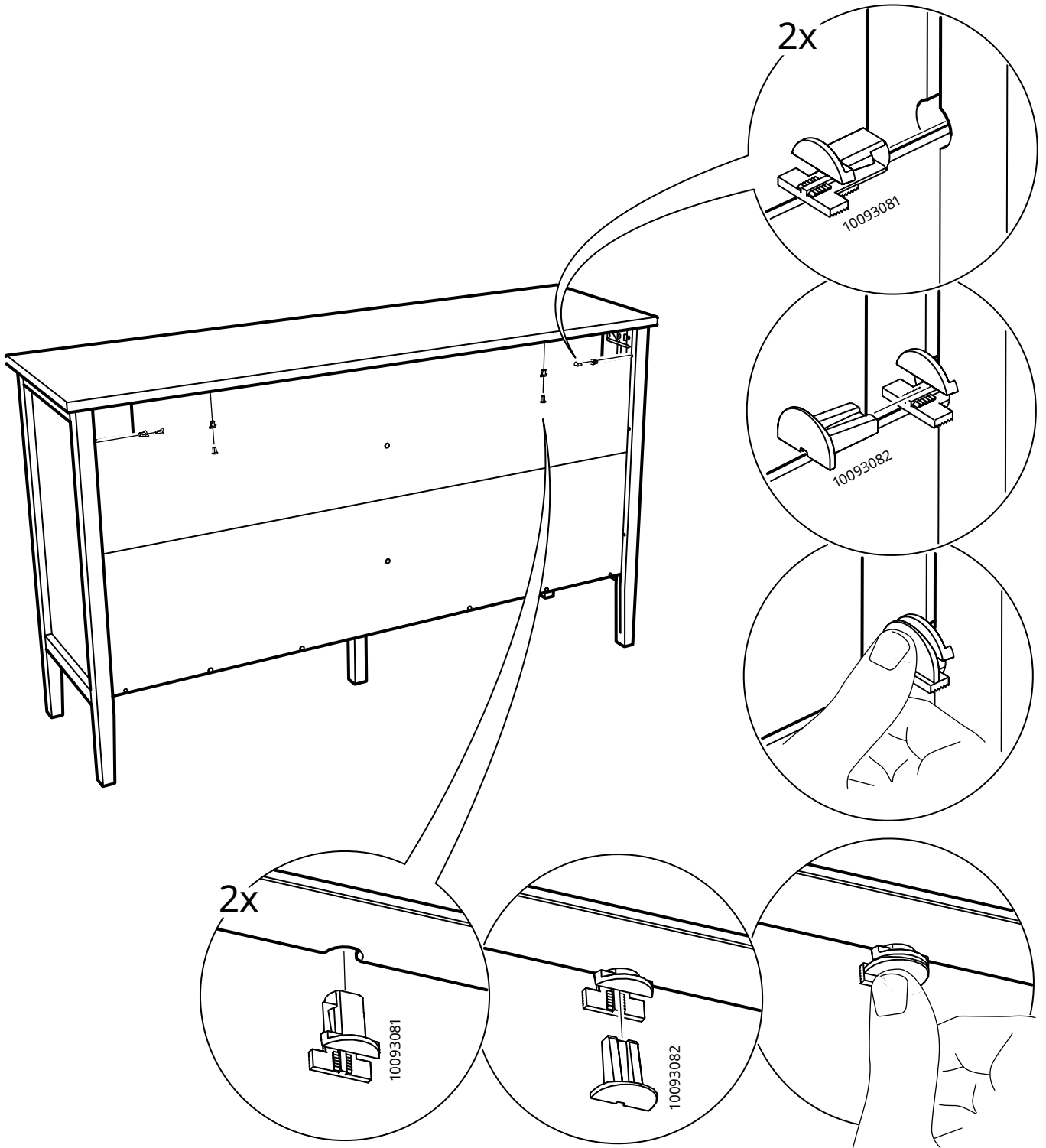

29

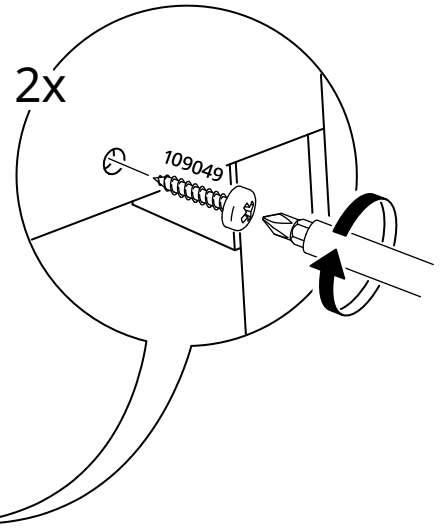
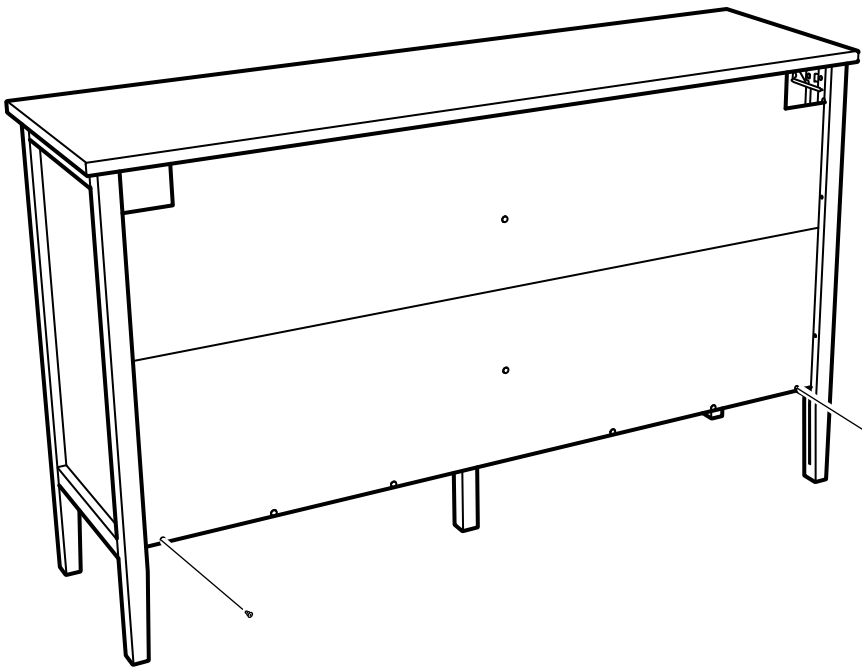

30

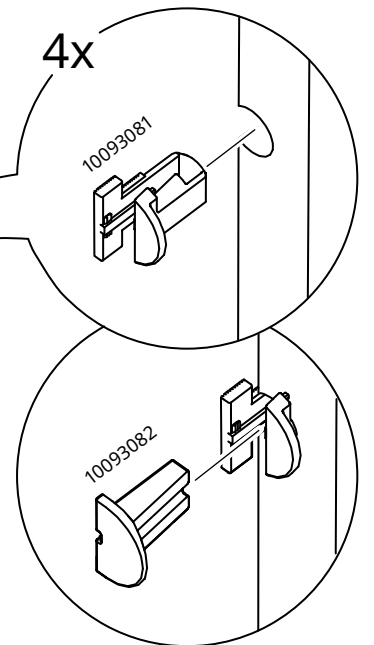
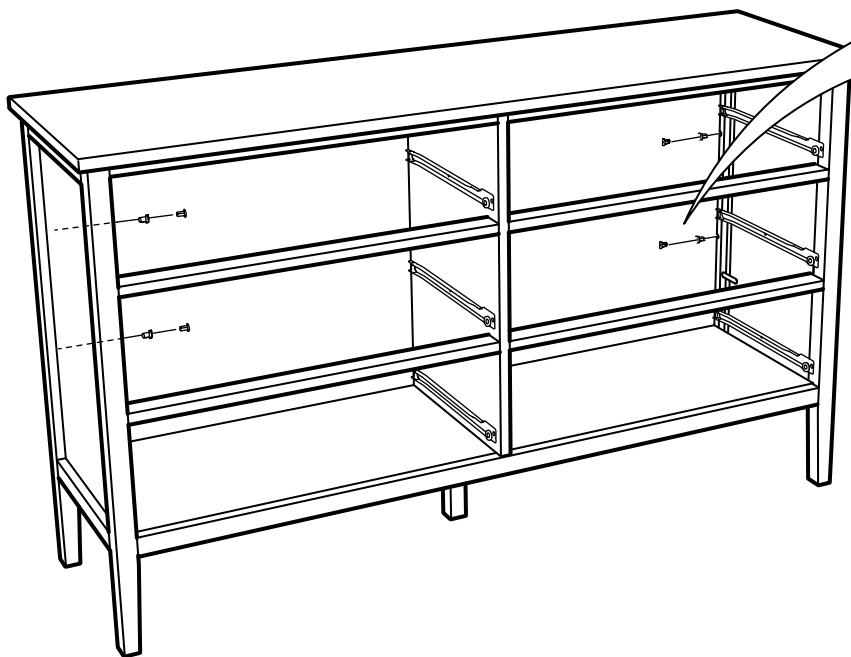

31

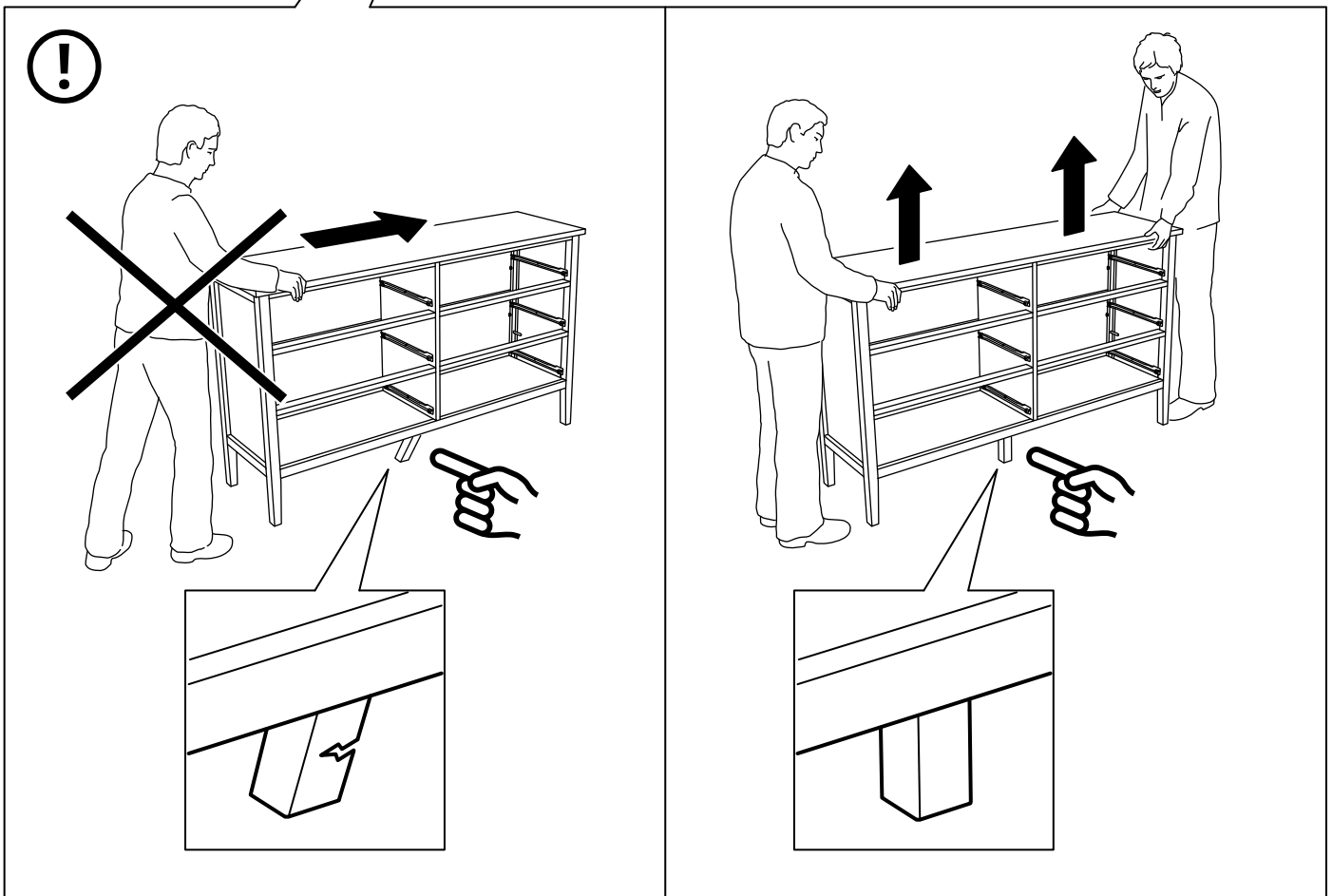
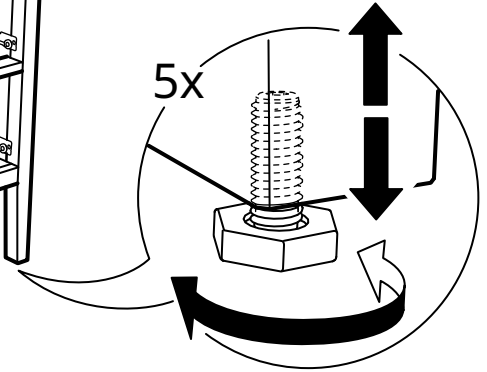
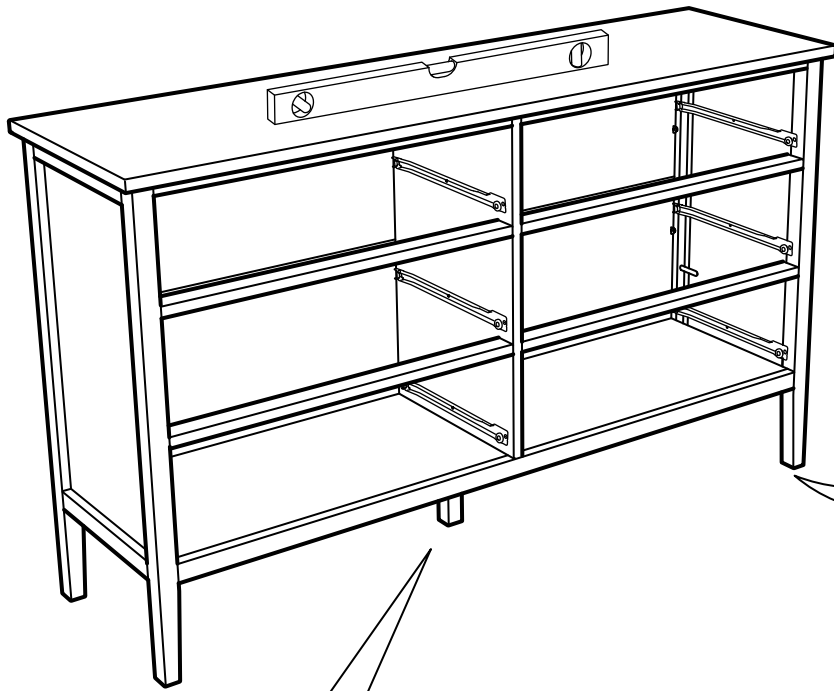

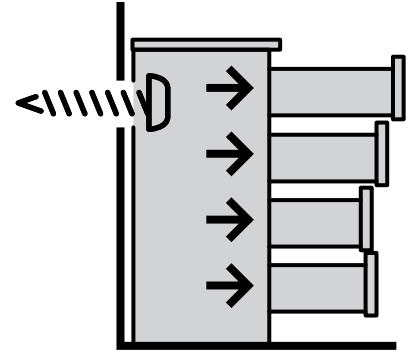
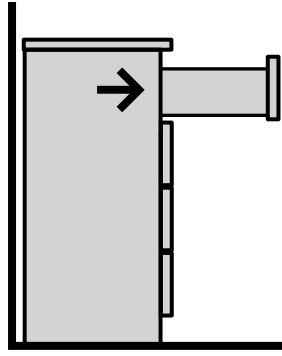
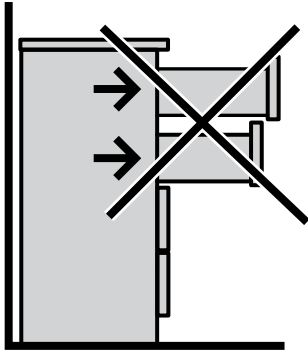

32

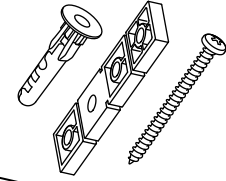
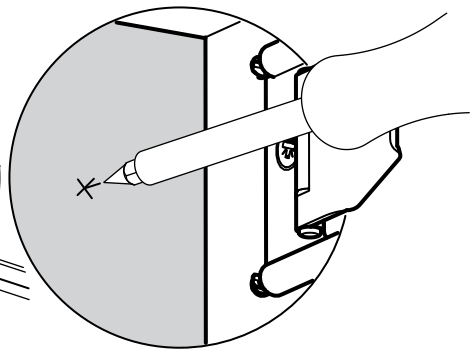
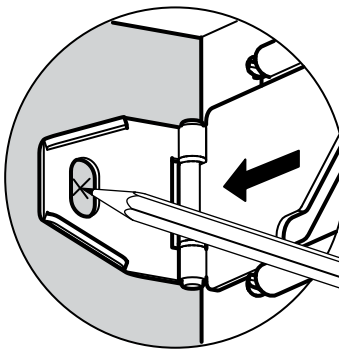
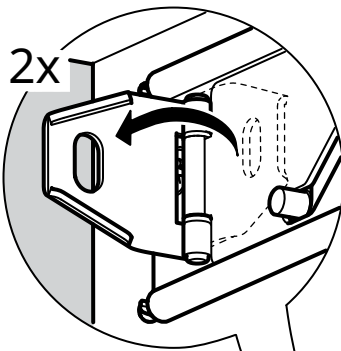

MADE IN SWEDEN
50 2012 27 000001

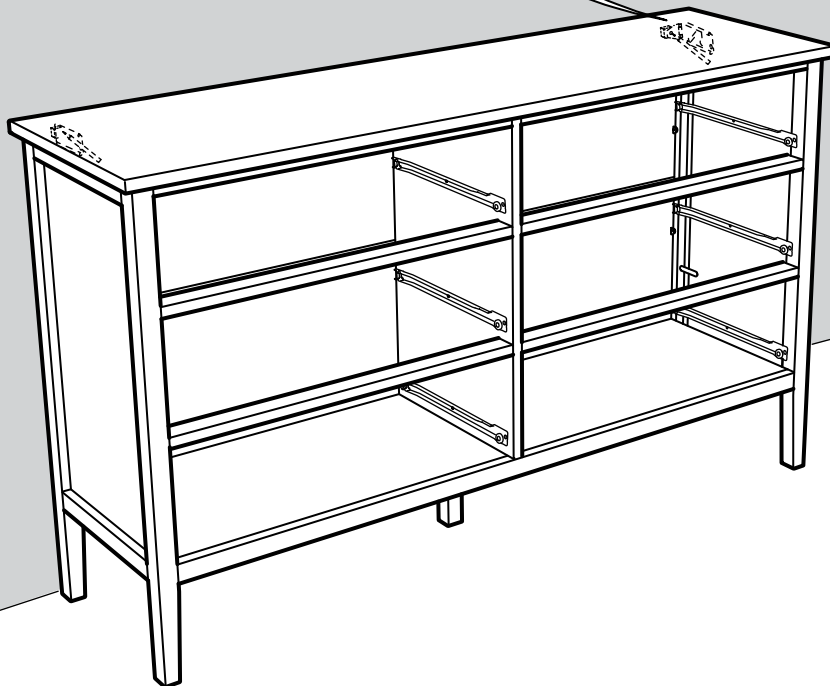

33

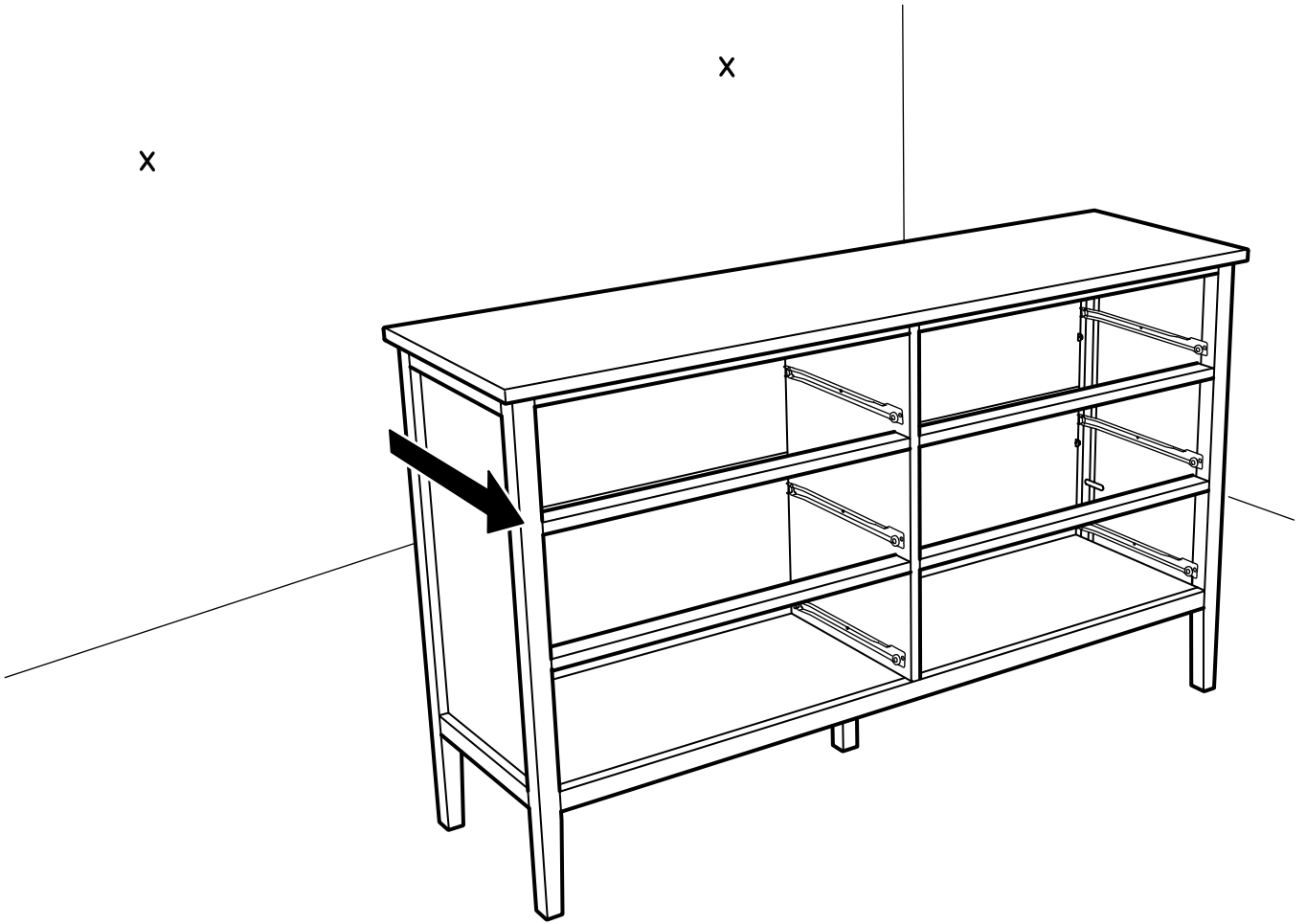

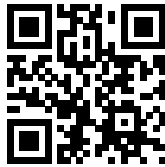

www.IKEA.com/secure-it

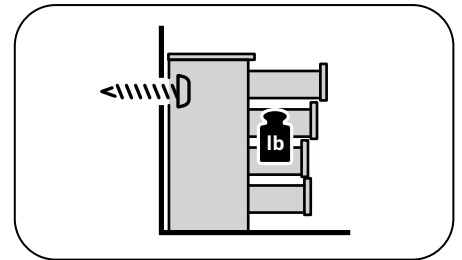

34

English

The screw(s) and plug(s) supplied can be used with most solid (A) and hollow (B) walls. For solid wood (C) use the screw(s) without plug(s). If you are uncertain, seek professional advice.

Français

Les vis et les chevilles fournies peuvent être utilisées avec la plupart des murs pleins (A) ou des murs creux (B). Pour le bois massif (C), utiliser les vis sans les chevilles. En cas de doute, adressez-vous à un professionnel qualifié.

Español

Los tornillos y tacos incluidos se pueden utilizar en la mayor parte de las paredes sólidas (A) o huecas (B). Para la madera maciza (C), usa los tornillos sin tacos. Si tienes dudas, acude a un experto.

A

Ø 5/16" (8 mm)

- 1
- 2 2 3/4" (70 mm)
- 3

B

Ø 5/16" (8 mm)

- 1
- 2 ≈ 1 1/4" (≈ 30 mm)
- 3

C

Ø 1/8" (3 mm)

- 1
- 2 ≈ 1 1/4" (≈ 30 mm)
- 3

35

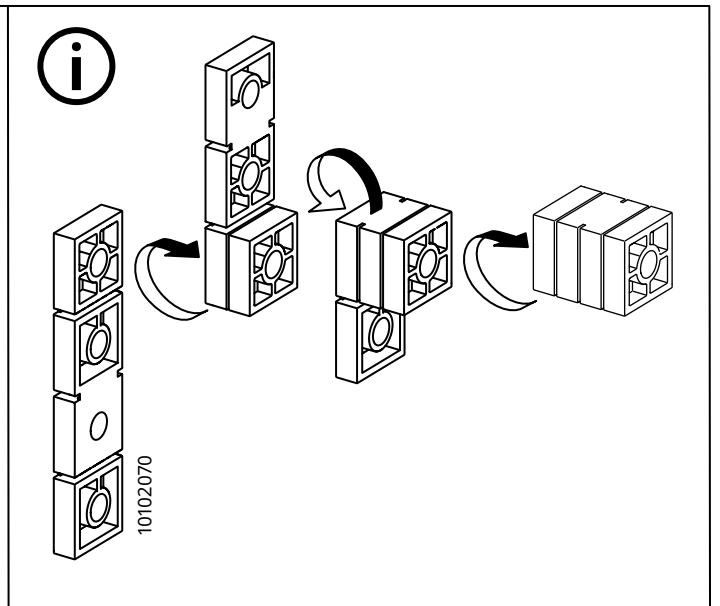
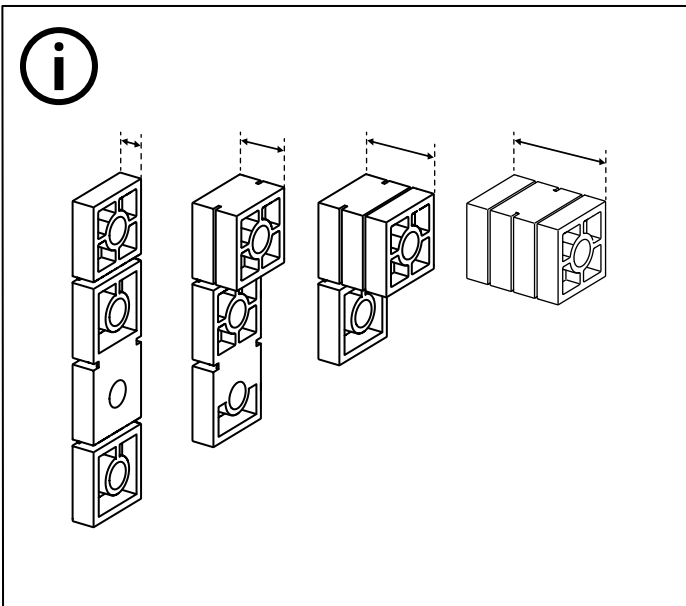
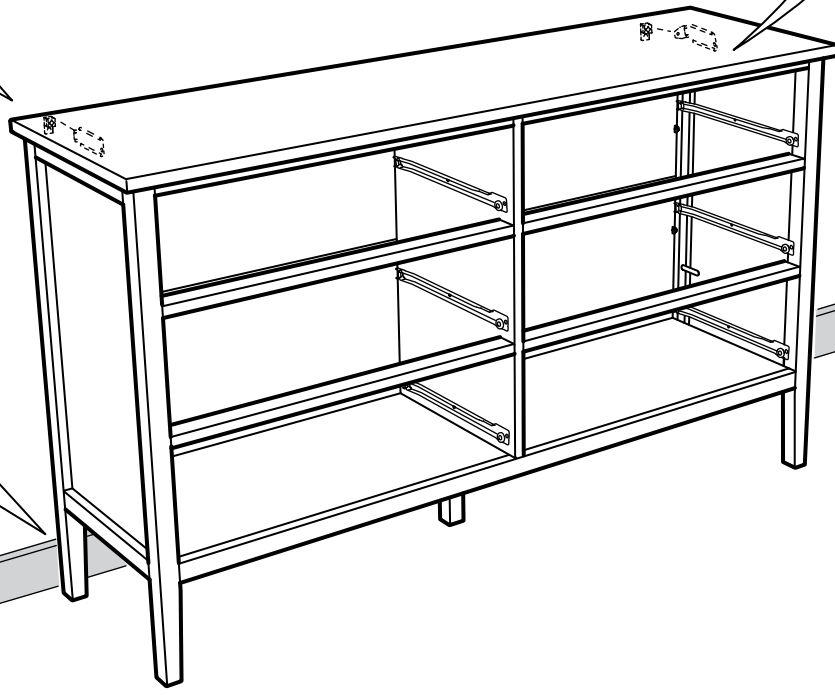
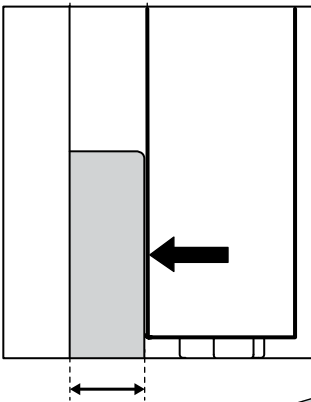
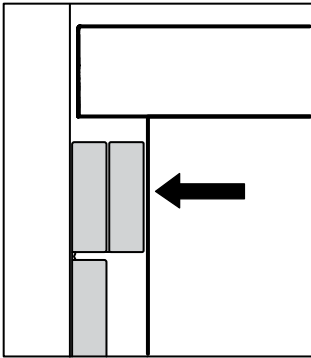
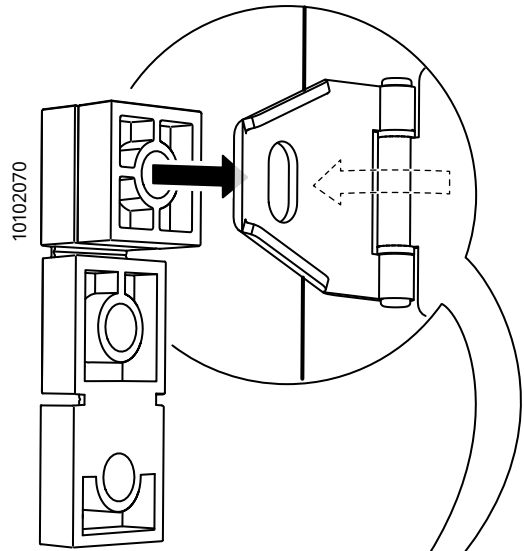
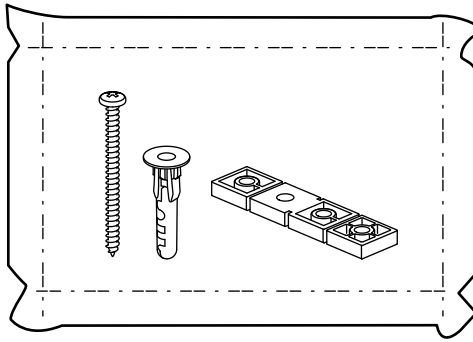

36

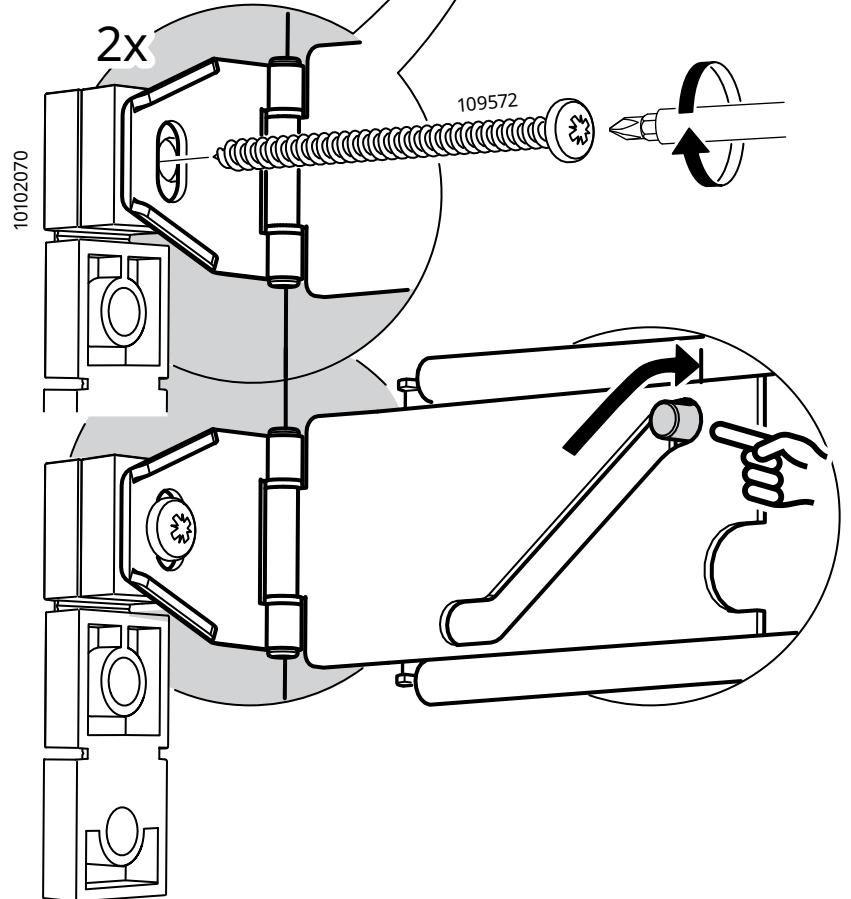
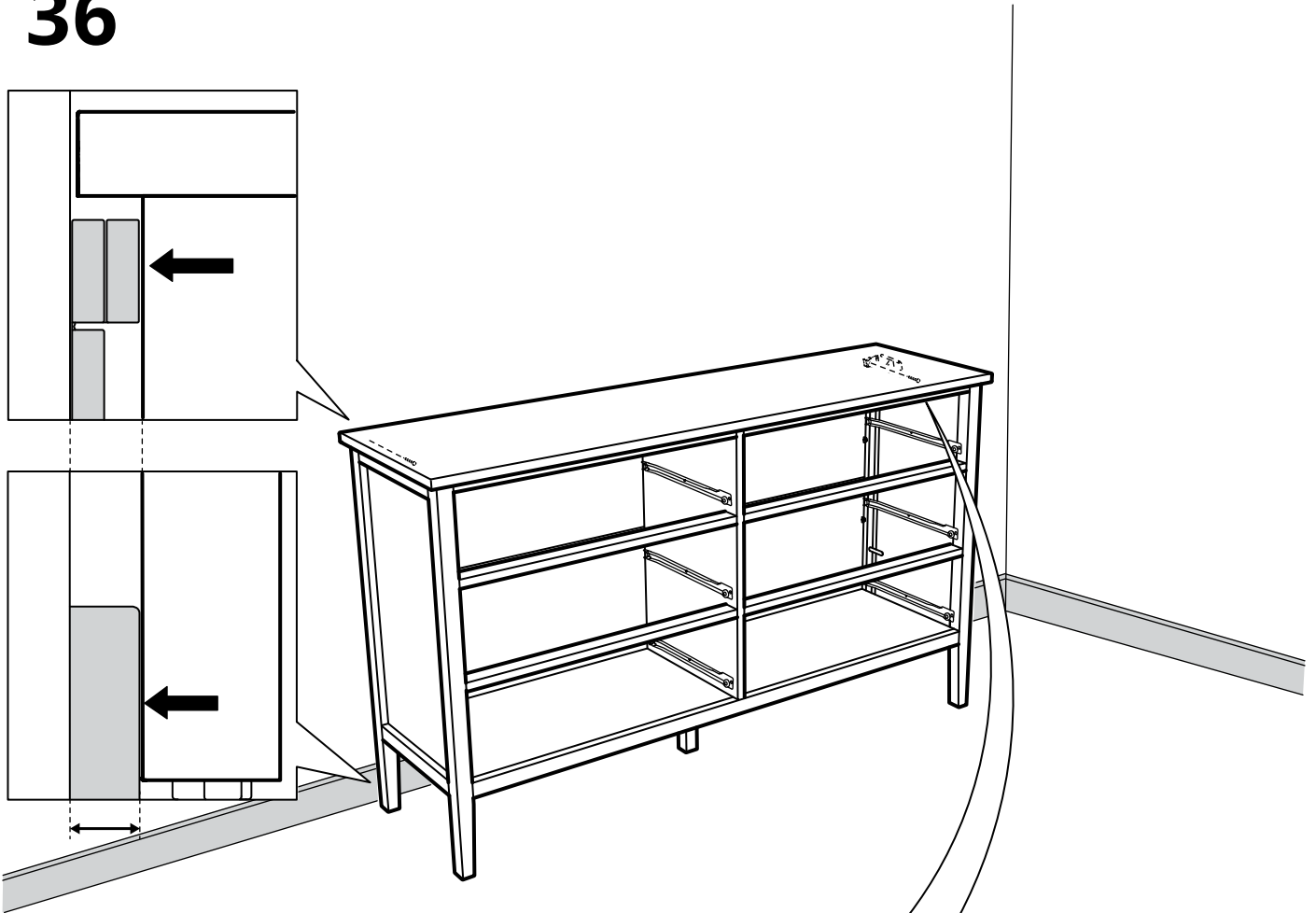

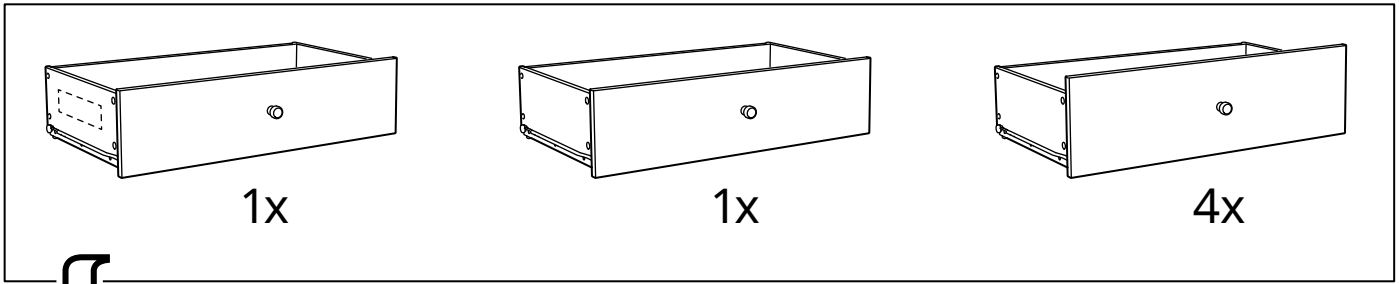

37

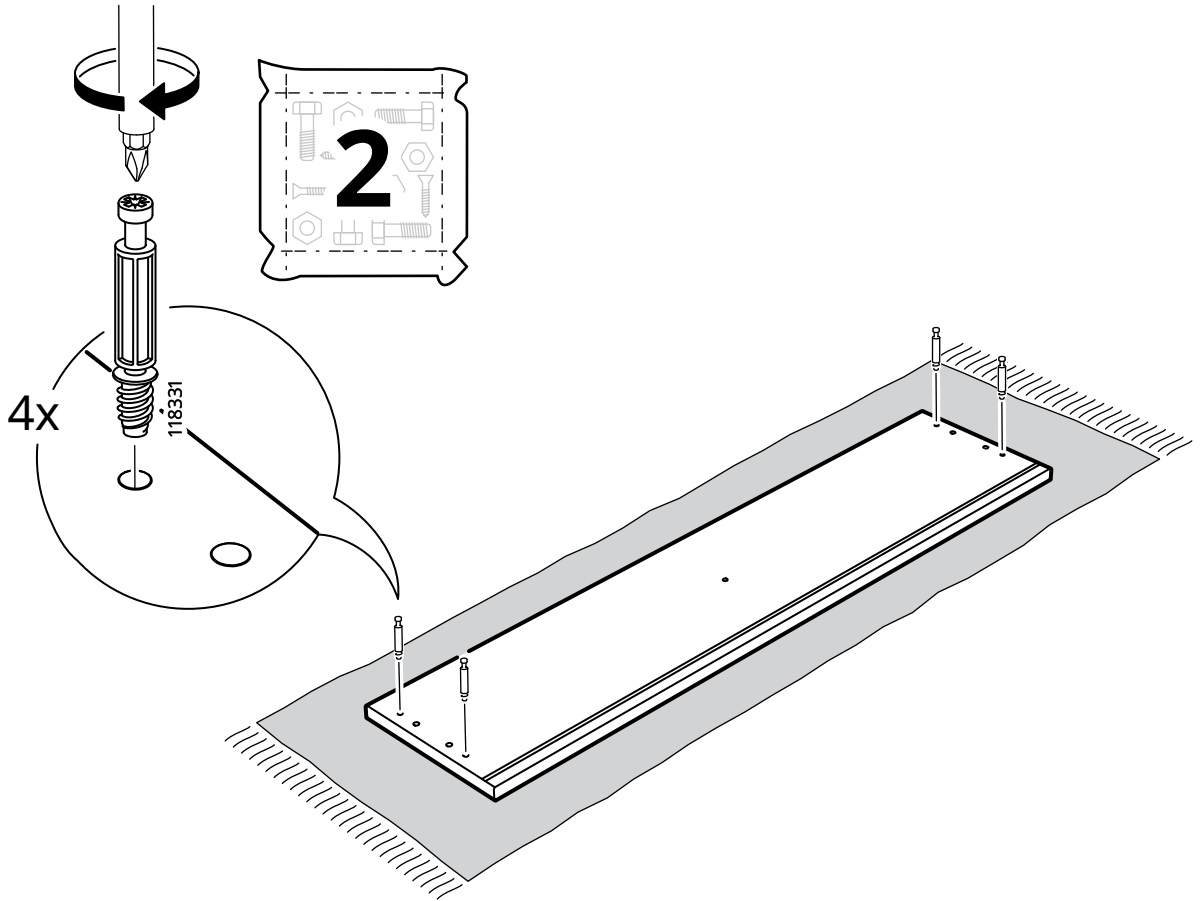

38

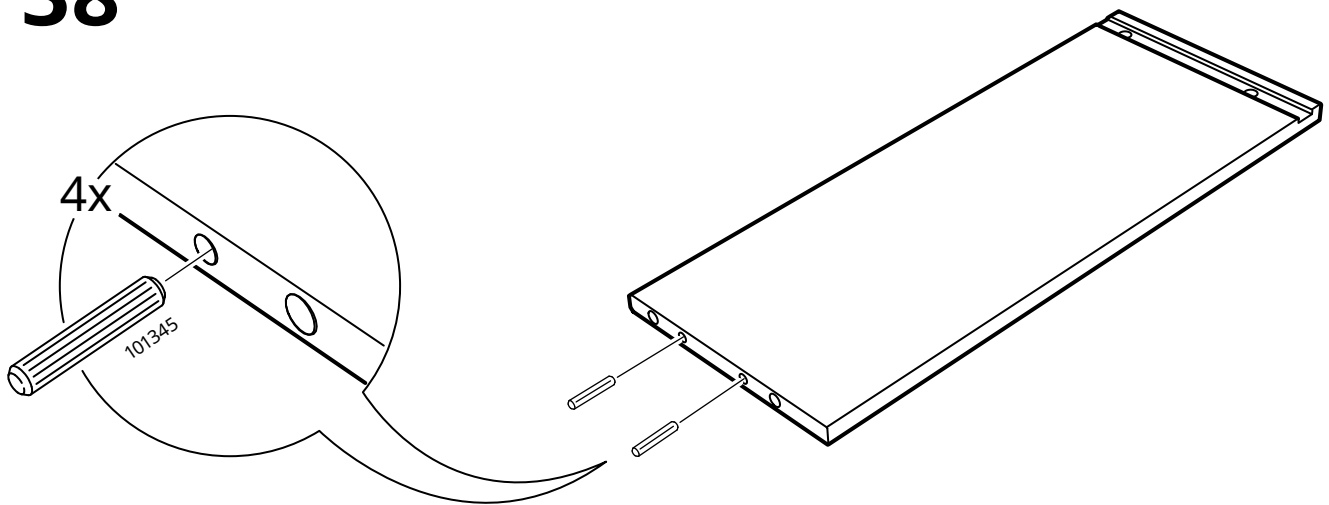

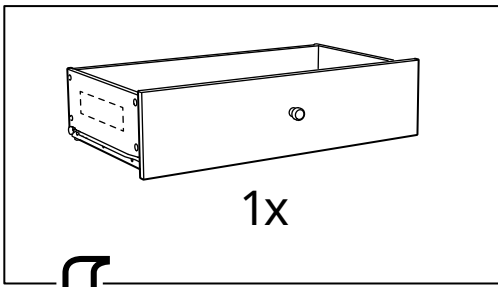

39

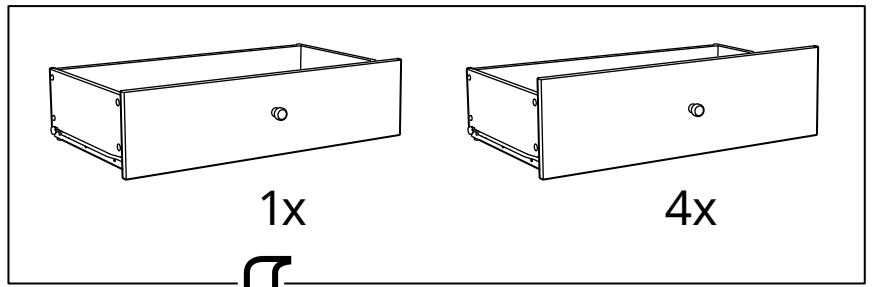

36

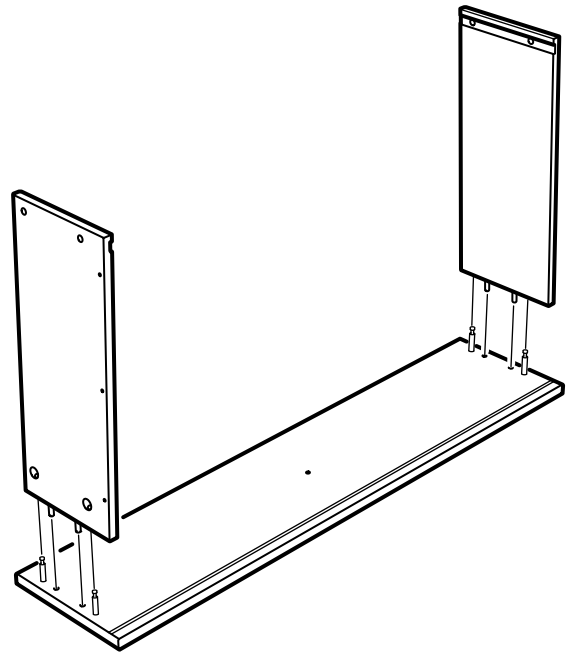
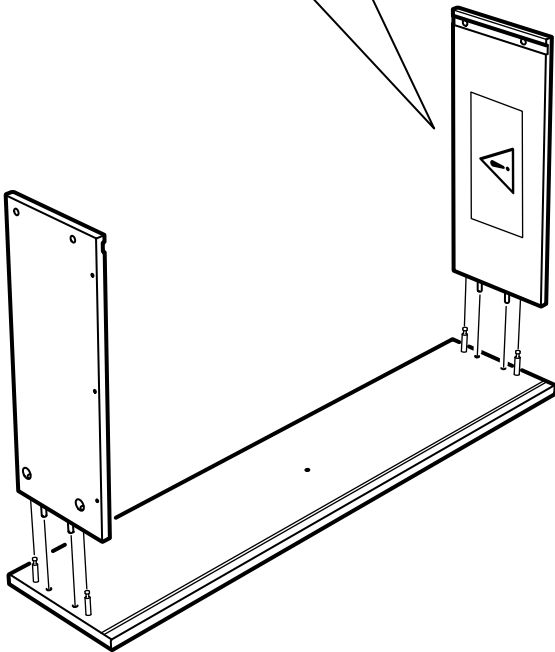
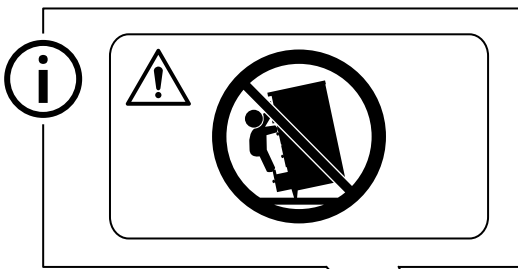

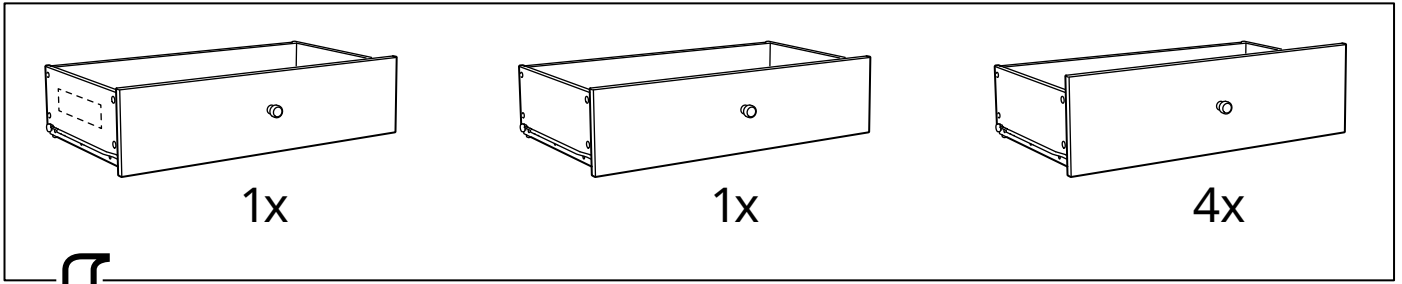

40

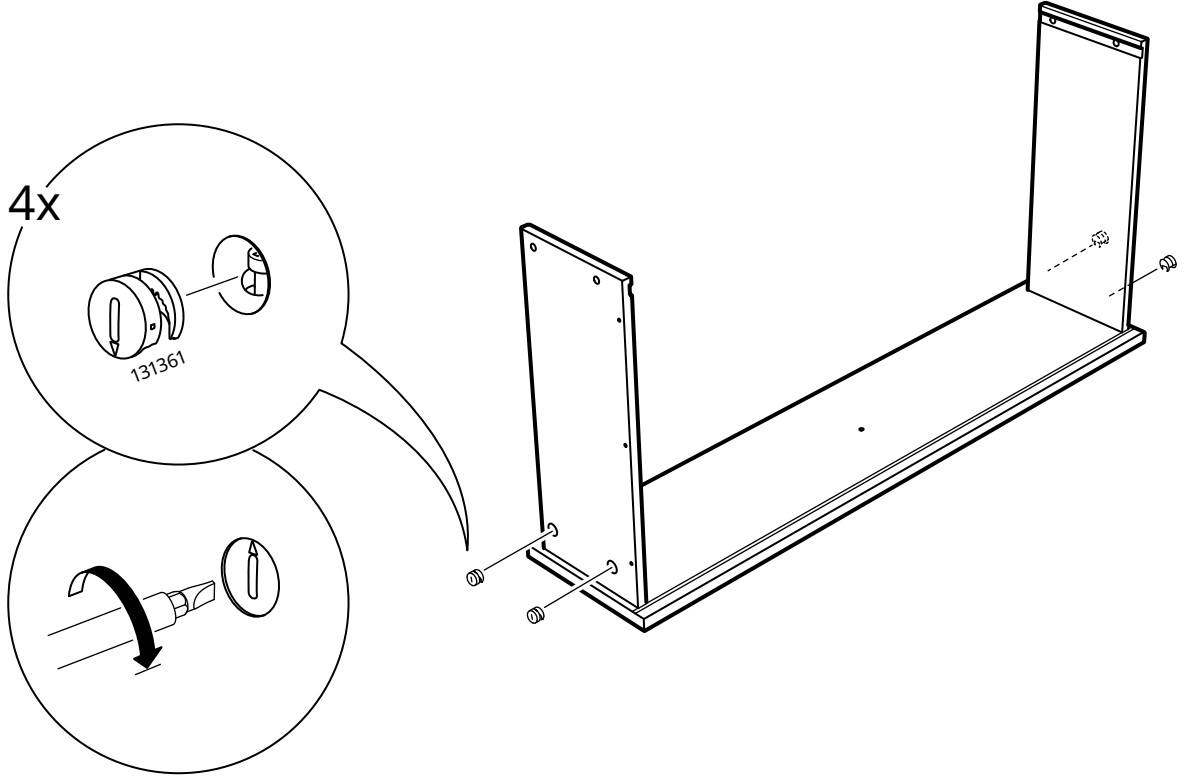

41

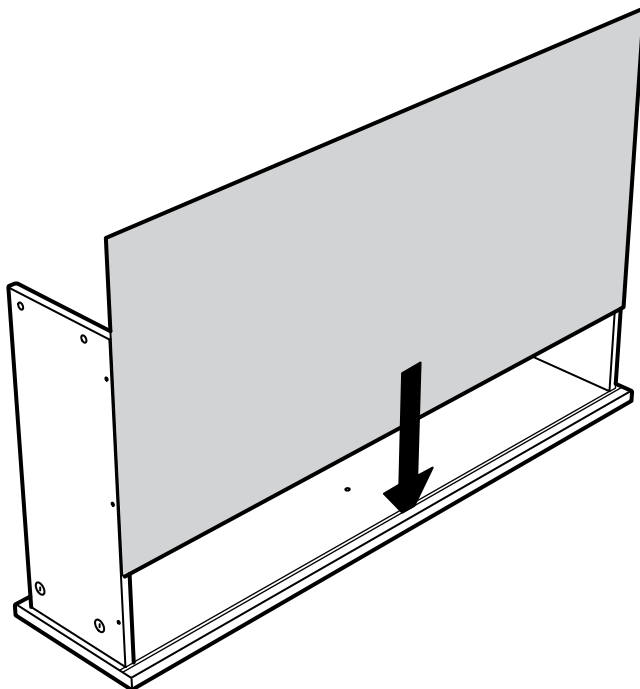

42

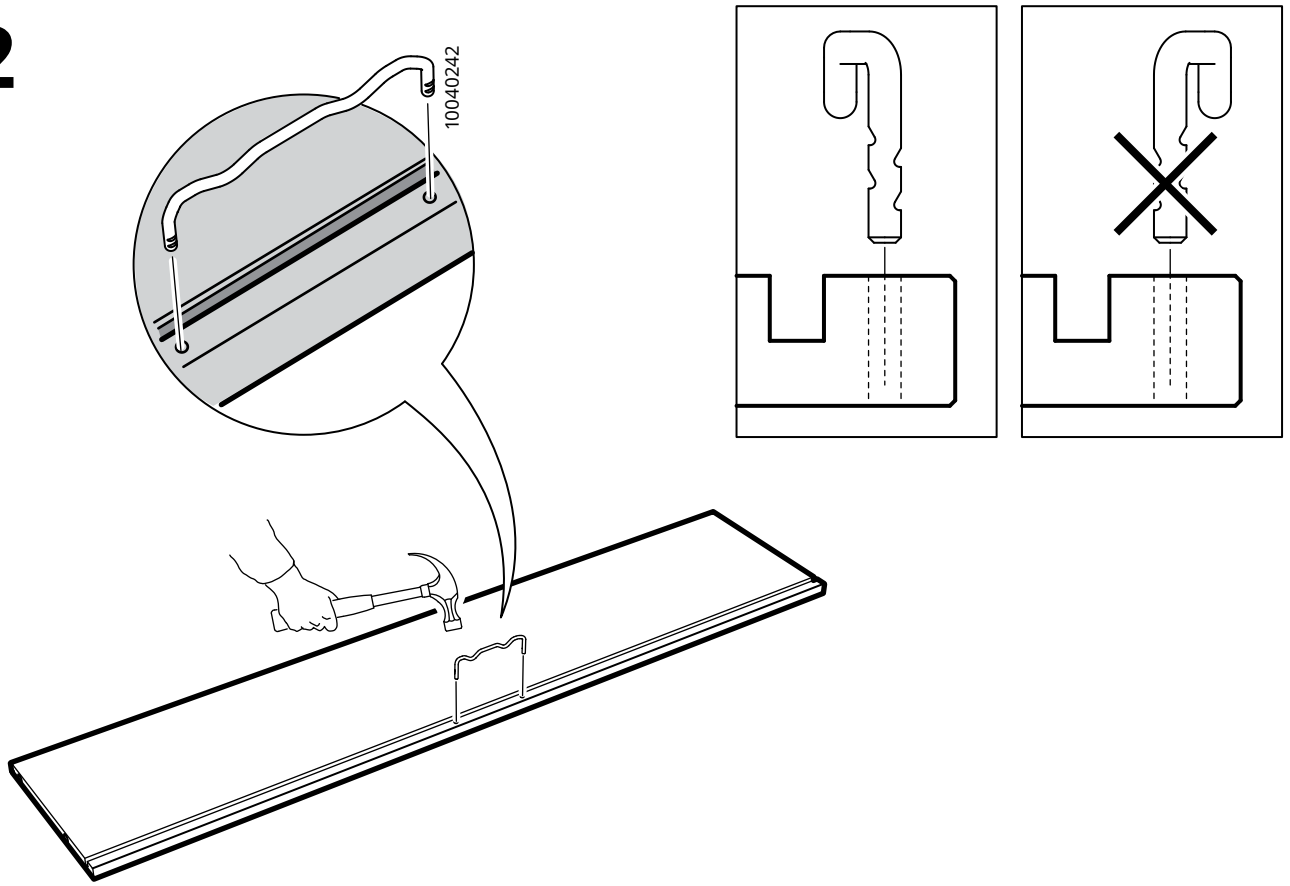

43

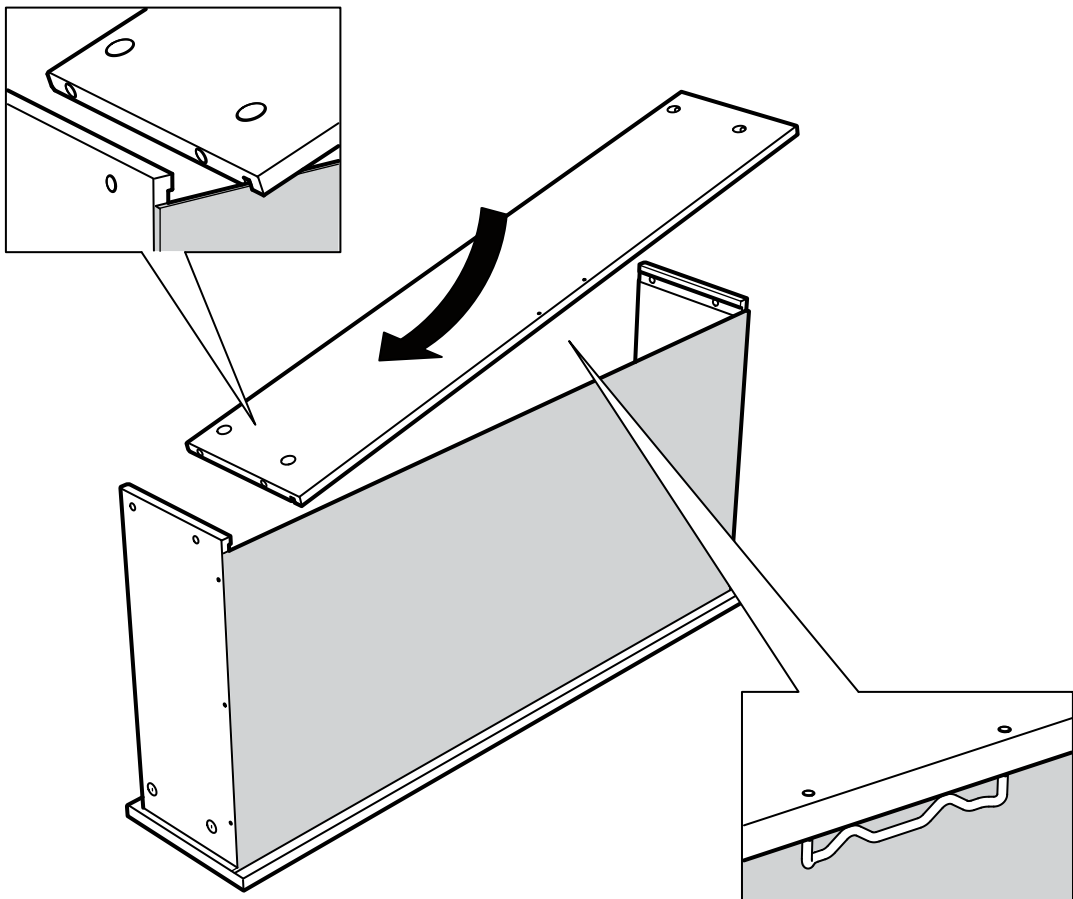

44

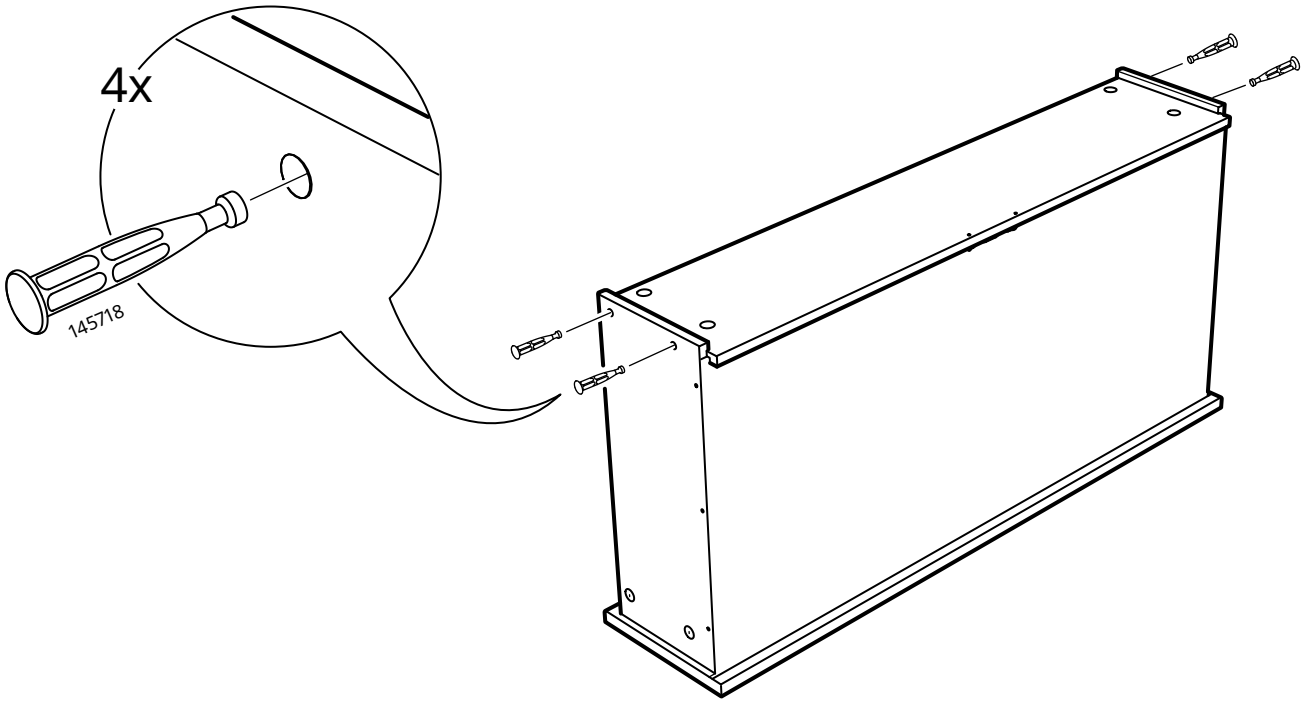

45

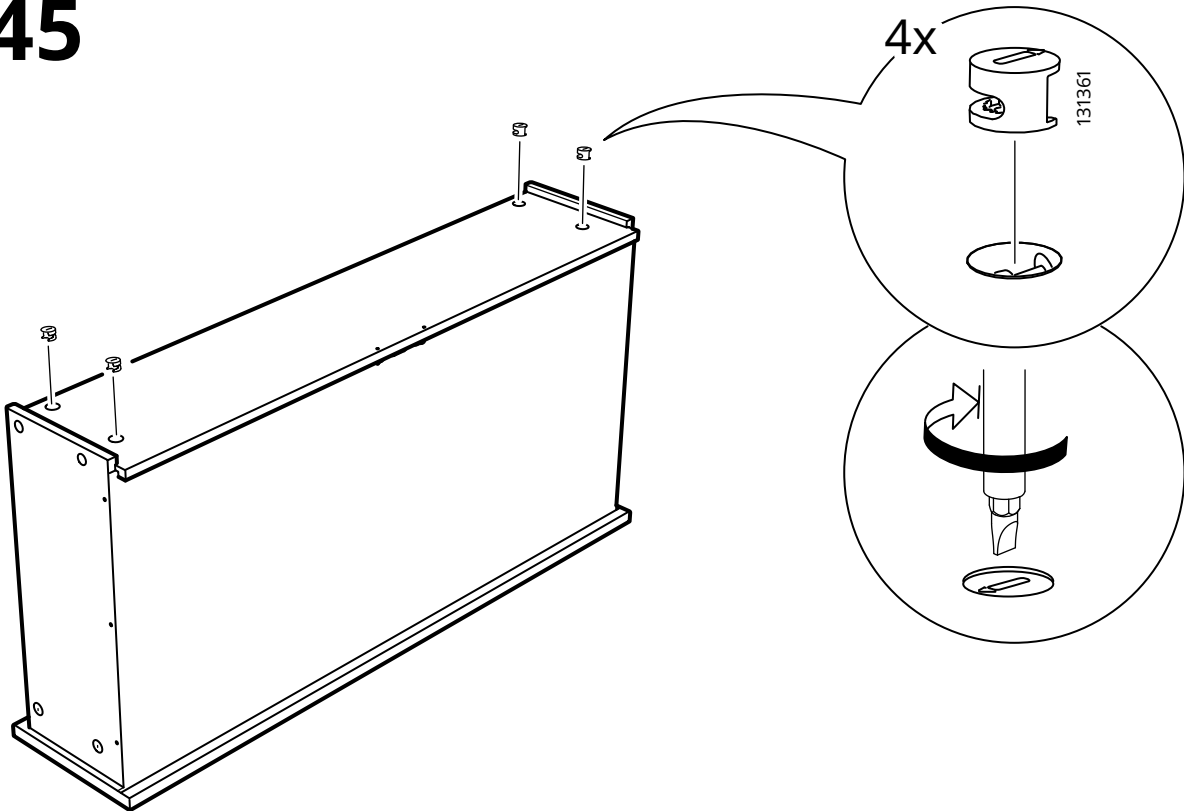

46

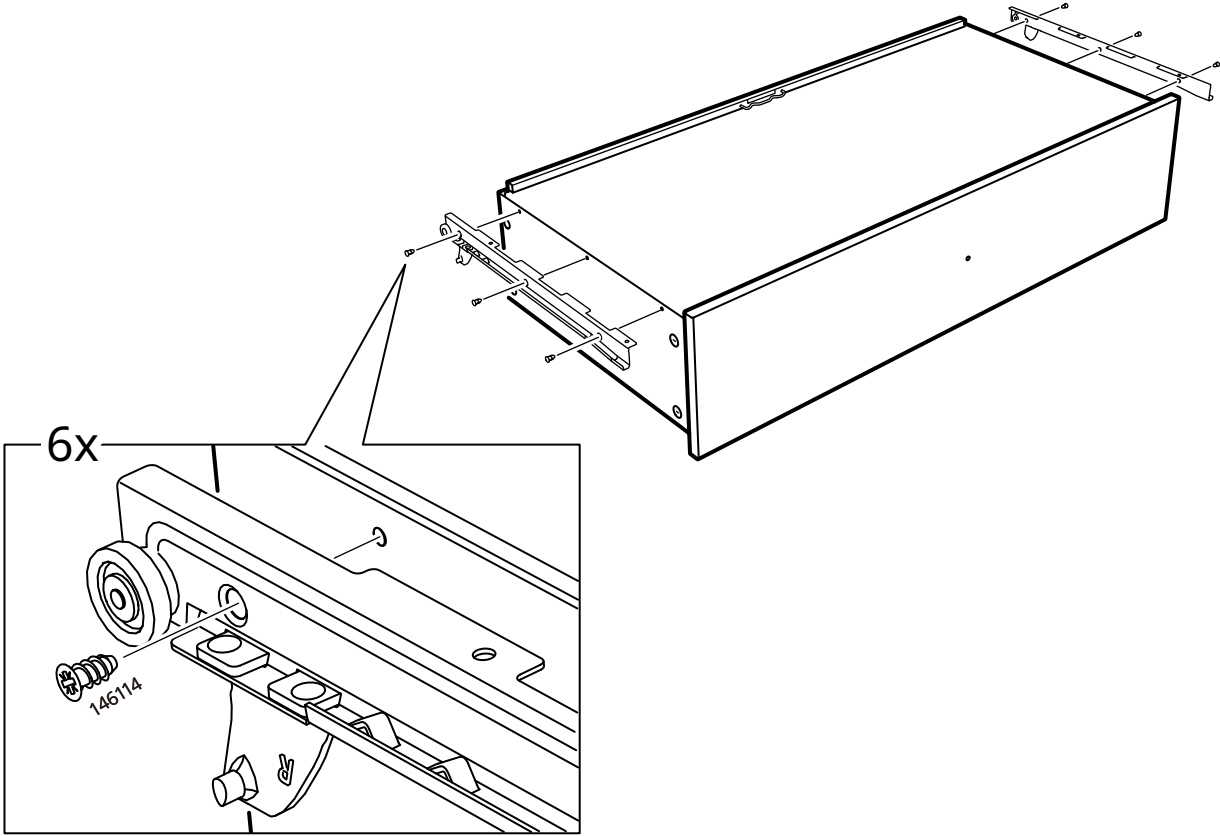

47

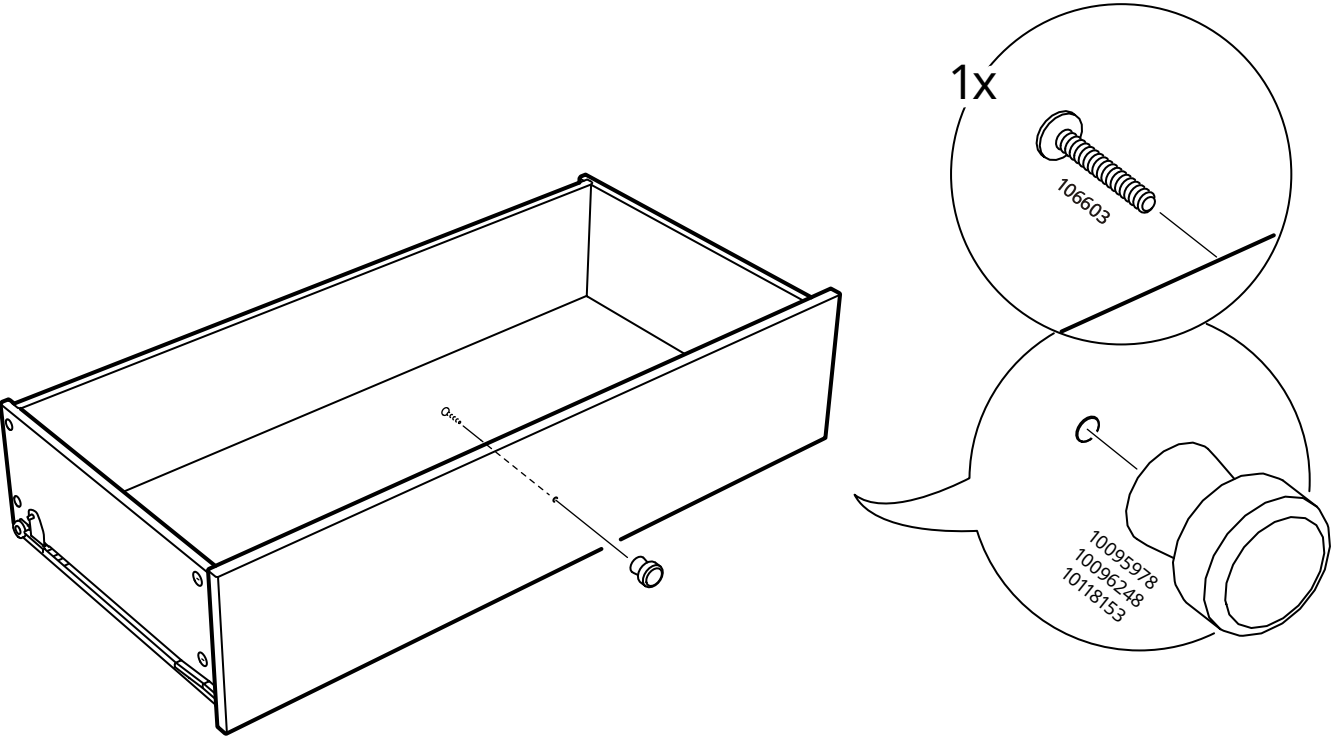

48

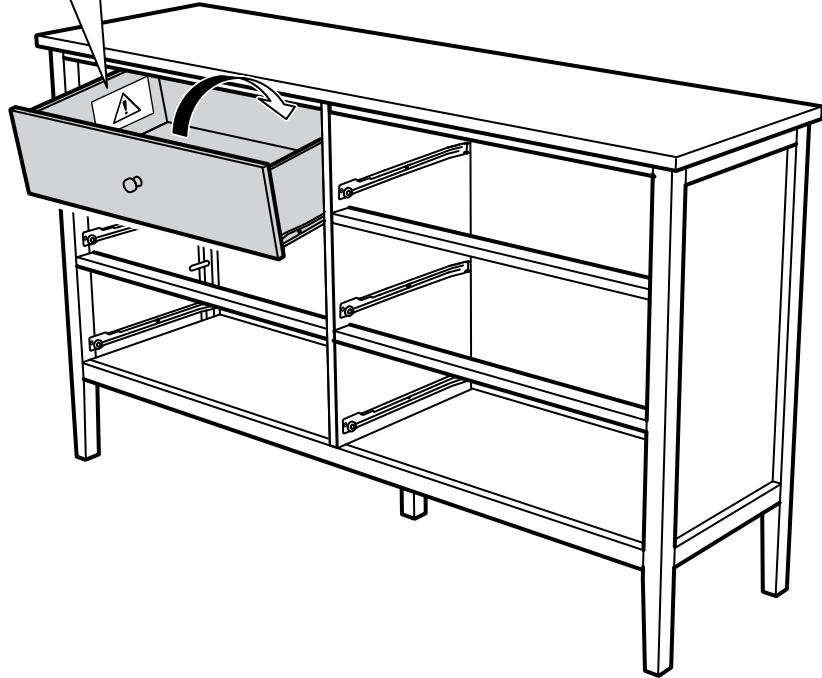
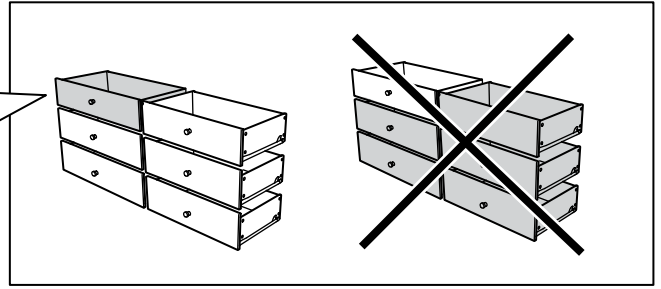

49

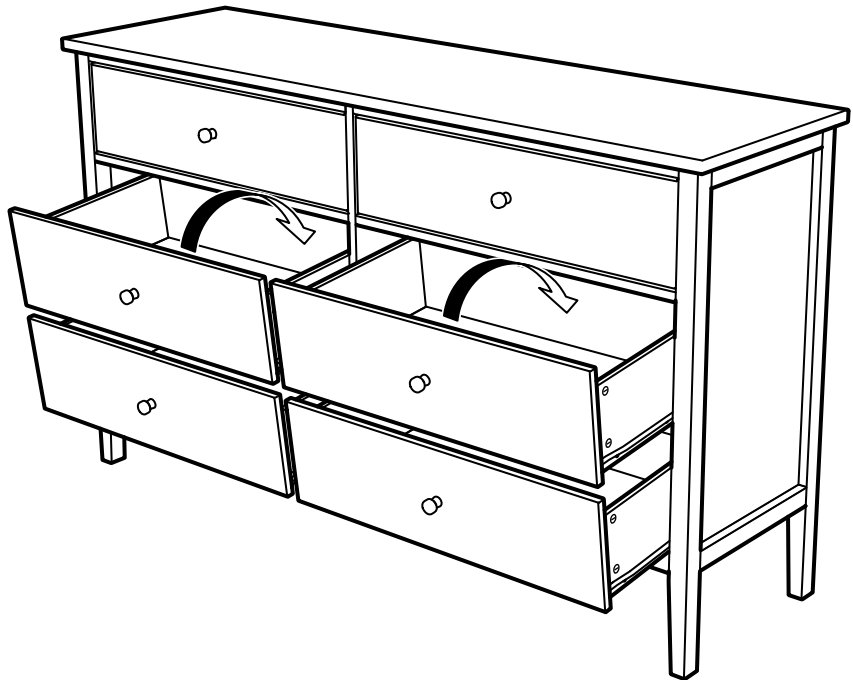
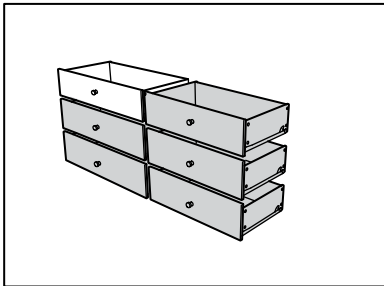



1

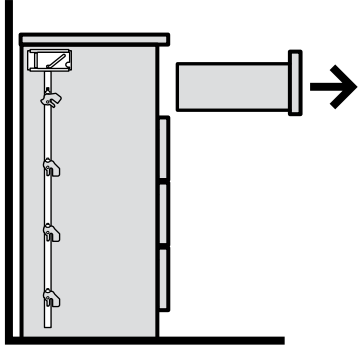

2

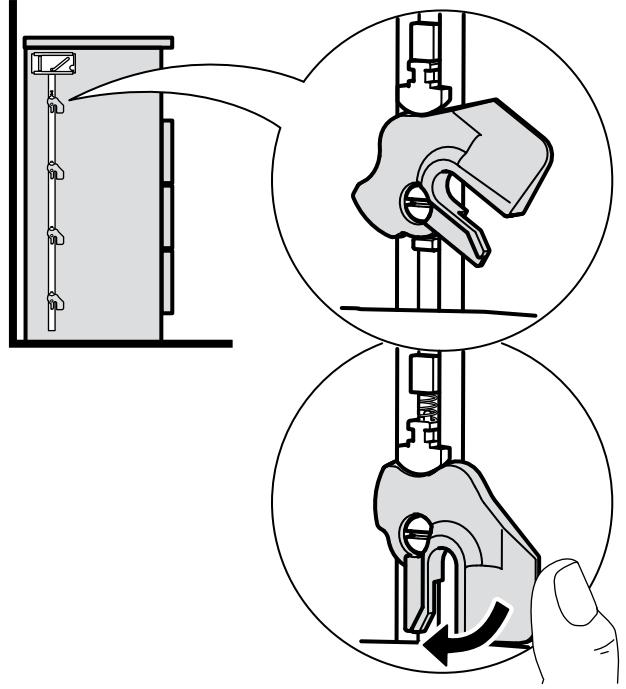

3

