

# STACKBO

en



Design and Quality  
IKEA of Sweden





Please refer to the last page of this manual for the full list of IKEA appointed Authorized Service Centre and relative national phone number.

## Contents

Safety information	4	Cleaning and maintenance	9
General information	7	What to do if...	11
Product description	8	Technical data	12
Control panel	8	Environmental aspects	13
General tips	9	IKEA guarantee	13

## Safety information

**i** For your own safety and correct operation of the appliance, please read this manual carefully before installation and operation. Always keep these instructions together with the appliance, even if it is sold or transferred to third parties. It is important that users are familiar with all the appliance's operating and safety characteristics.

**!** Connection of the wiring must be performed by a specialist technician.

- The manufacturer cannot be held responsible for any damage resulting from incorrect or inadequate installation.
- The minimum safety distance between the cooker hob and the extractor hood is: 600mm for electrical hob and 600mm for gas hob.
- If the gas hob installation instructions specify a distance greater than that indicated above, this must be taken into account.
- Check that the mains voltage corresponds to that indicated on the rating plate fixed to the inside of the hood.
- The cut-out devices must be installed in the fixed system ac-

according to the wiring system regulations.

- For Class I appliances, check that the domestic power supply has a suitable earthing connection.
- Connect the hood to the flue with a pipe with a minimum diameter of 150 mm. The fume path must be as short as possible.
- All the regulations regarding air discharge must be complied with.
- Do not connect the extractor hood to exhaust ducts carrying combustion fumes (boilers, fireplaces, etc.).
- If the extractor is used in conjunction with non-electrical appliances (e.g. gas burning appliances), a sufficient degree of ventilation must be guaranteed in the room in order to prevent the backflow of exhaust gas. When the cooker hood is used in conjunction with appliances supplied with energy other than electricity, the negative pressure in the room must not exceed 4 Pa mbar to prevent fumes being drawn back into the room by the cooker hood.
- The air must not be discharged into a flue that is used for exhausting fumes from appliances burning gas or other fuels.
- The power cord, if damaged, must be replaced by the manufacturer or by a service technician.
- Connect the plug to a socket complying with current regulations, located in an accessible place.
- Regarding the technical and safety measures to be adopted for fume discharging it is important to strictly follow the regulations provided by the local authorities.

 **WARNING:** Before installing the hood, remove the protective films.

- Use only screws and small parts of a type suitable for the hood.

 **WARNING:** failure to install the screws or fixing devices in accordance with these instructions may result in electrical hazards.

- Connect the hood to the power supply by means of a bipolar switch with a distance between the contacts of at least 3 mm.
- Do not look directly at the light through optical devices (binoculars, magnifying glasses...).
- Do not flambé under the hood; risk of fire.
- This appliance can be used by children aged from 8 years and above and by persons with reduced physical, sensory or mental capabilities or lacking in experience and knowledge if they have been given supervision or instruction concerning use of the appliance in a safe way and if they understand the hazards involved. Children must not play with the appliance. Cleaning and maintenance by the user must not be performed by children, unless they are supervised.
- Children should be supervised to ensure that they do not play with the appliance.
- The appliance is not to be used by persons (including children) with reduced physical, sensory or mental capabilities, or lacking in experience and knowledge, unless they have been given supervision or instruction.

 The accessible parts may become hot when used with cooking appliances

- Clean and/or replace the filters after the time specified (fire hazard).
- There must be adequate ventilation of the room when the hood is used at the same time as appliances burning gas or other fuels (not applicable to appliances that only discharge the air back into the room).
- Kitchen hoods and other cooking fume extractors can affect

the safe operation of appliances which burn gas or other fuels (including those in other rooms) due to the backflow of combustion gases. These gases can cause carbon monoxide poisoning. After installing a kitchen extractor hood or any other cooking fume extractor, make sure that the gas appliances are tested by a certified technician to guarantee that there is no backflow of combustion gases.

-  "In case of replacement with halogen lamp use only self-shielded tungsten halogen lamps or self-shielded metal halide lamps."

## General information

### Use

- Switch off or unplug the appliance from the mains supply before carrying out any maintenance work.
- The top of the hood must not be used as a shelf.
- The extractor hood has been designed exclusively to eliminate cooking smells in domestic use.
- Never use the extractor hood for purposes other than those for which it was designed.
- Never leave high flames under the extractor hood when it is on.
- Adjust the flame intensity to direct it onto the bottom of the pan only, making sure that it does not engulf the sides.
- Deep fat fryers must be continuously monitored during use: overheated oil can burst into flames.

### Installation method

The hood has been designed for installation and use in the "suction version" or in the "air recirculation version".



**Extraction version (see symbol in the installation instructions)**

Cooking steam is suctioned and channelled outside the house through a discharge duct (not supplied), fitted to the hood steam outlet. Make sure that the outlet duct is properly installed at the air outlet, using a suitable connection system.



**Air recirculation version (see symbol in the installation instructions)**

The air is filtered through one or more carbon filters, and then resent into the room.

**Important:** Ensure appropriate air circulation around the hood.

**Important:** If the hood is supplied without carbon filters and installed on recirculation mode, these must be fitted before the hood can be used. The filters are commercially available.



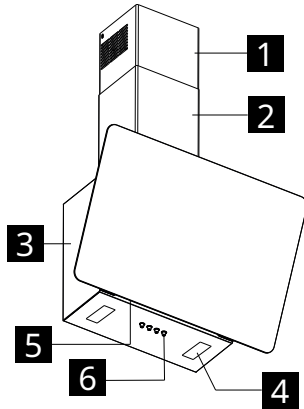

The hood should be installed away from particularly dirty areas, windows, doors and heat sources. Wall mounting accessories are not included as they vary depending on the wall material. Use fixing systems suitable for the walls of your home and for the weight of the appliance. For further details, contact a specialist dealer. Keep this booklet for future consultation.

**Product description**



- 1** Upper chimney
- 2** Lower chimney
- 3** Hood body
- 4** Lighting
- 5** Grease filter
- 6** Control panel

**Control panel**

   	
<p><b>A</b>                      <b>B</b>                      <b>C</b>                      <b>D</b></p>	
<b>A</b> Light	Turns the lighting system on and off.
<b>B</b> Speed	Runs the motor at Speed One. Turns off the motor.
<b>C</b> Speed	Runs the motor at Speed Two. Button B must be selected.
<b>D</b> Speed	Runs the motor at Speed Three. Button B must be selected.

## General tips

- Operate the hood at minimum speed at the start of cooking and keep it running for a few minutes after cooking is finished.
- Only increase the speed in the presence of large quantities of smoke and steam and only use the booster speed(s) in extreme situations.
- Replace the filter or carbon filters when necessary to maintain good odour reduction efficiency.
- Clean the grease filter or filters when necessary to maintain good grease absorption efficiency.
- Use the maximum diameter of the ducting indicated in this manual to optimise efficiency and to minimise noise.

## Cleaning and maintenance



Switch off or unplug the appliance from the mains supply before carrying out any maintenance work.

**IMPORTANT:** Clean the hood using a damp cloth and a neutral liquid detergent.

### Long-life carbon filter

The odour filter can be washed and regenerated every 3-4 months (or more frequently if the hood is subject to intensive use), up to a maximum of 8 regeneration cycles (in case of particularly intensive use it is recommended that you do not exceed 5 cycles).

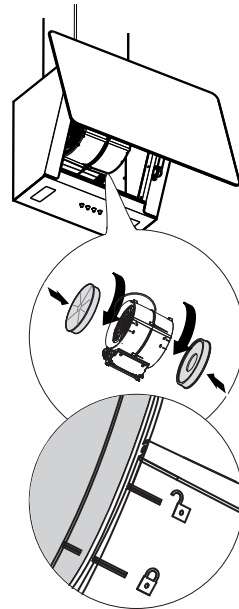

### Regeneration procedure

- Wash in the dishwasher at a MAX temperature of 70° or hand wash in hot water without using abrasive sponges (do not use detergents!).
- Dry in the oven at a MAX temperature of 70 °C for 2 hours (it is advisable to carefully read the user manual and the assembly instructions of the oven you own).

**Grease filters**

Keep cleaning or replacing the filters continuously according to below time intervals, to maintain good performance of the hood and to prevent a potential fire hazard, caused by excessive grease build-up. The grease filters must be cleaned after every 2 months of operation or more frequently in the case of very intense use and are dishwasher safe.

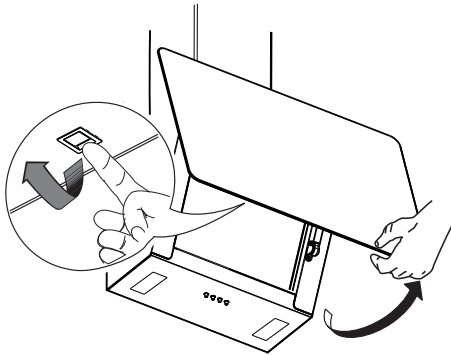

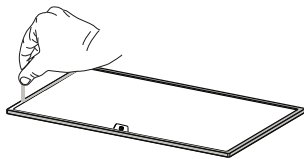

The grease filter protection must be disposed of as PE-LD 04 material, in accordance with local regulations.

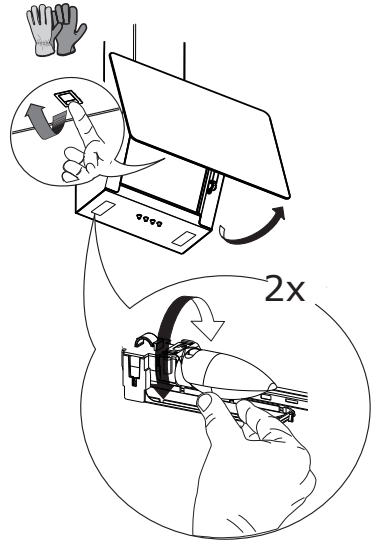

**Light replacement**

Unscrew the light bulbs using safety gloves and replace them with new light bulbs with the same characteristics (4W power, E14 connection).



Light	Absorption (W)	Connection	Voltage (V)	Dimensions (mm)	ILCOS code
	4	E14	220-240	107x37	DRBB/F-4-220-240-E14-35/100

**What to do if...**

If there is a fault, first try to find a solution yourself. If you are unable to resolve the problem yourself, contact an authorised service centre.

**i** In the event of improper use of the appliance or installation carried out without respecting the assembly instructions, it may be necessary to pay for the visit of an Authorised Service Centre technician, even during the warranty period.

PROBLEM	POSSIBLE CAUSE	SOLUTION
The device is not stable.	The appliance has not been installed correctly.	Follow the installation instructions supplied with the appliance.
The appliance is not level.	The appliance has not been installed correctly.	Follow the installation instructions supplied with the appliance.
The performance in terms of grease capture is not satisfactory.	Presence of oil and grease on the metal filters or on the carbon filters.	Observe the cleaning frequency of the filters as described in the user manual.
The appliance does not work.	The device has not been connected correctly.	Check that the mains cable is connected to the motor unit or that the plug is connected to the socket.
The light doesn't work.	The LED is broken.	For replacement, contact an Authorised Service Centre.
The hood is noisier than the customer's expectations.	The diameter of the air vent in the wall is too small and causes the pressure to drop and the motor speed to increase.	Follow the installation instructions supplied with the appliance.
	The product is installed in recirculation mode.	The product in recirculation mode (and with the carbon filter fitted) is noisier than a product in suction mode.
	The ventilation duct has more than one bend.	If the fume evacuation system of the building has multiple bends or covers a long distance, the product may be noisier.

**Before contacting the Authorised Service Centre:**

Turn the power back on to check whether the problem has disappeared. If this is not the case, turn it off and repeat the operation after one hour. If the appliance still does not work correctly after carrying out the checks listed in the troubleshooting guide and turning the appliance back on, contact the Authorised Service Centre clearly explaining the problem and specifying:

- the type of fault;
- the model;
- the type and serial number of the appliance (indicated on the data plate).

**Technical data**

		Unit	Value
Type of product			Wall-mounted hood
Dimensions	Width	mm	545
	Depth	mm	359
	Min./max. output height	mm	765 / 1015
	Min./max. recirculation height	mm	865 / 1115
Max air flow* - Output		m3/h	450
Noise max* - Exhaust		dBA	60
Airflow max* - Recirculating		m3/h	370
Noise max* - Recirculating		dBA	73
Total power		W	283
Information on the light	Type		LED light
	Number and power		2 x 4W
	Connection		E14
Minimum installation height - gas hob		mm	600
Minimum installation height - electric hob		mm	600
Net weight		Kg	7,75
* Maximum speed (without booster setting)			

This appliance has been designed, manufactured and sold in compliance with the EEC directives **CE**.

The technical data are shown on the plate applied inside the appliance.

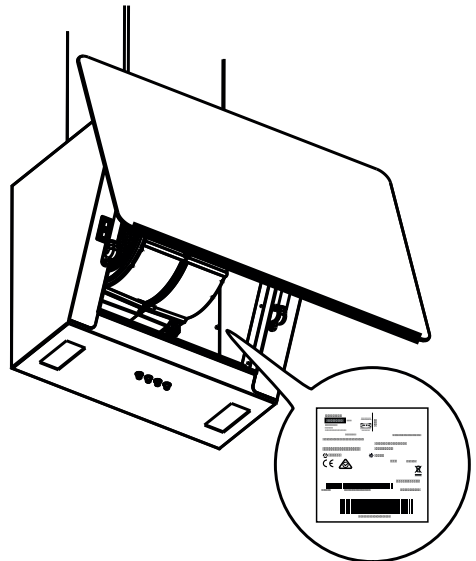

**Environmental aspects**

**Maintenance**



The symbol  on the product or on its packaging indicates that this product may not be treated as household waste. Instead it shall be handed over to the applicable collection point for the recycling of electrical and electronic equipment. By ensuring this product is disposed of correctly, you will help prevent potential negative consequences for the environment and human health, which

could otherwise be caused by inappropriate waste handling of this product. For more detailed information about recycling of this product, please contact your local city office, your household waste disposal service or the shop where you purchased the product.

**Packaging materials**



The materials with the symbol  are recyclable. Dispose the packaging in suitable collection containers to recycle it.

**IKEA guarantee**

**How long is the IKEA guarantee valid?**

This guarantee is valid for five years from the original date of purchase of your appliance at IKEA Pty Ltd, ABN 84 006 270 757, and IKEA NEW ZEALAND LIMITED, NZBN is 9429047515468.

The original sales receipt, is required as proof of purchase. If service work is carried out under guarantee, this will not extend the guarantee period for the appliance.

**Who will execute the service?**

IKEA service provider will provide the service through its own service operations or authorized service partner network. Contact IKEA for further information.

If you encounter any trouble with the appliance and wish to register a service call or make a claim, please refer to [www.ikea.com](http://www.ikea.com) for your local store after sales customer service center phone number, online email and opening times.

The principal address and contact details in Australia are:

IKEA Pty Ltd
IKEA Pty Ltd IKEA Service Office L1 Clock Tower, 630 Princes Highway Tempe, NSW 2044
Contact - IKEA Customer Service at <a href="http://www.IKEA.com">www.IKEA.com</a>

The principal address and contact details in New Zealand are:

IKEA New Zealand Limited
IKEA New Zealand Limited IKEA Service Office L1 Clock Tower, 630 Princes Highway Tempe, NSW 2044
Contact - IKEA Customer Service at <a href="http://www.IKEA.com">www.IKEA.com</a>

**What does this guarantee cover?**

The guarantee covers faults of the appliance, which have been caused by faulty construction or material faults from the date of purchase from IKEA. This guarantee applies to domestic use only. The products have been designed and tested for domestic purposes only and this guarantee does not cover damage arising from use of the Product in a commercial environment.

The exceptions are specified under the headline "What is not covered under this

guarantee?" Within the guarantee period, the costs to remedy the fault e.g. repairs, parts, labour and travel will be covered, provided that the appliance is accessible for repair without special expenditure. Replaced parts become the property of IKEA.

The guarantee exists only if the appliance complies and is installed in accordance with:

- The technical specifications.
- The Assembly Instructions and user manual Safety Information.

IKEA's guarantee is subject to Australian Consumer Law - see Schedule 2 to Competition and Consumer Act, 2010 and New Zealand Consumer Guarantees Act 1993. This guarantee is in addition to (and does not exclude, restrict or modify in any way) any non-excludable statutory warranties in Australia.

#### **What will IKEA do to correct the problem?**

IKEA appointed service provider will examine the product and decide, at its sole discretion, if it is covered under this guarantee.

They will notify you as to whether your claim is covered under this guarantee. If your claim is approved, the IKEA service provider or its authorized service partner, will then, at its sole discretion, either repair the defective product or replace it with the same or a comparable product.

#### **What is not covered under this guarantee?**

Normal wear and tear.

- Deliberate or negligent damage, damage caused by failure to observe operating instructions, incorrect installation or by connection to the wrong voltage, damage caused by chemical or electro-chemical reaction, rust, corrosion or water damage including but not limited to damage caused by excessive lime in the water supply, damage caused by abnormal environmental conditions.
- Consumable parts including batteries and lamps.
- Non-functional and decorative parts which do not affect normal use of the appliance,

including any scratches and possible colour differences.

- Accidental damage caused by foreign objects including insect or vermin infestation or substances and cleaning or unblocking of filters, drainage systems or soap drawers.
- Damage to the following parts: ceramic glass, accessories, crockery and cutlery baskets, feed and drainage pipes, seals, lamps and lamp covers, screens, knobs, casings and parts of casings. Unless such damages can be proved to have been caused by production faults.
- Cases where no fault could be found during a technician's visit.
- Repairs not carried out by our appointed service providers and/or an authorized service contractual partner or where non-original parts have been used.
- Repairs caused by installation which is faulty or not according to specification.
- The use of the appliance in a non-domestic environment i.e. professional use.
- Transportation damages. If a customer transports the product to their home or other address, IKEA is not liable for any damage that may occur during transport. However, if IKEA delivers the product to the customer's delivery address, then damage to the product that occurs during this delivery will be covered by this guarantee.
- Cost for carrying out the initial installation of the IKEA appliance. However, if an IKEA service provider or its authorized service partner repairs or replaces the appliance under the terms of this guarantee, the service provider or its authorized service partner will reinstall the repaired appliance or install the replacement, if necessary.
- The appliance's serial number or warranty seal has been removed or defaced.

#### **How country law applies**

Our goods come with guarantees that Our goods come with guarantees that cannot be excluded under the Australian Consumer Law (ACL) and New Zealand Consumer Guarantees Act 1993. You are entitled to a replacement or refund for a major failure and

compensation for any other reasonably foreseeable loss or damage.

You are also entitled to have the goods repaired or replaced if the goods fail to be of acceptable quality and the failure does not amount to a major failure.

This guarantee is not intended in any way to limit or exclude such rights and remedies that you may have under law.

You can find out more information in the following web pages:

- The Australian Consumer Law on the ACCC website: [www.accc.gov.au](http://www.accc.gov.au).
- The Commerce Commission website : <https://comcom.govt.nz/>
- Consumer Protection website: <https://www.consumerprotection.govt.nz/general-help/consumer-laws/consumer-guarantees-act>

### Area of validity

This IKEA guarantee applies only to products purchased and installed in AUSTRALIA and New Zealand.

### What you must do to make a claim under the guarantee:

To make a claim under the guarantee contact IKEA after sales customer service center at the above address or [www.ikea.com](http://www.ikea.com) for your local store customer service phone number, online email and opening times. Please describe the problem that you are facing with the appliance in detail along with your product article number (8 digit code) and date of purchase at the time of call registration.

### Please do not hesitate to contact the dedicated after sales customer service center for IKEA appliances to:

1. Make a service request under this guarantee;
2. Ask for clarification on installation of the IKEA appliance in the dedicated IKEA kitchen furniture.

3. Ask for clarification on user manual contents and specifications of the IKEA appliance.

To ensure that we provide you with the best assistance, please read carefully the Assembly Instructions and/or the User Manual section of this booklet before contacting us.

### How to reach us if you need our service



The IKEA after sales customer service centre will assist you on the phone with basic trouble shooting for your appliance at the time of service call request. Please refer to [www.ikea.com](http://www.ikea.com) and select your local store for local store phone numbers and opening times.

**i** Please describe the problem that you are facing with the appliance in detail along with your product article number ( 8 digit code ) and date of purchase at the time of call registration.

### **i** SAVE THE SALES RECEIPT!

Kindly keep all these details and original invoice of purchase handy during the service technician's visit to enable him to carry out the job. It is your proof of purchase and required for the guarantee to apply. Note that the receipt reports also the IKEA article name and number (8 digit code) for each of the appliances you have purchased.

Country name in local languages	Telephone number	Opening times
<b>Australia</b>	(02) 90100264	
<b>New Zealand</b>	+64 9 802 4864	







