

GB

FR

ES

LAGAN

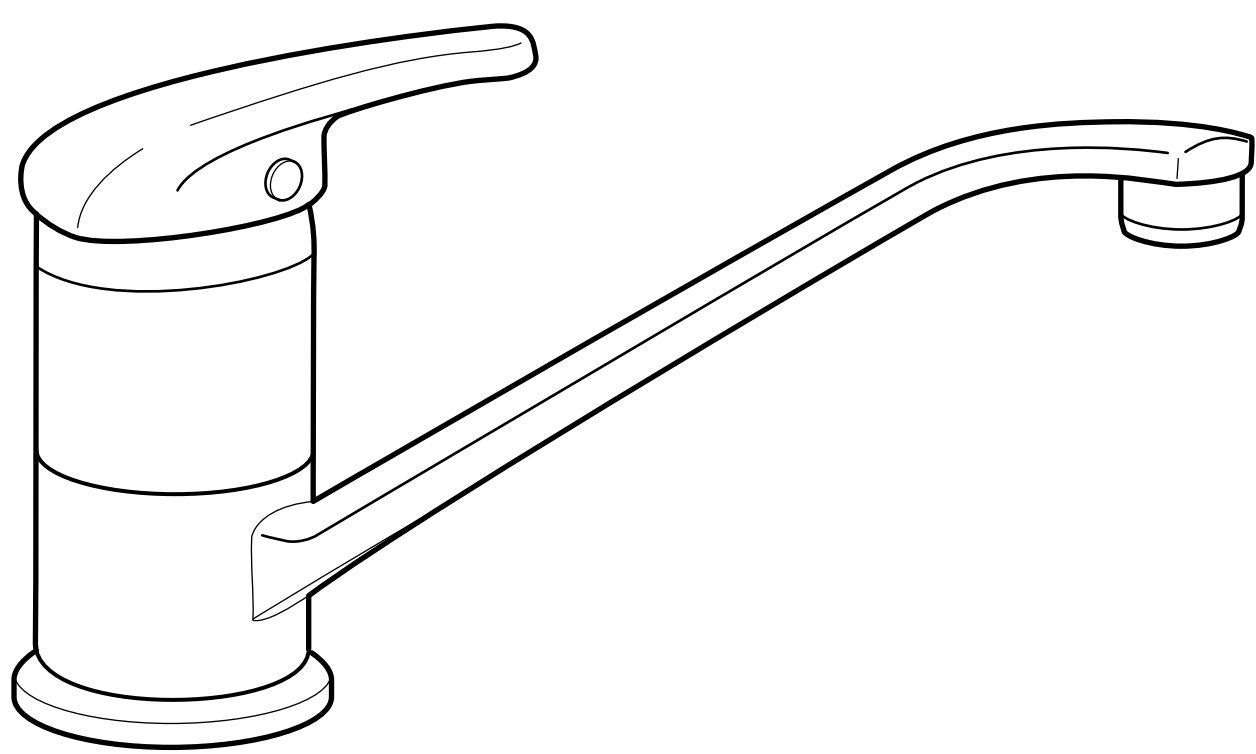

Design and Quality
IKEA of Sweden

**ENGLISH**

Installation must be performed in compliance with current local construction and plumbing regulations. If in doubt, contact a professional.

FRANÇAIS

L'installation doit être réalisée en conformité avec les normes actuelles relatives à la construction et à la plomberie. En cas de doute, contacter un professionnel.

ESPAÑOL

La instalación debe realizarse siguiendo las normativas actuales sobre construcción y fontanería. En caso de duda, ponte en contacto con un profesional.

**ENGLISH**

Switch off main shut-off valve before changing mixer tap.

FRANÇAIS

Fermer le robinet central d'eau avant de changer le mitigeur.

ESPAÑOL

Cierra la llave de paso general antes de cambiar el grifo.

**ENGLISH**

Check at regular intervals to make sure that the installation is not leaking.

FRANÇAIS

Vérifier à intervalles réguliers que l'installation ne fuit pas.

ESPAÑOL

Comprobar a intervalos regulares que la instalación no gotee.

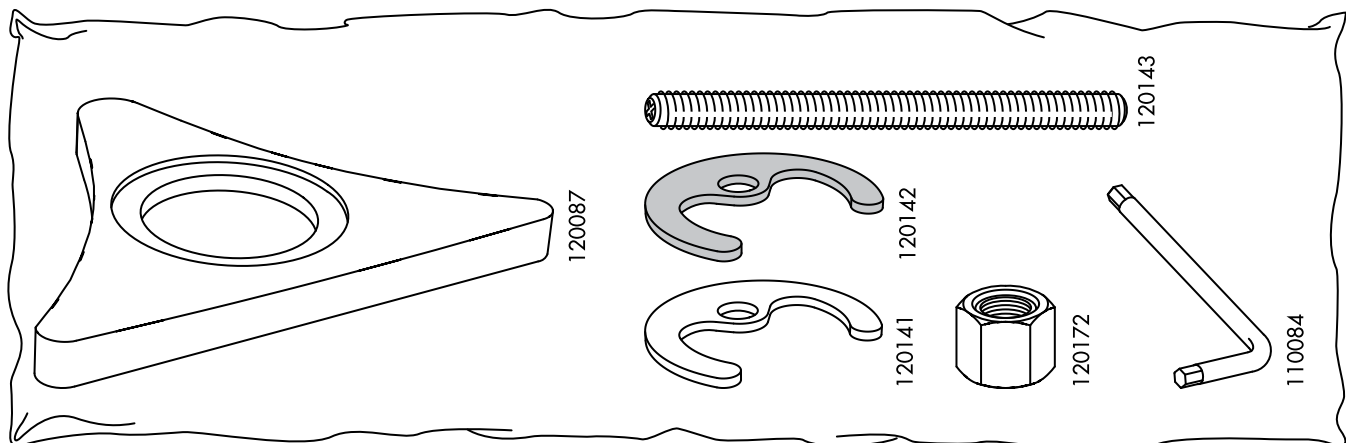
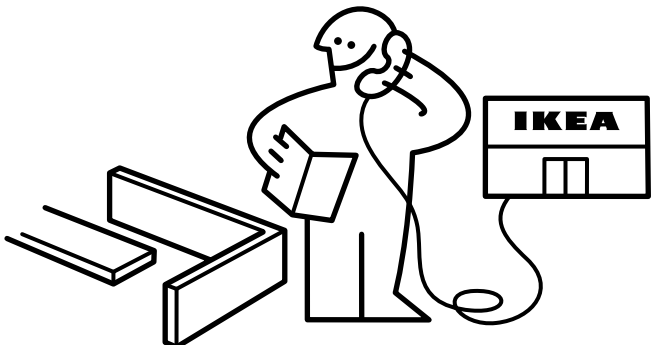
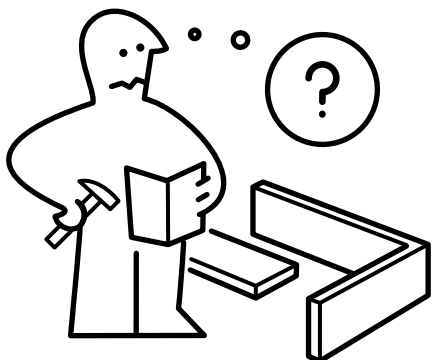
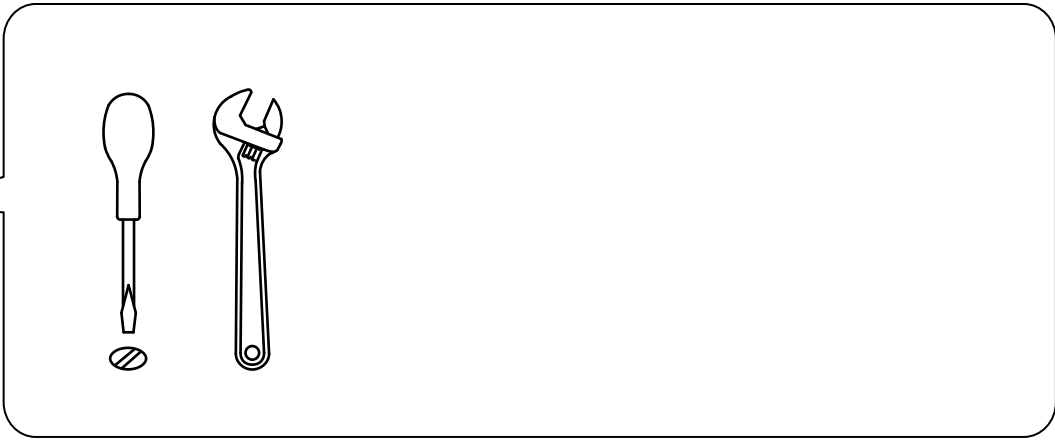
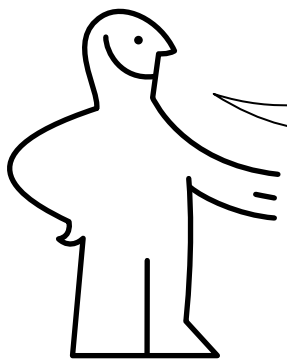

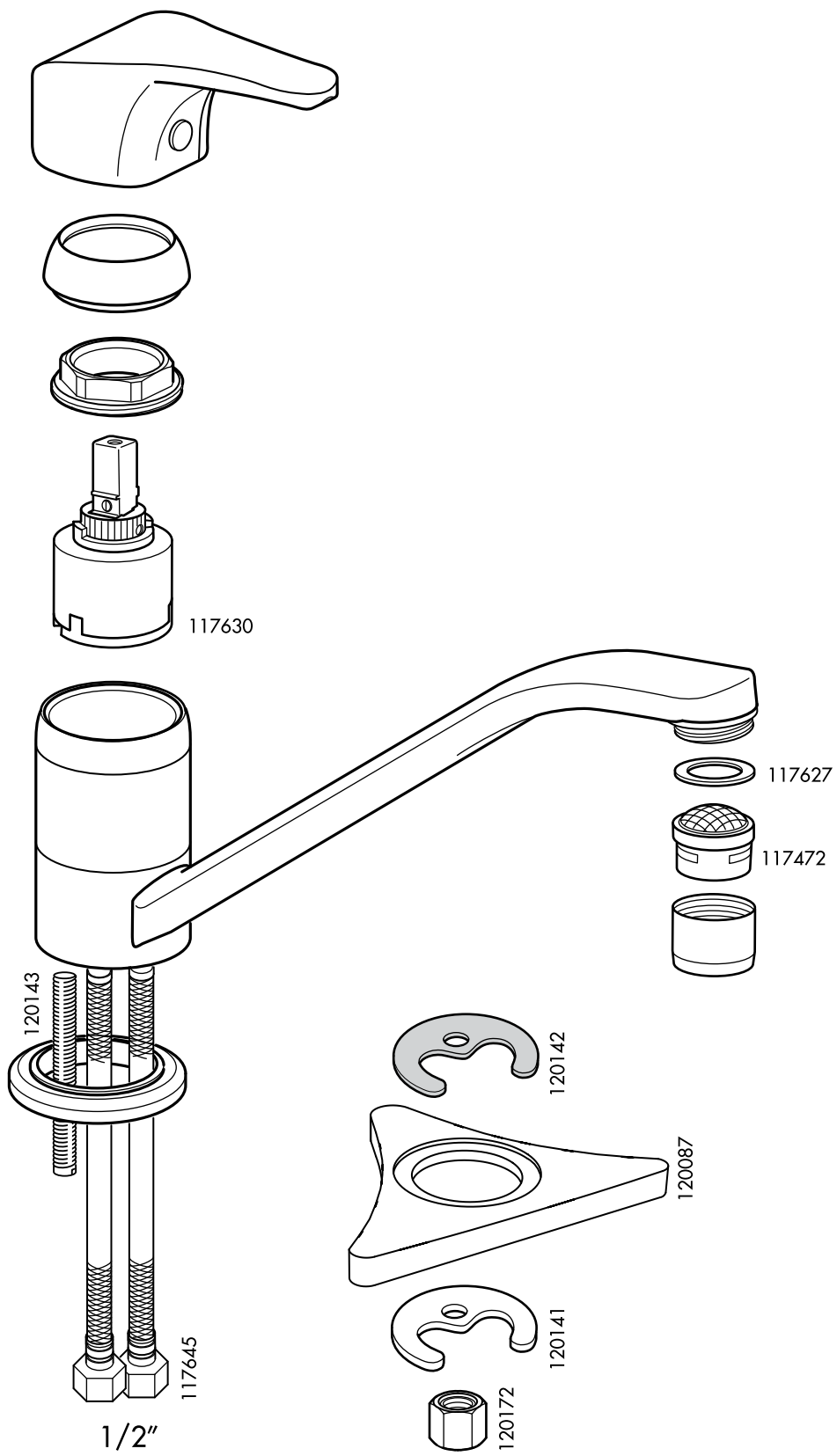

1

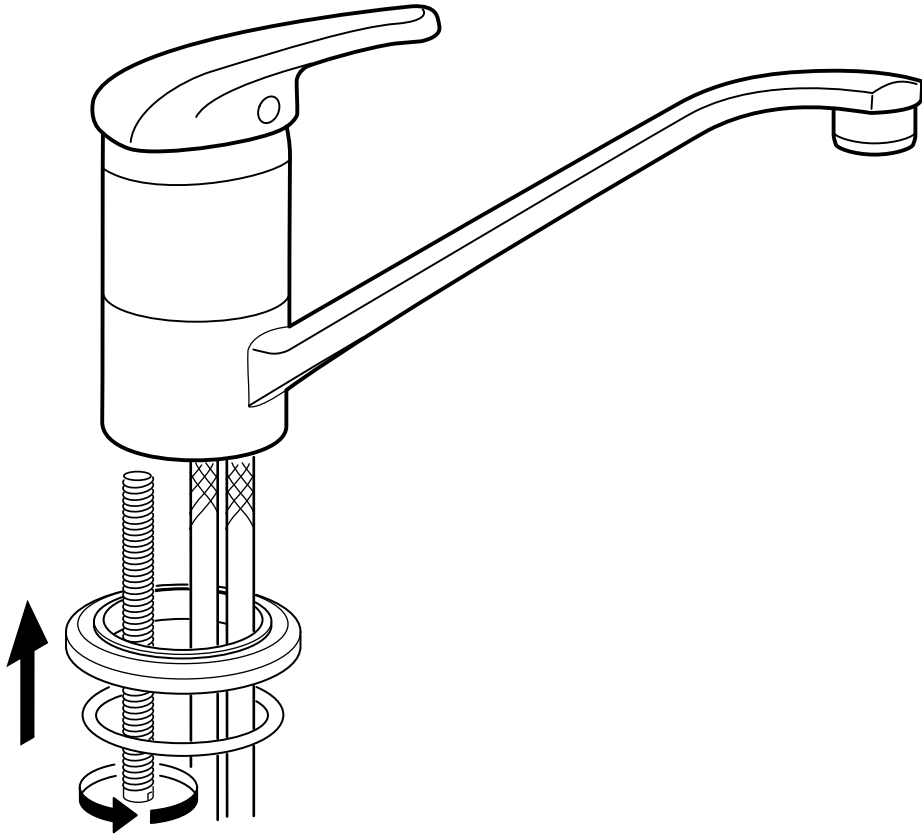

2

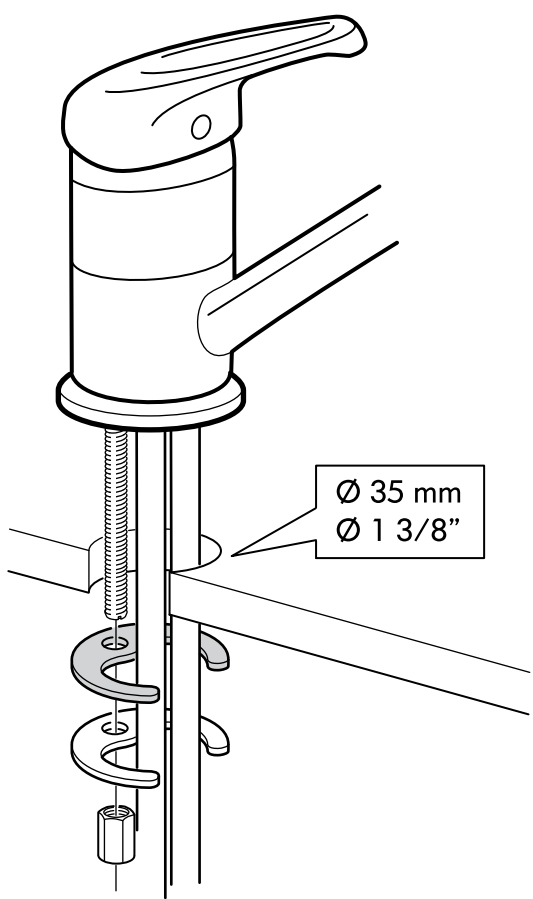
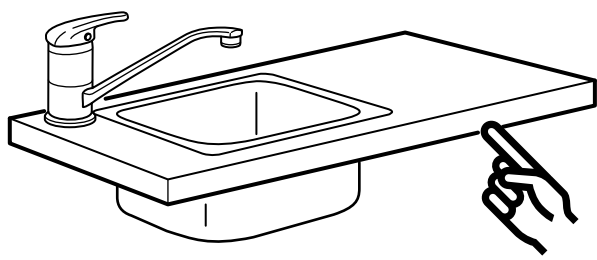

2

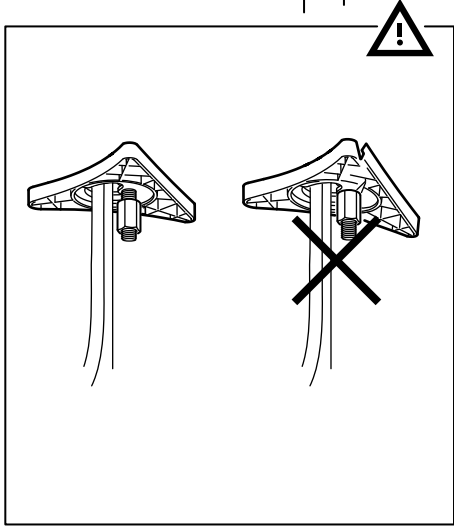
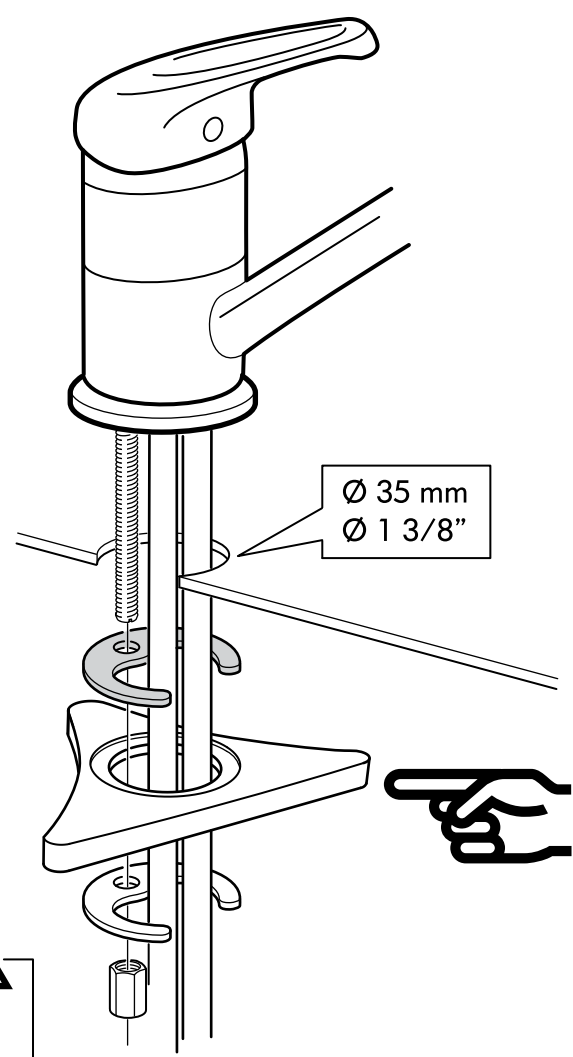
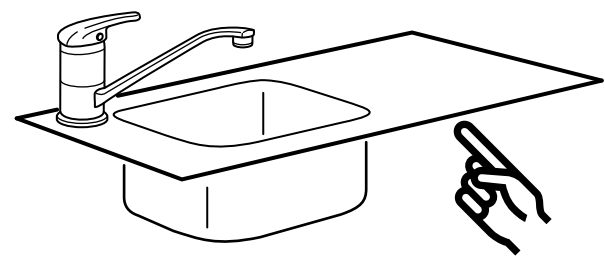

3

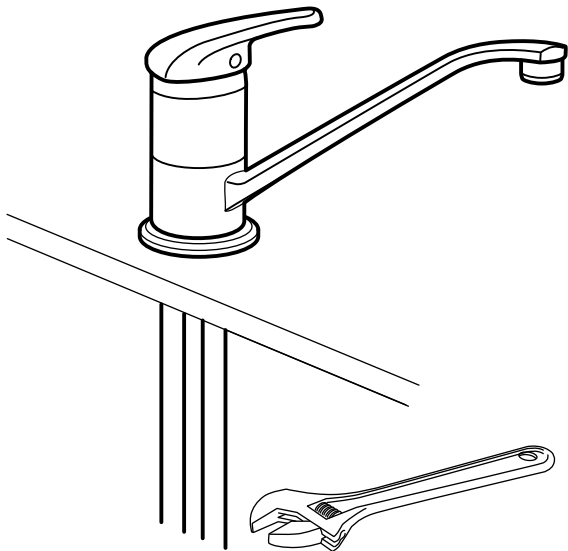

ENGLISH

IMPORTANT! Do not tighten too hard: this can damage hoses/pipes and washers.

FRANÇAIS

ATTENTION ! Ne pas serrer trop fort : cela pourrait abîmer les flexibles/tuyaux et les joints.

ESPAÑOL

¡ATENCIÓN! No aprietes demasiado, ya que se pueden dañar las tuberías/conductos y las juntas.

ENGLISH

Before use: unscrew the filter and allow the water to run freely for 5 minutes. Then screw the filter back in place.

FRANÇAIS

Avant utilisation : dévisser le filtre et laisser l'eau couler pendant 5 minutes. Puis revisser le filtre.

ESPAÑOL

Antes de usar: desenrosca el filtro y deja que corra el agua durante 5 minutos. Luego, vuelve a enroscar el filtro.

