

BLIXT

ENGLISH
FRANÇAIS
ESPAÑOL

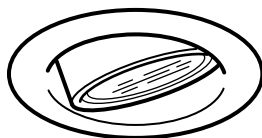

Design and Quality
IKEA of Sweden

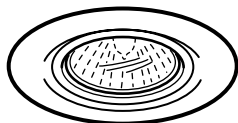

ENGLISH

INSTALLATION INSTRUCTIONS

CAUTION: Before starting, turn off power at main circuit panel.

THIS PRODUCT MUST BE INSTALLED IN ACCORDANCE WITH THE APPLICABLE INSTALLATION CODE BY A PERSON FAMILIAR WITH THE CONSTRUCTION AND OPERATION OF THE PRODUCT AND THE HAZARDS INVOLVED.

The clearance space above the lighting fittings shall be minimum 13 mm (1/2"), and the lateral distance from surrounding building or insulating material shall be minimum 300 mm (11 3/4").

FRANÇAIS

INSTRUCTIONS D'INSTALLATION

ATTENTION: Couper l'alimentation au panneau principal avant de procéder à l'installation.

CE PRODUIT DOIT ETRE INSTALLE CONFORMEMENT A LA REGLEMENTATION EN VIGUEUR PAR UNE PERSONNE QUI CONNAIT LE PRODUIT, SA CONCEPTION ET SON FONCTIONNEMENT AINSI QUE LES RISQUES LIES A SON UTILISATION.

Prévoir un espace libre de tout matériau de construction ou d'isolation de 300 mm de chaque côté du luminaire et un espace libre de 13 mm minimum au dessus du celui-ci.

ESPAÑOL

INSTRUCCIONES DE INSTALACIÓN

¡ADVERTENCIA! Cortar el suministro de luz en el cajetín general antes de comenzar los trabajos de instalación. **ESTE PRODUCTO SE DEBE INSTALAR SIGUIENDO LAS INSTRUCCIONES DE ERICSSON, EL FABRICANTE, QUE CONOCE EL PRODUCTO Y SU FUNCIONAMIENTO, ASÍ COMO EVENTUALES RIESGOS QUE PUDIERA ENTRAÑAR.**

El espacio libre encima de las bombillas debe ser como mínimo de 13 mm y la distancia a materiales de construcción y de aislamiento será como mínimo de 300 mm.

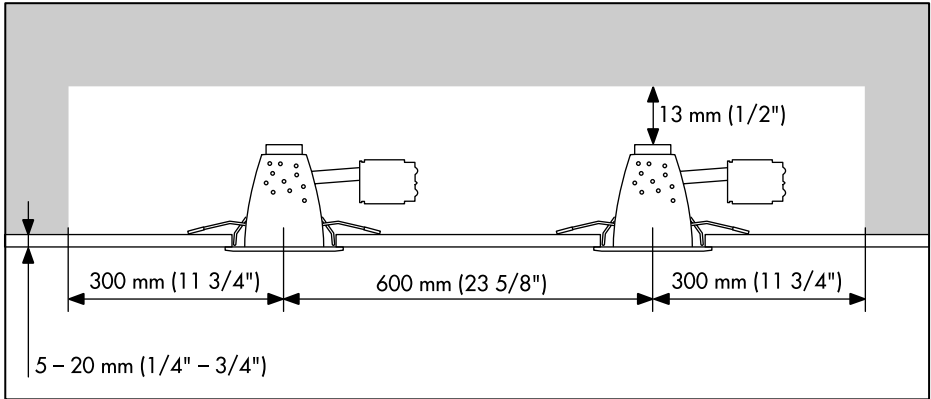

FRANÇAIS

Distance minimum entre l'ampoule et l'objet éclairé : 0,5 m .

ENGLISH

Minimum safe distance from illuminated object: 0.5 m.

ESPAÑOL

Distancia mínima al objeto a iluminar: 0,5 m.

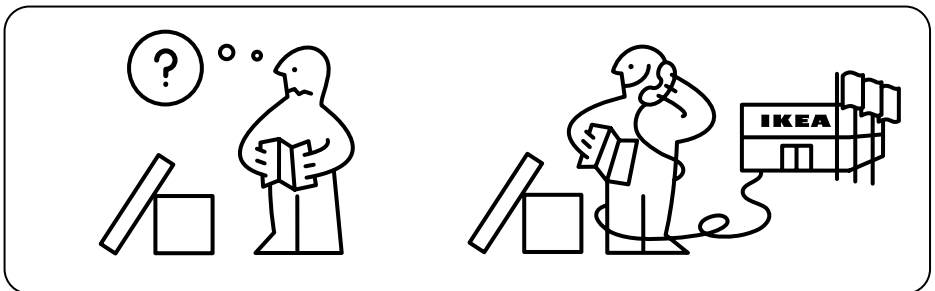
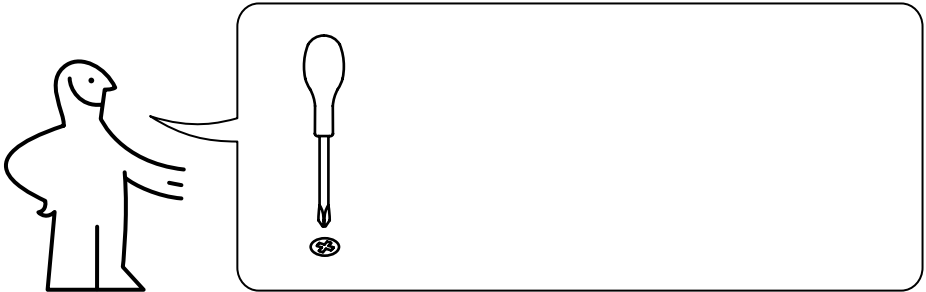



1x

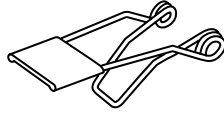

9x

1

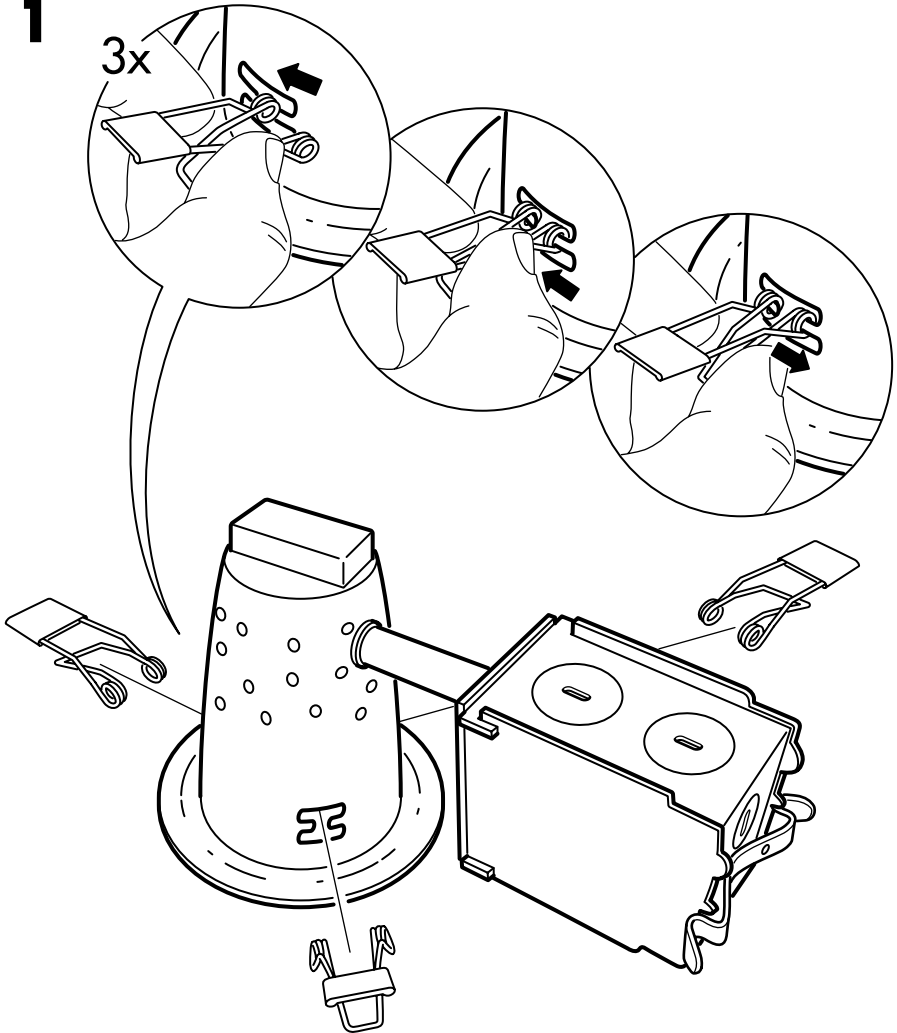

2

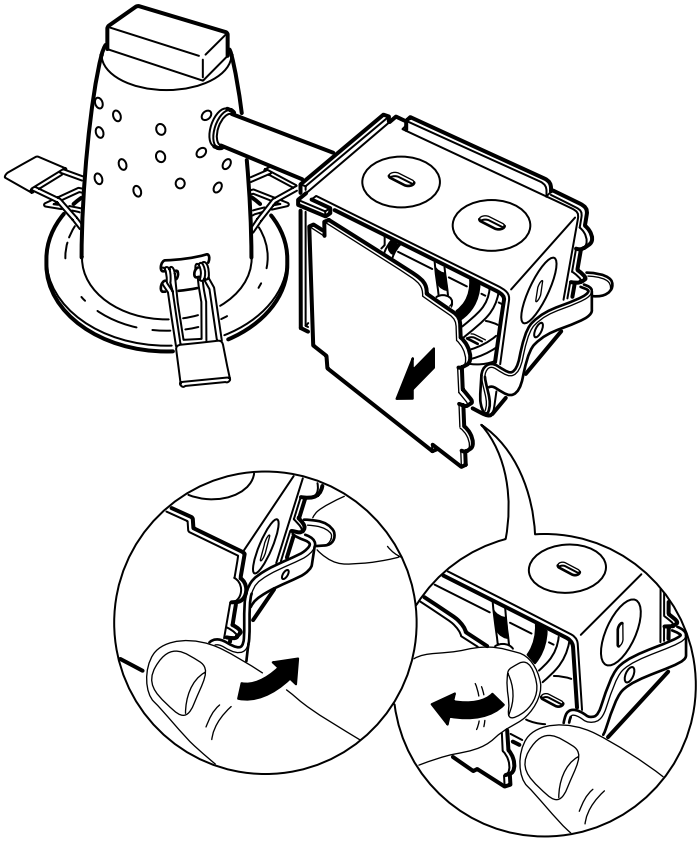

3

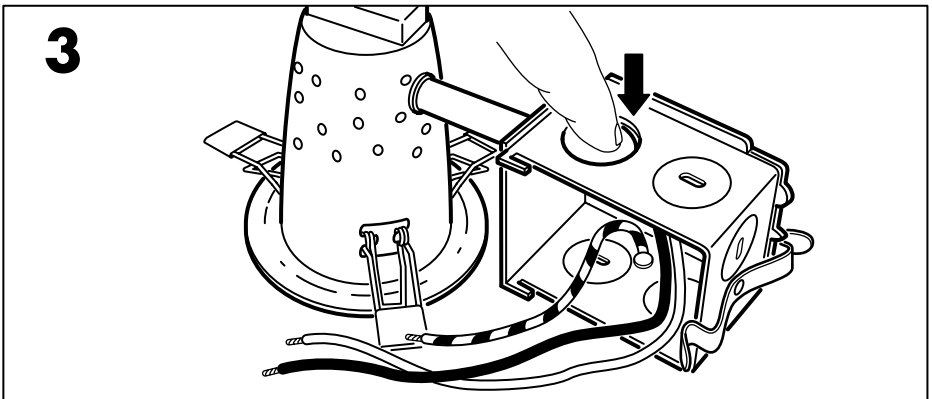

4

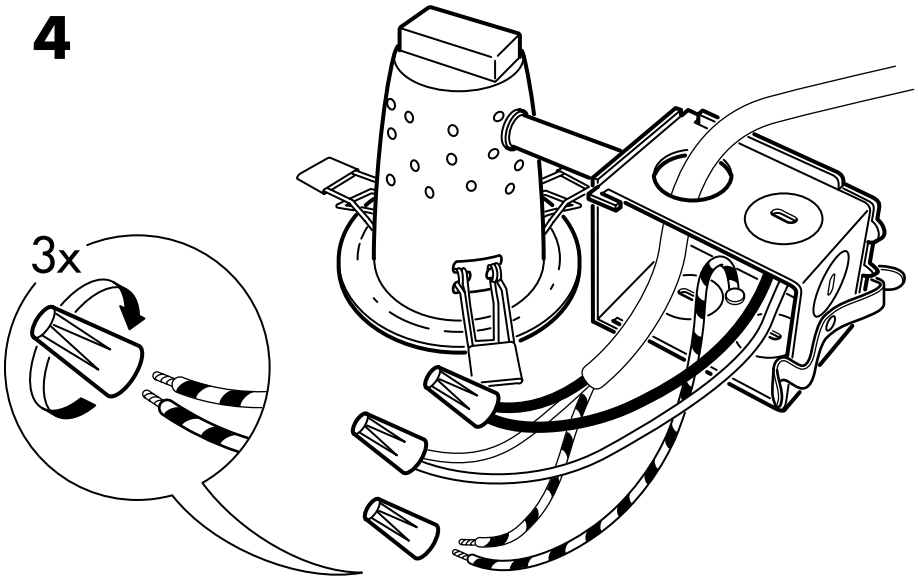

5

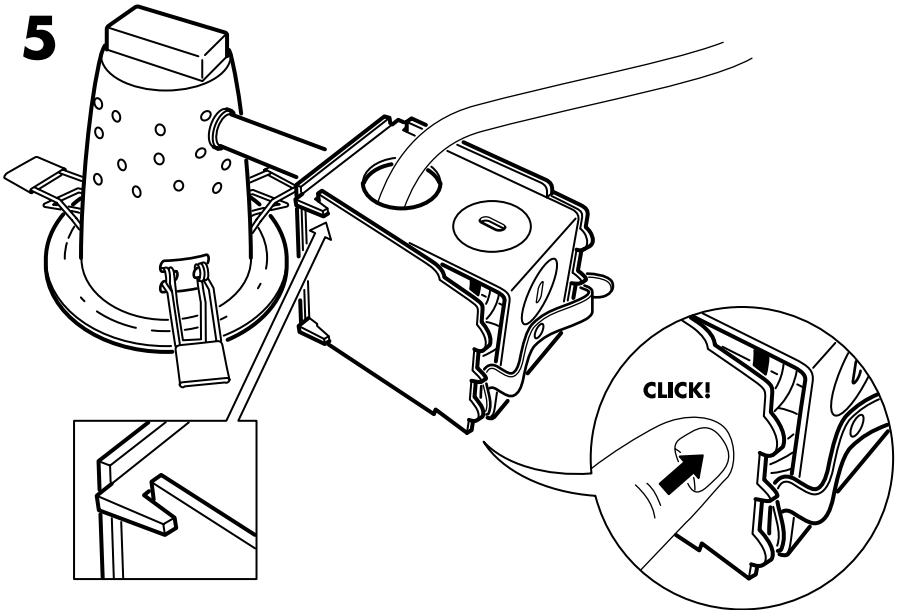

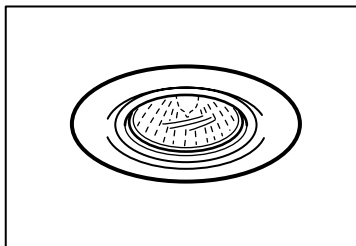
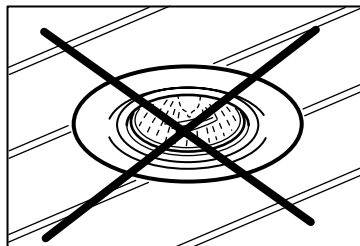

ENGLISH

CAUTION:

Only to be mounted in tight ceilings.
This does only concern usage in damp
locations.

ESPAÑOL

¡ATENCIÓN!

Sólo montar en techos sólidos.
Afecta al uso en zonas húmedas.

FRANÇAIS

MISE EN GARDE!

Doit être installé dans un plafond
étanche.
Concerne uniquement l'installation
dans un local humide.

6

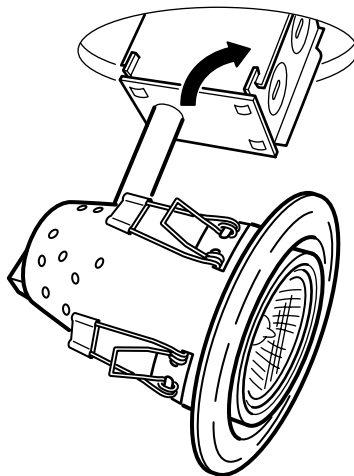
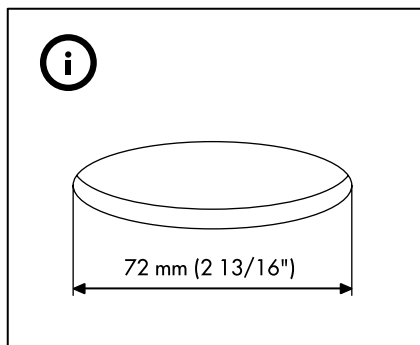

7

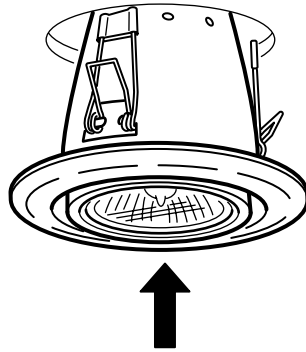

ENGLISH

WHEN REPLACING BULB - use an GU 10 class bulb with built-in protective glass guard.

FRANÇAIS

REPLACEMENT DE L'AMPOULE
- Utiliser une ampoule GU 10 avec verre de protection intégré.

ESPAÑOL

SUSTITUCIÓN DE BOMBILLA. Utiliza una bombilla tipo GU 10 con protector de bombilla incorporado.

